

N32H765EC

Datasheet

The N32H765EC series uses an ARM Cortex-M7 core, running at frequencies up to 600MHz, supporting double-precision floating-point operations and DSP instructions. It features (2/4MB) on-chip FLASH, integrates up to 1504KB of SRAM (including 1024KB TCM SRAM and 480KB SRAM) + 4KB Backup SRAM. It includes 3 12-bit 5Msps ADCs, 4 high-speed comparators, 6 12-bit DACs, and integrates multiple high-speed communication interfaces: U(S)ART, I2C, xSPI, SPI, USBFS Dual Role, USBHS Dual Role, CAN-FD, SDRAM, FEMC, SDMMC, 10/100/1000M Ethernet and EtherCAT. The series supports digital camera interface (DVP), TFT-LCD graphical interface, JPEG hardware codec and GPU. It features a built-in high-performance encryption algorithm hardware acceleration engine, supporting AES/TDES, SHA algorithms, TRNG true random number generator, and CRC8/16/32. It supports up to 126 GPIOs, and is available in UFBGA176+25 packages.

Key Features

- **Core CPU**
 - 32-bit ARM Cortex-M7 core, double-precision floating-point unit, supports DSP instructions and MPU
 - Built-in 32KB instruction Cache and 32KB data Cache with ECC
 - Maximum frequency 600MHz, 1284 DMIPS
- **Encrypted Memory**
 - On-chip Flash (2/4MB), supports encrypted storage and automatic program decryption during execution
 - 1504KB built-in SRAM, supports ECC verification
 - 1024KB TCM SRAM, configurable as D-TCM, I-TCM or SRAM
 - 480KB on-chip SRAM
 - 4KB Backup SRAM, supports ECC
- **Operating Modes**
 - Run mode
 - SLEEP mode: AXI enabled, AHB enabled
 - Stop0 mode: SRAM, TCM, RTC, LSE, IWDG enabled
 - Stop2 mode: Flash standby mode, SRAM, TCM, RTC, LSE, IWDG, Backup SRAM, backup registers enabled, I/O maintained
 - Standby mode: Backup SRAM, RTC, IWDG, LSE, backup registers enabled, SRAM, TCM disabled
 - VBAT mode: Backup SRAM, RTC, LSE, backup registers enabled
- **Clock**
 - 4MHz~48MHz external high-speed crystal
 - 4MHz~50MHz external clock input
 - 32.768KHz external low-speed crystal

- Built-in 3 high-speed PLLs
- Built-in MSI clock, supporting configuration of 31.25K/62.5K/125K/250K/500K/1M/2M/4M/8M/16MHz clocks
- Internal high-speed RC 64MHz
- Internal low-speed RC 32KHz
- **Reset**
 - Supports power-on/power-down/external pin reset
 - Supports watchdog reset and software system reset
 - Supports programmable voltage detection
- **High-Speed Communication Interfaces**
 - 7 USART interfaces/7 UART interfaces, supporting ISO7816, IrDA, LIN
 - 2 LPUART interfaces
 - 6 SPI interfaces, supporting master/slave modes, rates up to 50 MHz
 - 8 I2C interfaces, rates up to 3.4 MHz, configurable master/slave modes, dual address response in slave mode
 - 1 USBHS Dual Role interfaces
 - 1 USBFS Dual Role interfaces
 - 8 CAN-FD bus interfaces
 - 2 Ethernet MAC interface, supporting 10M/100M communication rates, supports IEEE 1588 time synchronization protocol
 - 1 EtherCAT Slave Controller (ESC) interface, with transmission rate up to 100Mbit/s, supporting 2 MII ports, 8 Fieldbus Memory Management Units (FMMU), 8 Synchronous Managers (SM), and 64-bit Distributed Clock (DC)
- **High-Performance Analog Interfaces**
 - 3 12-bit 5Msps ADCs, supporting 12-bit, 10-bit resolution, hardware oversampling up to 16-bit, supporting up to 55 external single-ended input channels, 5 internal single-ended input channels, supporting single-ended and differential modes
 - 4 high-speed analog comparators
 - 6 12-bit DACs, of which 2 1Msps DACs support output with or without Buffer separately, internal output only supports mode without Buffer; simultaneous internal and external output must enable Buffer; the other 2 DACs only support 1 output channel to the internal chip, with 15Msps sampling rate, supporting internal output without Buffer
 - 2 MCO outputs, configurable to output SYSCLK, HSE, MSI, LSE, LSI, HSI64 or PLL clock division
 - Supports 1 reference voltage VREFBUF (configurable as 1.5V/1.8V/2.048V/2.5V)
 - 1 temperature sensor
- **Audio Interfaces**
 - 4 I2S, supporting master/slave modes, audio sampling frequencies from 8KHz to 192KHz
 - 8 PDM digital microphone interfaces built into DSMU

- **Memory Extension Interfaces**
 - 1 FEMC (Flexible External Memory Controller) interface, bus rate 100 MHz, SRAM/PSRAM/Nor Flash supporting configurable 16/32-bit data width, NAND Flash supporting configurable 8/16-bit data width
 - 1 xSPI interface, supporting 1/2/4/8-bit data width, configurable master/slave, rates up to 133 MHz, can be used for external SRAM, PSRAM and Flash, supports XIP
 - 1 SDRAM interface, rates up to 133 MHz
 - 2 SDMMC interfaces, supporting SD/SDIO 3.0, eMMC 4.51 format, rates up to 104MHz
- **Image Processing Interfaces**
 - 2 digital camera interface (DVP), supporting 8/10/12/16bit, rates up to 110MHz
 - 1 TFT-LCD display interface, supporting up to 24-bit parallel digital RGB LCD, providing all signal interfaces, can directly connect to various LCD and TFT panels, resolution up to 1920x1080
 - Built-in 2.5D graphics processor, supporting image scaling, rotation, blending, anti-aliasing, texture mapping, etc.
 - Hardware JPEG codec
- **Maximum support for 126 GPIOs, low-speed GPIOs support 5V tolerance (under VDD = 3.3V ±10% conditions)**
- **Motor control Cordic accelerator, supporting trigonometric and hyperbolic function acceleration, supporting floating-point input and output**
- **Delta Sigma Module Unit (DSMU)**
- **Built-in filtering algorithm accelerator FMAC, supporting FIR, IIR filtering**
- **3 high-speed DMA controllers, each controller supporting 8 channels, 1 MDMA supporting 16 channels, freely configurable channel source and destination addresses**
- **RTC real-time clock, supporting leap year perpetual calendar, alarm events, periodic wake-up, supporting internal and external clock calibration**
- **Timer Counters**
 - 2 16-bit advanced timer counters, supporting input capture, complementary output, quadrature encoding input and other functions, highest control precision 3.3ns; each timer has 6 independent channels, of which 4 channels support 4 pairs of complementary PWM outputs
 - 4 advanced 16-bit timer counters, supporting input capture, complementary output, quadrature encoder input and other functions, with highest control precision of 3.3ns; each timer has 6 independent channels, of which 4 channels support 4 pairs of complementary PWM outputs
 - 10 16-bit general-purpose timers (GTIMA1-7/GTIMB1-3), each timer with 4 independent channels, supporting input capture, output compare, PWM generation
 - 4 32-bit basic timer counters (BTIM1~4)
 - 5 16-bit low-power timers (LPTIM1~5), can work in Stop2 mode
 - 1x 24-bit SysTick, 1x 14-bit window watchdog (WWDG), 1x 12-bit independent watchdog (IWDG)

- Programming Methods
 - Supports SWD/JTAG online debugging interface
 - Supports USB, UART Bootloader
- Security Features
 - FLASH has up to 4 encryption partitions, supporting storage encryption
 - Supports write protection (WRP), multiple levels of read protection (RDP) (L0/L1/L2)
 - Built-in password algorithm hardware acceleration engine, supporting AES/TDES, SHA, algorithms
 - TRNG true random number generator, CRC8/16/32 operations
 - Supports secure boot, encrypted program download, secure update, supports external high-speed and low-speed clock failure detection
 - Supports tamper detection
- **OTP supports 128-bit UCID**
- **Operating Conditions**
 - Operating voltage range:
 - 2.3V~3.6V
 - Chip junction temperature range: -40°C~125°C
- **Security Features**
 - USB IF
 - IEC61508 SIL2
- **Security Features**
 - TFBGA176+25(10mm x 10mm)
- **Ordering Models**

| Series | Models |
|--------------|------------------------------|
| N32H765Ix7EC | N32H765IKB7EC, N32H765IIB7EC |

1 Product Introduction

The N32H765IxB7EC series uses an ARM Cortex-M7 core, running at frequencies up to 600MHz, supporting double-precision floating-point operations and DSP instructions. It features (2/4MB) on-chip FLASH, integrates up to 1504KB of SRAM (including 1024KB TCM SRAM and 480KB SRAM) + 4KB Backup SRAM. It includes 3 12-bit 5Msps ADCs, 4 high-speed comparators, 4 12-bit DACs, and integrates multiple high-speed communication interfaces: U(S)ART, I2C, xSPI, SPI, USBFS Dual Role, CAN-FD, SDRAM, FEMC, SDMMC, and 10/100/1000M Ethernet.

The series supports digital camera interface (DVP), TFT-LCD graphical interface, JPEG hardware codec and GPU. It features a built-in high-performance encryption algorithm hardware acceleration engine, supporting AES/TDES, SHA, algorithms, TRNG true random number generator, and CRC8/16/32. It supports up to 126 GPIOs, and is available in UFBGA176+25 packages.

The N32H765IxB7EC series products can operate stably in a temperature range of -40°C to +105°C, with a supply voltage of 1.8V to 3.6V, offering multiple power consumption modes. Figure 1-1 shows the bus diagram of this series of products.

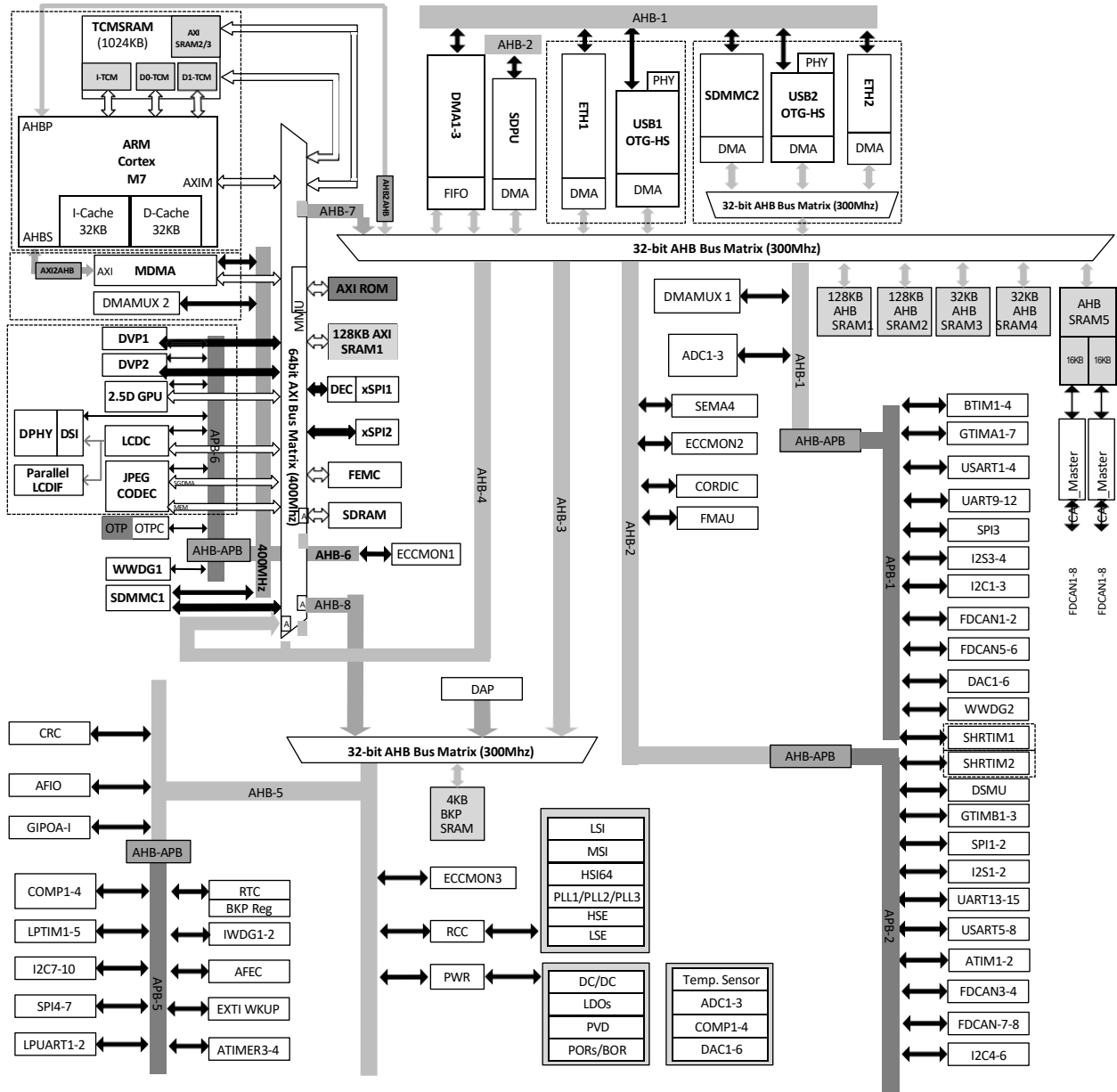
Figure 1-1 N32H765Ix87EC System Block Diagram

1.1 Naming Convention

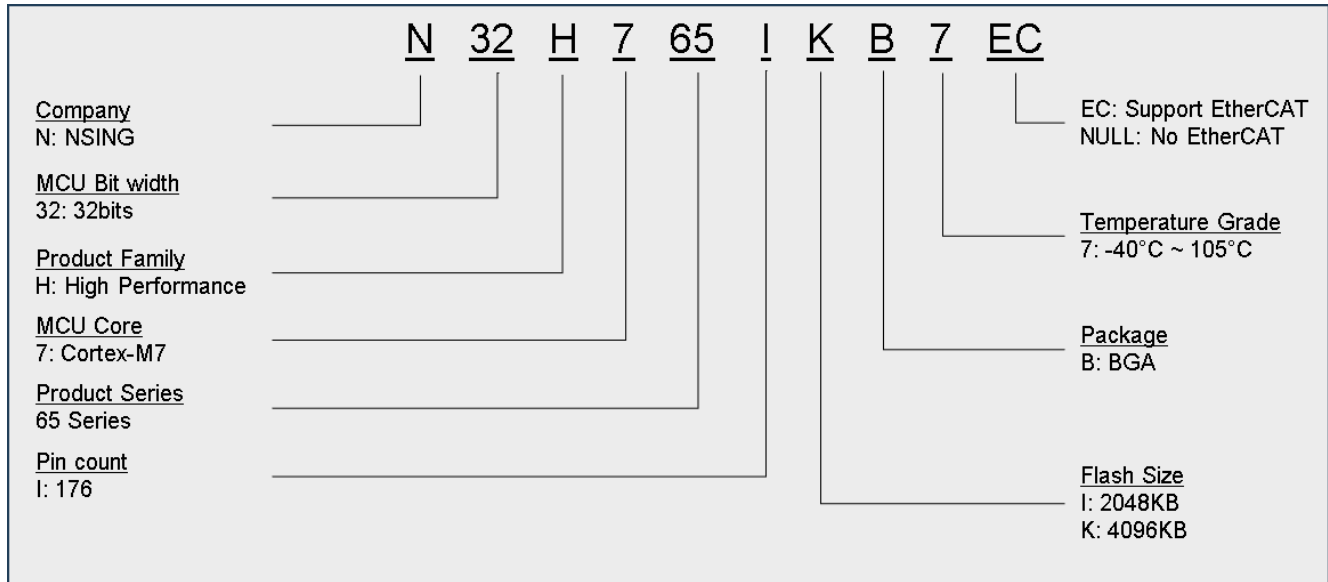

1.2 Product Model and Resources Configuration

Table 1-1 N32H765Ix7EC Series Resource Configuration

| Device Mode | | N32H765IKB7EC | N32H765IIB7EC |
|-------------------------|---------------------------------|---|---------------|
| Flash (KB) | | 4096 | 2048 |
| SRAM (KB) | TCM | 1024 | |
| | System RAM | 480 | |
| | Backup RAM | 4 | |
| Core | M7 | 600MHz | |
| Operating Voltage | | 2.3V~3.6V | |
| DCDC(step-down) | | Yes | |
| Coprocessor | Cordic | Yes | |
| | DSMU | Yes | |
| | FMAC | Yes | |
| Timers | SHRTIM | 2 | |
| | ADTIM | 4 | |
| | GPTIM | 10 | |
| | BSTIM | 4 | |
| | LPTIM | 5 | |
| | SysTick timer | 1 | |
| | WWDG | 1*14bit | |
| | IWDG | 1*12bit | |
| | RTC | Yes | |
| Communication Interface | SPI/I2S | 6/4 | |
| | I2C | 8 | |
| | USART | 7 | |
| | UART | 6 | |
| | LPUART | 2 | |
| | USBHS Dual Role | 1 | |
| | USBFS Dual Role | 1 | |
| | CAN FD | 8 | |
| | ESC | Yes | |
| | 10/100M ETH | 1 | |
| | 10/100/1000M ETH | 1 | |
| Expanded Storage | SDRAM | Yes | |
| | xSPI | 1 | |
| | FEMC | Yes | |
| | SDMMC | 2 | |
| Analog | 12bit ADC | 3 | |
| | 12bit DAC Number of channels | 2+4 ⁽¹⁾ 2 External channels | |
| | 比较器 | 4 | |
| | VREFBUF | Yes | |

| | | |
|----------------------------|------|--|
| Imaging | LCDC | Yes |
| | GPU | Yes |
| | JPEG | Yes |
| | DVP | 2 |
| GPIO | | 126 |
| DMA Number of channels | | 3 24Channel |
| MDMA Number of channels | | 1 16Channel |
| Algorithm Support | | DES/3DES, AES, SHA1/SHA224/SHA256, CRC8/16/CRC32 |
| Security Protection | | Read/write protection (RDP/WRP), storage encryption, secure boot |
| Package | | UFBGA176+25 |

Note: 4 DACs only support internal connection and cannot output to GPIO

2 Functional Overview

2.1 Processor Core

N32H762 series devices are based on the high-performance Arm® Cortex®-M7 32-bit RISC core. Operating frequency reaches up to 600 MHz. It supports floating-point unit (FPU), Arm® single-precision and double-precision operations and conversions (IEEE 754 compatible), includes a complete set of DSP instructions and memory protection unit (MPU) to enhance application security.

2.1.1 Arm® Cortex®-M7

Arm® Cortex®-M7 is a high-performance processor. It features a 6-stage superscalar pipeline with an FPU capable of both single-precision and double-precision operations. Instruction and data buses are extended to 64-bit width.

The processor supports the following interfaces:

- 64-bit AXI4 interface
- 32-bit AHB master interface
- 32-bit AHB slave interface
- 64-bit instruction TCM interface
- 2x32-bit data TCM interfaces

Other processor features include:

- 32kB instruction Cache, 32kB data Cache, all Cache memory is protected by ECC
- Memory Protection Unit (MPU), configurable with up to 16 memory protection regions
- Double-precision and single-precision floating-point FPU
- ETM support
- Efficient DSP instructions

2.1.2 MPU

The MPU has configurable memory protection attributes. It allows the definition of up to 16 protected regions, which can be divided into up to 8 independent subregions, where region address, size, and attributes can be configured.

Protection ranges from 32B to 4GB of addressable memory. When illegal access occurs, a memory management exception is generated.

2.2 Memory

N32H760 series devices feature on-chip Flash, configurable embedded SRAM, and external memory interfaces such as FEMC, SDRAM, and xSPI2. The configurable architecture provides flexibility to partition memory resources according to application needs, allowing appropriate performance trade-offs in terms of application code size, data size, and power saving. In addition, embedded ROM is used as the initial bootloader and for secure boot.

2.2.1 Embedded SRAM

TCM RAMs (only for Cortex-M7)

TCM RAM consists of 1MB SRAM, which can be configured as ITCM-RAM, DTCM-RAM and AXI-SRAM2/3. Software can flexibly configure D-TCM and I-TCM sizes, with the remaining SRAM automatically configured as AXI-SRAM2/3, in granularity of 128KB. ITCM RAM is mapped to address 0x0000 0000, and can only be accessed by the Cortex®-M7 CPU and MDMA (even when the CPU is in sleep mode). DTCM RAM is mapped at address 0x2000 0000, and can also only be accessed through the Cortex®-M7 CPU core and MDMA.

AXI SRAM

Up to 1152KB of AXI RAM, which can be accessed by byte (8-bit), half-word (16-bit), word (32-bit) or double word (64-bit). AXI SRAM is divided into the following types:

- 128KB of AXI SRAM 1 mapped to address 0x2400 0000
- Up to 512KB of AXI RAM 2 (shared with ITCM and DTCM), mapped to address 0x2402 0000
- Up to 512KB of AXI RAM 3 (shared with ITCM and DTCM), mapped to address 0x240A 0000

AHB SRAM

Up to 352KB of AHB SRAM1-5, which can be accessed by byte, half-word (16-bit) or word (32-bit). AHB SRAM is divided into the following types:

- 128 KB of AHB SRAM1 mapped to address 0x3000 0000
- 128 KB of AHB SRAM2 mapped to address 0x3002 0000
- 32 KB of AHB SRAM3 mapped to address 0x3004 0000
- 32 KB of AHB SRAM4 mapped to address 0x3004 8000
- 32 KB of AHB SRAM5 mapped to address 0x3005 0000

AHB SRAM 5 is divided into two blocks, shared with CANFD1-8, used as CANFD data frame buffer.

Backup SRAM

Backup SRAM is located in AHB bus domain 2, mapped to address 0x3800 0000, and can be accessed by byte, half-word (16-bit) or word (32-bit).

Error Correction Code (ECC)

All internal system RAM includes error correction code (ECC). It can be programmatically configured through their respective ECC monitor (ECCMON) modules. The ECC mechanism is based on the SECDED algorithm, supporting single-bit and double-bit error detection as well as single-bit error correction.

SRAM data protection with ECC:

- 7 ECC bits added for each 32-bit word
- For ITCM-RAM and AXI_SRAM1, 8 ECC bits added for each 64-bit word

2.2.2 Embedded ROM

The N32H760 series devices have a 32KB embedded ROM, mapped to address 0x1FFF0000. It contains a small bootloader, which is divided into two parts: secure code and API. The secure code can only be accessed by the Cortex- M7, while the API can be called by the core CPU.

2.2.3 On-Chip Flash

The maximum capacity of the on-chip Flash is 4MB. The first 128KB is used for BOOTPATCH and option bytes, and the remaining space is used for user application code. When operating in XIP mode, the on-chip Flash supports real-time decryption of AES128 through the RTAD module. The decryption applies to any data stored in Flash.

2.3 System Boot Modes

By default, the system boots to the Cortex®-M7 after reset. The BOOTROM program supports two modes: Boot Application and Serial Download. These modes can be selected via the Boot pins and option bytes:

- **Boot Application:** After the BOOTROM program runs normally, the application image is launched from the internal Flash/TCM/SRAM based on the BOOTADDR_M7 value in the option bytes.
- **Serial Download:** The BOOTROM program receives the application image via USART1 or USB1 and stores it in internal Flash/TCM/SRAM.

Table 2-1 Boot mode

| BOOT pin | Option Bytes (OTP_SYS_CFG_BT_M) | Mode | Description |
|----------|---------------------------------|------------------|--|
| 0 | !0x5AA5 and !0x4884 | Boot Application | boot from on-chip Flash/TCM/SRAM |
| 1 | !0x5AA5 and !0x4884 | Serial Download | Built communication with Host by UART or USB |
| * | 0x5AA5 | Boot Application | boot from on-chip Flash/TCM/SRAM |
| * | 0x4884 | Serial Download | Built communication with Host by UART or USB |

2.4 Power Supply Scheme

External Power Supplies:

VDD, VDDA, VREF, VBAT, VDDSMPS, VDDLDO, VDD33USB, VDDDSI.

- **VDD** is the main chip power supply, primarily powering the power system and clock system.
- **VDDA** is the analog peripheral power supply, mainly supplying power to analog peripherals.
- **VREF** provides a reference voltage to analog peripherals for higher accuracy.
- **VBAT** connects to a battery and supplies power to the backup domain.
- **VDDSMPS** is the power input for the DC-DC SMPS (Switched-Mode Power Supply).
- **VDDLDO** powers the main LDO (Low Dropout Regulator), supported only on applicable models; otherwise, it is left NC (not connected).

- **VDD33USB** powers the USB PHY.
- **VDDDSI** powers the MIPI-DSI PHY.

There are **five power domains**, each supplied by an external power source for different regions:

- **VDD Domain:**
Voltage range: 1.8V to 3.63V.
Powers: SMPS, Main LDO, most GPIOs, HSE, HSI, PLL, POR/PDR, BOR, PVD, USB PHY, DSI PHY, etc.
- **VDDA Domain:**
Voltage range: 1.8V to 3.63V.
Powers: ADC, DAC, COMP, VREFBUF, TS, etc.
- **VDDBK Domain:**
Voltage range: 1.8V to 3.63V.
Powers: WKUP pins, NRST, PC13/14/15, LSE, LSI, etc.
- **VDDD Domain:**
Voltage: 0.9V or 0.8V.
Powers: CPU, SRAM, RCC, TRNG, USB PHY digital section, DSI PHY digital section, and most peripherals. The VDDD domain is subdivided into **VDDDRET** and **VDDDMAIN** subdomains:
 - **VDDDRET Domain:**
Powers LPUART, LPTIMER, EXTI, etc., with power supplied from VDDD and controlled by a separate power switch.
 - **VDDDMAIN Domain:**
Directly powers buses (AXI, AHB, APB), bus adapters, low-speed communication interfaces (SPI, I2C, UART), timers (ATIMER, GTIMER, BTIMER), and includes the following subdomains:
 - **CM7 Subdomain:** Contains CM7 core, TCM memory, and its controller.
 - **MDMA Subdomain:** Contains the MDMA.
 - **HRTIM1 Subdomain:** Contains the digital circuit of HRTIMER 1.
 - **HRTIM2 Subdomain:** Contains the digital circuit of HRTIMER 2.
 - **HRTIMAFE Subdomain:** Contains the shared analog front end for HRTIMER1 and HRTIMER2.
 - **HSC1 Subdomain:** Contains high-speed communication interfaces USB1 and Ethernet 1.
 - **HSC2 Subdomain:** Contains USB2, Ethernet 2, and SDMMC2.
 - **GRAPHICS Subdomain:** Contains GPU, DVP1, DVP2, LCDC, JPEG CODEC, and MIPI-DSI modules.Except for the CM7 core subdomain, which is controlled by hardware, all other subdomain power switches are controlled by software.
- **VDDDBK Domain:**
Voltage: 0.9V or 0.8V.
Powers: PWR, Backup SRAM, RTC, WKUP pins, NRST, PC13/14/15, backup IOM, IWDG, RCC_BKP, and backup registers.

2.5 Reset

An internal Power-On Reset (POR) and Power-Down Reset (PDR) circuit is integrated. This circuit remains active at all times, ensuring that the system operates correctly when the supply voltage exceeds 1.8V.

When **VDD** falls below the defined threshold (VPOR/PDR), the device is forced into a reset state, eliminating the need for an external reset circuit.

2.6 Programmable Voltage Detector

A **Programmable Voltage Detector (PVD)** is built in. It monitors the **VDD** power supply and compares it with a threshold voltage **VPVD**.

When VDD drops below or rises above VPVD, an **interrupt** is generated. The interrupt handler can then issue a warning. The PVD feature must be **enabled by software**.

For specific values of **VPOR/PDR** and **VPVD**, refer to **Table 4-9**.

2.7 Low Power Modes

The N32H760 supports five low-power modes:

- **SLEEP Mode**

In SLEEP mode, only the CPU is stopped. All peripherals remain operational and can wake the CPU through interrupts or events.

- **STOP0 Mode**

STOP0 is based on the Cortex-M7F deep sleep mode. It allows lower power consumption while maintaining the contents of SRAM and registers. In this mode, all high-speed clocks such as PLL, HSI, and HSE are turned off. Wake-up sources: Any signal configured as EXTI (external interrupt), including 16 external EXTI lines (I/O-related), PVD output, LPTIMER, LPUART, RTC wake-up, or RTC alarm.

- **STOP2 Mode**

STOP2 mode is based on the Cortex-M7F deep sleep mode. In this mode:

- CPU internal registers are retained, and the contents of the TCM or SRAM used by the running program are not lost.
- The main power domain (VDDDMAN) is powered down, which helps achieve lower power consumption compared to STOP0 mode.
- All high-speed clocks in the main domain, such as PLL, HSI, and HSE, are shut down.
- The retention domain (VDDDRET) remains powered, allowing peripherals like LPUART and LPTIMER to operate using low-speed clocks (LSE or LSI).
- The backup domain (VDDDBKP) is also powered, so peripherals such as RTC and IWDG can function normally.

- **STANDBY Mode**

- STANDBY mode achieves the lowest power consumption among all low-power modes:
- The internal voltage regulator is turned off.
- Oscillators such as PLL, HSI RC oscillator, and HSE crystal oscillator are shut down.
- The retention domain (VDDDRET) is powered down, so most register contents are lost.
- Backup registers are retained, and backup SRAM can optionally be retained.
- The backup domain (VDDDBKP) circuitry remains operational.

- **Wake-up sources include:**

- External reset signal on the NRST pin
- IWDG (Independent Watchdog) reset
- Edge on the WKUP pin
- RTC wake-up event or RTC alarm

- **VBAT Mode**

VBAT mode is entered automatically whenever VDD is powered down but VBAT is still supplied.

In VBAT mode, most I/O pins enter high-impedance state, except: NRST, WKUP, PC13_TAMPER, PC14, PC15

Wake-up condition: Power-up on VDD

2.8 Reset and Clock Control (RCC)

The RCC manages the generation of all clocks, clock gating, and the control of system and peripheral resets. It provides high flexibility in the selection of clock sources and allows the application of clock ratios to optimize power consumption.

2.8.1 Clock Management

The device integrates three internal oscillators, two oscillators with external crystal or resonator, and four PLLs. The RCC (Reset and Clock Control) has the following clock source inputs:

- **HSI64:** 64 MHz internal high-speed oscillator
The control logic of this oscillator resides in the standby power domain. After initial power-on and upon wake-up from low-power modes (STOP0, STOP2, and STANDBY), this clock is used as the **default system clock**.
- **MSI:** 16 MHz medium-speed oscillator
The control logic of this oscillator resides in the retention power domain. In STOP2 power mode, this clock is used as a high-speed clock by peripherals in the retention domain. It can also be selected as a system clock and core clock for certain peripherals.
- **HSE:** 4 ~ 48 MHz external high-speed oscillator
The control logic of this oscillator resides in the core power domain. This clock can be selected as the system clock, peripheral core clock, or reference clock for certain PHYs (e.g., USB, DSI...).
- **LSI:** 32 kHz internal low-speed oscillator
The control logic of this oscillator resides in the standby power domain. It is the first clock switched to during system power-on and is used by the PWR block in the standby domain to start up the system and wake it from standby and STOP2 modes. It is also used by peripherals in the standby and retention power domains.
- **LSE:** 32.768 kHz external low-speed oscillator
The control logic of this oscillator resides in the standby power domain. It provides a **low-power and accurate clock** to peripherals in the standby and retention power domains.
- **PLL:** 430 MHz ~ 1.25 GHz Phase-Locked Loops
The control logic of the PLLs resides in the core power domain. HSI64, MSI, and HSE can be configured as the input clock source for the PLLs. There are **four PLLs**:
 - **PLL1:** Maximum frequency 600 MHz, used by some peripherals as a system clock source and core clock source.
 - **PLL2:** Maximum frequency 800 MHz, used by some peripherals as a system clock source and core clock source.
 - **PLL3:** Maximum frequency 800 MHz, used by some peripherals as a core clock source.
 - SHRPLL maximum frequency is 1.25 GHz, this PLL is used by the SHRTIMER peripheral as the core clock source.

The clock outputs of PLL1, PLL2, and PLL3 are further divided by configurable digital dividers, and then used as system clocks or peripheral core clocks. The SHRPLL clock output is divided by 4 within the AFE, generating a 312.5 MHz clock for the SHRTIMER peripheral.

2.8.2 System Reset Sources

A system reset resets all registers to their reset values, except for reset flags in the reset status register and certain registers in the standby domain (these registers can only be reset by programming the BDRST register and by a standby domain POR reset).

System resets can originate from the following sources:

- Main power domain **POR** (Power-On Reset) from **PWR** and **AFE**.
- **NRST** pin.
- **POR reset** from **PWR** and **AFE** (main domain).
- **IWDG** and **WWDG** reset requests.
- Reset request from the **CPU**.
- **EMC** reset request.
- **Low-power reset** request from **PWR**.
- **BOR** reset (Brown-Out Reset).
- **MMU** reset request

2.9 Bus Interconnect Matrix

These devices feature one AXI bus matrix, two AHB bus matrices, and bus bridges, enabling interconnection between bus masters and bus slaves.

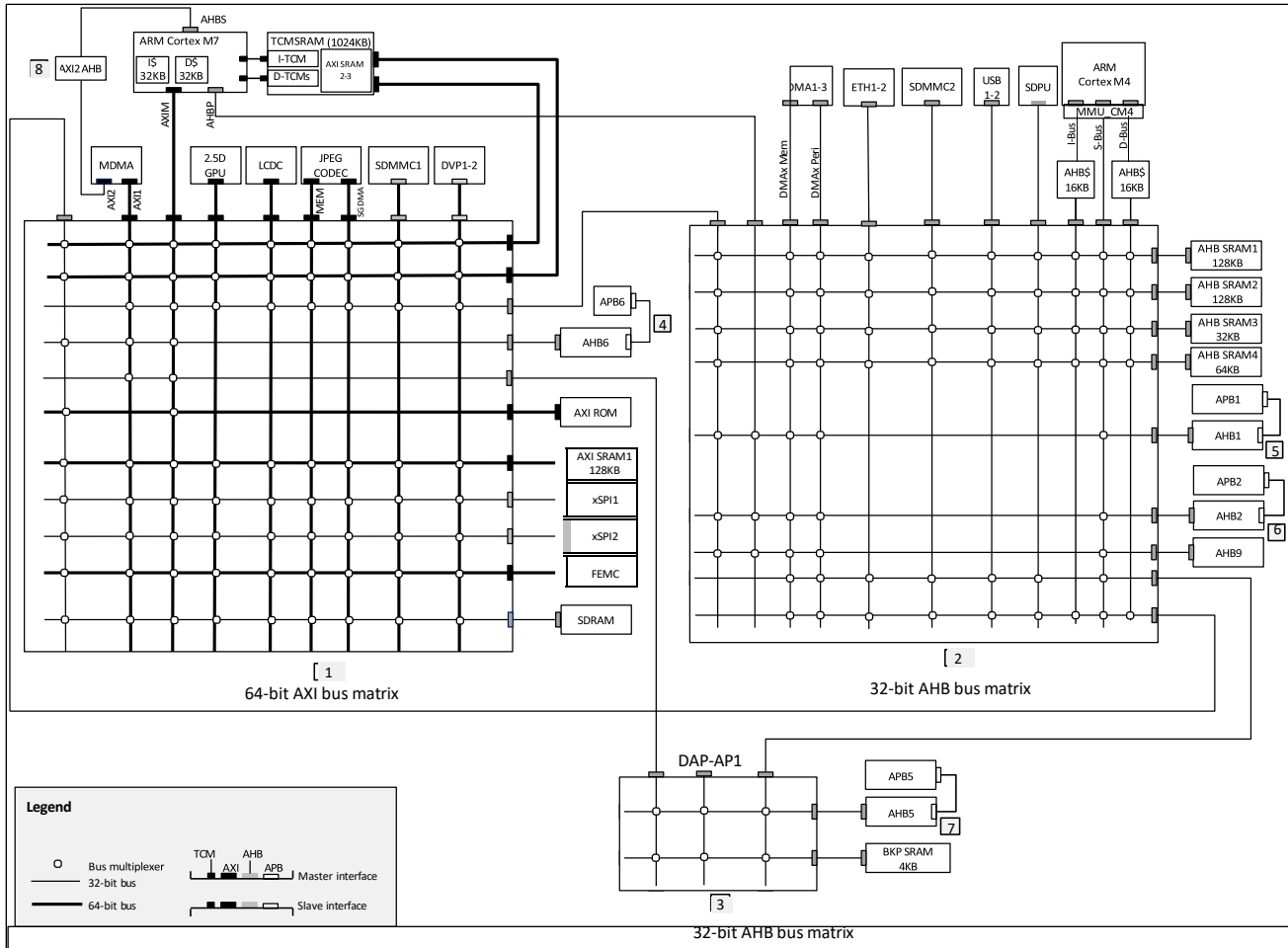
Figure 2-1 Bus Matrix Architecture

2.10 General-Purpose Input/Output Interface (GPIO) and Alternate Function Interface (AFIO)

GPIO refers to General-Purpose Input/Output interface, and AFIO refers to Alternate Function Interface. The chip supports up to 168 GPIO pins, which are divided into 11 groups

(GPIOA/GPIOB/GPIOC/GPIOD/GPIOE/GPIOF/GPIOG/GPIOH/GPIOI/GPIOJ/GPIOK). Each group has 16 ports.

GPIO ports share pins with other alternate peripheral functions. Users can configure them flexibly according to requirements. Each GPIO pin can be independently configured as output (push-pull or open-drain), input (floating, pull-up, or pull-down), or alternate peripheral function port. Except for analog function pins, other GPIO pins have high current-carrying capacity.

GPIO ports have the following characteristics:

- Each GPIO port can be individually configured by software into the following modes:
 - Floating input
 - Pull-up input

- Pull-down input
- Analog function
- Open-drain output, with configurable pull-up/pull-down
- Push-pull output, with configurable pull-up/pull-down
- Push-pull alternate function, with configurable pull-up/pull-down
- Open-drain alternate function, with configurable pull-up/pull-down
- Independent set or clear functions
- All IOs support external interrupts
- All IOs support low-power mode wake-up, with configurable rising or falling edge
 - 16 EXTIs are available for STOP0 mode wake-up, all IOs can be multiplexed as EXTI
 - PA0/PA2/PC1/PC13/PI8/PI11 can be used for STANDBY mode wake-up
- Support for software remapping of IO alternate functions
- Support for GPIO locking mechanism, which can only be cleared by reset after locking

Each I/O port bit can be programmed arbitrarily through the AHB interface, but I/O port registers must be accessed as 32-bit words, 16-bit half-words, or 8-bit bytes (AFIO registers only support 32-bit word access).

2.11 Nested Vectored Interrupt Controller (NVIC)

The device has an embedded Nested Vectored Interrupt Controller (NVIC). The

NVIC includes the following features:

- 234 maskable interrupt channels
- 16 programmable priority levels

2.12 External Interrupt/Event Controller (EXTI)

外 The External Interrupt/Event Controller (EXTI) controls wake-up through configurable and direct event inputs from on-chip peripherals or external outputs. It sends wake-up events to the PWR and transmits interrupt and event signals to both CPUs.

EXTI wake-up requests allow the system to wake up from STOP0 and STOP2 modes, and can also wake up CPUs from CSLEEP, CSTOP0, and CSTOP2 modes. Interrupt requests and event requests can also be used in Run mode. The EXTI includes the following features:

- Wakes up the system from STOP0 and CSTOP2 modes
- Generates interrupts and events for transmission to CPUs

These requests can be generated from the following event inputs:

- Direct events (generated by on-chip peripherals, event flags are stored or cleared in the source peripheral, not in the EXTI) have the following characteristics:
 - Fixed rising edge triggering

- Have interrupt and event mask bits
- Configurable events (generated from external devices or on-chip peripherals, only producing pulse events) have the following characteristics:
 - Software triggering
 - Both rising edge and falling edge triggering are allowed and configurable
 - Have interrupt and event mask bits

2.13 DMA Request Multiplexer (DMAMUX)

Peripherals indicate the presence of a DMA transfer request by setting their DMA request signal. The DMA controller processes the DMA request and generates a DMA acknowledgment signal, and the corresponding DMA request signal will also become invalid, but the DMA request remains pending until then.

The DMAMUX request multiplexer can reconfigure (route) DMA request lines between the product's peripherals and the DMA controller. This routing function is ensured through a programmable multi-channel DMA request line multiplexer. Each channel can select a DMA request line without restrictions, or select a DMA request line in synchronization with events from its DMAMUX synchronization input. Additionally, the DMAMUX can also be used as a DMA request generator for programmable events of its input trigger signals.

The main features are as follows:

Table 2-2 DMAMUX Input/Output

| Feature | DMAMUX1 | DMAMUX2 |
|---|---------|----------------------------|
| Number of DMAMUX synchronization inputs | 9 | 1 (internal use or unused) |
| Number of DMAMUX peripheral requests | 210 | 4 |
| Number of DMAMUX request trigger inputs | 26 | 38 |
| Number of DMAMUX request generator channels | 8 | 16 |
| Number of DMAMUX output request channels | 24 | 16 |

- Each DMA request generator channel has:
 - DMA request trigger input selector
 - DMA request counter
 - Event overflow flag for the selected DMA request trigger input
- Each DMA request multiplexer channel output has:
 - Up to 210 input DMA request lines from peripherals
 - Up to 3 DMA request line outputs
 - Synchronization input selector
 - DMA request counter
 - Event overflow flag for the selected synchronization input
 - An event output for DMA request linking
- AHB slave interface, burst not supported, only 32-bit access
- DMAMUX overflow interrupt

2.14 DMA Controller (DMA)

The DMA controller is controlled by the CPU and can perform fast data transfers from source to destination. Once configured, data transfers occur without CPU intervention. This frees the CPU to perform other computational/control tasks or reduce the system's overall power consumption.

The chip has three DMA controllers (DMA1, DMA2, DMA3), each with 8 logical channels. Each logical channel processes memory access requests from one or more peripherals. An internal arbiter controls the priority of different DMA channels.

The main features are as follows:

General Features

- Compliant with AMBA 2.0 standard
- AHB slave interface for DMA programming
- Channels
 - Up to eight channels, one channel per source and destination
 - Unidirectional channels—data transfer in one direction only
 - Programmable channel priority
- AHB master interface
 - Up to four independent AHB master interfaces, allowing:
 - Up to four simultaneous DMA transfers
 - Masters can be located on different AHB layers (multi-layer support)
 - Source and destination can be on different AHB layers (pseudo fly-by performance)
 - Configurable data bus width for each AHB master interface (up to 256 bits)
 - Configurable byte ordering for master interfaces
- Transfers
 - Support for memory-to-memory, memory-to-peripheral, peripheral-to-memory, and peripheral-to-peripheral DMA transfers
 - DMA transfers between APB peripherals via the APB bridge
- Configurable identification registers
- Component ID parameters for configurable software driver support
- Configuration for DesignWare AHB Lite systems
- Last beat DMA burst indication
- Support for little-endian, address-invariant (AI) big-endian scheme, and BE-32 (word-invariant) scheme for data access on AHB slave interface and each AHB master interface
- Arbitration scheme to determine which request line gets access to a specific master bus interface

Address Generation

- Programmable source and destination addresses (on AHB bus)
- Address increment, decrement, or fixed
- Multi-block transfers implemented through:
 - Linked list (block chaining)
 - Automatic reload of channel registers
 - Contiguous addressing between blocks
- Independent source and destination selection for multi-block transfer types
- Scatter/gather

Channel Buffering

- Single FIFO per channel for source and destination
- Configurable FIFO depth
- D flip-flop-based FIFO
- Automatic data packing or unpacking to accommodate FIFO width

Channel Control

- Programmable source and destination for each channel
- Programmable transfer type per channel (memory-to-memory, memory-to-peripheral, peripheral-to-memory, peripheral-to-peripheral)
- Programmable burst transaction size per channel
- Programmable enable and disable of DMA channels
- Support for disabling channels without losing data
- Support for pausing DMA operations
- Support for RETRY, SPLIT, and ERROR responses
- Programmable maximum burst transfer size per channel
- Configurable maximum transaction size for gate optimization
- Configurable maximum block size for gate optimization
- Bus locking—programmable at transaction, block, or DMA transfer level
- Channel locking—programmable at transaction, block, or DMA transfer level
- Hardcoded multi-block transfer type options
- Option to disable writeback of channel control registers at end of each block transfer

Transfer Initiation

- Handshaking interface for source and destination peripherals (up to 8)
 - Hardware handshaking interface
 - Software handshaking interface
 - Peripheral interrupt handshaking interface

- Handshaking interface supports single or burst DMA transactions
- Polarity control for hardware handshaking interface
- Enable and disable individual DMA handshaking interfaces

Flow Control

- Programmable flow control at block transfer level (source, destination, or DMA controller)
- Software control of source data prefetch when destination is the flow controller

Interrupts

- Consolidated and separate interrupt requests
- Interrupts occur when:
 - DMA transfer (multi-block) completes
 - Block transfer completes
 - Single and burst transactions complete
 - Error conditions
- Support for interrupt enabling and masking

Low Power Modes

- Global clock gating
- Channel-specific clock gating

2.15 MDMA Controller (MDMA)

MDMA is a highly configurable, highly programmable, high-performance, multi-master multi-channel DMA controller that uses AXI as the data transfer bus interface.

The main features are as follows:

General Features

- Independent core, slave interface, and master interface clocks
- Up to 24 channels, one channel per source and destination
- Unidirectional data transfers only (each channel is unidirectional)
- Up to two AXI master interfaces:
 - Two master interfaces supporting multiple layers
 - Multiple AXI master interfaces can connect directly to peripherals on different AXI interconnects, improving bus performance
 - Support for different ACLK on different AMBA layers
- Memory-to-memory, memory-to-peripheral, peripheral-to-memory, and peripheral-to-peripheral DMA transfers
- Separate external memory interface (per channel) for connecting SRAM or register file-based memory to channel FIFO
- AMBA 3 AXI/AMBA 4 AXI compatible master interfaces

- AHB/APB4 slave interface for DMA controller programming
 - AHB slave interface supports only single transfers (hburst = 3'b000)
- AXI master data bus width up to 512 bits (applicable to both AXI master interfaces)
- Static or dynamic selection of endian mode for AXI master interfaces
- Input pins for dynamic endian selection
- Configurable independent control of endian mode for linked list access on master interfaces
- Optional identification registers
- Support for channel locking
 - Support for internal channel arbitration locking the master bus interface at different transfer levels
- DMAC status indication output
 - Idle/busy indication
- DMA hold function
- Output pin indicating the last write transfer at DMA transaction level
- Multi-level DMA transfer hierarchy
 - DMA transfers divided into transaction level, block level, and complete DMA transfer level
- Support for AXI unaligned transfers
- Support for context-sensitive low-power options
- Support for unique ID functionality, generating AXI read/write transfers with unique IDs on AXI read/write channels

Channel Buffering

- One FIFO per channel
- FIFO depth
- Automatic packing/unpacking of data to accommodate FIFO width

Channel Control

- Programmable transfer type per channel (memory-to-memory, memory-to-peripheral, peripheral-to-memory, and peripheral-to-peripheral)
- Single or multiple DMA transactions
- Programmable multi-transaction size per channel
- Programmable maximum AMBA burst transfer size per channel
- Disabling channels without losing data
- Channel pause and resume
- Programmable channel priority
- Internal channel arbitration locking the master bus interface at different transfer levels
- Programmable multi-block transfers using linked lists, contiguous addressing, auto-reload, and shadow register methods

- Dynamic extension of linked lists
- Independent configuration of SRC/DST multi-block transfer types
- Multiple state machines, one each for SRC and DST per channel
- Independent state machines for data and LLI access
- Control signals such as cache and protection programmable for each DMA block
- Programmable transfer length (block length)
- Error status registers for debugging when errors occur

Flow Control

- Programmable flow control at DMA transfer level
 - DMA controller is the flow controller at DMA block transfer level if the size of the block transfer is known before DMA initialization
 - Either source peripheral or destination peripheral is the flow controller for undefined length (demand mode) DMA block transfers if the size of the DMA block transfer is not known before DMA initialization

Handshaking Interface

- Programmable software and hardware handshaking interfaces for non-memory peripherals
- Up to 64 hardware handshaking interfaces/peripherals
- Programmable mapping between enabling/disabling individual handshaking interface peripherals and channels; many-to-one mapping with only one peripheral active at a time
- Memory-mapped registers to control DMA transfers in software handshaking mode

Interrupt Outputs

- Consolidated and separate interrupt outputs
- Interrupt generation:
 - DMA transfer completion
 - Block transfer completion
 - Single or multiple transaction completion
 - Error conditions
 - Channel pause or disable
- Interrupt enabling and masking

Bus Interface

- Master interfaces using AMBA 3 AXI and AMBA 4 AXI protocols, slave interfaces using AHB, AXI4-Lite, and APB 3 protocols
- Data bus width up to 512 bits for master interfaces
- Outstanding transactions on master interfaces
- Setting outstanding transaction limits per channel on master interfaces
- Configurable AXI transfer width

- Out-of-order transaction support for different channels connected to the same master interface; transactions for a specific channel are always initiated in order
- Incremental and fixed address transfers on master interfaces
- Source address and destination address data transfers; must be aligned with respective transfer widths
- Data bus width of 32/64 bits for slave interfaces
- Transfer size (width) used by slave interfaces; must be the same as the data bus width

Security Features

- Parity protection feature for all common registers and channel-specific registers at interface level, with data integrity checking through parity
- Error Correction Code (ECC) protection feature correcting single-bit errors and detecting double-bit errors, enabled to prevent data corruption
 - ECC protection feature for FIFO memory interfaces
 - ECC protection feature for UID memory interfaces
 - ECC protection feature for AXI master interfaces
- Lock-step functionality for safety-critical applications, increasing security and reliability to withstand adverse operating conditions such as Single Event Upsets (SEU) and extreme EMI/EMC

2.16 AES Real-Time Decryption (RTAD)

Main features are as follows:

- Real-time 128-bit decryption (single or multiple) during XSPI memory-mapped read operations.
 - Uses AES in Counter (CTR) mode, with a key stream FIFO queue (depth = 4).
 - Supports any read size.
 - Physical address of the read is used for encryption/decryption.
 - Up to four independent encrypted regions.
 - Region definition granularity: 4096 bytes.
 - Region configuration write lock mechanism.
 - Two optional decryption modes: Execute-Only and Never-Execute.
 - Each region has its own 128-bit key, two-byte firmware version, and eight-byte application-defined nonce. At least one of these must change each time the application performs encryption.
- Confidentiality and integrity protection for encryption keys.
 - Write-only registers, with software lock mechanism.
 - 8-bit CRC provided as public key information.
- Supports xSPI prefetch mechanism.
- In Execute-Only mode, an enhanced encryption mode can be selected, adding a proprietary protection layer on top of the AES stream cipher.

- AMBA AHB slave peripheral, accessible only through 32-bit word single accesses (otherwise an AHB bus error is generated, and write accesses are ignored).

2.17 SDRAM (Synchronous Dynamic Random Access Memory)

Supports an SDRAM controller connected to the AHB bus, capable of accessing up to two external SDRAM/LPSDRAM memory devices.

Main features are as follows:

- Two SDRAM memory devices that can be configured independently
- Data bus width of 8-bit, 16-bit, or 32-bit
- 13-bit row address, 11-bit column address, 4 internal memory banks: 4x16Mx32bit (256 MB), 4x16Mx16bit (128 MB), 4x16Mx8bit (64 MB)
- Configurable row address of 11-bit, 12-bit, or 13-bit; configurable column address of 8-bit, 9-bit, 10-bit, or 11-bit
- Supports word, half-word, and byte access
- Automatic row and bank boundary management
- Supports burst mode
- Write access protection
- Programmable timing parameters
- Supports software reset
- SDRAM power-up initialization via software
- CAS latency of 1, 2, 3
- Supports automatic refresh operations with programmable refresh rate
- Supports suspend and resume via software

2.18 Filter Algorithm Accelerator (FMAC)

The Filter Mathematics Acceleration Unit is used for arithmetic operations on vectors, including a multiplier, accumulator, and address generation logic capable of indexing vector elements in local memory. This unit supports input and output circular buffers to facilitate digital filters such as Finite Impulse Response (FIR) and Infinite Impulse Response (IIR).

The unit frees the processor from frequent or lengthy filtering operations, allowing it to perform other tasks. In many cases, it can accelerate such calculations compared to software implementations, thus speeding up time-critical tasks. Main features are as follows:

- 16 x 16-bit multiplier
- 24 + 2-bit accumulator, with addition and subtraction capabilities
- 16-bit fixed-point input and output data
- 256 x 16-bit data buffer

- Up to three data buffers can be defined in memory (two inputs, one output), defined by programmable base address pointers and associated size registers
- Input and output buffers can be used cyclically
- Filter functions: FIR, IIR (direct form 1)
- Vector functions: dot product, convolution, correlation
- Supports DMA read and write operations

2.19 CORDIC Coprocessor (CORDIC)

The CORDIC hardware computation unit provides hardware acceleration for mathematical functions (primarily trigonometric functions). It is commonly used to accelerate mathematical function calculations in applications such as motor control, metering, and signal processing.

Main features are as follows:

- Supports rotation and vector calculation modes
- Supports circular and hyperbolic coordinate systems
- Once calculation begins, any read operation to result registers puts the bus in a wait state until calculation completes, allowing results to be read after completion without polling or interrupts
- Supports acceleration of 10 functions: sine, cosine, sinh, cosh, atan, atan2, atanh, modulus, square root, natural logarithm
- Supports fixed-point and floating-point data input/output modes
- Supports interrupt, polling, and DMA read/write modes
- Configurable iteration precision

2.20 Sigma-Delta Modulator Digital Filter Unit (DSMU)

The DSMU is a high-performance module for connecting external Σ - Δ modulators, featuring 8 external digital serial channels and 4 flexibly configurable Sigma-Delta digital filters that can provide up to 24-bit final ADC resolution. The external serial channels can be configured as SPI interfaces or Manchester-encoded single-wire interfaces (with configurable parameters) to accommodate various modulators. It also supports internal parallel data input channels for receiving 16-bit parallel data streams from ADC peripherals or device memory.

The DSMU can operate in single conversion mode or continuous mode and provides analog watchdogs with independently configurable digital filters, as well as short-circuit detection, extremum detection, and other functions. It also supports two power modes: normal mode and stop mode.

Main features of the DSMU are as follows:

- 8 configurable external digital serial input channels:
 - Supports SPI interface for connecting various Σ - Δ modulators
 - Supports Manchester-encoded single-wire interface
 - Supports output clock for external Σ - Δ modulators

- 8 internal digital parallel input channels:
 - Up to 16-bit resolution
 - Data sources: ADC data or memory (CPU/DMA) data stream
- 4 configurable data signal processing units:
 - 1 Sincx filter: filter order/type (1..5), oversampling ratio (up to 1..1024)
 - 1 integrator: oversampling ratio (1..256)
- Up to 24-bit signed data output
 - Final output data right-aligned (0..31 bits)
- Signed data output
- Automatic data offset correction (offset written by user to specified register)
- Supports continuous or single conversion
- Conversion start supports the following synchronization methods:
 - Software trigger
 - Internal timer
 - External event
 - Synchronized conversion with the first DSMU filter (DSMU_FLT0)
- Supports analog watchdog
 - Low and high thresholds can be configured separately
 - Supports independently configurable Sincx digital filter (filter order = 1..3, oversampling ratio = 1..32)
 - Configurable data source: output data register, one or more serial digital input channels
 - Continuous data monitoring independent of normal conversion
- Supports short-circuit detector for detecting saturated analog input data (below negative threshold or above positive threshold)
 - 8-bit counter for detecting 1..256 consecutive 0s or 1s in the data stream
 - Continuous monitoring of each channel (8 serial channel transceiver outputs)
- Brake signal can be generated after analog watchdog events or short-circuit detection events
- Supports extremum detection
 - Automatic storage of maximum and minimum output data values
 - Software refresh
- Supports pulse jump function for beam-forming applications (similar to delay line)
- Supports DMA reading of conversion data
- Supports interrupts: end of conversion, out-of-bounds, analog watchdog, short circuit, channel clock missing
- Supports regular and injected conversions
 - Regular conversions can be performed at any time, even in continuous mode without affecting injected conversions

- Injected conversions enable precise timing and have high priority

2.21 Real-Time Clock (RTC)

The RTC is a set of continuously running counters with an integrated calendar clock module that provides perpetual calendar functionality, along with alarm interrupts and periodic interrupt capabilities.

Main features are as follows:

- Real-Time Clock (RTC) is an independent BCD timer/counter
- Software support for Daylight Saving Time compensation
- Programmable periodic auto-wakeup timer
- Two 32-bit registers containing hours, minutes, seconds, year, month, date, weekday
- Independent 32-bit register containing sub-seconds
- Two programmable alarms
- Two 32-bit registers containing programmable alarm hours, minutes, seconds, year, month, date, weekday
- Two independent 32-bit registers containing programmable alarm sub-seconds
- Digital precision calibration function
- Reference clock detection: a more precise external clock source (50 or 60Hz) can be used to improve calendar accuracy
- Three configurable tamper detection events with filtering and internal pull-up, five internal tamper detection events
- Timestamp function
- 32 backup registers that retain data in low-power modes
- Multiple interrupt/event wakeup sources, including Alarm A, Alarm B, wakeup timer, timestamp, tamper
- RCC register enables the RTC module and as long as voltage remains within operating range, the RTC never stops in any mode (including RUN mode, SLEEP mode, STOP0 mode, STOP2 mode, STANDBY mode, and VBAT mode)
- RTC provides multiple wakeup sources that can wake the MCU from all low-power modes (SLEEP mode, STOP0 mode, STOP2 mode, and STANDBY mode)

2.22 Analog/Digital Converter (ADC)

The 12-bit ADC is a high-speed analog-to-digital converter using successive approximation. There are 3 ADCs in total, with ADC1/ADC2 capable of forming a dual ADC configuration, and ADC1/ADC2/ADC3 capable of forming a triple ADC configuration. Each ADC has up to 20 multiplexed channels, and A/D conversion on each channel can be performed in single, continuous, scan, or discontinuous modes. ADC conversion values are stored (left-aligned/right-aligned) in 16-bit data registers. Input voltages can be monitored through analog watchdogs 1/2/3 to detect if they are within user-defined high/low thresholds, and the maximum input clock frequency for the ADC is 20MHz.

The main features of the ADC are described as follows:

- Supports 3 ADCs with single-ended and differential inputs
- Supports 12-bit and 10-bit resolution
- Supports triggered sampling, including EXTI/TIMER
- Each ADC has 3 analog watchdogs
- Interrupts can be triggered when ADC is ready, sampling complete, conversion complete, or analog watchdog 1/2/3 events
- Supports 4 conversion modes:
 - Single conversion
 - Continuous conversion
 - Discontinuous mode
 - Scan mode
- Supports self-calibration
- Data alignment with embedded data consistency
- Independently programmable sampling time intervals for all channels
- Supports management of single-ended or differential inputs (programmable by channel)
- ADC operating clock derived from PLL clock or AHB clock
- Data can be managed by DSMU, DMA
- Regular channel conversion based on FIFO implementation
- Conversion start methods:
 - Start regular and injected conversions through software
 - Start regular and injected conversions through polarity-configurable external triggers (GPIO input events or internal timer events)
- Oversampling:
 - Adjustable oversampling ratios: x1, x2, x4, x8, x16, x32, x64, x128, x256, x512, x1024
 - Configurable right shift 0-10 bits
 - 16-bit data result register
- Data preprocessing:
 - Supports gain compensation
 - Supports offset compensation
- Multi-ADC modes:
 - Dual ADC mode: combination of ADC1 and ADC2
 - Triple ADC mode: combination of ADC1, ADC2, and ADC3
- ADC operating voltage between 1.7V and 3.6V
- ADC supports conversion of voltages between VREF- and VREF+

2.23 Digital-to-Analog Converter (DAC)

The DAC is a digital-to-analog converter, primarily taking digital input and producing voltage output. DAC data is available in either 8-bit or 12-bit modes and supports DMA functionality. When configured in 12-bit mode, DAC data can be left-aligned or right-aligned; when configured in 8-bit mode, DAC data is right-aligned. Each DAC has an independent converter that can perform conversions independently. In dual DAC mode, each DAC can either operate independently or two DACs (DAC1&DAC2, DAC3&DAC4 as pairs) can perform conversions and updates simultaneously. VREF+ is input through a pin as the DAC reference voltage, providing higher precision for DAC conversion data.

When DAC output is internally connected to on-chip peripherals, the DACx_OUT pin can be used as a general-purpose input/output (GPIO). The DAC output buffer can be selectively enabled to obtain high driving output current.

Main features include:

- Supports 4 DACs, each corresponding to an independent DAC converter
- Supports 8-bit or 12-bit output, with data in 12-bit mode available in both right-aligned and left-aligned formats
- Dual DAC supports synchronous or independent conversion
- Each DAC supports DMA functionality and DMA underflow error detection
- DMA dual data mode to save bus bandwidth
- Noise wave, triangular wave, and sawtooth wave generation
- DAC output supports connection to on-chip peripherals
- Buffer offset calibration
- Input reference voltage supports VREF+
- External event triggered conversion

2.24 Analog Comparator (COMP)

The COMP module is used to compare the magnitude of two input analog voltages and output a high/low level based on the comparison result. When the voltage at the "INP" input terminal is higher than the voltage at the "INM" input terminal, the comparator outputs a high level. When the voltage at the "INP" input terminal is lower than the voltage at the "INM" input terminal, the comparator outputs a low level.

The main functions of the comparator are as follows:

- 4 independent comparators
- Two built-in 64-level programmable comparison voltage reference sources VREF1 and VREF2
- Supports filter clock and filter reset
- Output polarity can be configured as high or low
- Supports 4 programmable hysteresis levels
- Comparison results can be output to I/O ports or trigger timers for capture events, OCREF_CLR events, brake events, and interrupt generation
- Input channels can multiplex I/O ports, VREF1, VREF2, and general 12-bit DAC channel outputs
- Can be configured as read-only or read-write; when locked, reset is required to unlock

- Supports blanking, with configurable blanking sources
- COMP1/COMP2 and COMP3/COMP4 can form window comparators
- Can wake up the system from Sleep mode by generating interrupts
- Configurable filter window size
- Configurable filter threshold size
- Configurable sampling frequency for filtering

2.25 Voltage Reference Buffer (VREFBUF)

The chip has a built-in voltage reference buffer that can be used as a voltage reference for ADC, 12bit-DAC, and COMP internal 6bit-DAC. It can also be used as a voltage reference for external components through the VREF+ pin.

2.26 Timers and Watchdogs

The chip supports up to 2 advanced timers, 7 general-purpose timers A, 3 general-purpose timers B, 4 basic timers, 5 low-power timers, as well as 1 independent watchdog timer, 1 window watchdog timer, and 1 system tick timer.

The following table compares the functions of advanced timers, general-purpose timers, basic timers, and low-power timers:

Table 2-3 Timer Function Comparison

| Timer | Counter Resolution | Counter Type | Capture/Compare Channels | Capture/Compare Channels | Complementary Output |
|----------|--------------------|-------------------|-----------------------------|--------------------------|----------------------|
| ATIM1~2 | 16-bit | Up, Down, Up/Down | Any integer between 1~65536 | 4 | 4 |
| GTIMA1~7 | 16-bit | Up, Down, Up/Down | Any integer between 1~65536 | 4 | None |
| GTIMB1~3 | 16-bit | Up, Down, Up/Down | Any integer between 1~65536 | 4 | 1 |
| BTIM1~4 | 32-bit | Up | Any integer between 1~65536 | 0 | None |
| LPTIM1~5 | 16-bit | Up | 1, 2, 4, 8, 16, 32, 64, 128 | 0 | None |

2.26.1 Super High-Resolution Timer (SHRTIM)

Supports two super high-resolution timers

High-resolution timers can generate up to 12 highly precise digital timing signals, primarily used for driving power conversion systems such as switch-mode power supplies or lighting systems, but can also be used for applications requiring extremely high time resolution.

The timer adopts a modular architecture and can generate independent or coupled waveforms. Waveforms are determined by independent timing signals (using counters and comparison units) and various external events (such as analog or digital feedback and synchronization signals), enabling the generation of a wide variety of control signals (PWM, phase shift, constant Ton...) to meet the needs of most conversion topologies.

For control and monitoring purposes, the timer also has timing measurement functions and is connected to built-in ADC and DAC converters. Additionally, the timer has a light load management mode and can handle various fault mechanisms to achieve safe shutdown.

Main features:

- **Multiple timing units**
 - 100ps resolution, all outputs support full resolution, with adjustable duty cycle, frequency, and pulse width in triggered single-pulse mode
 - 6 16-bit timing units (each timing unit includes 1 independent counter and 5 comparison units (comparison unit 5 dedicated to ADC triggering))
 - 12 outputs controllable by any timing unit, with up to 32 set/reset sources per channel
 - Modular structure meets the needs of various independent converters with 1 or 2 switches, as well as some large multi-switch topologies
- **Up to 10 external events, usable for any timing unit**
 - Programmable polarity and edge validity
 - 10 events for fast asynchronous mode
 - 10 events for programmable digital filtering
 - Pseudo-event filtering using blanking and window modes
 - All 10 external events fully mapped to any GPIO or any analog comparator
- **Multiple channels connected to built-in analog peripherals**
 - 10 trigger signals for ADC converters, ADC trigger signals fully mappable to any comparison unit
 - 3 trigger signals for DAC converters
 - 7 comparators for analog signal conditioning
- **Rich protection mechanisms**
 - 6 fault inputs can be used in combination and associated with any timing unit
 - All 6 fault inputs fully mappable to any analog comparator
 - Programmable polarity and edge validity, digital filters
 - Specialized delay protection for resonant converters
- **Multiple SHRTIM instances can be synchronized with external synchronization inputs/outputs**
- **Multifunctional output stage**
 - Full resolution time insertion
 - Programmable output polarity

- Chopper mode
- **Burst mode controller, capable of handling light load operations on multiple converters simultaneously, supporting 32-bit burst mode counting**
- **8 interrupt vectors, each with up to 14 sources**
- **7 DMA requests, with up to 14 sources, enabling multi-register updates through burst mode**

2.26.2 Advanced Timer (ATIM1~4)

Advanced control timers (ATIMx) are mainly used for: counting input signals, measuring input signal pulse width, and generating output waveforms. Advanced timers feature complementary outputs, dead-time insertion, and brake functions. They are suitable for motor control.

Main features include:

- 16-bit auto-reload counter (can implement up counting, down counting, up/down counting)
- 16-bit programmable prescaler (division factor configurable to any value between 1 and 65536)
- Programmable repetition counter
- Up to 9 channels for ATIMx
- 4 capture/compare channels, operating modes: PWM output, output compare, one-pulse mode output, input capture
- 2 brake input signals with digital filtering support
- Interrupts/DMA generated when the following events occur:
 - Update event
 - Trigger event
 - Input capture
 - Output compare
 - Brake signal input
- Complementary outputs with programmable dead time
 - For ATIMx, channels 1, 2, 3, and 4 support this feature
- Timer control via external signals
- Multiple timers internally connected to achieve timer synchronization or linking
- Incremental (quadrature) encoder interface: for tracking running trajectory and decoding rotational position
- Hall sensor interface: for three-phase motor control
- Trigger input as external clock or for cycle-by-cycle current management

2.26.3 General-Purpose Timer (GTIMA1~7)

General-purpose control timers (GTIMAx) are mainly used for: counting input signals, measuring input signal pulse width, and generating output waveforms.

Main features include:

- 16-bit auto-reload counter (can implement up counting, down counting, up/down counting)

- 16-bit programmable prescaler (division factor configurable to any value between 1 and 65536)
- Up to 4 channels for GTIMAx
- Channel operating modes: PWM output, output compare, one-pulse mode output, input capture
- Interrupts/DMA generated when the following events occur:
 - Update event
 - Trigger event
 - Input capture
 - Output compare
- Timer control via external signals
- Multiple timers internally connected to achieve timer synchronization or linking
- Incremental (quadrature) encoder interface: for tracking running trajectory and decoding rotational position
- Hall sensor interface: for three-phase motor control

2.26.4 General-Purpose Timer (GTIMB1~3)

General-purpose control timers (GTIMBx) are mainly used for: counting input signals, measuring input signal pulse width, and generating output waveforms. General-purpose timers (GTIMBx) feature complementary outputs, dead-time insertion, and brake functions.

Main features include:

- 16-bit auto-reload counter (can implement up counting, down counting, up/down counting)
- 16-bit programmable prescaler (division factor configurable to any value between 1 and 65536)
- Programmable repetition counter
- Up to 5 channels for GTIMBx
- 4 capture/compare channels, operating modes: PWM output, output compare, one-pulse mode output, input capture
- 1 brake input signal with digital filtering support
- Interrupts/DMA generated when the following events occur:
 - Update event
 - Trigger event
 - Input capture
 - Output compare
 - Brake signal input
- Complementary outputs with programmable dead time
 - For GTIMBx, channel 1 supports this feature
- Timer control via external signals
- Multiple timers internally connected to achieve timer synchronization or linking
- Incremental (quadrature) encoder interface: for tracking running trajectory and decoding rotational position

- Hall sensor interface: for three-phase motor control
- Trigger input as external clock or for cycle-by-cycle current management

2.26.5 Basic Timer (BTIM1~4)

Basic timers include a 32-bit auto-reload counter. Main features include:

- 32-bit auto-reload up-counting counter
- 16-bit programmable prescaler (division factor configurable to any value between 1 and 65536)
- Events generating interrupts/DMA:
 - Update event

2.26.6 Low-Power Timer (LPTIM1~5)

LPTIM is a 16-bit timer with multiple clock sources that can continue running in all power modes. LPTIM can operate without an internal clock source and can be used as a "pulse counter." Additionally, LPTIM can wake up the system from low-power modes, implementing a "timeout function" with extremely low power consumption.

Main features include:

- 16-bit up counter
- 3-bit prescaler, 8 division factors (1, 2, 4, 8, 16, 32, 64, 128)
- Multiple clock sources:
 - Internal clock sources: LSE, LSI, HSI, MSI, or APB clock
 - External clock source: External clock input through LPTIM Input1 (operates without LP oscillator running, used for pulse counter applications)
- 16-bit auto-reload register (LPTIM_ARR)
- 16-bit compare register (LPTIM_CMP)
- Continuous or single-trigger counting mode
- Programmable software or hardware input trigger
- Programmable digital filter for glitch filtering
- Configurable output (PWM)
- Configurable IO polarity
- Encoder mode
- Pulse counting mode, supporting single-pulse counting, dual-pulse counting (quadrature and non-quadrature)

2.26.7 Watchdog Timer (WDG)

Built-in independent watchdog (IWDG) and window watchdog (WWDG) timers solve problems caused by software errors. Watchdog timers are very flexible to use, improving system security and timing control accuracy.

Independent Watchdog (IWDG)

The Independent Watchdog (IWDG) is driven by the low-speed internal clock (LSI clock) running at 32KHz, and it can continue to run even when dead loop events or MCU hangs occur. This provides a higher level of security, timing accuracy, and watchdog flexibility. It can solve system failures caused by software faults through reset. IWDG is most suitable for applications that require the watchdog to run as a completely independent process outside the main application but with lower timing precision requirements.

Main features include:

- Independent 12-bit down counter
- RC oscillator provides an independent clock source, can work in SLEEP, STOP0, and STANDBY modes
- Can match reset and low-power wake-up
- System reset when the down counter reaches 0x000 (if the watchdog is activated)

Window Watchdog (WWDG)

The Window Watchdog (WWDG) clock is derived from the APB1 clock frequency divided by 4096, and it detects program abnormalities through time window configuration. Therefore, WWDG is suitable for precise timing and is commonly used to monitor software failures caused by external interference or unforeseeable logical conditions that cause applications to deviate from their normal operating sequence.

Main features include:

- 14-bit independent programmable down counter
- When WWDG is enabled, reset occurs in the following cases:
 - When the down counter value is less than 0x40
 - When the counter value after decrement is greater than the window register value during reload
- Early wake-up interrupt

2.27 I²C Bus Interface

I2C (Inter-Integrated Circuit) bus is a widely used bus structure that uses only two bidirectional lines: the data bus (SDA) and the clock bus (SCL). Through these two lines, all I2C bus-compatible devices can communicate directly with each other.

The I2C bus interface handles communication between the microcontroller and the serial I2C bus. It provides multi-master functionality and can control all I2C bus-specific sequences, protocols, arbitration, and timing. It supports Standard Mode (Sm), Fast Mode (Fm), and Fast Mode Plus (Fm+). It is also compatible with SMBus (System Management Bus) and PMBus (Power Management Bus). The I2C interface module also supports DMA mode, which can effectively reduce CPU load.

The main features of the I2C interface are described as follows:

- I2C bus specification v3 compatibility:
 - Slave mode and master mode
 - Multi-master functionality
 - Standard Mode (up to 100 kHz) / Fast Mode (up to 400 kHz)

- Fast Mode Plus (up to 1 MHz) / High-Speed Mode (up to 3.4 MHz)
- 7-bit and 10-bit addressing modes
- Multiple 7-bit slave addresses (2 slave address registers, 1 with configurable mask segment)
- All 7-bit address acknowledge mode
- Broadcast call
- Software-configurable data setup and hold times on the bus
- Interrupts and clock stretching
- SMBus specification v3.0 compatibility:
 - Hardware CRC (packet error checking) generation and verification with ACK control
 - Command and data acknowledgment control
 - Support for Address Resolution Protocol (ARP)
 - Host and device support
 - SMBus alert
 - Timeout and idle state detection
- PMBus rev 1.3 standard

Other features:

- Programmable buffer up to 8 bytes / burst buffer with DMA
- Programmable analog and digital noise filters
- Independent clock source, making I2C communication speed unaffected by i2c_pclk reprogramming

2.28 Flexible External Memory Controller (FEMC)

The Flexible External Memory Controller (FEMC) is used to access various off-chip memory devices. It allows for convenient expansion of different types of large-capacity static memory according to application needs, enabling the simultaneous expansion of multiple different types of static memory without adding external interfaces. All external memories share the address, data, and control signals output by the FEMC controller, and the FEMC distinguishes different external devices through a unique chip select signal.

Main features include:

- Supports external expansion of the following devices:
 - SRAM
 - PSRAM
 - ROM
 - NOR Flash
 - NAND Flash (SLC)
 - LCD (8080/6800)
- Supports two NAND flash blocks, hardware 1bit-ECC can detect up to 2KB of data
- Supports burst access mode for synchronous devices, such as NOR flash and PSRAM

- Supports 8/16/32-bit data bus
- Each memory block has independent chip select control
- Various devices can be supported through timing programming
- Automatically converts 64-bit AXI access requests to consecutive 32-bit or 16-bit or 8-bit access requests based on the data width of the external memory, to communicate with external 32-bit or 16-bit or 8-bit memory devices
- Supports write enable and byte select output for PSRAM and SRAM devices
- External asynchronous wait control
- Supports low-power management

2.29 Universal Synchronous Asynchronous Receiver Transmitter (USART)

The Universal Synchronous Asynchronous Receiver Transmitter (USART) is a full-duplex serial data exchange interface that supports synchronous or asynchronous communication. It can be flexibly configured to facilitate full- duplex data exchange with various external devices.

The USART interface transmit and receive baud rates are configurable, and it also supports continuous communication via DMA. USART also supports multi-processor communication, LIN mode, synchronous mode, single-wire half- duplex communication, smart card asynchronous protocol, IrDA SIR ENDEC functionality, and hardware flow control. Main features include:

- Supports full-duplex, asynchronous communication
- Supports single-wire half-duplex communication
- Configurable baud rate, with maximum baud rate up to 37.5Mbit/s
- Supports 8x or 16x oversampling
- Supports 8-bit or 9-bit data frames
- Supports two internal FIFOs for transmitting and receiving data
- Supports 1-bit or 2-bit stop bits
- Supports hardware-generated parity bits and parity checking
- Supports hardware flow control: RTS, CTS
- Supports RS-485
- Supports DMA transmit and receive
- Supports multi-processor communication: enters silent mode if address doesn't match, can be awakened by idle bus detection or address identification
- Supports synchronous mode, allowing user control of bidirectional synchronous serial communication in master mode
- Supports smart card asynchronous protocol, compliant with ISO7816-3 standard
- Supports Serial Infrared Protocol (IrDA SIR) encoding and decoding, providing normal and low-power operating modes
- Supports LIN mode

- Supports multiple clock error detection: data overflow error, frame error, noise error, parity error
- Supports multiple interrupt requests: transmit data register empty, CTS flag, transmission complete, data received, data overflow, bus idle, parity error, LIN mode break frame detection, and noise flag/overflow error/frame error in multi-buffer communication

Mode configuration:

| Communication Mode | USART1-USART7 | UART9-UART15 |
|--------------------------------|---------------|--------------|
| Asynchronous Mode | Y | Y |
| Multi-processor | Y | Y |
| LIN | Y | Y |
| Synchronous Mode | Y | N |
| Single-wire Mode (Half-duplex) | Y | Y |
| Smart Card Mode | Y | N |
| IrDA Infrared Mode | Y | Y |
| DMA Communication Mode | Y | Y |
| Hardware Flow Control Mode | Y | Y |

Y = Mode supported, N = Mode not supported

2.30 Low-Power Universal Asynchronous Receiver Transmitter (LPUART)

The Low-Power Universal Asynchronous Receiver Transmitter (LPUART) is a low-power, full-duplex, asynchronous serial communication interface. LPUART can be clocked by LSE, HSE, HSI, MSI, SYSCLK, and PCLK. When the 32.768kHz LSE is selected as the clock source, LPUART can operate in STOP0/2 low-power modes with a maximum communication rate of up to 9600bps. LPUART supports wake-up by receiving data. By configuring wake-up events, the CPU in STOP0/2 mode can be awakened.

At the same time, when the MCU is working in RUN mode, LPUART can also be used as a regular asynchronous serial port. Users can switch the clock source to HSI, SYSCLK, and PCLK to achieve higher communication speeds. The main features of LPUART are as follows:

- Full-duplex asynchronous communication
- Selectable HSI, HSE, LSE, MSI, SYSCLK, or PCLK clock sources
- Fractional baud rate generator system: programmable baud rate up to 5Mbits/s shared between transmit and receive; baud rates from 300bps to 9600bps when using a 32.768 kHz clock source (LSE)
- Fixed 8-bit data word length, 1 stop bit, and optional 1 parity bit
- Supports DMA data transfer
- Supports hardware flow control
- Transmission detection flags: receive buffer full, receive buffer half-full, receive buffer not empty, receive buffer overflow, transmission complete, transmit buffer full, transmit buffer half-full, transmit buffer not empty
- Parity control: parity selection, parity can be disabled
- Error detection flags: parity error, overflow error, noise error
- 32-byte receive buffer, 8-byte transmit buffer
- Low-frequency baud rate error correction
- Configurable sampling method with 1 or 3 samples

- Noise detection
- Configurable RTS threshold for flow control
- Supports configurable source modes in STOP0/2 mode: start bit detection, receive buffer not empty detection, one configurable receive byte (1~32 bytes), and programmable 8-byte frame

2.31 Flexible Data-rate Controller Area Network (FDCAN)

The FDCAN module complies with the ISO 11898-1:2015 standard, supports CAN 2.0A/B and CAN FD protocols, and is compatible with the non-ISO standard Bosch protocol.

In addition, the CAN modules FDCAN1&2&3&4 also support Time-Triggered CAN (TTCAN) as specified in ISO 11898-4, including event-synchronized time-triggered communication, global system time, and clock drift compensation. FDCAN1&2&3&4 include additional registers dedicated to time-triggered functionality. CANFD can optionally be used with event-triggered and time-triggered CAN communication.

The FDCAN modules share two message RAM areas, and each FDCAN can freely select SRAM5 BANK1 or SRAM5 BANK2 for receive message filters, receive FIFOs, receive buffers, transmit buffers, transmit event FIFOs (and TTCAN triggers). The message RAM is located in the MCU's internal SRAM, with configurable start addresses, and a single FDCAN can be allocated up to 4480 words (32-bit).

Main features include:

- Complies with ISO 11898-1:2015 and ISO 11898-4 standards
- Supports CAN FD with up to 64 bytes of data
- Supports fully hardware-implemented TTCAN Level 1 and Level 2 (only supported by FDCAN1/2/3/4)
- Supports CAN error logging
- Supports AUTOSAR standard
- Supports SAE J1939 standard
- Enhanced receive filter functionality
- Two configurable receive FIFOs
- Separate signal indication when receiving high-priority messages
- Up to 64 dedicated receive buffers
- Up to 32 dedicated transmit buffers
- Configurable transmit FIFO or queue
- Configurable transmit event FIFO
- Supports configurable message RAM, shared by 8 FDCAN controllers
- Programmable loopback test mode
- Maskable module interrupts
- Two clock domains: CAN core clock and APB bus clock
- Supports power-down mode

2.32 Serial Peripheral Interface/Inter-IC Sound Bus (SPI/I2S)

SPI allows chips to communicate with external devices in half/full duplex, synchronous, serial mode. SPI can be configured in master mode and multi-master mode, and provides communication clock (SCK) for external slave devices. It can be used for various purposes, including dual-line simplex synchronous transmission using a single bidirectional data line, and also supports hardware CRC verification.

I2S is also a synchronous serial interface communication protocol. It supports four audio standards, including Philips I2S standard, MSB and LSB aligned standards, and PCM standard. In half-duplex communication, it can work in both master and slave modes. When acting as a master device, it can provide clock signals to external slave devices through the interface.

The main features of the SPI interface are as follows:

- Full-duplex and simplex synchronous modes
- Support for master mode, slave mode and multi-master mode
- Support for 8-bit or 16-bit data frame formats
- Programmable data bit order
- Hardware or software chip select management
- Configurable clock polarity and clock phase
- Hardware CRC calculation and verification support for transmission and reception
- Support for DMA transfer function
- 8-byte receive/transmit FIFO

The main features of the I2S interface are as follows:

- Half-duplex and full-duplex synchronous modes
- Support for master mode and slave mode operation
- 4 audio standards supported: Philips I2S standard, MSB-aligned standard, LSB-aligned standard, and PCM standard
- Configurable audio sampling frequency, ranging from 8KHz to 192KHz
- Configurable steady-state clock polarity
- MSB data direction
- Support for DMA transfer function
- Support for multiple selectable clock sources

2.33 Multi-line Serial Peripheral Interface (xSPI)

xSPI is an interface for single/dual/quad/octal line SPI peripheral communication. It can operate in two modes: indirect mode and memory-mapped mode.

Supported modes:

- Indirect mode: all operations executed using xSPI registers

- Memory-mapped mode: external flash is mapped to the microcontroller address space, allowing the system to treat it as internal storage

Main features:

- Data communication supports single/dual/quad/octal line modes
- Supports Single SPI/Normal SPI, DUAL SPI, QUAD SPI, Dual-QUAD, OCTAL SPI modes
- Maximum transfer rate up to 133 MHz
- Supports Motorola SPI:
 - Standard/Dual/Quad/Octal SPI
- Supports Single Data Rate (SDR) and Double Data Rate (DDR) modes
- Read data strobe and data masking support for DDR transfers
- Supports clock extension
- Frame format and operation codes are software configurable in both indirect and memory-mapped modes
- Integrated FIFO for transmission and reception
- Allows 8/16/32-bit data access
- Dedicated 32x32bit TX FIFO and 32x32bit RX FIFO
- Supports DMA
- XIP mode supports SPI read, does not support XIP write
 - Supports continuous transfer mode
 - Supports data prefetching
- Supports automatic code decryption for XSPI peripherals: XSPI peripheral code is stored encrypted, automatically decrypted when executing without affecting peripheral access speed; decryption can be enabled/disabled via software; root key stored in NVR area, not accessible to users
- Supports serial NAND FLASH, NOR FLASH, and PSRAM
- Host mode supports 4 external chip select outputs; slave mode supports 1 chip select input; all IOs that are multiplexed as chip select outputs in host mode can be multiplexed as chip select inputs in slave mode
- Supports multi-master arbitration function

2.34 Universal Serial Bus High-Speed Dual Role Interface (USB_HS_DualRole)

The USB High-Speed Dual Role interface (USB HS Dual Role), referred to as USBHS. The USBHS controller is designed to provide high-speed data transfer and a standard interface for connecting external devices. USBHS supports both Host mode and Device mode and includes an internal USB high-speed PHY that can be configured for high-speed or full-speed operation, eliminating the need for external PHY chips. USBHS can support all four transfer types defined by the USB 2.0 protocol (control transfer, bulk transfer, interrupt transfer, and isochronous transfer). Additionally, USBHS includes an internal DMA that can accelerate data transfer between USBHS and the system as an AHB bus master.

Main features:

- Supports USB 2.0 High-speed (480Mb/s)/Full-speed (12Mb/s)/Low-speed (1.5Mb/s) Host mode
- Supports USB 2.0 High-speed (480Mb/s)/Full-speed (12Mb/s) Device mode
- Supports all 4 transfer types: control transfer, bulk transfer, interrupt transfer, and isochronous transfer
- Built-in high-speed PHY supporting high-speed, full-speed, and low-speed modes without external PHY
- Supports HS SOF, FS SOF, and LS Keep-alive tokens
- SOF pulse can be output through PAD
- SOF pulse internally connected to timer (TIMx)
- Supports A-B device identification (ID line)
- Embedded DMA with software-configurable AHB bulk transfer type
- Power-saving features such as stopping the system during USB suspension, turning off digital module clock, and managing PHY and DFIFO power
- Has 4 KB dedicated RAM
- Contains 16 host channels in Host mode, each supporting any type of USB transfer
- Built-in hardware scheduler in Host mode:
 - Stores up to 16 interrupt plus isochronous transfer requests in periodic hardware queue
 - Stores up to 16 control plus bulk transfer requests in non-periodic hardware queue
- In Host mode, includes one RX FIFO, one periodic transfer TX FIFO, and one non-periodic transfer TX FIFO
- In Device mode, includes 1 bidirectional control endpoint 0, plus 8 IN endpoints and 8 OUT endpoints; both IN and OUT endpoints can be configured for bulk, interrupt, or isochronous transfers
- Device mode includes a shared RX FIFO and a TX-OUT FIFO, plus 9 dedicated TX-IN FIFOs
- Supports soft disconnect function

2.35 Secure Digital Multimedia Card (SDMMC)

SDMMC provides host interface for SD storage cards, SDIO cards, and MMC devices, supporting only one protocol stack version of SD/SDIO/MMC card at a time.

The basic transfer of bus communication is command/response, which directly transfers information in the command or response structure. Data transfers include block mode, SDIO multi-byte mode, and MMC continuous data stream mode.

Main features:

- Compatible with SD Host Controller Standard Specification V3.00
- Compatible with SD Physical Layer Interface Specification V3.00
- Compatible with SDIO Standard Specification V3.00
- Compatible with eMMC Standard Specification V4.51
- Supports 1-bit/4-bit SD card and SDIO modes
- Supports UHS-I interface, requiring level conversion when external devices use 1.8V power supply

- Supports DS, HS, SDR12, SDR25, SDR50, DDR50, and SDR104 transfer modes
- Supports 1-bit, 4-bit, and 8-bit MMC modes and BOOT mode
- Supports single block/multi-block read and write
- Supports maximum block size of 512 bytes in SD&SDIO mode, 2048 bytes in eMMC mode
- EMMC maximum clock frequency 200MHz (limited by maximum I/O frequency), maximum transfer rate up to 1.6Gbps (HS200 mode, 8-bit)
- Fully configurable 2048*2 byte read/write FIFO
- Supports internal dedicated DMA functionality

2.36 DVP Interface

DVP is a flexible and powerful CMOS optical sensor interface that can easily implement customer image acquisition requirements without CPU intervention during the entire acquisition process.

This module can receive high-speed data from traditional or ITU-R BT.656 format CMOS image sensors. It supports data formats: YCbCr422 and RGB565 progressive, compressed data (JPEG).

Main features:

- Pure hardware acquisition method
- Pure input interface
- Supports 8-bit, 10-bit, 12-bit, and 16-bit traditional synchronous parallel interfaces
- Supports 8-bit and 10-bit ITU-R BT.656 video formats
- Supports 8-bit and 16-bit YCbCr, YUV, and RGB data formats
- Supports 8-bit, 10-bit, and 16-bit Bayer data formats
- Supports clock output (via MCO output, typical value 48MHz), providing clock to external CMOS optical sensors
- Input pixel clock DVP_PCLK, frame sync signal DVP_VSYNC, line sync signal DVP_HSYNC polarities can all be independently configured
- Features 16x4 byte FIFO for receiving pixel data
- Supports FIFO overflow protection
- Supports DMA, no CPU intervention required during image acquisition
- Image acquisition size must be a multiple of 4 bytes
- Supports hardware inversion of acquired image data
- Maximum support for 1280*720@30 Hz
- Supports continuous mode and snapshot mode
- Supports hardware cropping
- Supports multiple data formats:
 - YCbCr422 progressive video
 - RGB565 progressive video
 - Compressed data (JPEG)

2.37 Graphics Processing Unit (GPU)

Supports a 2.5D GPU for high-resolution displays in embedded systems. This module is optimized even when processing millions of pixels per frame.

Main features supported by the 2.5D GPU:

- High rendering quality
 - Sub-pixel accurate rendering
 - Direct edge anti-aliasing
 - Primitive edge blur
 - Static dithering during frame buffer writeback can enhance RGB565 output
- High performance
 - 300M pixels/second fill rate (300MHz clock, single pipeline)
 - Prefetch cache
- Hardware accelerated primitives
 - Fast clear/rectangle fill
 - Lines
 - Triangles
 - Quadrilaterals
 - Bezier curves
 - Advanced Blit operations, supporting scaling, stretching, rotation, tinting, and Alpha blending
 - Convolution filtering
- Blending
 - Normal Alpha blending
 - Independent Alpha/color blending
 - Source/destination factors: 0, 1, source Alpha, 1-source Alpha
- Textures
 - Supports 4096 x 4096 texture size
 - Flexible texture color format handling
 - ARGB8888, RGBA888, RGB888, BGR888, ARGB8565, RGBA5658, ARGB4444, RGBA4444, ARGB1555, RGBA5551, RGB565, AL88, AL44, AL17, AL8, AL4, AL2, AL1, ARGB2222, RGBA2222
 - CLUT (Color Look-Up Table) index formats
 - Applicable to all ALx formats
 - RLE texture decompression
 - Texture addressing modes
 - Standard linear

- Scramble
- Reverse scramble
- Virtual tiling
- Frame buffer
 - Supports 4096 x 4096
 - ARGB8888, RGBA888, RGB888, BGR888, ARGB8565, RGBA5658, ARGB4444, RGBA4444, ARGB1555, RGBA5551, RGB565, A8, L8, AL17, ARGB2222, RGBA2222
 - Blending modes: blend, multiply, multiply-add, darken, lighten
- Performance verification
 - Performance counters
 - Visual enumeration efficiency
 - Visual cache burst access length

2.38 Image Codec (JPEG)

Supports a JPEG codec for encoding or decoding uncompressed image data streams in JPEG compression mode, compliant with ISO/IEC 10918-1 standard.

Main features supported by the ENCODER:

- Supports single frame images and Motion JPEG payload
- Supports 8-bit color component sampling
- Supports up to 3 color components
- Supports maximum image size of 64K x 64K
- Supports YCbCr and BW (grayscale) image color spaces
- YCbCr/YUV 4:4:4, 4:2:2, 4:2:0
- Configurable JPEG header generator
- 3 programmable 8-bit quantization tables
- 4 programmable Huffman tables (two AC tables and two DC tables)
- Minimum Coding Unit (MCU) fixed at 8 x 8

Main features supported by the DECODER:

- Supports single frame images and Motion JPEG payload
- Supports 8-bit color component sampling
- Supports up to 3 color components
- Supports maximum image size of 64K x 64K
- Supports YCbCr and BW (grayscale) image color spaces
- YCbCr/YUV 4:4:4, 4:2:2, 4:2:0
- Configurable JPEG header generator
- 3 programmable 8-bit quantization tables

- 4 programmable Huffman tables (two AC tables and two DC tables)

2.39 Ethernet (ETH)

以 The Ethernet module uses dedicated DMA to optimize packet transmission and reception performance. The ETH module supports standard interfaces for communication with the physical layer (PHY): MII, RMII, to enable sending and receiving of Ethernet packets.

Main features:

MAC Tx and Rx Common Features

- Provides independent transmission, reception, and control interfaces for applications
- Supports the following PHY interfaces for 10/100/1000Mbps data transfer rates:
 - MII, for communication with external Fast Ethernet PHY
 - RMII, for communication with external Fast Ethernet PHY
- Half-duplex operation:
 - Supports CSMA/CD protocol
 - Supports backpressure flow control
- 32-bit data transfer interface on application side
- Full-duplex flow control operation (IEEE 802.3x pause packets and priority flow control)
- Supports forced network statistics via RMON or MIB counters (RFC2819/RFC2665)
- Ethernet packet timestamping as described in IEEE 1588-2002 and IEEE 1588-2008 (provides 64-bit timestamp in Tx or Rx status of PTP packets), supports one-step and two-step timestamps in TX direction
- Supports flexible control of second pulse output (PPS)
- Supports MDIO (Clause 22 and Clause 45) master interface for PHY device configuration and management

MAC Tx Features

- Preamble and SFD insertion in the transmit path
- Provides separate 32-bit status for each packet transmitted by application
- Automatic CRC generation and padding bytes (PAD) for each packet transmitted
- Programmable packet length to support standard Ethernet packets or jumbo Ethernet packets up to 16KB
- Programmable inter-packet gap (40~96 bits, with 8-bit steps)
- IEEE 802.3x flow control automatically transmits zero-wait pause packets on transition of flow control input from valid to invalid (in full-duplex mode)
- Source address field insertion or replacement, and VLAN insertion, replacement, and deletion in transmit packets (per-packet control or static-global control)
- Up to two VLAN tags can be inserted, replaced, or deleted
- Transmission of packets with smaller preamble size in full-duplex mode
- Supports queue/channel-based VLAN tag insertion, replacement, or deletion

MAC Rx Features

- Automatic PAD and CRC stripping in receive path
- Preamble and SFD removal in receive path
- Programmable watchdog timeout limit
- Flexible address filtering:
 - 4 perfect 48-bit destination address (DA) filters with byte masks
 - 4 source address (SA) checking filters with byte masks
 - 64-bit hash filter for multicast and unicast (DA) addresses
 - Support for forwarding all multicast address packets
 - Support for promiscuous mode, passing all packets without filtering for network monitoring
 - Status report included with all incoming packets (with each filtering)
- Additional packet filtering:
 - VLAN tag-based: perfect match and hash filtering (filtering based on outer or inner VLAN tag)
 - Layer 3 and Layer 4-based: TCP/UDP based on IPv4/IPv6
- Supports IEEE 802.1Q VLAN tag detection and removal of VLAN tags from received packets
- Detection of wake-up packets and AMD magic packets
- Forwarding received pause packets to application (in full-duplex mode)
- Layer 3/Layer 4 checksum offload for received packets

MTL Tx and Rx Common Features

- 32-bit transaction layer module (connecting application and MAC)
- Performs data transfers using simple FIFO protocol
- Optimizes packet-oriented transfers using packet separators
- Dual-port RAM based on asynchronous FIFO controllers
- Programmable burst length up to half the size of MTL Rx or Tx queue to support burst data transfers in MTL configuration
- Programmable threshold capability for each queue (default threshold 64 bytes)

MTL Tx Features

- 2KB transmit FIFO with programmable threshold capability
- Supports one queue in transmit path
- Store-and-forward mode or threshold mode (cut-through mode)
- Automatic retransmission of collision frames in half-duplex mode
- Drops packets on late collision, excessive collision, excessive deferral, and underrun
- Calculates and inserts IPv4 header checksum and TCP, UDP, or ICMP checksum
- Statistics by generating pulses for packets dropped in transmit FIFO (due to underflow)
- Packet-level control:
 - VLAN tag insertion or replacement

- Ethernet source address segment insertion
- Layer 3/Layer 4 checksum insertion control
- One-step timestamp
- Timestamp control
- CRC and PAD control

MTL Rx Features

- 2KB receive FIFO with configurable threshold
- Supports one queue in receive path
- Inserts Rx status vector into Rx queue after EOP/EOF (threshold mode) and before SOP/SOF
- Programmable Rx queue threshold in threshold mode (cut-through mode) (default fixed 64 bytes)
- In store-and-forward mode, can filter all error packets during reception and not forward them to application
- Supports forwarding runt (under-length) error-free packets
- Statistics by generating pulses for packets lost in receive FIFO (due to overflow)
- Automatically generates pause packet control signals or backpressure signals to MAC based on Rx queue fill level

DMA Features

- 32-bit data transfer
- Separate DMA in transmit path and receive path
- Optimizes packet-oriented DMA transfers with packet separators
- Supports byte-aligned addressing of data buffers
- Supports dual buffer (ring) descriptors
- Descriptor architecture allows transferring large data blocks (up to 32K bytes per descriptor) with minimal CPU intervention
- Comprehensive status reporting for normal operation and transmission errors
- Independently programmable burst lengths for Tx DMA and Rx DMA engines to optimize host bus utilization
- Programmable interrupts for various operating conditions
- Packet-based transmit or receive completion interrupt control
- Supports round-robin or fixed priority arbitration between receive and transmit engines
- Start and stop modes
- Independent ports for host CSR (Control Status Register) access and host data interface
- Supports TCP Segmentation Offload (TSO)

AHB Master Interface Features

- 32-bit data for application data access
- Little-endian mode
- Software-selectable AHB burst type (fixed burst, indefinite burst, or mixed burst)

AHB Slave Interface Features

- 32-bit data for CSR access
- Little-endian mode
- Supports all burst types

Monitoring, Testing, and Debugging Features

- Loopback mode under MII interface for debugging
- DMA status (Tx and Rx) as status bits
- Debug status register showing FSM states and FIFO fill levels in transmit and receive paths
- Application abort status bit
- MMC (RMON) module
- Current Tx or Rx buffer pointer as status register
- Current Tx or Rx descriptor pointer as status register
- Tx or Rx queue memory accessible via slave port for debugging

2.40 Cyclic Redundancy Check Unit (CRC)

The CRC calculation unit can generate CRC calculation results in 8-bit, 16-bit, or 32-bit input data according to specified generating polynomials. In other applications, CRC-based techniques are used to verify data transmission or storage integrity. Within the scope of functional safety standards, they provide a method to verify flash memory integrity. The CRC calculation unit helps calculate software signatures at runtime for comparison with reference signatures generated at link time and stored at given memory locations.

Main features:

- Default use of CRC-32 (Ethernet) generating polynomial: $0x4C11DB7$
 - $X^{32} + X^{26} + X^{23} + X^{22} + X^{16} + X^{12} + X^{11} + X^{10} + X^8 + X^7 + X^5 + X^4 + X^2 + X + 1$
- Supports user-defined generating polynomials with configurable size: 7-bit, 8-bit, 16-bit, or 32-bit
- Can process 8-bit, 16-bit, or 32-bit input data
- Configurable CRC initial value
- Single input or output data register
- Built-in input buffer to avoid bus stalling during calculation
- 32-bit data CRC calculation completed in 4 AHB clock cycles (HCLK)
- Supports general-purpose 32-bit register (available for temporary data storage)
- Configurable input and output data bit order
- Supports XOR operations between input/output data and specified (configurable) data

2.41 EtherCAT Slave Controller (ESC)

The **N32H7651xB7EC** supports an EtherCAT Slave Controller (ESC). Serving as the interface between the EtherCAT fieldbus and the slave application, the ESC is responsible for EtherCAT communication. When using standard Ethernet packets or Ethernet frames (in compliance with IEEE 802.3 standards),

the ESC does not receive, interpret, and replicate process data at each node. Instead, the ESC reads the data specifically addressed to it as the frame passes through the device.

Key features are as follows:

- 2 MII ports for connecting Ethernet PHYs
- 8 Fieldbus Memory Management Units (FMMUs)
- 8 Sync Managers (SMs)
- 8KB process data RAM
- 64-bit Distributed Clock (DC)
- On-chip bus as Process Data Interface (PDI)

2.42 Secure Data Processing Unit (SDPU)

SDPU combines SAC and SDMA modules, with SAC including AES, DES, SM4, SHA, and RNGC (entropy post-processing) algorithms. SDMA transfers computation data from SRAM to SAC and transfers computation results from SAC to SRAM.

SDPU main features:

- Supports DES symmetric algorithm
 - Supports DES and 3DES encryption/decryption operations
 - TDES supports 2KEY and 3KEY modes
 - Supports CBC and ECB modes
- Supports AES symmetric algorithm
 - Supports 128bit/192bit/256bit key lengths
 - Supports CBC, ECB, CTR modes
- Supports SM4 symmetric algorithm
 - Supports CBC, ECB modes
- Supports SHA hashing algorithm
 - Supports SHA1/SHA224/SHA256/SHA384/SHA512
- Supports Random Number Generator (RNG)
 - Supports True Random Number (TRNG) and Pseudo-Random Number (PRNG) modes
 - Supports LSFR129 post-processing
 - Supports XOR combining of all sources
 - Supports FIPS-140 CAVP
- Supports simultaneous operation of RNG and other algorithms
- Supports FIFO configuration
 - Supports algorithm data configuration through FIFO
- Supports SDMA data transfer
 - Supports automatic data transfer from SRAM to SRAM as master data via AHB interface

- Supports SRAM base address transfer through parameters
- Supports maximum data transfer size of 4KB (1024 words)
- Supports data transfer size checking
- Supports CRC16 verification
- SRAM supports maximum 2MB (512K words)
- Supports data reconnection in cases of source/destination address offset = 1/2/3

2.43 Debug Interface (DBG)

Embeds ARM's SWJ-DP interface, enabling software developers to debug and trace embedded firmware using industry-standard debugging tools via JTAG or serial single-wire debug access port. Trace data can be captured through the trace port for recording and analysis.

DBG main features:

- Breakpoint debugging
- Code execution tracing
- Software instructions
- JTAG debug port
- Serial line debug port
- Trigger inputs and outputs
- Serial line trace port
- Synchronous trace port
- Debugging and tracing in low-power modes

3 Pin Definition and Description

3.1 Package Diagram

3.1.1 UFBGA176+25 Pin Distribution

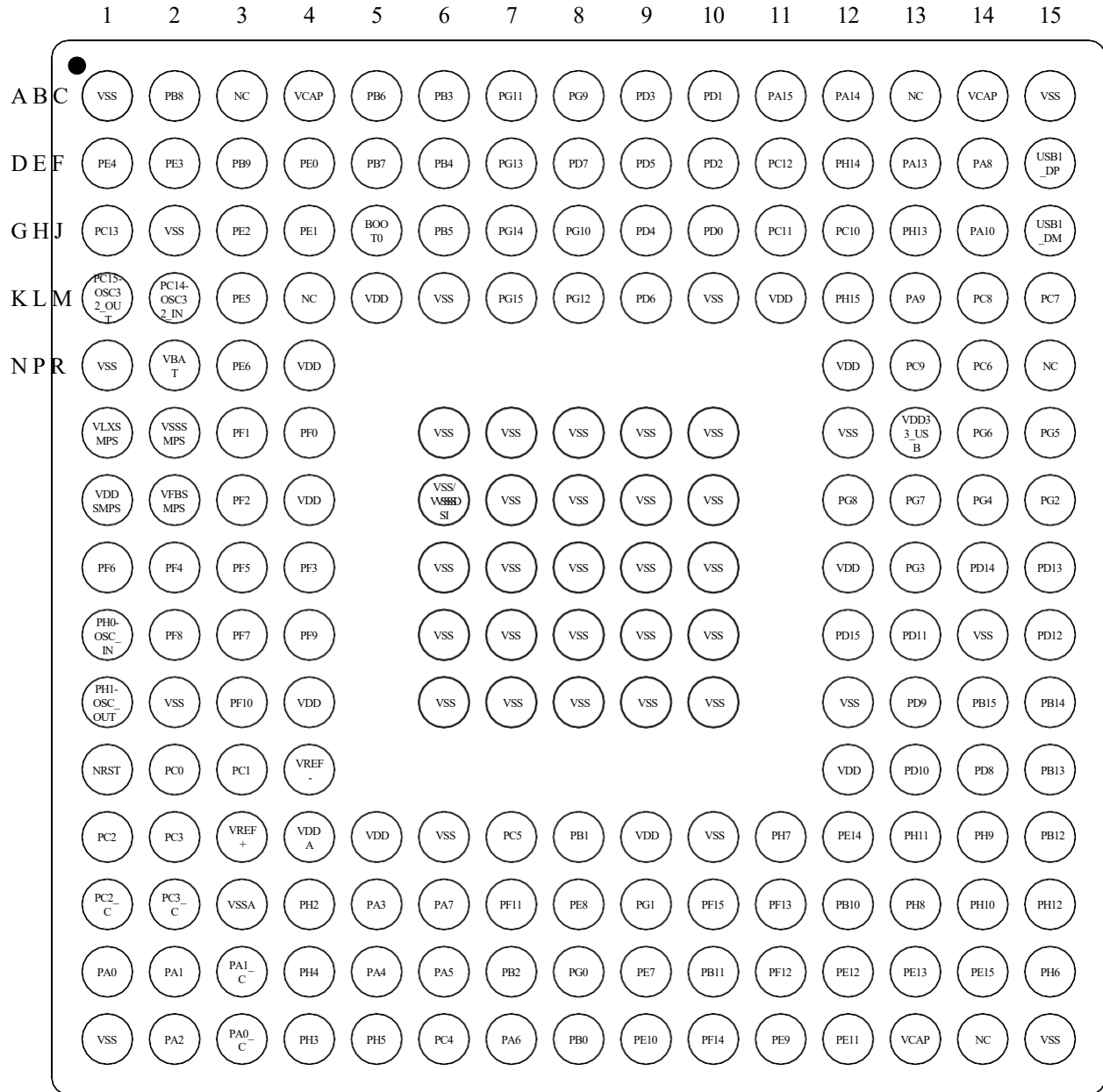

3.2 Pin Multiplexing

Table 3-1 Pin definition

| Package | Pin Name | Typ | I/O structure | Fail-safe ⁽³⁾ support | Optimal Multiplex Function | |
|---------------|----------|-----|---------------|----------------------------------|--|--------------|
| UFBGA176 + 25 | | | | | Default | Redefinition |
| C3 | PE2 | IO | TT | Yes | TRACECLK SPI6_SCK ETH1_MII_TXD3/ETH1_GMII_TXD3 ESC_P0_MII_TXD3 GTIMB1_ETR DVP2_D0 FEMC_A23 USART5_RX FDCAN4_TX | - |
| B2 | PE3 | IO | TT | Yes | TRACED0 ETH1_MII_TXD2/ETH1_GMII_TXD2 ESC_P0_MII_TXD2 SHRTIM2_EEV GTIMB1_BRK DVP2_D1 FEMC_A19 USART5_TX FDCAN4_RX | - |
| B1 | PE4 | IO | FT | Yes | TRACED1 SPI6_NSS ETH2_PHY_INTN ESC_LED_STATE_RUN SHRTIM1_FLT GTIMB1_CH1N DVP1_D4 LCD_B0 FEMC_A20 USART6_RX DSMU_DATIN3 | - |
| D3 | PE5 | IO | TT | Yes | TRACED2 SPI6_MISO xSPI2_NCS1 ESC_EEPROM_CLK GTIMB1_CH1P DVP1_D6 LCD_G0 FEMC_A21 USART6_TX DSMU_CKIN3 | - |
| E3 | PE6 | IO | FT | Yes | TRACED3 SPI6_MOSI ESC_EEPROM_DATA SHRTIM1_EEV ATIM1_BKIN2 GTIMB1_CH2 DVP1_D7 | - |

| | | | | | | |
|-------------|------------------------|----|----|-----|---|-----------|
| | | | | | LCD_G1 FEMC_A22 | |
| A1 | VSS | S | - | - | - | - |
| C2 | VSS | S | - | - | - | - |
| D5 | VDD | S | - | - | - | - |
| E2 | VBAT | S | - | - | VBAT | - |
| C1 | PC13 | IO | FT | Yes | RTC_OUT1 RTC_TAMP1 RTC_TS PWR_WKUP3 | - |
| D2 | PC14- OSC32_I N | IO | FT | Yes | PC14-OSC32_IN | - |
| D1 | PC15- OSC32_O UT | IO | FT | Yes | PC15-OSC32_OUT | - |
| A15/ D10 | VSS | S | - | - | - | - |
| D11 | VDD | S | - | - | - | - |
| F2 | VSSSMP S | S | - | - | - | - |
| F1 | VLXSMP S | S | - | - | - | - |
| G1 | VDDSMPS | S | - | - | - | - |
| G2 | VFBSMPS | S | - | - | - | - |
| F4 | PF0 | IO | TT | Yes | xSPI2_IO0 ETH1_GMII_TXD4 SHRTIM2_CHA1 GTIMA1_CH1 GTIMA5_CH1 DVP2_D0 FEMC_A0 SDRAM_A0 USART1_TX FDCAN4_TX I2C2_SDA I2C5_SDA | COMP3_OUT |
| F3 | PF1 | IO | TT | Yes | xSPI2_IO1 ETH1_GMII_TXD5 SHRTIM2_CHA2 GTIMA1_CH2 GTIMA5_CH2 DVP2_D1 FEMC_A1 SDRAM_A1 USART1_RX FDCAN4_RX I2C2_SCL I2C5_SCL SDRAM_D5 | COMP3_INM |
| G3 | PF2 | IO | TT | Yes | SPI6_NSS xSPI2_IO2 ETH1_GMII_TXD6 SHRTIM2_CHB1 GTIMA1_CH3 GTIMA5_CH3 GTIMB2_ETR DVP2_D2 FEMC_A2 | COMP3_INP |

| | | | | | | |
|----|-----|----|----|-----|---|-------------------------------------|
| | | | | | SDRAM_A2 USART1_CK I2C2_SMBA I2C5_SMBA | |
| H4 | PF3 | IO | TT | Yes | SPI6_SCK xSPI2_IO3 ETH1_GMII_TXD7 SHRTIM2_CHB2 GTIMA1_CH4 GTIMA5_CH4 GTIMB2_CH4 DVP2_D3 FEMC_A3 SDRAM_A3 USART1_CTS/USART1_NSS I2C6_SDA | ADC3_INP5 COMP1_INM |
| H2 | PF4 | IO | TT | Yes | SPI6_MISO xSPI2_CLK/xSPI2_CLKIN ETH2_MII_RX_CLK/ETH2_RMII_REF_CLK ESC_P1_MII_RX_CLK SHRTIM2_CHC1 GTIMA1_ETR GTIMB2_CH3 DVP2_D4 FEMC_A4 SDRAM_A4 USART1_DE/USART1_RTS FDCAN5_TX I2C6_SCL SDRAM_D4 | ADC3_INN5 ADC3_INP9 |
| H3 | PF5 | IO | TT | Yes | SPI6_MOSI xSPI2_NCLK ETH1_GMII_GTX_CLK ESC_P0_MII_RX_CLK SHRTIM2_CHC2 ATIM3_BKIN1 GTIMB2_CH2 DVP2_D5 FEMC_A5 SDRAM_A5 FDCAN5_RX I2C6_SMBA | ADC3_INP4 COMP1_INP |
| E1 | VSS | S | - | - | - | - |
| E4 | VDD | S | - | - | - | - |
| H1 | PF6 | IO | TT | Yes | SPI5_NSS xSPI2_IO3 ETH2_MDIO ESC_MDIO ATIM3_ETR ATIM4_ETR GTIMA5_CH1 GTIMB2_CH1P DVP1_PIXCLK DVP2_D5 UART11_RX FDCAN3_RX | ADC3_INN4 ADC3_INP8 COMP2_INM |
| J3 | PF7 | IO | TT | Yes | SPI5_SCK xSPI2_IO2 ETH2_MDC ESC_MDC ATIM3_CH4 | ADC3_INP3 COMP2_INP |

| | | | | | | |
|----|-------------|-----|------|-----|--|--|
| | | | | | ATIM4_CH3 GTIMA5_CH2 GTIMB3_CH1P DVP2_PIXCLK UART11_TX FDCAN3_TX | |
| J2 | PF8 | IO | TT | Yes | SPI5_MISO xSPI2_IO0 ETH2_MII_COL ESC_P0_MII_RXD0 ATIM3_CH1 ATIM4_CH4 GTIMA5_CH3 GTIMB2_CH1N DVP2_HSYNC SDMMC2_LEDCTRL UART11_DE/UART11_RTS | ADC3_INN3 ADC3_INP7 COMP4_INM |
| J4 | PF9 | IO | TT | Yes | SPI5_MOSI xSPI2_IO1 ETH2_MII_CRS ESC_P0_MII_RXD1 SHRTIM2_FLT ATIM3_CH2 ATIM4_CH1 GTIMA5_CH4 GTIMB3_CH1N DVP2_VSYNC SDMMC1_LEDCTRL UART11_CTS | ADC3_INP2 |
| K3 | PF10 | IO | TT | Yes | xSPI2_CLK/xSPI2_CLKIN ETH2_PPS_OUT ESC_P1_MII_TX_EN SHRTIM2_EEV ATIM3_CH3 ATIM4_CH2 GTIMB2_BRK DVP1_D11 LCD_DE FEMC_A3 | ADC3_INN2 ADC3_INP6 COMP4_INP |
| J1 | PH0-OSC_IN | IO | FT | Yes | PH0-OSC_IN | - |
| K1 | PH1-OSC_OUT | IO | FT | Yes | PH1-OSC_OUT | - |
| L1 | NRST | I-O | NRST | Yes | NRST | - |
| L2 | PC0 | IO | TT | Yes | ETH2_MII_RX_DV/ETH2_RMII_CRS_DV ESC_P1_MII_RX_DV ESC_LATCH0 LCD_G2 LCD_R5 FEMC_A25 FEMC_D12/FEMC_DA12 SDRAM_NWE SDRAM_D12 DSMU_CKIN0 DSMU_DATIN4 | ADC1_INP10 ADC2_INP10 ADC3_INP10 |
| L3 | PC1 | IO | TT | Yes | TRACED0 RTC_TAMP3 PWR_WKUP6 SPI2_MOSI I2S2_SDO | ADC1_INN10 ADC1_INP11 ADC2_INN10 ADC2_INP11 |

| | | | | | | |
|-----|-------|----|----|-----|--|--|
| | | | | | ETH1_MDC ESC_MDC LCD_G5 SDMMC2_CK FEMC_D0/FEMC_DA0 DSMU_CKIN4 DSMU_DATIN0 | ADC3_INN10 ADC3_INP11 |
| M1 | PC2 | IO | TT | Yes | SPI2_MISO I2S2_SDI ETH1_MII_TXD2/ETH1_GMII_T XD2 ESC_P0_MII_TXD2 DVP2_D6 SDRAM_NCE0 DSMU_CKIN1 DSMU_CKOUT | ADC1_INN11 ADC1_INP12 ADC2_INN11 ADC2_INP12 ADC3_INN11 ADC3_INP12 |
| N1 | PC2_C | IO | TT | Yes | - | ADC2_INN1 ADC2_INP0 ADC3_INN1 ADC3_INP0 |
| M2 | PC3 | IO | TT | Yes | SPI2_MOSI I2S2_SDO ETH1_MII_TX_CLK/ETH1_GMII TX_CLK ESC_P0_MII_TX_CLK DVP2_D7 SDRAM_CKE0 DSMU_DATIN1 | ADC1_INN12 ADC1_INP13 ADC2_INN12 ADC2_INP13 |
| N2 | PC3_C | IO | TT | Yes | - | ADC2_INP1 ADC3_INP1 |
| E12 | VDD | S | - | - | - | - |
| F6 | VSS | S | - | - | - | - |
| N3 | VSSA | S | - | - | - | - |
| L4 | VREF- | S | - | - | - | - |
| M3 | VREF+ | S | - | - | - | - |
| M4 | VDDA | S | - | - | - | - |
| P1 | PA0 | IO | TT | Yes | PWR_WKUP1 SPI4_NSS I2S4_WS ETH1_MII_CRS/ETH1_GMII_CR S ESC_P0_MII_RX_DV ATIM2_ETR GTIMA1_CH1 GTIMA1_ETR GTIMA4_CH1 GTIMB1_BRK SDMMC2_CMD FEMC_A19 USART2_CTS/USART2_NSS UART9_TX | ADC1_INP16 |
| R3 | PA0_C | IO | TT | Yes | - | ADC1_INN1 ADC1_INP0 ADC2_INN1 ADC2_INP0 |
| P2 | PA1 | IO | TT | Yes | ETH1_MII_RX_CLK/ETH1_RMII _REF_CLK/ETH1_GMII_RX_CL K ESC_P0_MII_RX_CLK GTIMA1_CH2 GTIMA4_CH2 | ADC1_INN16 ADC1_INP17 |

| | | | | | | |
|----|-------|----|----|-----|---|--------------------------|
| | | | | | GTIMB1_CH1N LPTIM3_OUT LCD_R2 USART2_DE/USART2_RTS UART9_RX | |
| P3 | PA1_C | IO | TT | Yes | - | ADC1_INP1 ADC2_INP1 |
| R2 | PA2 | IO | TT | Yes | PWR_WKUP2 ETH1_MDIO ESC_MDIO ESC_P1_LINK SHRTIM2_EEV GTIMA1_CH3 GTIMA4_CH3 GTIMB1_CH1P LPTIM4_OUT LCD_R1 USART2_TX | ADC1_INP14 ADC2_INP14 |
| N4 | PH2 | IO | TT | Yes | xSPI2_IO4 ETH1_MII_CRS/ETH1_GMII_CR S ESC_LINK_ACT0 ESC_P1_MII_TX_EN SHRTIM2_CHD1 GTIMB3_CH2 LPTIM1_IN2 LCD_R0 SDRAM_CKE0 UART15_RX | ADC3_INP13 |
| G4 | VDD | S | - | - | - | - |
| F7 | VSS | S | - | - | - | - |
| R4 | PH3 | IO | TT | Yes | xSPI2_IO5 ETH1_MII_COL/ETH1_GMII_CO L ESC_P0_MII_RX_ER SHRTIM2_CHD2 GTIMB3_CH3 LCD_R1 SDRAM_NCE0 USART7_CK UART15_TX | ADC3_INN13 ADC3_INP14 |
| P4 | PH4 | IO | FT | Yes | ETH2_MII_TXD0/ETH2_RMII_T XD0 ESC_P1_MII_TXD0 SHRTIM2_CHE1 GTIMB3_CH4 DVP2_HSYNC LCD_G4 LCD_G5 USART7_RX UART15_DE/UART15_RTS FDCAN5_TX I2C2_SCL | ADC3_INN14 ADC3_INP15 |
| R5 | PH5 | IO | TT | Yes | SPI5_NSS ETH2_MII_TXD1/ETH2_RMII_T XD1 ESC_P1_MII_TXD1 SHRTIM2_CHE2 GTIMB3_ETR DVP2_PIXCLK SDRAM_NWE USART7_TX | ADC3_INN15 ADC3_INP16 |

| | | | | | | |
|-----|-----|----|----|-----|--|---|
| | | | | | UART15_CTS FDCAN5_RX I2C2_SDA | |
| N5 | PA3 | IO | TT | Yes | I2S4_MCK ETH1_MII_COL/ETH1_GMII_CO L GTIMA1_CH4 GTIMA4_CH4 GTIMB1_CH2 LPTIM5_OUT LCD_B2 LCD_B5 USART2_RX FEMC_A10 | ADC1_INP15 ADC2_INP15 |
| F8 | VSS | S | - | - | - | - |
| H12 | VDD | S | - | - | - | - |
| P5 | PA4 | IO | TT | No | SPI1_NSS SPI3_NSS SPI4_NSS I2S1_WS I2S3_WS I2S4_WS ESC_LED_RUN GTIMA4_ETR DVP1_HSYNC LCD_VSYNC FEMC_D8/FEMC_DA8 SDRAM_D8 USART2_CK USB2_SOF | ADC1_INP18 ADC2_INP18 DAC1_OUT1 |
| P6 | PA5 | IO | TT | Yes | SPI1_SCK SPI4_SCK I2S1_CK I2S4_CK ESC_LED_STATE_RUN ATIM2_CH1N GTIMA1_CH1 GTIMA1_ETR LCD_R4 FEMC_D9/FEMC_DA9 SDRAM_D9 SDRAM_DQM0 | ADC1_INN18 ADC1_INP19 ADC2_INN18 ADC2_INP19 DAC1_OUT2 |
| R7 | PA6 | IO | TT | Yes | SPI1_MISO SPI4_MISO I2S1_SDI I2S4_SDI xSPI2_IO3 ESC_P1_LINK ATIM1_BKIN1 ATIM2_BKIN1 ATIM3_CH1 GTIMA2_CH1 DVP1_PIXCLK LCD_G2 | ADC1_INP3 ADC2_INP3 |
| N6 | PA7 | IO | TT | Yes | SPI1_MOSI SPI4_MOSI I2S1_SDO I2S4_SDO xSPI2_IO2 ETH1_MII_RX_DV/ETH1_RMII_ CRS_DV/ETH1_GMII_RX_DV ESC_P0_MII_RX_DV | ADC1_INN3 ADC1_INP7 ADC2_INN3 ADC2_INP7 |

| | | | | | | |
|----|-----|----|----|-----|---|---|
| | | | | | ATIM1_CH1N ATIM2_CH1N ATIM4_CH1 GTIMA2_CH2 LCD_VSYNC SDRAM_NWE | |
| R6 | PC4 | IO | TT | Yes | I2S1_MCK ETH1_MII_RXD0/ETH1_RMII_R XD0/ETH1_GMII_RXD0 ESC_P0_MII_RXD0 SHRTIM2_EEV LCD_R7 SDMMC2_CKIN FEMC_A22 SDRAM_NCE0 DSMU_CKIN2 | ADC1_INP4 ADC2_INP4 COMP1_INM |
| M7 | PC5 | IO | TT | Yes | ETH1_MII_RXD1/ETH1_RMII_R XD1/ ETH1_GMII_RXD1 ESC_P0_MII_RXD1 SHRTIM2_FLT LCD_DE SDMMC2_SEL SDRAM_CKE0 DSMU_DATIN2 FEMC_A1 SDRAM_NCAS | ADC1_INN4 ADC1_INP8 ADC2_INN4 ADC2_INP8 COMP1_OUT |
| K4 | VDD | S | - | - | - | - |
| F9 | VSS | S | - | - | - | - |
| R8 | PB0 | IO | TT | Yes | xSPI2_IO1 ETH1_MII_RXD2/ETH1_GMII_R XD2 ESC_P0_MII_RXD2 ATIM1_CH2N ATIM2_CH2N GTIMA2_CH3 LCD_G1 LCD_R3 UART9_CTS DSMU_CKOUT | ADC1_INN5 ADC1_INP9 ADC2_INN5 ADC2_INP9 COMP1_INP |
| M8 | PB1 | IO | TT | Yes | SPI3_MISO xSPI2_IO0 ETH1_MII_RXD3/ETH1_GMII_R XD3 ESC_P0_MII_RXD3 ATIM1_CH3N ATIM2_CH3N GTIMA2_CH4 DVP1_MCLK LCD_G0 LCD_R6 DSMU_DATIN1 | ADC1_INP5 ADC2_INP5 COMP1_INM |
| P7 | PB2 | IO | TT | Yes | RTC_OUT2 SPI3_MOSI I2S3_SDO xSPI2_CLK/xSPI2_CLKIN ETH1_MII_TX_ER/ETH1_GMII_ TX_ER ESC_LED_ERR ATIM1_CH4N ATIM2_CH4N GTIMA5_ETR | COMP1_INP |

| | | | | | | |
|-----|------|----|----|-----|---|-------------------------------------|
| | | | | | DVP1_HSYNC DVP2_D12 DSMU_CKIN1 | |
| N7 | PF11 | IO | TT | Yes | SPI5_MOSI ETH2_MII_TX_EN/ETH2_RMII_TX_EN ESC_P1_MII_TX_EN GTIMA6_CH1 DVP1_D12 SDRAM_NRAS I2C6_SDA SDRAM_NRAS | ADC1_INP2 |
| P11 | PF12 | IO | TT | Yes | xSPI2_DQS ETH2_MII_TXD0/ETH2_RMII_TXD0 ESC_P1_MII_TXD0 GTIMA6_CH2 DVP2_D6 FEMC_A6 SDRAM_A6 FDCAN6_TX I2C6_SCL | ADC1_INN2 ADC1_INP6 |
| F10 | VSS | S | - | - | - | - |
| L12 | VDD | S | - | - | - | - |
| N11 | PF13 | IO | TT | Yes | ETH2_MII_TXD1/ETH2_RMII_TXD1 ESC_P1_MII_TXD1 SHRTIM2_FLT GTIMA6_CH3 DVP2_D7 FEMC_A7 SDRAM_A7 USART7_CK FDCAN6_RX I2C4_SMBA I2C6_SMBA DSMU_DATIN6 SDRAM_NCE0 | ADC2_INP2 COMP3_OUT |
| R10 | PF14 | IO | TT | Yes | ETH2_MII_TXD2 ESC_P1_MII_TXD2 SHRTIM2_CHF1 GTIMA6_CH4 DVP2_D8 FEMC_A8 SDRAM_A8 USART7_RX FDCAN3_RX I2C4_SCL DSMU_CKIN6 | ADC2_INN2 ADC2_INP6 COMP3_INM |
| N10 | PF15 | IO | TT | Yes | ETH2_MII_TXD3 ESC_P1_MII_TXD3 SHRTIM2_CHF2 LPTIM4_ETR DVP2_D9 FEMC_A9 SDRAM_A9 USART7_TX FDCAN3_TX I2C4_SDA SDRAM_BA0 | COMP3_INP |
| P8 | PG0 | IO | TT | Yes | xSPI2_IO4 xSPI2_NCS2 | - |

| | | | | | | |
|-----|------|----|----|-----|--|-----------|
| | | | | | ETH2_MII_TX_CLK ESC_P1_MII_TX_CLK SHRTIM1_EEV ATIM4_BKIN1 LPTIM4_IN1 DVP2_D10 FEMC_A10 SDRAM_A10 UART13_RX SDRAM_BA1 | |
| F12 | VSS | S | - | - | - | - |
| M5 | VDD | S | - | - | - | - |
| N9 | PG1 | IO | TT | Yes | xSPI2_IO5 xSPI2_NCS3 ETH2_MII_TX_ER SHRTIM2_FLT GTIMB1_ETR LPTIM4_IN2 DVP2_D11 FEMC_A11 SDRAM_A11 UART13_TX SDRAM_A10 | - |
| P9 | PE7 | IO | TT | Yes | xSPI2_NCS2 ETH2_PHY_INTN ATIM1_ETR FEMC_D4/FEMC_DA4 SDRAM_D4 UART11_RX I2C7_SDA DSMU_DATIN2 | COMP2_INM |
| N8 | PE8 | IO | TT | Yes | ESC_EEPROM_CLK ATIM1_CHIN SDMMC1_LEDCTRL FEMC_D5/FEMC_DA5 SDRAM_D5 UART11_TX FDCAN5_TX I2C7_SCL DSMU_CKIN2 SDRAM_A0 | COMP2_OUT |
| R11 | PE9 | IO | TT | Yes | ESC_EEPROM_DATA ATIM1_CH1 SDMMC2_LEDCTRL FEMC_D6/FEMC_DA6 SDRAM_D6 UART11_DE/UART11_RTS FDCAN5_RX I2C7_SMBA DSMU_CKOUT SDRAM_A1 | COMP2_INP |
| G6 | VSS | S | - | - | - | - |
| M9 | VDD | S | - | - | - | - |
| R9 | PE10 | IO | TT | Yes | ESC_LED_STATE_RUN ATIM1_CH2N FEMC_D7/FEMC_DA7 SDRAM_D7 UART11_CTS DSMU_DATIN4 SDRAM_A2 | COMP2_INM |
| R12 | PE11 | IO | TT | Yes | SPI6_NSS ESC_P0_LINK | COMP2_INP |

| | | | | | | |
|-----|------|----|----|-----|--|-----------|
| | | | | | ATIM1_CH2 LCD_G3 FEMC_D8/FEMC_DA8 SDRAM_D8 DSMU_CKIN4 SDRAM_A3 | |
| P12 | PE12 | IO | TT | Yes | SPI6_SCK ETH1_GMII_RXD4 ESC_MDC ATIM1_CH3N LCD_B4 FEMC_D9/FEMC_DA9 SDRAM_D9 UART13_RX DSMU_DATIN5 | COMP1_OUT |
| P13 | PE13 | IO | TT | Yes | SPI6_MISO ETH1_GMII_RXD5 ESC_MDIO ATIM1_CH3 LCD_DE FEMC_D10/FEMC_DA10 SDRAM_D10 UART13_TX FDCAN6_TX I2C6_SDA DSMU_CKIN5 | COMP2_OUT |
| G7 | VSS | S | - | - | - | - |
| M12 | PE14 | IO | TT | Yes | SPI6_MOSI ETH1_GMII_RXD6 SHRTIM2_EEV ATIM1_CH4 LCD_CLK FEMC_D11/FEMC_DA11 SDRAM_D11 USART6_CK UART13_CTS FDCAN6_RX I2C6_SCL | - |
| P14 | PE15 | IO | TT | Yes | ETH1_GMII_RXD7 ESC_LED_RUN ATIM1_BKIN1 LCD_R7 FEMC_D12/FEMC_DA12 SDRAM_D12 USART5_CK UART13_DE/UART13_RTS I2C6_SMBA | - |
| N12 | PB10 | IO | TT | Yes | SPI2_SCK I2S2_CK ETH1_MII_RX_ER/ETH1_GMII_ RX_ER ESC_P0_MII_RX_ER SHRTIM1_SCOUT GTIMA1_CH3 LPTIM2_IN1 LCD_G4 USART3_TX I2C2_SCL DSMU_DATIN7 FEMC_D13/FEMC_DA13 | - |
| P10 | PB11 | IO | TT | Yes | ETH1_MII_TX_EN/ETH1_RMII_ TX_EN/ETH1_GMII_TX_EN | - |

| | | | | | | |
|-----|------|----|----|-----|---|-----------|
| | | | | | ESC_P0_MII_TX_EN SHRTIM1_SCIN GTIMA1_CH4 LPTIM2_ETR LCD_G5 USART3_RX I2C2_SDA DSMU_CKIN7 FEMC_D15/FEMC_DA15 | |
| R13 | VCAP | S | - | - | - | - |
| M10 | VSS | S | - | - | - | - |
| R14 | NC | S | - | - | - | - |
| P15 | PH6 | IO | TT | Yes | SPI5_SCK ETH1_MII_RXD2/ETH1_GMII_RXD2 ESC_P0_MII_RXD2 ATIM1_CH4N GTIMA7_CH1 LPTIM5_IN1 DVP1_D8 FEMC_BAA SDRAM_NCE1 UART14_RX FDCAN7_TX I2C2_SMBA SDRAM_A4 | COMP4_INM |
| M11 | PH7 | IO | TT | Yes | SPI5_MISO ETH1_MII_RXD3/ETH1_GMII_RXD3 ESC_P0_MII_RXD3 SHRTIM2_EEV ATIM3_BKIN1 LPTIM5_IN2 DVP1_D9 FEMC_CRE SDRAM_CKE1 UART14_TX FDCAN7_RX I2C3_SCL SDRAM_A5 | COMP4_INP |
| N13 | PH8 | IO | TT | Yes | ETH1_GMII_RXD4 SHRTIM2_EEV ATIM3_CH1 GTIMA4_ETR DVP1_HSYNC LCD_R2 FEMC_D16 SDRAM_D16 UART10_DE/UART10_RTS UART14_DE/UART14_RTS FDCAN2_RX I2C3_SDA SDRAM_A6 | COMP4_OUT |
| G9 | VSS | S | - | - | - | - |
| M14 | PH9 | IO | TT | Yes | ETH1_GMII_RXD5 ATIM3_CH1N GTIMA7_CH2 DVP1_D0 LCD_R3 FEMC_D17 SDRAM_D17 UART10_CTS | COMP4_INM |

| | | | | | | |
|-----|------|----|----|-----|---|-----------|
| | | | | | UART14_CTS FDCAN2_TX I2C3_SMBA SDRAM_A7 | |
| N14 | PH10 | IO | TT | Yes | ETH1_GMII_RXD6 ESC_P0_MII_RXD2 SHRTIM2_EEV ATIM3_CH2 GTIMA4_CH1 DVP1_D1 LCD_R4 FEMC_D18 SDRAM_D18 I2C4_SMBA SDRAM_A8 | COMP4_INM |
| M13 | PH11 | IO | TT | Yes | ETH1_GMII_RXD7 ESC_P0_MII_RXD3 SHRTIM2_EEV ATIM3_CH2N GTIMA4_CH2 DVP1_D2 LCD_R5 FEMC_D19 SDRAM_D19 UART10_RX I2C4_SCL SDRAM_A9 | - |
| N15 | PH12 | IO | TT | Yes | SPI7_NSS ETH2_MII_RX_DV/ETH2_RMII_ CRS_DV ESC_P1_MII_RX_DV SHRTIM2_EEV ATIM3_ETR GTIMA4_CH3 DVP1_D3 LCD_R6 FEMC_D20 SDRAM_D20 UART10_TX I2C4_SDA SDRAM_A11 | COMP4_OUT |
| G10 | VSS | S | - | - | - | - |
| M15 | PB12 | IO | TT | No | SPI2_NSS/I2S2_WS ETH1_MII_TXD0/ETH1_RMII_T XD0/ETH1_GMII_TXD0 ESC_P0_MII_TXD0 ATIM1_BKIN1 LPTIM2_IN2 DVP2_D14 USART3_CK UART10_RX FDCAN2_RX USB2_ID I2C2_SMBA DSMU_DATIN1 | - |
| L15 | PB13 | IO | TT | No | SPI2_SCK I2S2_CK ETH1_MII_TXD1/ETH1_RMII_T XD1/ETH1_GMII_TXD1 ESC_P0_MII_TXD1 ATIM1_CH1N LPTIM2_OUT | - |

| | | | | | | |
|-----|------|----|----|-----|---|---|
| | | | | | DVP1_D2 SDMMC1_D0 USART3_CTS/USART3_NSS UART10_TX FDCAN2_TX USB2_VBUS DSMU_CKIN1 | |
| K15 | PB14 | IO | TT | No | SPI2_MISO I2S2_SDI ATIM1_CH2N ATIM2_CH2N GTIMA7_CH1 LCD_CLK SDMMC2_D0 FEMC_D10/FEMC_DA10 SDRAM_D10 USART1_TX USART3_DE/USART3_RTS UART9_DE/UART9_RTS USB2_DM DSMU_DATIN2 | - |
| K14 | PB15 | IO | TT | No | RTC_REFIN SPI2_MOSI I2S2_SDO ATIM1_CH3N ATIM2_CH3N GTIMA7_CH2 LCD_G7 SDMMC2_D1 FEMC_D11/FEMC_DA11 SDRAM_D11 USART1_RX UART9_CTS USB2_DP DSMU_CKIN2 | - |
| L14 | PD8 | IO | TT | Yes | ESC_LED_ERR SHRTIM1_EEV SHRTIM2_SCIN ATIM3_CH3 DVP2_HSYNC FEMC_D13/FEMC_DA13 SDRAM_D13 USART3_TX I2C7_SDA DSMU_CKIN3 | - |
| K13 | PD9 | IO | TT | Yes | ESC_SYNC0 SHRTIM1_EEV SHRTIM2_SCOUT ATIM3_CH3N DVP2_VSYNC FEMC_D14/FEMC_DA14 SDRAM_D14 USART3_RX I2C7_SCL DSMU_DATIN3 | - |
| L13 | PD10 | IO | TT | Yes | ETH1_CLK125 ETH2_PPS_OUT ATIM1_CH4N LPTIM2_OUT LCD_B3 FEMC_D15/FEMC_DA15 SDRAM_D15 | - |

| | | | | | | |
|-----|------|----|----|-----|---|---|
| | | | | | USART3_CK I2C7_SMBA DSMU_CKOUT | |
| H6 | VSS | S | - | - | - | - |
| J13 | PD11 | IO | TT | Yes | ESC_LATCH0 SHRTIM2_EEV GTIMA3_ETR LPTIM2_IN2 DVP2_D15 FEMC_A16/FEMC_CLE USART3_CTS/USART3_NSS I2C4_SMBA | - |
| J15 | PD12 | IO | TT | Yes | ESC_LINK_ACT0 GTIMA3_CH1 LPTIM1_IN1 LPTIM2_IN1 DVP1_D12 FEMC_A17/FEMC_ALE USART3_DE/USART3_RTS UART12_TX UART13_CTS FDCAN3_RX I2C4_SCL | - |
| H15 | PD13 | IO | TT | Yes | ESC_RESET_OUT GTIMA3_CH2 LPTIM1_OUT DVP1_D13 FEMC_A18 UART12_RX UART13_DE/UART13_RTS FDCAN3_TX I2C4_SDA I2C8_SMBA | - |
| R1 | VSS | S | - | - | - | - |
| H14 | PD14 | IO | TT | Yes | ETH1_PPS_OUT ATIM3_CH4 GTIMA3_CH3 SDMMC1_D4 FEMC_D0/FEMC_DA0 SDRAM_D0 UART12_CTS UART13_RX I2C8_SDA SDRAM_CKE0 | - |
| J12 | PD15 | IO | TT | Yes | ETH1_PHY_INTN ETH2_PHY_INTN SHRTIM2_FLT ATIM3_CH4N GTIMA3_CH4 SDMMC1_D5 FEMC_D1/FEMC_DA1 SDRAM_D1 UART12_DE/UART12_RTS UART13_TX I2C8_SCL | - |
| D6 | VSS | S | - | - | - | - |
| R15 | VSS | S | - | - | - | - |
| G15 | PG2 | IO | TT | Yes | ETH2_MII_RXD0/ETH2_RMII_RXD0 ESC_P1_MII_RXD0 SHRTIM2_SCIN ATIM2_BKIN1 | - |

| | | | | | | |
|-----|-----|----|----|-----|---|---|
| | | | | | GTIMA6_ETR DVP2_D12 FEMC_A12 SDRAM_A12 USART7_CTS/USART7_NSS FDCAN8_TX SDRAM_DQM1 | |
| H13 | PG3 | IO | FT | Yes | ETH2_MII_RXD1/ETH2_RMII_RXD1 ESC_P1_MII_RXD1 SHRTIM2_SCOUT ATIM2_BKIN2 GTIMA5_ETR DVP2_D13 FEMC_A13 USART7_DE/USART7_RTS FDCAN8_RX | - |
| H10 | VSS | S | - | - | - | - |
| G14 | PG4 | IO | TT | Yes | ETH2_MII_RXD2 ESC_P1_MII_RXD2 SHRTIM1_CHF1 ATIM1_BKIN2 DVP2_D14 SDMMC2_CKIN SDMMC2_D4 FEMC_A14 SDRAM_BA0 USART6_CTS/USART6_NSS I2C1_SDA I2C8_SDA | - |
| F15 | PG5 | IO | TT | Yes | ETH2_MII_RXD3 ESC_P1_MII_RXD3 SHRTIM1_CHF2 ATIM1_ETR DVP2_D15 SDMMC2_CDIR SDMMC2_D5 FEMC_A15 SDRAM_BA1 USART6_DE/USART6_RTS I2C1_SCL I2C8_SCL | - |
| F14 | PG6 | IO | TT | Yes | ETH2_MII_RX_ER ESC_P1_MII_RX_ER SHRTIM1_CHE1 GTIMB3_BRK DVP1_D12 LCD_R7 FEMC_NE3 I2C1_SMBA I2C8_SMBA | - |
| G13 | PG7 | IO | TT | Yes | xSPI2_DQS ETH1_PHY_INTN SHRTIM1_CHE2 DVP1_D13 LCD_CLK FEMC_INT/FEMC_BUSY USART4_CK FDCAN7_TX | - |
| G12 | PG8 | IO | TT | Yes | SPI4_NSS I2S4_WS ETH1_PPS_OUT | - |

| | | | | | | |
|-----|-----------|----|----|-----|---|---|
| | | | | | ESC_P1_LINK SHRTIM2_EEV ATIM2_ETR LCD_G7 SDRAM_CLK USART4_DE/USART4_RTS FDCAN7_RX SDRAM_CLK | |
| J6 | VSS | S | - | - | - | - |
| E15 | NC | S | - | - | - | - |
| F13 | VDD33_USB | S | - | - | - | - |
| E14 | PC6 | IO | FT | Yes | I2S2_MCK ESC_MDIO ESC_RESET_OUT SHRTIM1_CHA1 ATIM2_CH1 GTIMA2_CH1 DVP1_D0 LCD_HSYNC SDMMC1_D0DIR SDMMC1_D6 SDMMC2_D6 FEMC_NWAIT USART4_TX DSMU_CKIN3 | - |
| D15 | PC7 | IO | FT | Yes | TRGIO I2S3_MCK ESC_MDC SHRTIM1_CHA2 ATIM2_CH2 GTIMA2_CH2 DVP1_D1 LCD_G6 SDMMC1_D123DIR SDMMC1_D7 SDMMC2_D7 FEMC_NE1/FEMC_NCE2 USART4_RX DSMU_DATIN3 | - |
| D14 | PC8 | IO | FT | Yes | TRACED1 ESC_IRQ SHRTIM1_CHB1 ATIM2_CH3 GTIMA2_CH3 DVP1_D2 SDMMC1_D0 FEMC_NCE1/FEMC_NE2 FEMC_INT/FEMC_BUSY USART4_CK UART10_DE/UART10_RTS | - |
| E13 | PC9 | IO | TT | Yes | MCO2 I2S1_CKIN I2S2_CKIN I2S3_CKIN I2S4_CKIN ATIM2_CH4 GTIMA2_CH4 DVP1_D3 LCD_B2 LCD_G3 SDMMC1_D1 | - |

| | | | | | | |
|-----|---------|----|----|-----|--|---|
| | | | | | UART10_CTS I2C3_SDA I2C5_SDA | |
| J7 | VSS | S | - | - | - | - |
| B14 | PA8 | IO | FT | No | RCC_MCO1 ETH2_MII_RX_CLK/ETH2_RMII_REF_CLK ESC_P1_MII_RX_CLK SHRTIM1_CHB2 ATIM1_CH1 ATIM2_BKIN2 LCD_B3 LCD_R6 USART1_CK UART11_RX USB1_SOF I2C3_SCL I2C5_SCL | - |
| D13 | PA9 | IO | TT | No | SPI2_SCK I2S2_CK ETH1_MII_TX_ER/ETH1_GMII_TX_ER ESC_SYNC0 SHRTIM1_CHC1 ATIM1_CH2 DVP1_D0 LCD_R5 USART1_TX LPUART1_TX USB1_VBUS I2C3_SMBA I2C5_SMBA | - |
| C14 | PA10 | IO | TT | No | ESC_P1_LINK SHRTIM1_CHC2 ATIM1_CH3 DVP1_D1 LCD_B1 LCD_B4 USART1_RX LPUART1_RX USB1_ID | - |
| C15 | USB1_DM | IO | TT | No | USB1_DM | - |
| B15 | USB1_DP | IO | TT | No | USB1_DP | - |
| B13 | PA13 | IO | FT | Yes | JTMS-SWDIO | - |
| A14 | VCAP | S | - | - | - | - |
| M6 | VSS | S | - | - | - | - |
| A13 | NC | S | - | - | - | - |
| C13 | PH13 | IO | TT | Yes | SPI7_NSS ETH2_MII_TX_EN/ETH2_RMII_TX_EN ESC_P1_MII_TX_EN ATIM2_CH1N LCD_G2 FEMC_D21 SDRAM_D21 UART9_TX FDCAN1_TX I2C9_SMBA | - |
| B12 | PH14 | IO | TT | Yes | SPI7_MISO ETH2_MII_TXD0/ETH2_RMII_T | - |

| | | | | | | |
|-----|------|----|----|-----|---|---|
| | | | | | XD0 ESC_P1_MII_TXD0 ATIM2_CH2N DVP1_D4 LCD_G3 FEMC_D22 SDRAM_D22 USART6_RX UART9_RX FDCAN1_RX I2C9_SDA | |
| D12 | PH15 | IO | TT | Yes | SPI7_MOSI ETH2_MII_TXD1/ETH2_RMII_T XD1 ESC_P1_MII_TXD1 ATIM2_CH3N DVP1_D11 LCD_G4 FEMC_D23 SDRAM_D23 USART6_TX I2C9_SCL | - |
| J9 | VSS | S | - | - | - | - |
| J10 | VSS | S | - | - | - | - |
| A12 | PA14 | IO | FT | Yes | JTCK-SWCLK | - |
| A11 | PA15 | IO | FT | Yes | JTDI SPI1_NSS SPI3_NSS SPI4_NSS I2S1_WS I2S3_WS I2S4_WS SHRTIM1_FLT GTIMA1_CH1 GTIMA1_ETR LCD_B6 LCD_R3 UART9_DE/UART9_RTS UART11_TX | - |
| C12 | PC10 | IO | TT | Yes | SPI3_SCK I2S3_CK ESC_P0_MII_TXD2 SHRTIM1_EEV DVP1_D8 LCD_R2 LCD_B1 SDMMC1_D2 USART3_TX UART9_TX I2C5_SDA DSMU_CKIN5 | - |
| C11 | PC11 | IO | TT | Yes | SPI3_MISO I2S3_SDI ESC_P0_MII_TXD3 SHRTIM1_FLT DVP1_D4 LCD_B4 SDMMC1_D3 USART3_RX UART9_RX I2C5_SCL DSMU_DATIN5 | - |

| | | | | | | |
|-----|------|----|----|-----|---|---|
| B11 | PC12 | IO | TT | Yes | TRACED3 SPI3_MOSI SPI4_SCK I2S3_SDO I2S4_CK ESC_LINK_ACT0 SHRTIM1_EEV GTIMB1_CH1P DVP1_D9 LCD_R6 SDMMC1_CK FEMC_D6/FEMC_DA6 SDRAM_D6 USART3_CK UART10_TX I2C5_SMBA | - |
| J14 | VSS | S | - | - | - | - |
| C10 | PD0 | IO | TT | Yes | ESC_LED_ERR SHRTIM2_EEV GTIMB2_CH1N LCD_B1 SDMMC1_WP FEMC_D2/FEMC_DA2 SDRAM_D2 UART9_RX UART13_CTS FDCAN1_RX DSMU_CKIN6 SDRAM_D11 | - |
| A10 | PD1 | IO | TT | Yes | ESC_RESET_OUT SHRTIM2_FLT GTIMB2_CH1P SDMMC1_CD FEMC_D3/FEMC_DA3 SDRAM_D3 UART9_TX FDCAN1_TX I2C1_SMBA DSMU_DATIN6 SDRAM_D12 | - |
| B10 | PD2 | IO | TT | Yes | TRACED2 GTIMA2_ETR GTIMB1_BRK GTIMB2_CH2 DVP1_D11 LCD_B2 LCD_B7 SDMMC1_CMD FEMC_D7/FEMC_DA7 SDRAM_D7 UART10_RX LPUART2_CTS SDRAM_D13 | - |
| A9 | PD3 | IO | FT | Yes | SPI2_SCK I2S2_CK ESC_IRQ GTIMB2_CH3 DVP1_D5 LCD_G7 SDMMC1_RST FEMC_CLK USART2_CTS/USART2_NSS | - |

| | | | | | | |
|----|------|----|----|-----|--|---|
| | | | | | LPUART2_DE/LPUART2_RTS DSMU_CKOUT | |
| C9 | PD4 | IO | TT | Yes | SPI3_NSS SHRTIM1_FLT GTIMB2_CH4 DVP1_D14 SDMMC2_WP FEMC_NOE USART2_DE/USART2_RTS LPUART2_TX I2C1_SCL | - |
| B9 | PD5 | IO | TT | Yes | SPI3_MISO ESC_SYNC1 SHRTIM1_EEV GTIMB2_ETR DVP1_D15 SDMMC2_CD FEMC_NWE USART2_TX LPUART2_RX I2C1_SDA | - |
| K2 | VSS | S | - | - | - | - |
| D9 | PD6 | IO | TT | Yes | SPI3_MOSI I2S3_SDO ESC_LATCH1 DVP1_D10 LCD_B2 SDMMC2_CK FEMC_NWAIT USART2_RX DSMU_CKIN4 DSMU_DATIN1 | - |
| B8 | PD7 | IO | TT | Yes | SPI1_MOSI SPI3_SCK I2S1_SDO ESC_LINK_ACT1 ATIM4_BKIN1 SDMMC2_CMD FEMC_NE1/FEMC_NCE2 USART2_CK DSMU_CKIN1 DSMU_DATIN4 | - |
| K6 | VSS | S | - | - | - | - |
| A8 | PG9 | IO | TT | Yes | SPI1_MISO I2S1_SDI ETH2_MII_RXD0/ETH2_RMII_R XD0 ESC_P1_MII_RXD0 SHRTIM1_FLT DVP1_VSYNC SDMMC2_D0 FEMC_NCE1/FEMC_NE2 USART4_RX FDCAN3_TX | - |
| C8 | PG10 | IO | TT | Yes | SPI1_NSS I2S1_WS xSPI2_IO6 xSPI2_NCS4 ETH2_MII_RXD1/ETH2_RMII_R XD1 ESC_P1_MII_RXD1 SHRTIM1_FLT | - |

| | | | | | | |
|----|------|----|----|-----|--|---|
| | | | | | DVP1_D2 LCD_B2 LCD_G3 SDMMC2_D1 FEMC_NE3 FDCAN3_RX | |
| A7 | PG11 | IO | TT | Yes | SPI1_SCK I2S1_CK xSPI2_IO7 xSPI2_NCSIN ETH1_MII_TX_EN/ETH1_RMII_TX_EN/ETH1_GMII_TX_EN ESC_P0_MII_TX_EN SHRTIM1_EEV LPTIM1_IN2 DVP1_D3 LCD_B3 SDMMC2_D2 USART5_RX | - |
| D8 | PG12 | IO | TT | Yes | SPI4_MISO I2S4_SDI xSPI2_NCS1 ETH1_MII_TXD1/ETH1_RMII_TXD1/ETH1_GMII_TXD1 ESC_P0_MII_TXD1 SHRTIM1_EEV GTIMA5_CH1 LPTIM1_IN1 DVP2_MCLK LCD_B1 LCD_B4 SDMMC2_D3 FEMC_NE4 USART4_DE/USART4_RTS USART5_TX | - |
| B7 | PG13 | IO | TT | Yes | TRACED0 SPI4_SCK I2S4_CK ETH1_MII_TXD0/ETH1_RMII_TXD0/ETH1_GMII_TXD0 ESC_P0_MII_TXD0 SHRTIM1_EEV GTIMA5_CH2 LPTIM1_OUT LCD_R0 SDMMC2_D0DIR SDMMC2_D6 FEMC_A24 USART4_CTS/USART4_NSS USART5_CTS/USART5_NSS | - |
| C7 | PG14 | IO | TT | Yes | TRACED1 SPI4_MOSI I2S4_SDO ETH1_MII_TXD1/ETH1_RMII_TXD1/ETH1_GMII_TXD1 ESC_P0_MII_TXD1 GTIMA5_CH3 LPTIM1_ETR LCD_B0 SDMMC2_D123DIR SDMMC2_D7 FEMC_A25 | - |

| | | | | | USART4_TX USART5_DE/USART5_RTS | |
|----|------|----|----|-----|---|---|
| K7 | VSS | S | - | - | - | - |
| K8 | VSS | S | - | - | - | - |
| D7 | PG15 | IO | TT | Yes | xSPI2_DQS ETH1_PHY_INTN ESC_LINK_ACT0 ESC_LED_ERR SHRTIM2_EEV DVP1_D13 SDMMC2_RST SDRAM_NCAS USART4_CTS/USART4_NSS USART5_CK SDRAM_D14 | - |
| A6 | PB3 | IO | FT | Yes | TRACESWO/JTDO SPI1_SCK SPI3_SCK SPI4_SCK I2S1_CK I2S3_CK I2S4_CK SHRTIM1_FLT GTIMA1_CH2 GTIMA6_ETR SDMMC2_D2 UART11_RX | - |
| B6 | PB4 | IO | FT | Yes | JTRST SPI1_MISO SPI2_NSS SPI3_MISO SPI4_MISO I2S1_SDI I2S2_WS I2S3_SDI I2S4_SDI ETH1_PHY_INTN SHRTIM1_EEV GTIMA2_CH1 GTIMB2_BRK SDMMC2_D3 UART11_TX | - |
| C6 | PB5 | IO | TT | Yes | SPI1_MOSI/I2S1_SDO SPI3_MOSI/I2S3_SDO SPI4_MOSI/I2S4_SDO ETH1_PPS_OUT SHRTIM1_EEV GTIMA2_CH2 GTIMB3_BRK DVP1_D10 LCD_B5 SDRAM_CKE1 UART10_RX FDCAN2_RX I2C1_SMBA I2C4_SMBA | - |
| K9 | VSS | S | - | - | - | - |
| A5 | PB6 | IO | TT | Yes | SHRTIM1_EEV GTIMA2_CH3 GTIMA3_CH1 GTIMB2_CH1N DVP1_D5 | - |

| | | | | | | |
|----|-------|----|------|-----|--|---|
| | | | | | SDMMC1_D6 SDRAM_NCE1 USART1_TX UART10_TX LPUART1_TX FDCAN2_TX I2C1_SCL I2C4_SCL DSMU_DATIN5 | |
| B5 | PB7 | IO | TT | Yes | ETH1_MII_TXD2/ETH1_GMII_T XD2 ESC_P0_MII_TXD2 SHRTIM1_EEV GTIMA2_CH4 GTIMA3_CH2 GTIMB3_CH1N DVP1_VSYNC SDMMC1_D7 FEMC_NL/FEMC_NADV USART1_RX LPUART1_RX I2C1_SDA I2C4_SDA DSMU_CKIN5 | - |
| C5 | BOOT0 | I | BOOT | Yes | BOOT0 | - |
| A2 | PB8 | IO | TT | Yes | ETH1_MII_TXD3/ETH1_GMII_T XD3 GTIMA2_ETR GTIMA3_CH3 GTIMB2_CH1P DVP1_D6 LCD_B6 SDMMC1_CKIN SDMMC1_D4 SDMMC2_D4 UART9_RX FDCAN1_RX I2C1_SCL I2C4_SCL DSMU_CKIN7 | - |
| B3 | PB9 | IO | FT | Yes | SPI2_NSS/I2S2_WS GTIMA3_CH4 GTIMB3_CH1P DVP1_D7 LCD_B7 SDMMC1_CDIN SDMMC1_D5 SDMMC2_D5 UART9_TX FDCAN1_TX I2C1_SDA I2C4_SDA I2C4_SMBA DSMU_DATIN7 | - |
| B4 | PE0 | IO | TT | Yes | ESC_P0_LINK SHRTIM1_SCIN GTIMA3_ETR GTIMB1_CH3 LPTIM1_ETR LPTIM2_ETR DVP1_D2 LCD_R0 | - |

| | | | | | | |
|--|------|----|----|-----|---|---|
| | | | | | FEMC_NBL0 SDRAM_DQM0 UART12_RX | |
| C4 | PE1 | IO | TT | Yes | ESC_RESET_IN SHRTIM1_SCOUT GTIMB1_CH4 LPTIM1_IN2 DVP1_D3 LCD_R6 FEMC_NBL1 SDRAM_DQM1 UART12_TX SDRAM_D15 | - |
| A4 | VCAP | S | - | - | - | - |
| K10 | VSS | S | - | - | - | - |
| D4 | NC | S | - | - | - | - |
| A3 | NC | S | - | - | - | - |
| K12/ G8/ H7/ H8/ H9/ J8 | VSS | S | - | - | - | - |

3.3 GPIO Multiplexing Function

3.3.1 GPIOA Multiplexing Function

Table 3-2 GPIOA Multiplexing Function

| Port | AF0 | AF1 | AF2 | AF3 | AF4 | AF5 | AF6 | AF7 | AF8 | AF9 | AF10 | AF11 | AF12 | AF13 | AF14 | AF15 |
|------|-----------------------------------|------------------|--|---|------------|--------------|-------------|------------|----------------------|--------------|-----------------------|--------------------|------------------|------------------|----------|------------|
| PA0 | ETH1_MII_CRS/ETH1_GMII_CRS | SDMMC2_CMD | FEMC_A19 | SPI4_NSS | I2S4_WS | ATIM2_ETR | GTIMA1_CH1 | GTIMA1_ETR | GTIMA4_CH1 | GTIMB1_BRK | USART2_CTS/USART2_NSS | UART9_TX | ESC_P0_MII_RX_DV | - | EVENTOUT | - |
| PA1 | - | - | ETH1_MII_RX_CLK/ETH1_RMII_REF_CLK/ETH1_GMII_RX_CLK | LCD_R2 | GTIMA1_CH2 | GTIMA4_CH2 | GTIMB1_CHIN | LPTIM3_OUT | USART2_DE/USART2_RTS | UART9_RX | ESC_P0_MII_RX_CLK | - | - | - | EVENTOUT | - |
| PA2 | - | ETH1_MDIO | LCD_R1 | GTIMA1_CH3 | GTIMA4_CH3 | GTIMB1_CHIP | LPTIM4_OUT | USART2_TX | ESC_MDIO | ESC_P1_LI_NK | - | - | - | - | EVENTOUT | - |
| PA3 | - | - | ETH1_MII_COL/ETH1_GMII_COL | FEMC_A10 | LCD_B2 | LCD_B5 | I2S4_MCK | GTIMA1_CH4 | GTIMA4_CH4 | GTIMB1_CH2 | LPTIM5_OUT | USART2_RX | - | - | EVENTOUT | - |
| PA4 | SDRAM_D8 | FEMC_D8/FEMC_DA8 | LCD_VSYN_C | DVP1_HSYN_C | SPI1_NSS | SPI3_NSS | SPI4_NSS | I2S1_WS | I2S3_WS | I2S4_WS | GTIMA4_ETR | USART2_CK | USB2_SOF | ESC_LED_RUN | EVENTOUT | - |
| PA5 | SDRAM_D9 | SDRAM_DQM0 | FEMC_D9/FEMC_DA9 | LCD_R4 | SPI1_SCK | SPI4_SCK | I2S1_CK | I2S4_CK | ATIM2_CHIN | GTIMA1_CH1 | GTIMA1_ETR | ESC_LED_STATE_RUN | - | - | EVENTOUT | - |
| PA6 | - | xSPI2_IO3 | LCD_G2 | DVP1_PIXCLK | SPI1_MISO | SPI4_MISO | I2S1_SDI | I2S4_SDI | ATIM1_BKIN1 | ATIM2_BKIN1 | ATIM3_CH1 | GTIMA2_CH1 | ESC_P1_LI_NK | - | EVENTOUT | - |
| PA7 | SDRAM_NWE | - | xSPI2_IO2 | ETH1_MII_RX_DV/ETH1_RMII_CRS_DV/ETH1_GMII_RX_DV | LCD_VSYN_C | SPI1_MOSI | SPI4_MOSI | I2S1_SDO | I2S4_SDO | ATIM1_CHIN | ATIM2_CHIN | ATIM4_CH1 | GTIMA2_CH2 | ESC_P0_MII_RX_DV | EVENTOUT | - |
| PA8 | ETH2_MII_RX_CLK/ETH2_RMII_REF_CLK | LCD_B3 | LCD_R6 | SHRTIM1_CHB2 | ATIM1_CH1 | ATIM2_BKIN2 | USART1_CK | UART1_RX | USB1_SOF | I2C3_SCL | I2C5_SCL | ESC_P1_MII_RX_CLK | - | - | EVENTOUT | RCC_MCO1 |
| PA9 | ETH1_MII_TX_ER/ETH1_GMII_TX_ER | LCD_R5 | DVP1_D0 | SPI2_SCK | I2S2_CK | SHRTIM1_CHC1 | ATIM1_CH2 | USART1_TX | LPUART1_TX | USB1_VBUS | I2C3_SMB_A | I2C5_SMB_A | ESC_SYNC0 | - | EVENTOUT | - |
| PA10 | LCD_B1 | LCD_B4 | DVP1_D1 | SHRTIM1_CHC2 | ATIM1_CH3 | USART1_RX | LPUART1_RX | USB1_ID | ESC_P1_LI_NK | - | - | - | - | - | EVENTOUT | - |
| PA13 | - | - | - | - | - | - | - | - | - | - | - | - | - | - | EVENTOUT | JTMS/SWDIO |
| PA14 | - | - | - | - | - | - | - | - | - | - | - | - | - | - | EVENTOUT | JTCK/SWCLK |
| PA15 | LCD_B6 | LCD_R3 | SPI1_NSS | SPI3_NSS | SPI4_NSS | I2S1_WS | I2S3_WS | I2S4_WS | - | GTIMA1_CH1 | GTIMA1_ETR | UART9_DE/UART9_RTS | UART11_TX | - | EVENTOUT | JTDI |

3.3.2 GPIOB Multiplexing Function

Table 3-3 GPIOB Multiplexing Function

| Port | AF0 | AF1 | AF2 | AF3 | AF4 | AF5 | AF6 | AF7 | AF8 | AF9 | AF10 | AF11 | AF12 | AF13 | AF14 | AF15 |
|------|--|---|---|--------------------------------|-------------|--------------------|--------------------|--------------------|-----------------------|------------------|----------------------|--------------------|------------------|-----------------|----------|---------------|
| PB0 | - | xSPI2_IO1 | ETH1_MII_RXD2/ETH1_GMII_RXD2 | LCD_G1 | LCD_R3 | ATIM1_CH2N | ATIM2_CH2N | GTIMA2_C H3 | UART9_CTS | DSMU_CKOUT | ESC_P0_MII_RXD2 | - | - | - | EVENTOUT | - |
| PB1 | - | xSPI2_IO0 | ETH1_MII_RXD3/ETH1_GMII_RXD3 | LCD_G0 | LCD_R6 | DVP1_MCLK | SPI3_MISO | ATIM1_CH3N | ATIM2_CH3N | GTIMA2_C H4 | DSMU_DATIN1 | ESC_P0_MII_RXD3 | - | - | EVENTOUT | - |
| PB2 | - | - | xSPI2_CLK/xSPI2_CLKIN | ETH1_MII_TX_ER/ETH1_GMII_TX_ER | DVP1_HSYNC | DVP2_D12 | SPI3_MOSI | I2S3_SDO | ATIM1_CH4N | ATIM2_CH4N | GTIMA5_ETR | DSMU_CKIN1 | ESC_LED_ERR | - | EVENTOUT | RTC_OUT2 |
| PB3 | SDMMC2_D2 | SPI1_SCK | SPI3_SCK | SPI4_SCK | I2S1_CK | I2S3_CK | I2S4_CK | - | GTIMA1_C H2 | GTIMA6_ETR | UART11_RX | - | - | - | EVENTOUT | JTDO/TRACESWO |
| PB4 | ETH1_PHY_INTN | SDMMC2_D3 | SPI1_MISO | SPI2_NSS | SPI3_MISO | SPI4_MISO | I2S1_SDI | I2S2_WS | I2S3_SDI | I2S4_SDI | GTIMA2_C H1 | GTIMB2_B RK | UART11_TX | - | EVENTOUT | JTRST |
| PB5 | SDRAM_CKE1 | - | ETH1_PPS_OUT | LCD_B5 | DVP1_D10 | SPI1_MOSI/I2S1_SDO | SPI3_MOSI/I2S3_SDO | SPI4_MOSI/I2S4_SDO | GTIMA2_C H2 | GTIMB3_B RK | UART10_RX | FDCAN2_RX | I2C1_SMBA | I2C4_SMBA | EVENTOUT | - |
| PB6 | SDRAM_NCE1 | - | SDMMC1_D6 | DVP1_D5 | GTIMA2_C H3 | GTIMA3_C H1 | GTIMB2_C H1N | USART1_TX | UART10_TX | LPUART1_TX | FDCAN2_TX | I2C1_SCL | I2C4_SCL | DSMU_DATIN5 | EVENTOUT | - |
| PB7 | ETH1_MII_TXD2/ETH1_GMII_TXD2 | SDMMC1_D7 | FEMC_NL/FEMC_NADV | DVP1_VSYNC | - | GTIMA2_C H4 | GTIMA3_C H2 | GTIMB3_C H1N | USART1_RX | LPUART1_RX | I2C1_SDA | I2C4_SDA | DSMU_CKIN5 | ESC_P0_MII_TXD2 | EVENTOUT | - |
| PB8 | ETH1_MII_TXD3 | SDMMC1_CKIN | SDMMC1_D4 | SDMMC2_D4 | LCD_B6 | DVP1_D6 | GTIMA2_ETR | GTIMA3_C H3 | GTIMB2_C H1P | UART9_RX | FDCAN1_RX | I2C1_SCL | I2C4_SCL | DSMU_CKIN7 | EVENTOUT | - |
| PB9 | SDMMC1_CDIR | SDMMC1_D5 | SDMMC2_D5 | LCD_B7 | DVP1_D7 | SPI2_NSS/I2S2_WS | GTIMA3_C H4 | GTIMB3_C H1P | UART9_TX | FDCAN1_TX | I2C1_SDA | I2C4_SDA | I2C4_SMBA | DSMU_DATIN7 | EVENTOUT | - |
| PB10 | - | ETH1_MII_RX_ER/ETH1_GMII_RX_ER | FEMC_D13/FEMC_DA13 | LCD_G4 | SPI2_SCK | I2S2_CK | SHRTIM1_SCOU | GTIMA1_C H3 | LPTIM2_IN1 | USART3_TX | I2C2_SCL | DSMU_DATIN7 | ESC_P0_MII_RX_ER | - | EVENTOUT | - |
| PB11 | ETH1_MII_TX_EN/ETH1_RMII_TX_EN/ETH1_GMII_TX_EN | FEMC_D15/FEMC_DA15 | LCD_G5 | SHRTIM1_SCIN | GTIMA1_C H4 | LPTIM2_ETR | USART3_RX | I2C2_SDA | DSMU_CKIN7 | ESC_P0_MII_TX_EN | - | - | - | - | EVENTOUT | - |
| PB12 | - | - | ETH1_MII_TXD0/ETH1_RMII_TXD0/ETH1_GMII_TXD0 | ESC_P0_MII_TXD0 | DVP2_D14 | SPI2_NSS/I2S2_WS | ATIM1_BKIN1 | LPTIM2_IN2 | USART3_CK | UART10_RX | FDCAN2_RX | USB2_ID | I2C2_SMBA | DSMU_DATIN1 | EVENTOUT | - |
| PB13 | - | ETH1_MII_TXD1/ETH1_RMII_TXD1/ETH1_GMII_TXD1 | SDMMC1_D0 | DVP1_D2 | SPI2_SCK | I2S2_CK | ATIM1_CH1N | LPTIM2_OUT | USART3_CTS/USART3_NSS | UART10_TX | FDCAN2_TX | USB2_VBUS | DSMU_CKIN1 | ESC_P0_MII_TXD1 | EVENTOUT | - |
| PB14 | SDRAM_D10 | SDMMC2_D0 | FEMC_D10/FEMC_DA10 | LCD_CLK | SPI2_MISO | I2S2_SDI | ATIM1_CH2N | ATIM2_CH2N | GTIMA7_C H1 | USART1_TX | USART3_DE/USART3_RTS | UART9_DE/UART9_RTS | USB2_DM | DSMU_DATIN2 | EVENTOUT | - |
| PB15 | SDRAM_D11 | SDMMC2_D1 | FEMC_D11/FEMC_DA11 | LCD_G7 | SPI2_MOSI | I2S2_SDO | ATIM1_CH3N | ATIM2_CH3N | GTIMA7_C H2 | USART1_RX | UART9_CTS | USB2_DP | DSMU_CKIN2 | - | EVENTOUT | RTC_REFIN |

3.3.3 GPIOC Multiplexing Function

Table 3-4 GPIOC Multiplexing Function

| Port | AF0 | AF1 | AF2 | AF3 | AF4 | AF5 | AF6 | AF7 | AF8 | AF9 | AF10 | AF11 | AF12 | AF13 | AF14 | AF15 |
|------|----------------|---|---|--------------------|----------------------------------|--------------|-------------|-----------------|----------------------|-------------------|-----------------|-----------------|------------|---------------|----------|----------|
| PC0 | SDRAM_NWE | SDRAM_D12 | ETH2_MII_RX_DV/ETH2_RMII_CRS_DV | FEMC_A25 | FEMC_D12/FEMC_DA12 | LCD_G2 | LCD_R5 | DSMU_CK1N0 | DSMU_DA_TIN4 | ESC_P1_MI1_RX_DV | ESC_LATC_H0 | - | - | - | EVENTOUT | - |
| PC1 | - | ETH1_MDC | SDMMC2_CK | LCD_G5 | SPI2_MOSI | I2S2_SDO | DSMU_CK1N4 | DSMU_DA_TIN0 | FEMC_D0/FEMC_DA0 | ESC_MDC | - | - | - | - | EVENTOUT | TRACED0 |
| PC2 | SDRAM_NCE0 | - | - | - | ETH1_MII_TXD2/ETH1_GMII_TX_D2 | DVP2_D6 | SPI2_MISO | I2S2_SDI | DSMU_CK1N1 | DSMU_CK_OUT | ESC_P0_MI1_TXD2 | - | - | - | EVENTOUT | - |
| PC3 | SDRAM_CKE0 | - | - | - | ETH1_MII_TX_CLK/ETH1_GMII_TX_CLK | DVP2_D7 | SPI2_MOSI | I2S2_SDO | DSMU_DA_TIN1 | ESC_P0_MI1_TX_CLK | - | - | - | - | EVENTOUT | - |
| PC4 | SDRAM_NCE0 | ETH1_MII_RXD0/ETH1_RMII_RXD0/ETH1_GMII_RXD0 | SDMMC2_CKIN | FEMC_A22 | LCD_R7 | I2S1_MCK | DSMU_CK1N2 | ESC_P0_MI1_RXD0 | - | - | - | - | - | - | EVENTOUT | - |
| PC5 | SDRAM_CKE0 | - | ETH1_MII_RXD1/ETH1_RMII_RXD1/ETH1_GMII_RXD1 | FEMC_A1 | LCD_DE | DSMU_DA_TIN2 | COMP1_OUT | SDRAM_NCAS | SDMMC2_SEL | ESC_P0_MI1_RXD1 | - | - | - | - | EVENTOUT | - |
| PC6 | SDMMC1_D0DIR | SDMMC1_D6 | SDMMC2_D6 | FEMC_NW_AIT | LCD_HSYN_C | DVP1_D0 | I2S2_MCK | SHRTIM1_CHA1 | ATIM2_CH1 | GTIMA2_C_H1 | USART4_TX | DSMU_CK1N3 | ESC_MDIO | ESC_RESET_OUT | EVENTOUT | - |
| PC7 | SDMMC1_D123DIR | SDMMC1_D7 | SDMMC2_D7 | FEMC_NE1/FEMC_NCE2 | LCD_G6 | DVP1_D1 | I2S3_MCK | SHRTIM1_CHA2 | ATIM2_CH2 | GTIMA2_C_H2 | USART4_RX | DSMU_DA_TIN3 | ESC_MDC | - | EVENTOUT | TRGIO |
| PC8 | SDMMC1_D0 | FEMC_NCE1/FEMC_NCE2 | FEMC_INT/FEMC_BUS_Y | DVP1_D2 | SHRTIM1_CHB1 | ATIM2_CH3 | GTIMA2_C_H3 | USART4_CK | UART10_DE/UART10_RTS | ESC_IRQ | - | - | - | - | EVENTOUT | TRACED1 |
| PC9 | - | SDMMC1_D1 | LCD_B2 | LCD_G3 | DVP1_D3 | I2S1_CKIN | I2S2_CKIN | I2S3_CKIN | I2S4_CKIN | ATIM2_CH4 | GTIMA2_C_H4 | UART10_CTS | I2C3_SDA | I2C5_SDA | EVENTOUT | RCC_MCO2 |
| PC10 | - | SDMMC1_D2 | LCD_R2 | LCD_B1 | DVP1_D8 | SPI3_SCK | I2S3_CK | USART3_TX | UART9_TX | I2C5_SDA | DSMU_CK1N5 | ESC_P0_MI1_TXD2 | - | - | EVENTOUT | - |
| PC11 | - | SDMMC1_D3 | LCD_B4 | DVP1_D4 | SPI3_MISO | I2S3_SDI | - | USART3_RX | UART9_RX | I2C5_SCL | DSMU_DA_TIN5 | ESC_P0_MI1_TXD3 | - | - | EVENTOUT | - |
| PC12 | SDRAM_D6 | SDMMC1_CK | FEMC_D6/FEMC_DA6 | LCD_R6 | DVP1_D9 | SPI3_MOSI | SP4_SCK | I2S3_SDO | I2S4_CK | GTIMB1_C_HIP | USART3_CK | UART10_TX | I2C5_SMB_A | ESC_LINK_ACT0 | EVENTOUT | TRACED3 |
| PC13 | - | - | - | - | - | - | - | - | - | RTC_TAMP1/RTC_TS | - | - | - | - | EVENTOUT | RTC_OUT1 |
| PC14 | - | - | - | - | - | - | - | - | - | TIMESTAMP | - | - | - | - | EVENTOUT | - |
| PC15 | - | - | - | - | - | - | - | - | - | TIMESTAMP | - | - | - | - | EVENTOUT | - |

3.3.4 GPIO Multiplexing Function

Table 3-5 GPIO Multiplexing Function

| Port | AF0 | AF1 | AF2 | AF3 | AF4 | AF5 | AF6 | AF7 | AF8 | AF9 | AF10 | AF11 | AF12 | AF13 | AF14 | AF15 |
|------|------------|--------------------|---------------------|--------------------|-------------------|-----------------------|----------------------|-----------------------|------------------------|---------------|---------------|---------------|------|------|----------|---------|
| PD0 | SDRAM_D2 | SDRAM_D11 | SDMMC1_WP | FEMC_D2/F EMC_DA2 | LCD_B1 | GTIMB2_C HIN | UART9_RX | UART13_C TS | FDCAN1_RX | DSMU_CKIN6 | ESC_LED_ERR | - | - | - | EVENTOUT | - |
| PD1 | SDRAM_D3 | SDRAM_D12 | SDMMC1_CD | FEMC_D3/F EMC_DA3 | GTIMB2_C HIP | UART9_TX | FDCAN1_TX | I2C1_SMB A | DSMU_DATIN6 | ESC_RESET_OUT | - | - | - | - | EVENTOUT | - |
| PD2 | SDRAM_D7 | SDRAM_D13 | SDMMC1_CMD | FEMC_D7/F EMC_DA7 | LCD_B2 | LCD_B7 | DVP1_D11 | GTIMA2_ETR | GTIMB1_B RK | GTIMB2_C H2 | UART10_RX | LPUART2_CTS | - | - | EVENTOUT | TRACED2 |
| PD3 | SDMMC1_RST | FEMC_CLK | LCD_G7 | DVP1_D5 | SPI2_SCK | I2S2_CK | GTIMB2_C H3 | USART2_CTS/USART2_NSS | LPUART2_DE/LPUART2_RTS | DSMU_CKOUT | ESC_IRQ | - | - | - | EVENTOUT | - |
| PD4 | - | SDMMC2_WP | FEMC_NOE | DVP1_D14 | SPI3_NSS | - | GTIMB2_C H4 | USART2_DE/USART2_RTS | LPUART2_TX | I2C1_SCL | - | - | - | - | EVENTOUT | - |
| PD5 | - | SDMMC2_CD | FEMC_NWE | DVP1_D15 | SPI3_MISO | GTIMB2_ETR | USART2_TX | LPUART2_RX | I2C1_SDA | ESC_SYNC1 | - | - | - | - | EVENTOUT | - |
| PD6 | - | SDMMC2_CK | FEMC_NWAIT | LCD_B2 | DVP1_D10 | SPI3_MOSI | I2S3_SDO | USART2_RX | DSMU_CKIN4 | DSMU_DATIN1 | ESC_LATCHI | - | - | - | EVENTOUT | - |
| PD7 | - | SDMMC2_CMD | FEMC_NE1/FEMC_NC E2 | SPI1_MOSI | SPI3_SCK | I2S1_SDO | ATIM4_BKIN1 | USART2_CK | DSMU_CKIN1 | DSMU_DATIN4 | ESC_LINK_ACT1 | - | - | - | EVENTOUT | - |
| PD8 | SDRAM_D13 | - | FEMC_D13/FEMC_DA13 | DVP2_HSY NC | SHRTIM2_S CIN | ATIM3_CH3 | USART3_TX | I2C7_SDA | DSMU_CKIN3 | ESC_LED_ERR | - | - | - | - | EVENTOUT | - |
| PD9 | SDRAM_D14 | FEMC_D14/FEMC_DA14 | DVP2_VSY NC | SHRTIM2_S COUT | ATIM3_CH3N | USART3_RX | I2C7_SCL | DSMU_DATIN3 | ESC_SYNC0 | - | - | - | - | - | EVENTOUT | - |
| PD10 | SDRAM_D15 | ETH1_CLK I25 | ETH2_PPS_OUT | FEMC_D15/FEMC_DA15 | LCD_B3 | ATIM1_CH4N | LPTIM2_OUT | USART3_CK | I2C7_SMB A | DSMU_CKOUT | - | - | - | - | EVENTOUT | - |
| PD11 | - | FEMC_A16/FEMC_CLE | DVP2_D15 | GTIMA3_ETR | LPTIM2_IN2 | USART3_CTS/USART3_NSS | I2C4_SMB A | ESC_LATC H0 | - | - | - | - | - | - | EVENTOUT | - |
| PD12 | - | FEMC_A17/FEMC_ALE | DVP1_D12 | GTIMA3_CHI | LPTIM1_IN1 | LPTIM2_IN1 | USART3_DE/USART3_RTS | UART12_TX | UART13_CTS | FDCAN3_RX | I2C4_SCL | ESC_LINK_ACT0 | - | - | EVENTOUT | - |
| PD13 | - | FEMC_A18 | DVP1_D13 | GTIMA3_CH2 | LPTIM1_OUT | UART12_RX | UART13_DE/UART13_RTS | FDCAN3_TX | I2C4_SDA | I2C8_SMB A | ESC_RESET_OUT | - | - | - | EVENTOUT | - |
| PD14 | SDRAM_D0 | SDRAM_C KE0 | ETH1_PPS_OUT | SDMMC1_D4 | FEMC_D0/F EMC_DA0 | ATIM3_CH4 | GTIMA3_CH3 | UART12_CTS | UART13_RX | I2C8_SDA | - | - | - | - | EVENTOUT | - |
| PD15 | SDRAM_D1 | ETH1_PHY_INTN | ETH2_PHY_INTN | SDMMC1_D5 | FEMC_D1/F EMC_DA1 | ATIM3_CH4N | GTIMA3_CH4 | UART12_DE/UART12_RTS | UART13_TX | I2C8_SCL | - | - | - | - | EVENTOUT | - |

3.3.5 GPIOE Multiplexing Function

Table 3-6 GPIOE Multiplexing Function

| Port | AF0 | AF1 | AF2 | AF3 | AF4 | AF5 | AF6 | AF7 | AF8 | AF9 | AF10 | AF11 | AF12 | AF13 | AF14 | AF15 |
|------|-------------------------------|-------------------------------|---------------------|-------------------|-------------------|-------------------|----------------------|----------------------|-------------------|-------------|---------------|------------------|-----------------|------|----------|----------|
| PE0 | SDRAM_D_QM0 | - | FEMC_NBL_0 | LCD_R0 | DVP1_D2 | SHRTIM1_S_CIN | GTIMA3_ETR | GTIMB1_C_H3 | LPTIM1_ETR | LPTIM2_ETR | UART12_RX | ESC_P0_LI_NK | - | - | EVENTOUT | - |
| PE1 | SDRAM_D_QM1 | - | FEMC_NBL_1 | LCD_R6 | DVP1_D3 | SHRTIM1_S_COUT | GTIMB1_C_H4 | LPTIM1_IN2 | UART12_TX | SDRAM_D15 | ESC_RESE_T_IN | - | - | - | EVENTOUT | - |
| PE2 | - | ETH1_MII_TXD3/ETH1_GMII_TX_D3 | FEMC_A23 | DVP2_D0 | SPI6_SCK | GTIMB1_ETR | USART5_RX | FDCAN4_TX | ESC_P0_MI1_TXD3 | - | - | - | - | - | EVENTOUT | TRACECLK |
| PE3 | ETH1_MII_TXD2/ETH1_GMII_TX_D2 | FEMC_A19 | DVP2_D1 | GTIMB1_BRK | USART5_TX | FDCAN4_RX | ESC_P0_MI1_TXD2 | - | - | - | - | - | - | - | EVENTOUT | TRACED0 |
| PE4 | ETH2_PHY_INTN | FEMC_A20 | LCD_B0 | DVP1_D4 | SPI6_NSS | GTIMB1_C_HIN | USART6_RX | DSMU_DATIN3 | ESC_LED_STATE_RUN | - | - | - | - | - | EVENTOUT | TRACED1 |
| PE5 | xSPI2_NCS_1 | FEMC_A21 | LCD_G0 | DVP1_D6 | SPI6_MISO | GTIMB1_C_HIP | USART6_TX | DSMU_CKIN3 | ESC_EEPR_OM_CLK | - | - | - | - | - | EVENTOUT | TRACED2 |
| PE6 | FEMC_A22 | LCD_G1 | DVP1_D7 | SPI6_MOSI | ATIM1_BKIN2 | GTIMB1_C_H2 | ESC_EEPR_OM_DATA | - | - | - | - | - | - | - | EVENTOUT | TRACED3 |
| PE7 | SDRAM_D4 | - | - | xSPI2_NCS_2 | ETH2_PHY_INTN | FEMC_D4/F EMC_DA4 | ATIM1_ETR | UART11_RX | I2C7_SDA | DSMU_DATIN2 | - | - | - | - | EVENTOUT | - |
| PE8 | SDRAM_D5 | SDRAM_A0 | - | - | SDMMC1_LEDCTRL | FEMC_D5/F EMC_DA5 | ATIM1_CHIN | UART11_TX | FDCAN5_TX | I2C7_SCL | DSMU_CKIN2 | COMP2_OUT | ESC_EEPR_OM_CLK | - | EVENTOUT | - |
| PE9 | SDRAM_D6 | SDRAM_A1 | - | - | SDMMC2_LEDCTRL | FEMC_D6/F EMC_DA6 | ATIM1_CH1 | UART11_DE/UART11_RTS | FDCAN5_RX | I2C7_SMB_A | DSMU_CKOUT | ESC_EEPR_OM_DATA | - | - | EVENTOUT | - |
| PE10 | SDRAM_D7 | SDRAM_A2 | - | - | FEMC_D7/F EMC_DA7 | ATIM1_CH2N | UART11_CTS | DSMU_DATIN4 | ESC_LED_STATE_RUN | - | - | - | - | - | EVENTOUT | - |
| PE11 | SDRAM_D8 | - | FEMC_D8/F EMC_DA8 | LCD_G3 | SPI6_NSS | ATIM1_CH2 | DSMU_CKIN4 | SDRAM_A3 | ESC_P0_LI_NK | - | - | - | - | - | EVENTOUT | - |
| PE12 | SDRAM_D9 | - | ETH1_GMII_RXD4 | FEMC_D9/F EMC_DA9 | LCD_B4 | SPI6_SCK | ATIM1_CH3N | UART13_RX | DSMU_DATIN5 | COMP1_OUT | ESC_MDC | - | - | - | EVENTOUT | - |
| PE13 | SDRAM_D10 | ETH1_GMII_RXD5 | FEMC_D10/F EMC_DA10 | LCD_DE | SPI6_MISO | ATIM1_CH3 | UART13_TX | FDCAN6_TX | I2C6_SDA | DSMU_CKIN5 | COMP2_OUT | ESC_MDIO | - | - | EVENTOUT | - |
| PE14 | SDRAM_D11 | - | ETH1_GMII_RXD6 | FEMC_D11 | LCD_CLK | SPI6_MOSI | ATIM1_CH4 | USART6_CK | UART13_CTS | FDCAN6_RX | I2C6_SCL | - | - | - | EVENTOUT | - |
| PE15 | SDRAM_D12 | ETH1_GMII_RXD7 | FEMC_D12/F EMC_DA12 | LCD_R7 | ATIM1_BKIN1 | USART5_CK | UART13_DE/UART13_RTS | I2C6_SMB_A | ESC_LED_RUN | - | - | - | - | - | EVENTOUT | - |

3.3.6 GPIOF Multiplexing Function

Table 3-7 GPIOF Multiplexing Function

| Port | AF0 | AF1 | AF2 | AF3 | AF4 | AF5 | AF6 | AF7 | AF8 | AF9 | AF10 | AF11 | AF12 | AF13 | AF14 | AF15 |
|------|-------------|-----------------------|------------------------------|-----------------------------------|--------------|--------------|--------------------------------|------------------|-----------------|------------------|-----------------------|-------------------|-----------------|-------------------|----------|------|
| PF0 | SDRAM_A0 | xSPI2_IO0 | ETH1_GMII_TXD4 | FEMC_A0 | DVP2_D0 | SHRTIM2_CHA1 | GTIMA1_C HI | GTIMA5_C HI | USART1_TX | FDCAN4_TX | I2C2_SDA | I2C5_SDA | COMP3_OUT | - | EVENTOUT | - |
| PF1 | SDRAM_A1 | SDRAM_D5 | xSPI2_IO1 | ETH1_GMII_TXD5 | FEMC_A1 | DVP2_D1 | SHRTIM2_CHA2 | GTIMA1_C H2 | GTIMA5_C H2 | USART1_RX | FDCAN4_RX | I2C2_SCL | I2C5_SCL | - | EVENTOUT | - |
| PF2 | SDRAM_A2 | xSPI2_IO2 | ETH1_GMII_TXD6 | FEMC_A2 | DVP2_D2 | SPI6_NSS | SHRTIM2_CHB1 | GTIMA1_C H3 | GTIMA5_C H3 | GTIMB2_ETR | USART1_CK | I2C2_SMB_A | I2C5_SMB_A | - | EVENTOUT | - |
| PF3 | SDRAM_A3 | xSPI2_IO3 | ETH1_GMII_TXD7 | FEMC_A3 | DVP2_D3 | SPI6_SCK | SHRTIM2_CHB2 | GTIMA1_C H4 | GTIMA5_C H4 | GTIMB2_C H4 | USART1_CTS/USART1_NSS | I2C6_SDA | - | - | EVENTOUT | - |
| PF4 | SDRAM_A4 | SDRAM_D4 | xSPI2_CLK/xSPI2_CLKIN | ETH2_MII_RX_CLK/ETH2_RMII_REF_CLK | FEMC_A4 | DVP2_D4 | SPI6_MISO | SHRTIM2_CHC1 | GTIMA1_ETR | GTIMB2_C H3 | USART1_DE/USART1_RTS | FDCAN5_TX | I2C6_SCL | ESC_P1_MII_RX_CLK | EVENTOUT | - |
| PF5 | SDRAM_A5 | xSPI2_NCLK | ETH1_GMII_GTX_CLK | FEMC_A5 | DVP2_D5 | SPI6_MOSI | SHRTIM2_CHC2 | ATIM3_BKIN | GTIMB2_C H2 | FDCAN5_RX | I2C6_SMB_A | ESC_P0_MII_RX_CLK | - | - | EVENTOUT | - |
| PF6 | - | xSPI2_IO3 | ETH2_MDI0 | DVP1_PIXCLK | DVP2_D5 | SPI5_NSS | ATIM3_ETR | ATIM4_ETR | GTIMA5_C HI | GTIMB2_C HIP | UART11_RX | FDCAN3_RX | ESC_MDIO | - | EVENTOUT | - |
| PF7 | - | xSPI2_IO2 | ETH2_MDC | DVP2_PIXCLK | SPI5_SCK | ATIM3_CH4 | ATIM4_CH3 | GTIMA5_C H2 | GTIMB3_C HIP | UART11_TX | FDCAN3_TX | ESC_MDC | - | - | EVENTOUT | - |
| PF8 | - | xSPI2_IO0 | ETH2_MII_COL | SDMMC2_LEDCTRL | DVP2_HSYNC | SPI5_MISO | ATIM3_CH1 | ATIM4_CH4 | GTIMA5_C H3 | GTIMB2_C HIN | UART11_DE/USART11_RTS | ESC_P0_MII_RXD0 | - | - | EVENTOUT | - |
| PF9 | - | xSPI2_IO1 | ETH2_MII_CRS | SDMMC1_LEDCTRL | DVP2_VSYNC | SPI5_MOSI | - | ATIM3_CH2 | ATIM4_CH1 | GTIMA5_C H4 | GTIMB3_C HIN | UART11_CTS | ESC_P0_MII_RXD1 | - | EVENTOUT | - |
| PF10 | - | xSPI2_CLK/xSPI2_CLKIN | ETH2_PPS_OUT | LCD_DE | DVP1_D11 | ATIM3_CH3 | ATIM4_CH2 | GTIMB2_B RK | FEMC_A3 | ESC_P1_MII_TX_EN | - | - | - | - | EVENTOUT | - |
| PF11 | SDRAM_N_RAS | - | DVP1_D12 | SPI5_MOSI | GTIMA6_C HI | I2C6_SDA | ETH2_MII_TX_EN/ETH2_RMII_TX_EN | ESC_P1_MII_TX_EN | - | - | - | - | - | - | EVENTOUT | - |
| PF12 | SDRAM_A6 | xSPI2_DQS | ETH2_MII_TXD0/ETH2_RMII_TXD0 | FEMC_A6 | DVP2_D6 | GTIMA6_C H2 | FDCAN6_TX | I2C6_SCL | ESC_P1_MII_TXD0 | - | - | - | - | - | EVENTOUT | - |
| PF13 | SDRAM_A7 | SDRAM_N_CE0 | ETH2_MII_TXD1/ETH2_RMII_TXD1 | FEMC_A7 | DVP2_D7 | - | GTIMA6_C H3 | USART7_CK | FDCAN6_RX | I2C4_SMB_A | I2C6_SMB_A | DSMU_DATIN6 | COMP3_OUT | ESC_P1_MII_TXD1 | EVENTOUT | - |
| PF14 | SDRAM_A8 | ETH2_MII_TXD2 | FEMC_A8 | DVP2_D8 | SHRTIM2_CHF1 | GTIMA6_C H4 | USART7_RX | FDCAN3_RX | I2C4_SCL | DSMU_CKIN6 | ESC_P1_MII_TXD2 | - | - | - | EVENTOUT | - |
| PF15 | SDRAM_A9 | SDRAM_B_A0 | ETH2_MII_TXD3 | FEMC_A9 | DVP2_D9 | SHRTIM2_CHF2 | LPTIM4_ETR | USART7_TX | FDCAN3_TX | I2C4_SDA | ESC_P1_MII_TXD3 | - | - | - | EVENTOUT | - |

3.3.7 GPIOG Multiplexing Function

Table 3-8 GPIOG Multiplexing Function

| Port | AF0 | AF1 | AF2 | AF3 | AF4 | AF5 | AF6 | AF7 | AF8 | AF9 | AF10 | AF11 | AF12 | AF13 | AF14 | AF15 |
|------|-----------|------------|-------------------------|------------|-----------------|--------------|------------|------------|-------------------|------------|-------------------|------|------|------|----------|------|
| PG0 | SDRAM_A10 | SDRAM_BA1 | xSPI2_IO4 | xSPI2_NCS2 | ETH2_MII_TX_CLK | FEMC_A10 | DVP2_D10 | ATIM4_BKIN | LPTIM4_IN1 | UART13_RX | ESC_P1_MII_TX_CLK | - | - | - | EVENTOUT | - |
| PG1 | SDRAM_A11 | SDRAM_A10 | xSPI2_IO5 | xSPI2_NCS3 | ETH2_MII_TX_ER | FEMC_A11 | DVP2_D11 | - | GTIMB1_ETR | LPTIM4_IN2 | UART13_TX | - | - | - | EVENTOUT | - |
| PG2 | SDRAM_A12 | SDRAM_DQM1 | ETH2_MII_RXD0/ETH2_RMII | FEMC_A12 | DVP2_D12 | SHRTIM2_SCIN | ATIM2_BKIN | GTIMA6_ETR | USART7_CTS/USART7 | FDCAN8_TX | ESC_P1_MII_RXD0 | - | - | - | EVENTOUT | - |

| | | | | | | | | | | | | | | | | | |
|------|---|---|--|---------------------|-------------|-----------------------|----------------------|----------------------|-----------------------|-----------------------|-----------------------|----------------------|-----------------|-----------------|----------|---------|--|
| | | | _RXD0 | | | | | | _NSS | | | | | | | | |
| PG3 | ETH2_MII_RXD1/ETH2_RMII_RXD1 | FEMC_A13 | DVP2_D13 | SHRTIM2_SCOUT | ATIM2_BKIN2 | GTIMA5_ETR | USART7_DE/USART7_RTS | FDCAN8_RX | ESC_P1_MI1_RXD1 | - | - | - | - | - | EVENTOUT | - | |
| PG4 | SDRAM_BA0 | ETH2_MII_RXD2 | SDMMC2_CK1N | SDMMC2_D4 | FEMC_A14 | DVP2_D14 | SHRTIM1_CHF1 | ATIM1_BK1N2 | USART6_CTS/USART6_NSS | I2C1_SDA | I2C8_SDA | ESC_P1_MI1_RXD2 | - | - | EVENTOUT | - | |
| PG5 | SDRAM_BA1 | - | ETH2_MII_RXD3 | SDMMC2_CD1R | SDMMC2_D5 | FEMC_A15 | DVP2_D15 | SHRTIM1_CHF2 | ATIM1_ETR | USART6_DE/USART6_RTS | I2C1_SCL | I2C8_SCL | ESC_P1_MI1_RXD3 | - | EVENTOUT | - | |
| PG6 | - | ETH2_MII_RX_ER | FEMC_NE3 | LCD_R7 | DVP1_D12 | SHRTIM1_CHE1 | GTIMB3_BRK | I2C1_SMB_A | I2C8_SMB_A | ESC_P1_MI1_RX_ER | - | - | - | - | EVENTOUT | - | |
| PG7 | xSPI2_DQS | ETH1_PHY_INTN | FEMC_INT/FEMC_BUSY | LCD_CLK | DVP1_D13 | SHRTIM1_CHE2 | USART4_CK | FDCAN7_TX | - | - | - | - | - | - | EVENTOUT | - | |
| PG8 | SDRAM_CLK | - | ETH1_PPS_OUT | LCD_G7 | SPI4_NSS | I2S4_WS | ATIM2_ETR | USART4_DE/USART4_RTS | FDCAN7_RX | ESC_P1_LI_NK | - | - | - | - | EVENTOUT | - | |
| PG9 | - | ETH2_MII_RXD0/ETH2_RMII_RXD0 | SDMMC2_D0 | FEMC_NC_E1/FEMC_NE2 | DVP1_VSYNC | SPI1_MISO | I2S1_SDI | USART4_RX | FDCAN3_TX | ESC_P1_MI1_RXD0 | - | - | - | - | EVENTOUT | - | |
| PG10 | xSPI2_IO6 | xSPI2_NCS4 | ETH2_MII_RXD1/ETH2_RMII_RXD1 | SDMMC2_D1 | FEMC_NE3 | LCD_B2 | LCD_G3 | DVP1_D2 | SPI1_NSS | I2S1_WS | - | FDCAN3_RX | ESC_P1_MI1_RXD1 | - | EVENTOUT | - | |
| PG11 | xSPI2_IO7 | xSPI2_NCSIN | ETH1_MII_TX_EN/ETH1_RMII_TX_EN/ETH1_GMII_TX_EN | SDMMC2_D2 | LCD_B3 | DVP1_D3 | SPI1_SCK | I2S1_CK | LPTIM1_IN2 | USART5_RX | ESC_P0_MI1_TX_EN | - | - | - | EVENTOUT | - | |
| PG12 | xSPI2_NCS1 | ETH1_MII_TXD1/ETH1_RMII_TXD1/ETH1_GMII_TXD1 | SDMMC2_D3 | FEMC_NE4 | LCD_B1 | LCD_B4 | DVP2_MCLK | SPI4_MISO | I2S4_SDI | GTIMA5_CHI | LPTIM1_IN1 | USART4_DE/USART4_RTS | USART5_TX | ESC_P0_MI1_TXD1 | EVENTOUT | - | |
| PG13 | ETH1_MII_TXD0/ETH1_RMII_TXD0/ETH1_GMII_TXD0 | SDMMC2_D0DIR | SDMMC2_D6 | FEMC_A24 | LCD_R0 | SPI4_SCK | I2S4_CK | GTIMA5_CH2 | LPTIM1_OUT | USART4_CTS/USART4_NSS | USART5_CTS/USART5_NSS | ESC_P0_MI1_TXD0 | - | - | EVENTOUT | TRACED0 | |
| PG14 | - | ETH1_MII_TXD1/ETH1_RMII_TXD1/ETH1_GMII_TXD1 | SDMMC2_D123DIR | SDMMC2_D7 | FEMC_A25 | LCD_B0 | SPI4_MOSI | I2S4_SDO | GTIMA5_CHB | LPTIM1_ETR | USART4_TX | USART5_DE/USART5_RTS | ESC_P0_MI1_TXD1 | - | EVENTOUT | TRACED1 | |
| PG15 | SDRAM_NCAS | xSPI2_DQS | ETH1_PHY_INTN | SDMMC2_RST | DVP1_D13 | USART4_CTS/USART4_NSS | USART5_CK | SDRAM_D14 | ESC_LINK_ACT0 | ESC_LED_ERR | - | - | - | - | EVENTOUT | - | |

3.3.8 GPIOH Multiplexing Function

Table 3-9 GPIOH Multiplexing Function

| Port | AF0 | AF1 | AF2 | AF3 | AF4 | AF5 | AF6 | AF7 | AF8 | AF9 | AF10 | AF11 | AF12 | AF13 | AF14 | AF15 |
|------|------------------------------|--------------------------------|---------------------------------|----------------------------|----------------------------|--------------|--------------|----------------------|----------------------|----------------------|-----------------|------------------|------------------|------|----------|------|
| PH0 | - | - | - | - | - | - | - | - | - | - | - | - | - | - | EVENTOUT | - |
| PH1 | - | - | - | - | - | - | - | - | - | - | - | - | - | - | EVENTOUT | - |
| PH2 | SDRAM_CKE0 | - | - | xSPI2_IO4 | ETH1_MII_CRS/ETH1_GMII_CRS | LCD_R0 | SHRTIM2_CHD1 | GTIMB3_C H2 | LPTIM1_IN2 | UART15_RX | ESC_LINK_ACT0 | ESC_P1_MI1_TX_EN | - | - | EVENTOUT | - |
| PH3 | SDRAM_NCE0 | - | xSPI2_IO5 | ETH1_MII_COL/ETH1_GMII_COL | LCD_R1 | SHRTIM2_CHD2 | GTIMB3_C H3 | USART7_CK | UART15_TX | ESC_P0_MI1_RX_ER | - | - | - | - | EVENTOUT | - |
| PH4 | ETH2_MII_TXD0/ETH2_RMII_TXD0 | LCD_G4 | LCD_G5 | DVP2_HSY_NC | SHRTIM2_CHE1 | GTIMB3_C H4 | USART7_RX | UART15_DE/UART15_RTS | FDCAN5_TX | I2C2_SCL | ESC_P1_MI1_TXD0 | - | - | - | EVENTOUT | - |
| PH5 | SDRAM_NWE | ETH2_MII_TXD1/ETH2_RMII_TXD1 | DVP2_PIXCLK | SPI5_NSS | SHRTIM2_CHE2 | GTIMB3_ETR | USART7_TX | UART15_CTS | FDCAN5_RX | I2C2_SDA | ESC_P1_MI1_TXD1 | - | - | - | EVENTOUT | - |
| PH6 | SDRAM_NCE1 | SDRAM_A4 | ETH1_MII_RXD2/ETH1_GMII_RXD2 | FEMC_BAA | DVP1_D8 | SPI5_SCK | ATIM1_CH4N | GTIMA7_CHI | LPTIM5_IN1 | UART14_RX | FDCAN7_TX | I2C2_SMB_A | ESC_P0_MI1_RXD2 | - | EVENTOUT | - |
| PH7 | SDRAM_CKE1 | ETH1_MII_RXD3/ETH1_GMII_RXD3 | FEMC_CRE | DVP1_D9 | SPI5_MISO | ATIM3_BKINI | LPTIM5_IN2 | UART14_TX | FDCAN7_RX | I2C3_SCL | SDRAM_A5 | ESC_P0_MI1_RXD3 | - | - | EVENTOUT | - |
| PH8 | SDRAM_D16 | SDRAM_A6 | ETH1_GMII_RXD4 | FEMC_D16 | LCD_R2 | DVP1_HSY_NC | ATIM3_CH1 | GTIMA4_ETR | UART10_DE/UART10_RTS | UART14_DE/UART14_RTS | FDCAN2_RX | I2C3_SDA | COMP4_OUT | - | EVENTOUT | - |
| PH9 | SDRAM_D17 | ETH1_GMII_RXD5 | FEMC_D17 | LCD_R3 | DVP1_D0 | ATIM3_CHIN | GTIMA7_C H2 | UART10_CTS | UART14_CTS | FDCAN2_TX | I2C3_SMB_A | SDRAM_A7 | - | - | EVENTOUT | - |
| PH10 | SDRAM_D18 | SDRAM_A8 | ETH1_GMII_RXD6 | FEMC_D18 | LCD_R4 | DVP1_D1 | ATIM3_CH2 | GTIMA4_CHI | I2C4_SMB_A | ESC_P0_MI1_RXD2 | - | - | - | - | EVENTOUT | - |
| PH11 | SDRAM_D19 | ETH1_GMII_RXD7 | FEMC_D19 | LCD_R5 | DVP1_D2 | ATIM3_CH2N | GTIMA4_C H2 | UART10_RX | I2C4_SCL | SDRAM_A9 | ESC_P0_MI1_RXD3 | - | - | - | EVENTOUT | - |
| PH12 | SDRAM_D20 | SDRAM_A11 | ETH2_MII_RX_DV/ETH2_RMII_CRS_DV | FEMC_D20 | LCD_R6 | DVP1_D3 | SPI7_NSS | ATIM3_ETR | GTIMA4_C H3 | UART10_TX | I2C4_SDA | COMP4_OUT | ESC_P1_MI1_RX_DV | - | EVENTOUT | - |
| PH13 | SDRAM_D21 | ETH2_MII_TX_EN/ETH2_RMII_TX_EN | FEMC_D21 | LCD_G2 | SPI7_NSS | ATIM2_CHIN | UART9_TX | FDCAN1_TX | I2C9_SMB_A | ESC_P1_MI1_TX_EN | - | - | - | - | EVENTOUT | - |
| PH14 | SDRAM_D22 | ETH2_MII_TXD0/ETH2_RMII_TXD0 | FEMC_D22 | LCD_G3 | DVP1_D4 | SPI7_MISO | ATIM2_CH2N | USART6_RX | UART9_RX | FDCAN1_RX | I2C9_SDA | ESC_P1_MI1_TXD0 | - | - | EVENTOUT | - |
| PH15 | SDRAM_D23 | - | ETH2_MII_TXD1/ETH2_RMII_TXD1 | FEMC_D23 | LCD_G4 | DVP1_D11 | SPI7_MOSI | ATIM2_CH3N | USART6_TX | I2C9_SCL | ESC_P1_MI1_TXD1 | - | - | - | EVENTOUT | - |

3.3.9 GPIOI Multiplexing Function

Table 3-10 GPIOI Multiplexing Function

| Port | AF0 | AF1 | AF2 | AF3 | AF4 | AF5 | AF6 | AF7 | AF8 | AF9 | AF10 | AF11 | AF12 | AF13 | AF14 | AF15 |
|------|-----------------|----------------|----------------|----------------|--------------|--------------|-------------------|--------------|---------------|---------------|------------------|-------------|------------------|------|------------|-----------|
| PI0 | SDRAM_D2_4 | FEMC_D24 | LCD_G5 | DVP1_D13 | SPI2_NSS | I2S2_WS | ATIM2_CH4N | GTIMA4_C_H4 | I2C10_SDA | ESC_RESE_T_IN | - | - | - | - | EVENTO_U_T | - |
| PI1 | SDRAM_D2_5 | SDRAM_D8 | ETH2_MII_RXD0 | FEMC_D25 | LCD_G6 | DVP1_D8 | SPI2_SCK | I2S2_CK | ATIM2_BK1_N2 | USART8_CK | I2C8_SMB_A | I2C10_SCL | ESC_P1_MI1_RXD0 | - | EVENTO_U_T | - |
| PI2 | SDRAM_D2_6 | ETH2_MII_RXD1 | FEMC_D26 | LCD_G7 | DVP1_D9 | SPI2_MISO | I2S2_SDI | ATIM2_CH4 | USART8_RX_X | LPUART2_TX | I2C8_SDA | SDRAM_D9 | ESC_P1_MI1_RXD1 | - | EVENTO_U_T | - |
| PI3 | SDRAM_D2_7 | SDRAM_D10 | ETH2_MII_RX_ER | FEMC_D27 | DVP1_D10 | SPI2_MOSI | I2S2_SDO | ATIM2_ET_R | USART8_TX_X | LPUART2_RX | I2C8_SCL | I2C10_SMB_A | ESC_P1_MI1_RX_ER | - | EVENTO_U_T | - |
| PI4 | SDRAM_D_QM2 | xSPI2_NCS_2 | ETH1_GMII_TXD4 | FEMC_NBL_2 | LCD_B4 | DVP1_D5 | DVP2_D8 | ATIM2_BK1_N1 | USART8_RX_X | I2C10_SMB_A | SDRAM_D0 | ESC_SYNC_0 | - | - | EVENTO_U_T | - |
| PI5 | SDRAM_D_QM3 | SDRAM_D1 | xSPI2_NCS_3 | ETH1_GMII_TXD5 | FEMC_NBL_3 | LCD_B5 | DVP1_VSY_NC | DVP2_D9 | ATIM2_CH1 | USART8_TX_X | I2C10_SDA | ESC_LATC_H1 | - | - | EVENTO_U_T | - |
| PI6 | SDRAM_D2_8 | xSPI2_NCS_4 | ETH1_GMII_TXD6 | FEMC_D28 | LCD_B6 | DVP1_D6 | DVP2_D10 | ATIM2_CH2 | USART8_CK | I2C10_SCL | SDRAM_D2 | ESC_IRQ | - | - | EVENTO_U_T | - |
| PI7 | SDRAM_D2_9 | SDRAM_D3 | xSPI2_NCS1_N | ETH1_GMII_TXD7 | FEMC_D29 | LCD_B7 | DVP1_D7 | DVP2_D11 | ATIM2_CH3 | ESC_LINK_ACT1 | - | - | - | - | EVENTO_U_T | - |
| PI8 | ETH2_MII_TX_CLK | SDMMC1_SEL | SDMMC2_SEL | SPI7_SCK | LPTIM3_IN1 | FDCAN1_TX | ESC_P1_MI1_TX_CLK | - | - | - | - | - | - | - | EVENTO_U_T | RTC_OUT_2 |
| PI9 | SDRAM_D3_0 | xSPI2_IO0 | FEMC_D30 | LCD_VSYN_C | - | GTIMA7_C_H5 | LPTIM3_IN2 | UART9_RX | FDCAN1_RX_X | I2C9_SMB_A | SDRAM_D6 | ESC_LATC_H0 | - | - | EVENTO_U_T | - |
| PI10 | SDRAM_D3_1 | SDRAM_D7 | xSPI2_IO1 | ETH1_MII_RX_ER | FEMC_D31 | LCD_HSYN_C | GTIMA7_C_H4 | LPTIM3_ET_R | FDCAN4_TX_X | I2C9_SDA | ESC_P0_MI1_RX_ER | - | - | - | EVENTO_U_T | - |
| PI11 | xSPI2_IO2 | SDMMC1_LEDCTRL | SDMMC2_LEDCTRL | FEMC_D0 | LCD_G6 | GTIMA7_ETR | FDCAN4_RX_X | I2C9_SCL | ESC_RESE_T_IN | - | - | - | - | - | EVENTO_U_T | - |
| PI12 | xSPI2_IO3 | FEMC_A4 | LCD_HSYN_C | DVP2_D2 | SPI7_NSS | GTIMA7_C_H3 | FDCAN6_TX_X | I2C7_SDA | - | - | - | - | - | - | EVENTO_U_T | - |
| PI13 | xSPI2_CLK | FEMC_A7 | LCD_VSYN_C | DVP2_D3 | SPI7_MISO | GTIMA7_C_H4 | FDCAN6_RX_X | I2C7_SCL | - | - | - | - | - | - | EVENTO_U_T | - |
| PI14 | xSPI2_NCLK | FEMC_A9 | LCD_CLK | DVP2_D4 | SPI7_MOSI | ATIM3_BK1_N2 | GTIMA7_ETR | I2C7_SMB_A | - | - | - | - | - | - | EVENTO_U_T | - |
| PI15 | ETH2_PPS_OUT | LCD_G2 | LCD_R0 | DVP2_D13 | ATIM3_BK1_N2 | GTIMB3_ETR | - | - | - | - | - | - | - | - | EVENTO_U_T | - |

3.3.10 GPIOJ Multiplexing Function

Table3-11 GPIOJ Multiplexing Function

| Port | AF0 | AF1 | AF2 | AF3 | AF4 | AF5 | AF6 | AF7 | AF8 | AF9 | AF10 | AF11 | AF12 | AF13 | AF14 | AF15 |
|------|----------------------|---------------|----------|------------|-------------------|--------------|--------------|-----------------|------------------|-------------------|------------------|------|------|------|----------|--------|
| PJ0 | ETH2_MII_TXD2 | LCD_R1 | LCD_R7 | - | ATIM4_ETR | GTIMB3_C_HIN | UART15_RX | FDCAN8_TX | I2C9_SDA | ESC_P1_MI1_TXD2 | - | - | - | - | EVENTOUT | - |
| PJ1 | xSPI2_IO4 | ETH2_MII_TXD3 | LCD_R2 | DVP2_VSYNC | SPI7_SCK | ATIM4_CH1 | GTIMB3_C_HIP | UART15_TX | FDCAN8_RX | I2C9_SCL | ESC_P1_MI1_TXD3 | - | - | - | EVENTOUT | - |
| PJ2 | xSPI2_IO5 | LCD_R3 | DVP1_D15 | SPI7_NSS | ATIM4_CH1N | GTIMB3_C_H2 | UART15_RTS | I2C9_SMB_A | ESC_SYNC1 | - | - | - | - | - | EVENTOUT | - |
| PJ3 | ETH2_MII_RX_DV | LCD_R4 | DVP1_D14 | SPI7_MISO | ATIM4_CH2 | GTIMB3_C_H3 | UART13_RTS | UART15_CTS | FDCAN7_TX | I2C9_SDA | ESC_P1_MI1_RX_DV | - | - | - | EVENTOUT | - |
| PJ4 | ETH2_MII_RX_CLK | LCD_R5 | DVP1_D13 | SPI7_MOSI | ATIM4_CH2N | GTIMB3_C_H4 | UART13_CTS | FDCAN7_RX | I2C9_SCL | ESC_P1_MI1_RX_CLK | - | - | - | - | EVENTOUT | - |
| PJ5 | ETH2_MII_TX_ER | LCD_R6 | DVP1_D9 | - | ATIM4_BK1N2 | LPTIM5_ETR | ESC_IRQ | - | - | - | - | - | - | - | EVENTOUT | - |
| PJ6 | FEMC_D2 | LCD_R7 | DVP2_D8 | ATIM2_CH2 | FDCAN7_TX | - | - | - | - | - | - | - | - | - | EVENTOUT | - |
| PJ7 | FEMC_D3 | LCD_G0 | DVP2_D9 | ATIM2_CH2N | FDCAN7_RX | - | - | - | - | - | - | - | - | - | EVENTOUT | TRGIN |
| PJ8 | ETH2_MII_RXD2 | LCD_G1 | DVP2_D10 | ATIM1_CH3N | ATIM2_CH1 | USART8_CTS | UART12_TX | UART14_RTS | FDCAN8_TX | I2C8_SDA | ESC_P1_MI1_RXD2 | - | - | - | EVENTOUT | - |
| PJ9 | ETH2_MII_RXD3 | LCD_G2 | DVP2_D11 | ATIM1_CH3 | ATIM2_CH1N | USART8_RTS | UART12_RX | UART14_CTS | FDCAN8_RX | I2C8_SCL | ESC_P1_MI1_RXD3 | - | - | - | EVENTOUT | - |
| PJ10 | FEMC_D5/ FEMC_DA5 | LCD_G3 | DVP2_D12 | SPI5_MOSI | ATIM1_CH2N | ATIM2_CH2 | UART12_CTS | UART14_RX | I2C8_SMB_A | ESC_EEPR_OM_CLK | - | - | - | - | EVENTOUT | - |
| PJ11 | FEMC_D6/ FEMC_DA6 | LCD_G4 | DVP2_D13 | SPI5_MISO | ATIM1_CH2 | ATIM2_CH2N | UART12_RTS | UART14_TX | ESC_EEPR_OM_DATA | - | - | - | - | - | EVENTOUT | - |
| PJ12 | SDMMC1_SEL | FEMC_BA_A | LCD_B0 | LCD_G3 | DVP2_D15 | ATIM4_CH3 | I2C10_SMB_A | ESC_P0_MI1_TXD2 | - | - | - | - | - | - | EVENTOUT | TRGOUT |
| PJ13 | SDMMC2_SEL | FEMC_NBL0 | LCD_B1 | LCD_B4 | DVP2_D14 | ATIM4_CH3N | I2C10_SDA | ESC_P0_MI1_TXD3 | - | - | - | - | - | - | EVENTOUT | - |
| PJ14 | FEMC_CRE | LCD_B2 | DVP2_D13 | ATIM4_CH4 | I2C10_SCL | - | - | - | - | - | - | - | - | - | EVENTOUT | - |
| PJ15 | FEMC_BA_A | LCD_B3 | DVP2_D12 | ATIM4_CH4N | ESC_LED_STATE_RUN | - | - | - | - | - | - | - | - | - | EVENTOUT | - |

3.3.11 GPIOK Multiplexing Function

Table 3-1 GPIOK Multiplexing Function

| Port | AF0 | AF1 | AF2 | AF3 | AF4 | AF5 | AF6 | AF7 | AF8 | AF9 | AF10 | AF11 | AF12 | AF13 | AF14 | AF15 |
|------|--------------|----------|---------|-------------|-------------|-------------|--------------|-------------|-----|-----|------|------|------|------|----------|------|
| PK0 | ETH2_MII_COL | LCD_G5 | DVP2_D7 | SPI5_SCK | ATIM1_CH1N | ATIM2_CH3 | I2C3_SCL | ESC_LED_ERR | - | - | - | - | - | - | EVENTOUT | - |
| PK1 | ETH2_MII_CRS | LCD_G6 | DVP2_D6 | SPI5_NSS | ATIM1_CH1 | ATIM2_CH3N | I2C3_SDA | ESC_LED_RUN | - | - | - | - | - | - | EVENTOUT | - |
| PK2 | FEMC_A11 | LCD_G7 | DVP2_D5 | ATIM1_BK1N1 | ATIM2_BK1N1 | I2C3_SMB_A | ESC_P0_LI_NK | - | - | - | - | - | - | - | EVENTOUT | - |
| PK3 | xSPI2_IO6 | FEMC_D7 | LCD_B4 | DVP2_D0 | ATIM4_BK1N2 | I2C10_SDA | - | - | - | - | - | - | - | - | EVENTOUT | - |
| PK4 | xSPI2_IO7 | FEMC_D9 | LCD_B5 | DVP2_D1 | GTIMA6_C_H1 | I2C10_SCL | ESC_LATC_H1 | - | - | - | - | - | - | - | EVENTOUT | - |
| PK5 | xSPI2_NCS1 | FEMC_D11 | LCD_B6 | DVP2_D2 | GTIMA6_C_H2 | I2C10_SMB_A | - | - | - | - | - | - | - | - | EVENTOUT | - |
| PK6 | xSPI2_DQS | FEMC_A12 | LCD_B7 | DVP2_D3 | GTIMA6_C_H3 | I2C10_SDA | - | - | - | - | - | - | - | - | EVENTOUT | - |
| PK7 | - | FEMC_A15 | LCD_DE | DVP2_D4 | GTIMA6_C_H4 | I2C10_SCL | ESC_LATC_H0 | - | - | - | - | - | - | - | EVENTOUT | - |

4 Electrical Characteristics

4.1 Test Conditions

Unless otherwise specified, all voltages are referenced to VSS.

4.1.1 Minimum and Maximum Values

For Beta versions, minimum and maximum values are based on design simulations.

Notes under each table indicate data obtained through comprehensive evaluation, design simulation, and/or process characteristics, which will not be tested in production lines. Based on comprehensive evaluation, minimum and maximum values are derived by taking the average value from sample testing, plus or minus three times the standard distribution (average $\pm 3\Sigma$).

4.1.2 Typical Values

Unless otherwise specified, typical data is based on $T_A=25^\circ\text{C}$ and $V_{DD}=3.3\text{V}$ (voltage range $1.8\text{V} \leq V_{DD} \leq 3.6\text{V}$).

These data are provided only as design guidance and are not tested.

4.1.3 Typical Curves

Unless otherwise specified, typical curves are provided only as design guidance and are not tested.

4.1.4 Load Capacitance

The load conditions for measuring pin parameters are shown in Figure 4-1.

Figure 4-1: Load Conditions for Pins

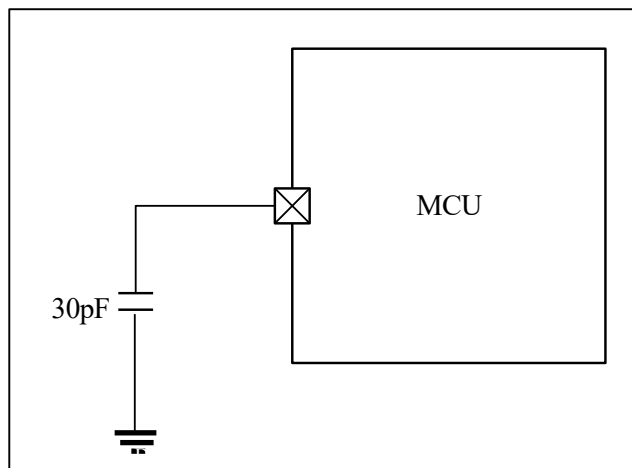

4.1.5 Pin Input Voltage

The method for measuring input voltage on pins is shown in Figure 4-2.

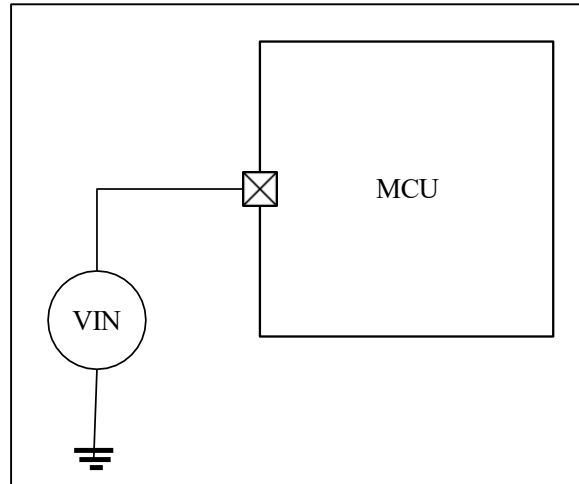
Figure 4-2: Pin Input Voltage

4.1.6 Power Supply Scheme

Figure 4-3 Power Supply Scheme

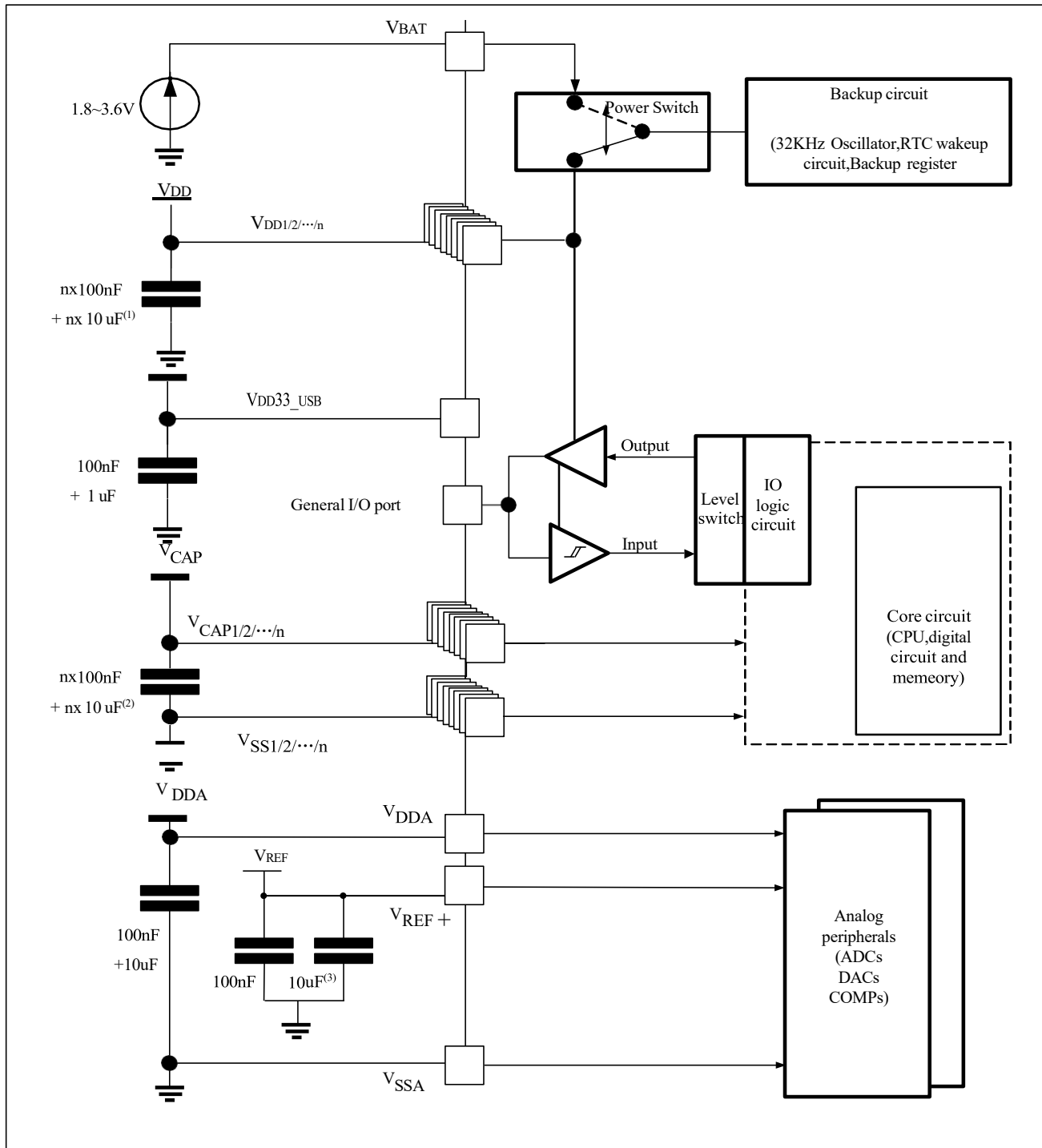

Note: 1. The 10 μ F capacitor in the above figure must be connected to the specified VDD.

4.1.7 Current Consumption Measurement

Figure 4-4: Current Consumption Measurement Scheme 4-1

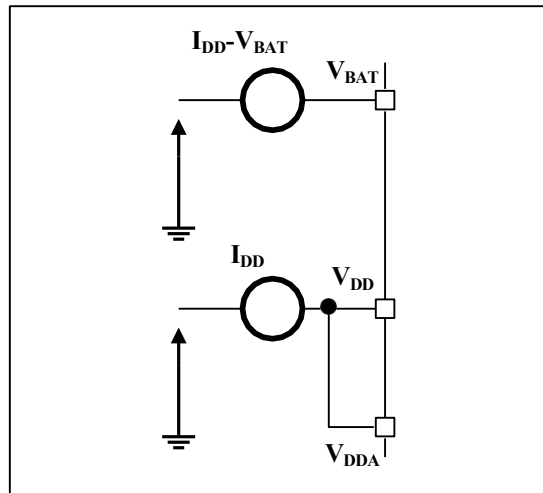

4.2 Absolute Maximum Ratings

Loads applied to the device that exceed the values given in the "Absolute Maximum Ratings" tables (Table 4-1, Table 4-2, Table 4-3) may cause permanent damage to the device. These values only indicate the maximum tolerable loads and do not imply that the device will function correctly under these conditions. Long-term operation at maximum values will affect device reliability.

Table 4-1: Voltage Characteristics

| Symbol | Description | Minimum | Maximum | Unit |
|----------------------|--|--------------------|----------------|------|
| $V_{DD} - V_{SS}$ | External main supply voltage (including V_{DDA} and V_{DD})(¹) | -0.3 | 4.0 | V |
| V_{IN} | Input voltage on 5V-tolerant pins (³) | $V_{SS}-0.3$ | 5.5 | |
| | Input voltage on other pins (²) | $V_{SS}-0.3$ | $V_{DD} + 0.3$ | |
| $ \Delta V_{DDx} $ | Voltage difference between different supply pins | - | 50 | mV |
| $ V_{SSx} - V_{SS} $ | Voltage difference between different ground pins | - | 50 | |
| $V_{ESD(HBM)}$ | ESD electrostatic discharge voltage (human body model) | See Section 4.3.12 | | |

- All power supply (V_{DD} , V_{DDA}) and ground (V_{SS} , V_{SSA}) pins must always be connected to an external power system within the allowable range.
- V_{IN} should not exceed its maximum value; for current characteristics, refer to Table 4-2.
- When a 5V-tolerant pin receives 5.5V input, V_{DD} cannot be lower than 2.25V.

Table 4-2: Current Characteristics

| Symbol | Description | Maximum (¹) | Unit |
|------------------------|--|--------------------------|------|
| I_{VDD} | Total current through V_{DD}/V_{DDA} power lines (supply current) (1)(4) | TBD | mA |
| I_{VSS} | Total current through V_{SS} ground lines (output current) (1)(4) | TBD | |
| I_{IO} | Output sink current on any I/O and control pin | 12 | |
| | Output source current on any I/O and control pin | -12 | |
| $I_{IN(PIN)}^{(2)(3)}$ | Injection current for NRST pin | -5/0 | |
| | Injection current for other pins | +/-5 | |

1. All power supply (VDD, VDDA) and ground (VSS, VSSA) pins must always be connected to an external power system within the allowable range.
2. When $V_{IN} > V_{DD}$, there is a forward injection current; when $V_{IN} < V_{SS}$, there is a reverse injection current. IINJ(PIN) should not exceed its maximum value; for voltage characteristics, refer to Table 4-1.
3. Reverse injection current will interfere with the device's analog performance. See Section 4.3.27.
4. When maximum current occurs, the maximum allowed VDD voltage drop is $0.1V_{DD}$.

Table 4-3: Temperature Characteristics

| Symbol | Description | Value | Unit |
|-----------|------------------------------|-------------|------|
| T_{STG} | Storage temperature range | -40 ~ + 150 | °C |
| T_J | Maximum junction temperature | 125 | °C |

4.3 Operating Conditions

4.3.1 General Operating Conditions

Table 4-4: General Operating Conditions

| Symbol | Parameter | Conditions | Minimum | Maximum | Unit |
|------------------|---|--|---------|---------|------|
| f_{CPU} | Arm® Cortex®-M7 clock frequency | V _{CORE} = 0.9V | - | 600 | |
| f_{ACLK} | AXI clock frequency | V _{CORE} = 0.9V | - | 300 | |
| f_{HCLK} | AHB clock frequency | V _{CORE} = 0.9V | - | 300 | MHz |
| f_{PCLK} | APB clock frequency | V _{CORE} = 0.9V | - | 150 | |
| V _{DD} | Standard operating voltage | - | 2.3 | 3.63 | V |
| V _{DDA} | Analog section operating voltage | Must be the same as V _{DD} ⁽¹⁾ | 2.3 | 3.63 | V |
| V _{BAT} | Backup section operating voltage | - | 1.8 | 3.63 | V |
| T _A | Ambient temperature (temperature grade 7) | Maximum power consumption | -40 | TBD | °C |
| T _J | Junction temperature range | Temperature ⁷ | -40 | 125 | °C |

1. It is recommended to use the same power supply for V_{DD} and V_{DDA}. During power-up and normal operation, a maximum difference of 300mV is allowed between V_{DD} and V_{DDA}.

4.3.2 VCAP External Capacitor

The stability of the main regulator can be achieved by connecting an external capacitor CEXT to the VCAP pin. Table 4-5 specifies CEXT. Two external capacitors can be connected to the VCAP pin.

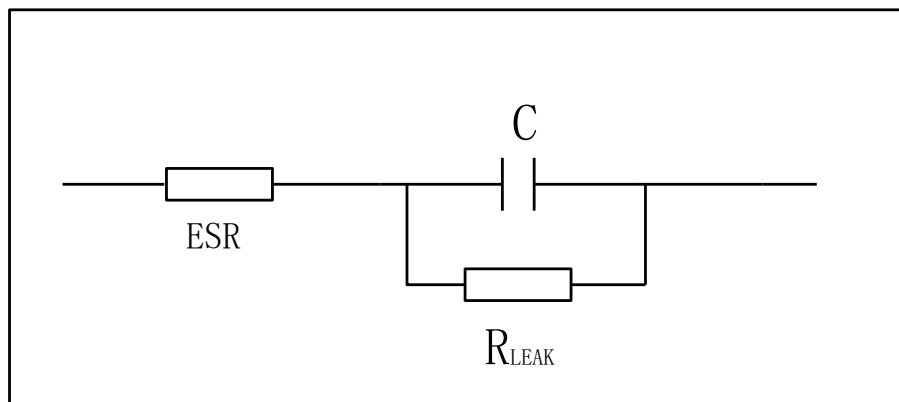
Figure 4-5: External Capacitor CEXT

- ESR is Equivalent Series Resistance

Table 4-5: VCAP Operating Conditions

| Symbol | Parameter | Conditions |
|------------------|---------------------------|------------|
| C _{EXT} | V _{DD} rise rate | TBD |
| ESR | External capacitor ESR | TBD |

4.3.3 Operating Conditions During Power-up and Power-down

The parameters given in the table below are tested at the ambient temperature (25°C) listed in Table 4-4.

Table 4-6: Operating Conditions During Power-up and Power-down

| Symbol | Parameter | Conditions | Minimum | Maximum | Unit |
|------------------|---------------------------|------------|---------|---------|------|
| t _{VDD} | V _{DD} rise rate | - | TBD | ∞ | μs/V |
| | V _{DD} fall rate | | TBD | ∞ | |

4.3.4 Embedded Reset and Power Control Module Characteristics

The parameters given in the table below are tested at the ambient temperature (25°C) and VDD supply voltage listed in Table 4-4.

Table 4-7: Embedded Reset and Power Control Module Characteristics

| Symbol | Parameter | Conditions | Minimum | Typical | Maximum | Unit |
|------------------|---|-----------------------------|---------|---------|---------|------|
| V _{PVD} | Programmable voltage detector level selection | PRS[2:0]=000 (Rising edge) | 1.7 | 1.78 | 1.86 | V |
| | | PRS[2:0]=000 (Falling edge) | 1.6 | 1.68 | 1.76 | V |
| | | PRS[2:0]=001 (Rising edge) | 1.8 | 1.88 | 1.96 | V |
| | | PRS[2:0]=001 (Falling edge) | 1.7 | 1.78 | 1.86 | V |
| | | PRS[2:0]=010 (Rising edge) | 1.9 | 1.98 | 2.06 | V |
| | | PRS[2:0]=010 (Falling edge) | 1.8 | 1.88 | 1.96 | V |
| | | PRS[2:0]=011 (Rising edge) | 2 | 2.08 | 2.16 | V |
| | | PRS[2:0]=011 (Falling edge) | 1.9 | 1.98 | 2.06 | V |
| | | PRS[2:0]=100 (Rising edge) | 2.09 | 2.18 | 2.26 | V |
| | | PRS[2:0]=100 (Falling edge) | 2.28 | 2.38 | 2.46 | V |
| | | PRS[2:0]=101 (Rising edge) | 2.19 | 2.28 | 2.36 | V |
| | | PRS[2:0]=101 (Falling edge) | 2.38 | 2.48 | 2.56 | V |
| | | PRS[2:0]=110 (Rising edge) | 2.28 | 2.38 | 2.46 | V |
| | | PRS[2:0]=110 (Falling edge) | 2.46 | 2.58 | 2.66 | V |
| | | PRS[2:0]=111 (Rising edge) | 2.36 | 2.48 | 2.56 | V |
| | | PRS[2:0]=111 (Falling edge) | 2.56 | 2.68 | 2.76 | V |
| | | PRS[2:0]=000 (Rising edge) | 2.46 | 2.58 | 2.66 | V |

| | | | | | | |
|----------------------|---|---------------------------------|------|------|------|----|
| | Programmable voltage detector level selection | PRS[2:0]=000 (Falling edge) | 2.66 | 2.78 | 2.86 | V |
| | | PRS[2:0]=001 (Rising edge) | 2.56 | 2.68 | 2.76 | V |
| | | PRS[2:0]=001 (Falling edge) | 2.76 | 2.88 | 2.96 | V |
| | | PRS[2:0]=010 (Rising edge) | 2.66 | 2.78 | 2.86 | V |
| | | PRS[2:0]=010 (Falling edge) | 2.6 | 2.68 | 2.76 | V |
| | | PRS[2:0]=011 (Rising edge) | 2.8 | 2.88 | 2.96 | V |
| | | PRS[2:0]=011 (Falling edge) | 2.7 | 2.78 | 2.86 | V |
| | | PRS[2:0]=100 (Rising edge) | 3.2 | 3.28 | 3.36 | V |
| | | PRS[2:0]=100 (Falling edge) | 3.1 | 3.18 | 3.26 | V |
| | | PRS[2:0]=101 (Rising edge) | 3.3 | 3.38 | 3.46 | V |
| | | PRS[2:0]=101 (Falling edge) | 3.2 | 3.28 | 3.36 | V |
| | | PRS[2:0]=110 (Rising edge) | 3.4 | 3.48 | 3.56 | V |
| | | PRS[2:0]=110 (Falling edge) | 3.2 | 3.28 | 3.36 | V |
| | | PRS[2:0]=111 (Rising edge) | 3.5 | 3.58 | 3.66 | V |
| | | PRS[2:0]=111 (Falling edge) | 3.4 | 3.48 | 3.56 | V |
| $V_{PVDhyst}^{(1)}$ | PVD hysteresis | - | - | 100 | - | mV |
| V_{POR} | VDD power-on/power-down reset threshold | - | - | 1.62 | - | V |
| V_{BOR} | BOR power-on/power-down reset threshold | BOR_CFG[2:0]=000(Rising edge) | 1.7 | 1.72 | 1.75 | V |
| | | BOR_CFG [2:0]=000(Falling edge) | 1.65 | 1.67 | 1.69 | V |
| | | BOR_CFG[2:0]=001(Rising edge) | 1.85 | 1.9 | 1.95 | V |
| | | BOR_CFG[2:0]=001(Falling edge) | 1.75 | 1.8 | 1.85 | V |
| | | BOR_CFG[2:0]=010(Rising edge) | 2.15 | 2.2 | 2.25 | V |
| | | BOR_CFG[2:0]=010(Falling edge) | 2.05 | 2.1 | 2.15 | V |
| | | BOR_CFG[2:0]=011(Rising edge) | 2.45 | 2.5 | 2.55 | V |
| | | BOR_CFG[2:0]=011(Falling edge) | 2.35 | 2.4 | 2.45 | V |
| | | BOR_CFG[2:0]=100(Rising edge) | 2.75 | 2.8 | 2.85 | V |
| | | BOR_CFG[2:0]=100(Falling edge) | 2.65 | 2.7 | 2.75 | V |
| $T_{RSTTEMPO}^{(1)}$ | Reset duration | - | - | 0.1 | | ms |

1. Guaranteed by design, not tested in production.

4.3.5 Built-in Bandgap Reference Voltage

The parameters given in the table below are tested at the ambient temperature (25°C) and VDD supply voltage listed in Table 4-4.

Table 4-8: Built-in Reference Voltage

| Symbol | Parameter | Conditions | Minimum | Typical | Maximum | Unit |
|--------------------|---|--|---------|---------|---------------------|-------------------------|
| V_{BG} | Built-in bandgap reference voltage | $-40^{\circ}\text{C} < T_J < +125^{\circ}\text{C}$ | 1.164 | 1.2 | 1.236 | V |
| $T_{S_BG}^{(1)}$ | ADC sampling time when reading internal bandgap reference voltage | | - | 5.1 | 17.1 ⁽²⁾ | μs |
| ΔV_{BG} | Internal voltage drift over the full temperature range | $V_{DD} = 3.3\text{V}$ $-40^{\circ}\text{C} < T_J < +125^{\circ}\text{C}$ | - | - | 10 | mV |
| T_{coeff} | Temperature coefficient | $-40^{\circ}\text{C} < T_J < +125^{\circ}\text{C}$ | - | - | 48 | ppm/ $^{\circ}\text{C}$ |

1. The minimum sampling time is obtained through multiple cycles in the application.
2. Guaranteed by design, not tested in production.

4.3.6 Built-in Bandgap Reference Voltage

The parameters given in the table below are tested at the ambient temperature (25°C) and VDD supply voltage listed in Table 4-4.

Table 4-10 Built-in Reference Voltage

| Symbol | Parameter | Conditions | Min | Typical | Max | Unit |
|--------------------|---|---|-------|---------|---------|-------------------------|
| VBG | Built-in bandgap reference voltage | $-40^{\circ}\text{C} < T_J < +125^{\circ}\text{C}$ | 1.164 | 1.2 | 1.236 | V |
| $T_{S_BG(1)}$ | ADC sampling time when reading internal bandgap reference voltage | - | 5.1 | - | 17.1(2) | μs |
| ΔV_{BG} | Internal voltage drift across the full temperature range | $V_{DD} = 3.3\text{V}$ $-40^{\circ}\text{C} < T_J < +125^{\circ}\text{C}$ | - | - | 10 | mV |
| T_{coeff} | Temperature coefficient | $-40^{\circ}\text{C} < T_J < +125^{\circ}\text{C}$ | - | - | 48 | ppm/ $^{\circ}\text{C}$ |

1. The shortest sampling time is obtained through multiple cycles in the application.
2. Guaranteed by design, not tested in production.

4.3.7 Supply Current Characteristics

Current consumption is a comprehensive indicator of various parameters and factors, including operating voltage, ambient temperature, I/O pin load, product software configuration, operating frequency, I/O pin switching rate, program location in memory, and executed code.

For current consumption measurement method details, see Figure 4-4.

All current consumption measurements in running modes given in this section are performed while executing a simplified set of code.

4.3.7.1 Maximum Current Consumption

The microcontroller is under the following conditions:

- All I/O pins are in input mode and connected to a static level—VDD or VSS (no load).
- All peripherals are turned off, unless otherwise specified.
- TCM memory access time is adjusted to the fastest frequency that can be run.
- Instruction prefetch function is enabled (Note: this parameter must be set before setting the clock and bus dividers).
- When peripherals are enabled: AXI, AHB, APB clock frequencies are configured to maximum.
- VDD=3.63V, junction temperature equals 125°C.

The parameters given in Tables 4-11 and 4-12 are tested at the ambient temperature (25°C) and VDD supply voltage listed in Table 4-4.

Table 4-11 Maximum Current Consumption in Run Mode, Data Processing Code Running from Internal Flash

| Symbol | Parameter | Conditions | | f _{HCLK} | Typical ⁽¹⁾ | Maximum ⁽¹⁾ | | | | Unit |
|-----------------|----------------------------|--|------|-------------------|------------------------|------------------------|-----------------------|------------------------|------------------------|------|
| | | | | | | T _J = 25°C | T _J = 85°C | T _J = 105°C | T _J = 125°C | |
| I _{DD} | Supply current in run mode | External clock, all peripherals enabled | 0.9V | TBD | TBD | TBD | TBD | TBD | TBD | mA |
| | | | | TBD | TBD | TBD | TBD | TBD | | |
| | | | 0.8V | TBD | TBD | TBD | TBD | TBD | | |
| | | | | TBD | TBD | TBD | TBD | TBD | | |
| | | External clock, all peripherals disabled | 0.9V | TBD | TBD | TBD | TBD | TBD | TBD | |
| | | | | TBD | TBD | TBD | TBD | TBD | | |
| | | | 0.8V | TBD | TBD | TBD | TBD | TBD | | |
| | | | | TBD | TBD | TBD | TBD | TBD | | |

1. Derived from comprehensive evaluation, not tested in production.

Table 4-12: Maximum Current Consumption in Sleep Mode

| Symbol | Parameter | Conditions | | f _{HCLK} | Typical ⁽¹⁾ | | Unit |
|-----------------|------------------------------|--|-----|-------------------|------------------------|------------------------|------|
| | | | | | TBD | T _J = 125°C | |
| I _{DD} | Supply current in sleep mode | External clock, all peripherals enabled | TBD | TBD | TBD | TBD | mA |
| | | | TBD | TBD | TBD | TBD | |
| | | | TBD | TBD | TBD | TBD | |
| | | | TBD | TBD | TBD | TBD | |
| | | External clock, all peripherals disabled | TBD | TBD | TBD | TBD | |
| | | | TBD | TBD | TBD | TBD | |
| | | | TBD | TBD | TBD | TBD | |
| | | | TBD | TBD | TBD | TBD | |

1. Guaranteed by comprehensive evaluation results, not tested in production.

4.3.7.2 Low-power Mode Current Consumption

MCU is under the following conditions:

- All I/O pins are in input mode and connected to a static level—VDD or VSS (no load).
- All peripherals are turned off unless specifically stated.

Table 4-13 Typical and maximum current consumption in stop and standby

| Symbol | Parameter | Conditions | Typical Value ⁽¹⁾ | Unit |
|----------------------|--------------------------------|--|------------------------------|------|
| | | | T _J =25°C | |
| I _{DD} | Supply current in STOP0 mode | Main power domain VDDDMAIN is in running mode, low-speed and high-speed internal RC oscillators and high-speed oscillator are in off state (no independent watchdog) | TBD | μA |
| | Supply current in STOP2 mode | Retention domain (VDDDRET) power remains on, main power domain VDDDMAIN off, low-speed and high-speed internal RC oscillators and high-speed oscillator are in off state (no independent watchdog) | TBD | |
| | Supply current in STANDBY mode | Low-speed oscillator on, RTC on, IWDG on, Backup SRAM retained | TBD | |
| | | Low-speed oscillator on, RTC off, IWDG off, Backup SRAM retained | TBD | |
| | | Low-speed oscillator on, RTC off, IWDG off, Backup SRAM not retained | TBD | |
| I _{DD_VBAT} | Supply current in VBAT mode | Low-speed oscillator and RTC are on | TBD | |

1. Guaranteed by comprehensive evaluation results, not tested in production.

4.3.8 External Clock Source Characteristics

4.3.8.1 High-Speed External Clock Source (External Clock)

High-speed external user clock is generated from an external source. In bypass mode, the HSE oscillator is turned off, and the input pin functions as a standard I/O. The external clock signal must comply with Table 4-12, and the recommended clock input waveform is shown in Figure 4-6.

Table 4-14 High-Speed External User Clock Characteristics⁽¹⁾

| Symbol | Parameter | Conditions | Minimum | Typical | Maximum | Unit |
|----------------------|--|---|-----------------|---------|---------|------|
| f _{HSE-ext} | User external clock frequency ⁽¹⁾ | VDD=3.3V, T _A = -40~105°C | 4 | 25 | 50 | MHz |
| V _{HSEH} | OSC_IN input pin high level voltage | | 0.7VDD | - | VDD | V |
| V _{HSEL} | OSC_IN input pin low level voltage | | V _{SS} | - | 0.3VDD | V |
| t _{w(HSE)} | OSC_IN high or low time ⁽¹⁾ | | 7 | - | - | ns |

1. Guaranteed by design..

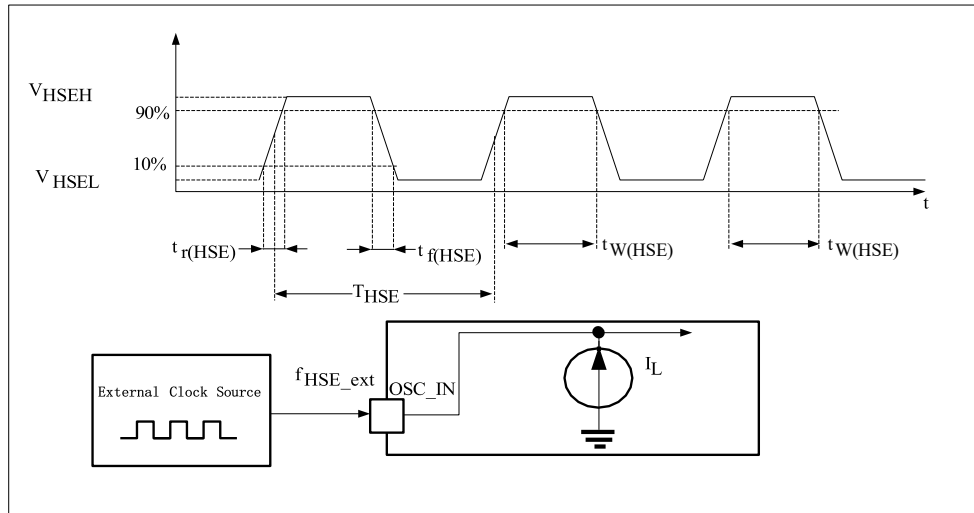
Figure 4-7 AC timing diagram for external high-speed clock source

4.3.8.2 Low-Speed External Clock Source (External Clock)

In bypass mode, the LSE oscillator is turned off, and the input pin functions as a standard I/O. The external clock signal must comply with Table 4-13, and the recommended clock input waveform is shown in Figure 4-7.

Table 4-15 Low-Speed External User Clock Characteristics(1)

| Symbol | Parameter | Conditions | Minimum | Typical | Maximum | Unit |
|---------------------|--|---|-----------------|---------|---------|------|
| $f_{LSE-ext}$ | User external clock frequency ⁽¹⁾ | VDD=3.3V, T _A = -40~105°C | - | 32.768 | 1000 | KHz |
| V _{LSEH} | OSC32_IN input pin high level voltage | | 0.7VDD | - | VDD | V |
| V _{LSEL} | OSC32_IN input pin low level voltage | | V _{ss} | - | 0.3VDD | V |
| t _{w(LSE)} | OSC32_IN high or low time ⁽¹⁾ | | 250 | - | - | ns |

1. Guaranteed by design..

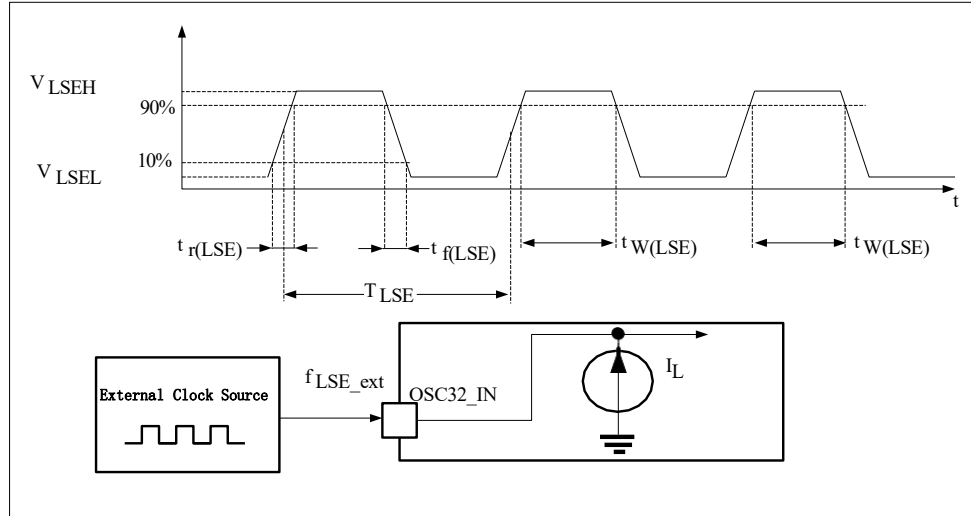
Figure 4-8 AC timing diagram for external low-speed clock source

4.3.8.3 High-Speed External Clock Source (External Crystal/Ceramic)

The high-speed external (HSE) clock can be provided by a 4 to 48 MHz crystal/ceramic resonator oscillator. All information given in this section is based on the analysis results of typical external component characteristics specified in the table below. In applications, the resonator and load capacitors must be placed as close as possible to the oscillator pins to minimize output distortion and startup stabilization time. For more details on resonator characteristics (frequency, package, accuracy), please consult the crystal resonator manufacturer.

Table 4-16 HSE 4–48MHz Oscillator Characteristics(1)

| Symbol | Parameter | Conditions ⁽²⁾ | Minimum | Typical | Maximum | Unit |
|-------------------------------------|-------------------------------------|---|---------|---------|---------|------|
| f | Oscillator frequency | - | 4 | 25 | 48 | MHz |
| R | Feedback resistance | - | - | 200 | - | KΩ |
| IDD _{HSE} | HSE drive current | During startup ⁽³⁾ | - | - | 4 | mA |
| | | VDD=3 V, R _m =30 Ω, CL=10 pF at 4 MHz | - | 0.8 | - | |
| | | VDD=3 V, R _m =30 Ω, CL=10 pF at 8 MHz | - | 1.2 | - | |
| | | VDD=3 V, R _m =30 Ω, CL=10 pF at 16 MHz | - | 1.5 | - | |
| | | VDD=3 V, R _m =30 Ω, CL=10 pF at 32 MHz | - | 1.65 | - | |
| | | VDD=3 V, R _m =30 Ω, CL=10 pF at 48 MHz | - | 2 | - | |
| G _{critmax} | Maximum oscillator transconductance | Startup | - | - | 1.5 | mA/V |
| t _{SU(HSE)} ⁽⁴⁾ | Startup time | VDD already stable | - | 2 | 5 | ms |

1. Guaranteed by design.

2. Resonator characteristic parameters are provided by the crystal/ceramic resonator manufacturer.
3. Time consumption occurs during the first 2/3 phase of the tSU(HSE) startup time.
4. tSU(HSE) is the startup time, measured from when HSE is enabled by software until a stable 8MHz oscillation is obtained. This value is measured on a standard crystal resonator and may vary considerably depending on the crystal manufacturer.

Note: For CL1 and CL2, it is recommended to use high-quality external ceramic capacitors in the range of 5 pF to 25 pF (typical values), which are designed for high-frequency applications, and their selection should meet the requirements of the crystal or resonator (see Figure 4-8). CL1 and CL2 are typically the same size. Crystal manufacturers usually specify a load capacitance, which is the series combination of CL1 and CL2. When determining the size of CL1 and CL2, the PCB and MCU pin capacitance must be taken into account (10 pF can be used as a rough estimate for the combined pin and circuit board capacitance).

Figure 4-9 Typical application using an 8MHz crystal

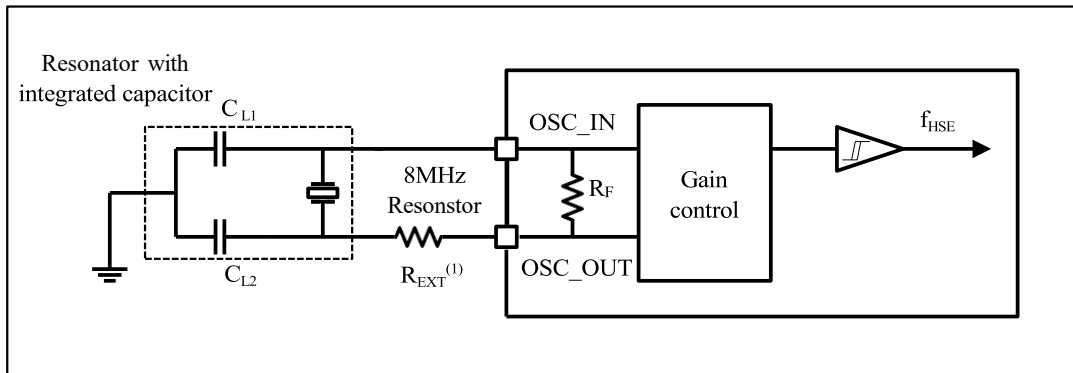

1. The value of R_{EXT} is determined by the characteristics of the crystal.

4.3.8.4 Low-Speed External Clock Source (External Crystal/Ceramic Resonator)

The low-speed external clock (LSE) can be generated using an oscillator consisting of a 32.768kHz crystal or ceramic resonator (crystal mode).

The information provided in this section is based on comprehensive characteristic evaluations using typical external components listed in the table below.

In applications, the resonator and load capacitors must be placed as close as possible to the oscillator pins to minimize output distortion and startup stabilization time.

For detailed parameters of the crystal resonator (such as frequency, package, accuracy, etc.), please consult the respective manufacturers.

(Note: The "crystal resonator" mentioned here refers to a standard passive crystal oscillator.)

Note: For CL1 and CL2, it is recommended to use high-quality ceramic capacitors and to select crystals or resonators that meet the required specifications. Typically, CL1 and CL2 have the same specifications.

Crystal manufacturers usually specify the load capacitance parameters based on the series combination of CL1 and CL2.

The load capacitance **CL** is calculated as follows:

$$C_L = C_{L1} \times C_{L2} / (C_{L1} + C_{L2}) + C_{stray}$$

is the stray capacitance associated with the pins and PCB (Printed Circuit Board).

Example:

If a resonator with a specified load capacitance $CL = 6pF$ is selected and $C_{stray} = 2pF$, then $CL1 = CL2 = 8pF$.

Table 4-17 LSE Oscillator Characteristics⁽¹⁾

| Symbol | Parameter | Conditions | Min | Typ | Max | Unit |
|-----------------------|-------------------------------------|------------------------------|-----|--------|-----|------------|
| f | Oscillator Frequency | - | - | 32.768 | - | KHz |
| R | Feedback Resistor | - | - | 100 | - | K Ω |
| IDD _{LSE} | LSE Drive Current | Low drive capability | - | 300 | - | nA |
| | | Medium-low drive capability | - | 400 | - | |
| | | Medium-high drive capability | - | 550 | - | |
| | | High drive capability | - | 1000 | - | |
| G _{meritmax} | Maximum Oscillator Transconductance | Low drive capability | - | - | 0.5 | uA/V |
| | | Medium-low drive capability | - | - | 1 | |
| | | Medium-high drive capability | - | - | 2 | |
| | | High drive capability | - | - | 3 | |
| t _{SU} | Startup Time | After VDD stabilizes | - | 2 | - | s |

1. Guaranteed by comprehensive evaluation, not tested in production.
2. **t_{SU} (LSE)** is the startup time measured from the moment LSE is enabled via software until a stable 32.768kHz oscillation is achieved. This value is measured with a standard crystal resonator and may vary significantly depending on the crystal manufacturer.

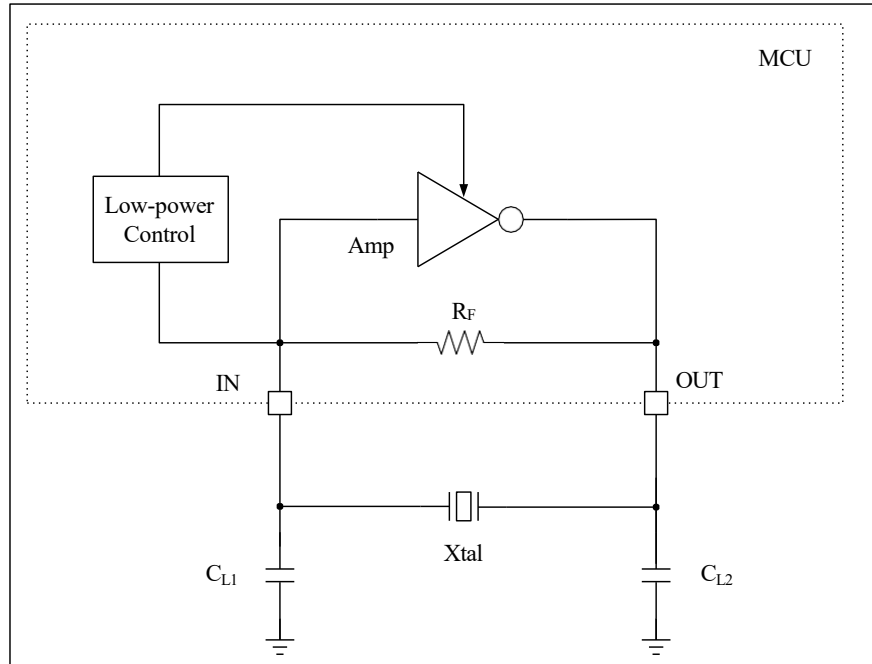
Figure 4-10 Typical Application Using a 32.768kHz Crystal

4.3.9 Internal Clock Source Characteristics

Table 4-18 HSI64 Oscillator Characteristics

4.3.9.1 64MHz High-Speed Internal Oscillator (HSI64)

Table 4-18 HSI64 Oscillator Characteristics

| Symbol | Parameter | Conditions | Min | Typ | Max | Unit |
|----------------------|----------------------------|--|-------|-------|-------|------|
| f_{HSI64} | Frequency | VDD=3.3V, T _J 25 degrees C, after calibration | 63.68 | 64 | 64.32 | MHz |
| TRIM | User calibration step size | - | - | 0.5 | - | % |
| USER TRIM COVERAGE | User calibration coverage | ± 32 steps | ±4.79 | ±5.60 | - | % |
| ACC _{HSI64} | HSI64 Oscillator Accuracy | VDD=3.3V, T _J = -40~125°C, including temperature drift and reflow effects | -2 | - | 2 | % |
| | | VDD=3.3V, T _J = -20~105°C, including temperature drift and reflow effects | -1.5 | - | 1.5 | % |

| | | | | | | |
|---------------------|---|--------------------|----|-------|------|---------|
| $\Delta VDD(HSI48)$ | HSI64 Oscillator frequency drift with VDD | VDD=3 to 3.6 V | - | 0.025 | 0.05 | % |
| | | VDD=2.3 V to 3.6 V | - | 0.05 | 0.1 | |
| $t_{SU(HSI64)}$ | HSI Oscillator startup time | - | 1 | 6 | 10 | μs |
| DuCy(HSI64) | Duty cycle | - | 45 | 50 | 55 | % |
| $I_{DD(HSI64)}$ | HSI Oscillator power consumption | - | - | 250 | 350 | μA |
| N_T jitter | Next transition jitter (accumulated over 28 cycles) | - | - | TBD | - | μs |
| P_T jitter | Paired transition jitter (accumulated over 56 cycles) | - | - | TBD | - | μs |

4.3.9.2 Multi-Speed Internal Oscillator (MSI)

Table 4-19 MSI Oscillator Characteristics

| Symbol | Parameter | Conditions | Mn | Typ | Max | Unit |
|--------------------|----------------------------------|--|-------|-------|-------|---------|
| f_{MSI} | Frequency | VDD = 3.3V, T _{Js} = 25°C, after calibration, default MSI = 16MHz | 15.84 | 16 | 16.16 | MHz |
| TRIM | User calibration step size | - | - | 0.175 | - | % |
| USER TRIM COVERAGE | User calibration coverage | ± 32 steps | ±4.79 | ±5.60 | - | % |
| ACC_{MSI} | MSI Oscillator Accuracy | VDD = 3.3V, T _J = -40~125°C, including temperature drift and reflow effects | -2 | - | 2 | % |
| | | VDD = 3.3V, T _J = -20~105°C, including temperature drift and reflow effects | -1.5 | - | 1.5 | % |
| $t_{SU(MSI)}$ | MSI Oscillator startup time | - | - | 4 | 6 | μs |
| DuCy(MSI) | Duty cycle | - | 45 | 50 | 55 | % |
| $I_{DD(MSI)}$ | MSI Oscillator power consumption | - | - | 150 | 200 | μA |

4.3.9.3 Low-Speed Internal Oscillator (LSI)

Table 4-20 LSI Oscillator Characteristics

| Symbol | Parameter | Conditions | Min | Typ | Max | Unit |
|---------------------|--|---|-------|-----|-------|------|
| $f_{LSI}^{(2)}$ | Output frequency | 25°C calibration, VDD = 3.3V | 31.36 | 32 | 32.64 | KHz |
| | | VDD = 1.8V ~ 3.6V, T _J = -40~105°C | 30.4 | 32 | 33.6 | KHz |
| $t_{SU(LSI)}^{(3)}$ | LSI Oscillator startup time | - | - | 30 | 80 | μs |
| $t_{stab(LSI)}$ | LSI Oscillator stabilization time (within 5% of final value) | - | - | - | - | - |
| $I_{DD(LSI)}^{(3)}$ | LSI Oscillator power consumption | - | - | 1.2 | 2.4 | μA |

4.3.10 Wake-up Time from Low-Power Modes

Table 4-21 Wake-up Times for Low-Power Modes

Table 4-21 Wake-up Times for Low-Power Modes

| Symbol | Parameter | Typical Value (1) | Unit |
|---------------|---------------------------|----------------------|--------|
| $t_{WUSLEEP}$ | Wake-up from Sleep mode | TBD | Cycles |
| $t_{WUSTOP0}$ | Wake-up from Stop 0 mode | TBD | μs |
| | Wake-up from Stop 2 mode | TBD | μs |
| $t_{WUSTDBY}$ | Wake-up from Standby mode | TBD | μs |

4.3.11 PLL Characteristics

The parameters listed in Table 4-19 and Table 4-21 were measured under ambient temperature (25°C) and supply voltage conditions as specified in Table 4-4.

4.3.11.1 PLL1/2/3 Characteristics

Table 4-22 PLL Characteristics

| Symbol | Parameter | Value | | | Unit |
|----------------|-----------------------------|-------|-----|--------------------|------|
| | | Min | Typ | Max ⁽¹⁾ | |
| f_{PLL_IN} | PLL input clock (2) | 8 | 25 | 64 | MHz |
| | PLL input clock duty cycle | 40 | 50 | 60 | % |
| f_{PLL_OUT} | PLL multiplied output clock | 440 | - | 800 | MHz |

| | | | | | |
|----------------|---|-----|---------|-----|---------|
| t_{LOCK} | PLL Ready signal output time | - | - | 150 | μ s |
| Jitter | Rms cycle-to-cycle jitter @800MHz | - | ± 4 | - | ps |
| f_{VCO_OUT} | PLL VCO output | 440 | - | 800 | MHz |
| I_{PLL} | Operating Current of PLL @200MHz VCO frequency. | - | 3 | - | μ A |

1. Obtained from characterization; not tested in production.
2. Care must be taken to use the correct multiplication factor so that the f_{PLL_OUT} remains within the allowed range according to the PLL input clock frequency.

4.3.11.2 SHRPLL Characteristics

Table 4-23 SHRPLL Characteristics

| Symbol | Parameter | Value | | | Unit |
|-------------------|---|-------|---------|--------------------|----------|
| | | Min | Typ | Max ⁽¹⁾ | |
| f_{SHRPLL_IN} | SHRPLL input clock ⁽²⁾ | 8 | 25 | 64 | MHz |
| | SHRPLL input clock duty cycle | 40 | 50 | 60 | % |
| f_{SHRPLL_OUT} | SHRPLL multiplied output clock | 440 | - | 1250 | MHz |
| t_{LOCK} | SHRPLL Ready signal output time | 10 | 62.5 | 125 | μ s |
| Jitter | Rms period jitter @1250MHz | - | ± 2 | - | \pm ps |
| I_{SHRPLL} | Operating Current of SHRPLL @1250MHz VCO frequency. | - | 6 | - | mA |

1. Results based on comprehensive evaluation, not tested in production.
2. Attention must be paid to using the correct multiplication factor to ensure that the f_{SHRPLL_OUT} falls within the permissible range based on the input clock frequency.

4.3.12 Absolute Maximum Ratings (Electrical Sensitivity)

Based on different tests (ESD, LU), specific measurement methods are used to evaluate the chip's performance regarding electrical sensitivity.

Electrostatic Discharge (ESD)

An electrostatic discharge (one positive pulse followed by one negative pulse after one second) is applied to all pins of all samples.

Table 4-24 ESD Absolute Maximum Ratings

| Symbol | Parameter | Conditions | Type | Max ⁽¹⁾ | Unit |
|----------------|------------------------------------|--|------|--------------------|------|
| $V_{ESD(HBM)}$ | ESD Voltage (Human Body Model) | TA = +25°C, per MIL-STD-883K Method 3015.9 | 3A | 2000 | V |
| $V_{ESD(CDM)}$ | ESD Voltage (Charged Device Model) | TA = +25°C, per ESDA/JEDEC JS-002-2018 | C3 | 200 | |

- Results based on comprehensive evaluation, not tested in production.

Latch-Up (LU)

To evaluate latch-up performance, two complementary static latch-up tests are performed on six samples:

- Provide an over-limit supply voltage to each power pin.
- Inject current into each input, output, and configurable I/O pin.

This test complies with EIA/JESD78A IC latch-up standard.

Table 4-22 Static Latch-Up

| Symbol | Parameter | Conditions | Type | Min ⁽¹⁾ |
|--------|-----------------------|--------------------------------------|------------|--------------------|
| LU | Static Latch-Up Class | T _A = +105°C, perJESD 78E | Class II A | ±200mA, 1.5*VDDMAX |

- Tested under room temperature conditions.

4.3.13 I/O Port Characteristics

General Input/Output Characteristics

Unless otherwise specified, parameters listed below are measured under the conditions in Table 4-4. All I/O ports are CMOS and TTL compatible.

Table 4-26 I/O Static Characteristics

| Symbol | Parameter | Conditions | Min | Typ | Max | Unit |
|------------------|---|--|---------------------|-----|---------------------|------|
| V _{IL} | Input low level voltage | V _{DD} =3.3V | 2 | - | V _{DD} | V |
| | | V _{DD} =2.5V | 1.7 | - | V _{DD} | |
| | | V _{DD} =1.8V | 0.7 V _{DD} | - | V _{DD} | |
| V _{IH} | Input high level voltage | V _{DD} =3.3V | V _{SS} | - | 0.8 | V |
| | | V _{DD} =2.5V | V _{SS} | - | 0.7 | |
| | | V _{DD} =1.8V | V _{SS} | - | 0.3 V _{DD} | |
| V _{hys} | Schmitt trigger hysteresis voltage ⁽¹⁾ | V _{DD} =3.3V | 200 | - | - | mV |
| | | V _{DD} =2.5V | 165 | - | - | |
| | | V _{DD} =1.8V | 165 | - | - | |
| I _{lkg} | Input leakage current ⁽³⁾ | V _{DD} =Maximum | -5 | - | 5 | μA |
| | | V _{PAD} =0 或 V _{PAD} =V _{DD} ⁽³⁾ | | | | |
| R _{PU} | Weak pull-up equivalent resistance ⁽⁴⁾ | V _{DD} =3.3v, V _{IN} = V _{SS} | 16 | - | 61.4 | kΩ |
| | | V _{DD} =1.8~3.3v, V _{IN} = V _{SS} | 16 | - | 142.6 | kΩ |
| R _{PD} | Weak pull-down equivalent resistance ⁽⁴⁾ | V _{DD} =3.3v, V _{IN} = V _{DD} | 16 | - | 61.4 | kΩ |
| | | V _{DD} =1.8~3.3v, V _{IN} = V _{DD} | 16 | - | 142.6 | kΩ |
| C _{IO} | I/O pin capacitance | - | - | 5 | - | pF |

1. Schmitt trigger hysteresis voltage at switching level. Results based on evaluation, not tested in production.
2. At least 100mV.
3. If there is reverse current injection between adjacent pins, leakage current may exceed the maximum value.
4. Pull-up and pull-down resistors are implemented via switchable PMOS/NMOS.
5. VPAD refers to the I/O pin input voltage.

All I/O ports are **CMOS and TTL compatible** (no software configuration required). Their characteristics consider stringent CMOS process or TTL parameters:

Output Drive Current

GPIO (General Purpose I/O ports) can sink or source up to $\pm 12\text{mA}$ of current. In user applications, the number of I/O pins must ensure that the drive current does not exceed the absolute maximum ratings defined in Section 4.2:

- The total current drawn from VDD by all I/O ports plus the MCU's maximum operating current must not exceed IVDD (Table 4-2).
- The total current sunk into VSS by all I/O ports plus the MCU's maximum current sourced to VSS must not exceed IVSS (Table 4-2).

Output Voltage

Unless otherwise specified, parameters in Table 4-27 are measured at room temperature (25°C) and under supply voltages per Table 4-4. All I/O ports are CMOS and TTL compatible.

Table 4-27 FT IO Drive Capability Table⁽¹⁾

| Drive Level | I _{OH} , VDD=3.3V | I _{OL} , VDD=3.3V | I _{OH} , VDD=2.5V | I _{OL} , VDD=2.5V | I _{OH} , VDD=1.8V | I _{OL} , VDD=1.8V | Unit |
|-------------|-------------------------------|-------------------------------|-------------------------------|-------------------------------|-------------------------------|-------------------------------|------|
| 2 | 2.7 | 3.3 | TBD | TBD | 1.4 | 1.5 | mA |
| 4 | 5.7 | 6.6 | TBD | TBD | 3 | 3.1 | mA |
| 8 | 11.2 | 13.3 | TBD | TBD | 6 | 6.3 | mA |
| 12 | 16.8 | 19.9 | TBD | TBD | 9 | 9.5 | mA |

1. Guaranteed by design, not tested in production

Table 4-28 TC IO Drive Capability Table⁽¹⁾

| Drive Level | I _{OH} , VDD=3.3V | I _{OL} , VDD=3.3V | I _{OH} , VDD=2.5V | I _{OL} , VDD=2.5V | I _{OH} , VDD=1.8V | I _{OL} , VDD=1.8V | Unit |
|-------------|-------------------------------|-------------------------------|-------------------------------|-------------------------------|-------------------------------|-------------------------------|------|
| 2 | 8.1 | 6.1 | 3.1 | 4.5 | 2.6 | 3.8 | mA |
| 4 | 16.2 | 12.2 | 6.2 | 9.1 | 3 | 3.1 | mA |
| 8 | 28.3 | 21.4 | 10.9 | 16 | 9.2 | 13.1 | mA |
| 12 | 44.1 | 33.5 | 17.2 | 25.2 | 14.5 | 19.9 | mA |

1. Guaranteed by design, not tested in production.

Table 4-29 Output Voltage Characteristics⁽³⁾

| Symbol | Parameter | Conditions | Min | Max | Unit |
|--------|-----------|------------|-----|-----|------|
|--------|-----------|------------|-----|-----|------|

| | | | | | |
|--------------------------------|---------------------------|--|---------------------|----------------------|---|
| V _{OL} ⁽¹⁾ | Output low level voltage | V _{DD} =3.3V, I _{OL} ⁽⁴⁾ = 2/4/8/12 | VSS | 0.4 | V |
| | | V _{DD} =2.5V, I _{OL} ⁽⁴⁾ = 2/4/8/12 | VSS | 0.4 | |
| | | V _{DD} =1.8V, I _{OL} ⁽⁴⁾ = 2/4/8/12 | VSS | 0.2* V _{DD} | |
| V _{OH} ⁽²⁾ | Output high level voltage | V _{DD} =3.3V, I _{OH} ⁽⁴⁾ = 2/4/8/12 | 2.4 | V _{DD} | |
| | | V _{DD} =2.5V, I _{OH} ⁽⁴⁾ = 2/4/8/12 | 2 | V _{DD} | |
| | | V _{DD} =1.8V, I _{OH} ⁽⁴⁾ = 2/4/8/12 | 0.8*V _{DD} | V _{DD} | |

1. IIO current drawn by the chip must comply with the absolute maximum ratings in Table 4-2. Total IIO for all I/O and control pins must not exceed IVSS.
2. IIO current output by the chip must comply with absolute maximum ratings. Total IIO must not exceed IVDD.
3. Results based on evaluation, not tested in production.
4. Actual drive capability, see Table 4-25.
5. PC13, PC14, and PC15 are excluded.

Output Buffer Timing Characteristics

Unless otherwise specified, the parameters listed in Tables 4-28 and 4-29 are measured at 25°C and under supply voltages per Table 4-4.

Table 4-30 Output Timing Characteristics (TC IO) ⁽¹⁾

| PMODE | Symbol | Parameter | Conditions | Min | Max | Unit |
|-------|---|---|--|-----|------|------|
| 00 | F _{max} ⁽²⁾ | Maximum Frequency | C=50 pF, 2.7 V ≤ V _{DD} ≤ 3.6 V | - | 19 | MHz |
| | | | C=50 pF, 2.3 V ≤ V _{DD} ≤ 2.7 V | - | 10 | |
| | | | C=30 pF, 2.7 V ≤ V _{DD} ≤ 3.6 V | - | 31 | |
| | | | C=30 pF, 2.3 V ≤ V _{DD} ≤ 2.7 V | - | 16 | |
| | | | C=10 pF, 2.7 V ≤ V _{DD} ≤ 3.6 V | - | 84 | |
| | | | C=10 pF, 2.3 V ≤ V _{DD} ≤ 2.7 V | - | 48 | |
| | t _r /t _f ⁽³⁾ | Fall time from high level to low level and rise time from low level to high level | C=50 pF, 2.7 V ≤ V _{DD} ≤ 3.6 V | - | 17.9 | ns |
| | | | C=50 pF, 2.3 V ≤ V _{DD} ≤ 2.7 V | - | 33.5 | |
| | | | C=30 pF, 2.7 V ≤ V _{DD} ≤ 3.6 V | - | 11 | |
| | | | C=30 pF, 2.3 V ≤ V _{DD} ≤ 2.7 V | - | 20.6 | |
| | | | C=10 pF, 2.7 V ≤ V _{DD} ≤ 3.6 V | - | 4.1 | |
| | | | C=10 pF, 2.3 V ≤ V _{DD} ≤ 2.7 V | - | 7.7 | |
| 01 | F _{max} ⁽²⁾ | Maximum frequency | C=50 pF, 2.7 V ≤ V _{DD} ≤ 3.6 V | - | 51 | MHz |
| | | | C=50 pF, 2.3 V ≤ V _{DD} ≤ 2.7 V | - | 32 | |
| | | | C=30 pF, 2.7 V ≤ V _{DD} ≤ 3.6 V | - | 85 | |
| | | | C=30 pF, 2.3 V ≤ V _{DD} ≤ 2.7 V | - | 45 | |
| | | | C=10 pF, 2.7 V ≤ V _{DD} ≤ 3.6 V | - | 222 | |
| | | | C=10 pF, 2.3 V ≤ V _{DD} ≤ 2.7 V | - | 118 | |
| | t _r /t _f ⁽³⁾ | | C=50 pF, 2.7 V ≤ V _{DD} ≤ 3.6 V | - | 6.6 | ns |

| | | | | | | |
|----|---|--|---|---|-------|-----|
| | | | C=50 pF, 2.3 V ≤ V _{DD} ≤ 2.7 V | - | 9.9 | |
| | | | C=30 pF, 2.7 V ≤ V _{DD} ≤ 3.6 V | - | 4.1 | |
| | | Fall time from high level to low level and rise time from low level to high level | C=30 pF, 2.3 V ≤ V _{DD} ≤ 2.7 V | - | 7.7 | |
| | | | C=10 pF, 2.7 V ≤ V _{DD} ≤ 3.6 V | - | 1.7 | |
| | | | C=10 pF, 2.3 V ≤ V _{DD} ≤ 2.7 V | - | 3.1 | |
| 10 | F _{max} ⁽²⁾ | Maximum frequency | C=50 pF, 2.7 V ≤ V _{DD} ≤ 3.6 V ⁽⁴⁾ | - | 87 | MHz |
| | | | C=50 pF, 2.3 V ≤ V _{DD} ≤ 2.7 V ⁽⁴⁾ | - | 46 | |
| | | | C=30 pF, 2.7 V ≤ V _{DD} ≤ 3.6 V ⁽⁴⁾ | - | 143 | |
| | | | C=30 pF, 2.3 V ≤ V _{DD} ≤ 2.7 V ⁽⁴⁾ | - | 75 | |
| | | | C=10 pF, 2.7 V ≤ V _{DD} ≤ 3.6 V ⁽⁴⁾ | - | 339 | |
| | | | C=10 pF, 2.3 V ≤ V _{DD} ≤ 2.7 V ⁽⁴⁾ | - | 185 | |
| | t _r /t _f ⁽³⁾ | Fall time from high level to low level and rise time from low level to high level | C=50 pF, 2.7 V ≤ V _{DD} ≤ 3.6 V ⁽⁴⁾ | - | 3.92 | ns |
| | | | C=50 pF, 2.3 V ≤ V _{DD} ≤ 2.7 V ⁽⁴⁾ | - | 7.52 | |
| | | | C=30 pF, 2.7 V ≤ V _{DD} ≤ 3.6 V ⁽⁴⁾ | - | 2.41 | |
| | | | C=30 pF, 2.3 V ≤ V _{DD} ≤ 2.7 V ⁽⁴⁾ | - | 4.61 | |
| | | | C=10 pF, 2.7 V ≤ V _{DD} ≤ 3.6 V ⁽⁴⁾ | - | 1.06 | |
| | | | C=10 pF, 2.3 V ≤ V _{DD} ≤ 2.7 V ^v | - | 1.98 | |
| 11 | F _{max} ⁽²⁾ | Maximum frequency | C=50 pF, 2.7 V ≤ V _{DD} ≤ 3.6 V ^v | - | 138 | MHz |
| | | | C=50 pF, 2.3 V ≤ V _{DD} ≤ 2.7 V ⁽⁴⁾ | - | 69 | |
| | | | C=30 pF, 2.7 V ≤ V _{DD} ≤ 3.6 V ^v | - | 215 | |
| | | | C=30 pF, 2.3 V ≤ V _{DD} ≤ 2.7 V ⁽⁴⁾ | - | 122 | |
| | | | C=10 pF, 2.7 V ≤ V _{DD} ≤ 3.6 V ⁽⁴⁾ | - | 467 | |
| | | | C=10 pF, 2.3 V ≤ V _{DD} ≤ 2.7 V ⁽⁴⁾ | - | 260 | |
| | t _r /t _f ⁽³⁾ | Fall time from high level to low level and rise time from low level to high level. | C=50 pF, 2.7 V ≤ V _{DD} ≤ 3.6 V ⁽⁴⁾ | - | 2.52 | ns |
| | | | C=50 pF, 2.3 V ≤ V _{DD} ≤ 2.7 V ⁽⁴⁾ | - | 5.05 | |
| | | | C=30 pF, 2.7 V ≤ V _{DD} ≤ 3.6 V ⁽⁴⁾ | - | 1.6 | |
| | | | C=30 pF, 2.3 V ≤ V _{DD} ≤ 2.7 V ⁽⁴⁾ | - | 2.9 | |
| | | | C=10 pF, 2.7 V ≤ V _{DD} ≤ 3.6 V ⁽⁴⁾ | - | 0.77 | |
| | | | C=10 pF, 2.3 V ≤ V _{DD} ≤ 2.7 V ⁽⁴⁾ | - | 1.385 | |

- Design guaranteed.
- The definition conditions for the maximum frequency are as follows:
 $(t_r + t_f) \leq 2/3 T$
 Skew $\leq 1/20 T$
 45% < Duty Cycle < 55%
- The fall time and rise time are defined respectively as the time between 90% and 10% of the output waveform, and between 10% and 90%.
- Compensation system enabled.

Table 4-31 Output Timing Characteristics (FT IO) ⁽¹⁾

| PMODE | Symbol | Parameter | Conditions | Min | Max | Unit |
|------------|---|---|---|-----|------|------|
| 00 Fast | F _{max} ⁽²⁾ | Maximum Frequency | C=50 pF, 2.7 V ≤ V _{DD} ≤ 3.6 V | - | 13 | MHz |
| | | | C=50 pF, 2.3 V ≤ V _{DD} ≤ 2.7 V | - | 6 | |
| | | | C=30 pF, 2.7 V ≤ V _{DD} ≤ 3.6 V | - | 20 | |
| | | | C=30 pF, 2.3 V ≤ V _{DD} ≤ 2.7 V | - | 10 | |
| | | | C=10 pF, 2.7 V ≤ V _{DD} ≤ 3.6 V | - | 46 | |
| | | | C=10 pF, 2.3 V ≤ V _{DD} ≤ 2.7 V | - | 24 | |
| | t _r /t _f ⁽³⁾ | Fall time from high to low and rise time from low to high | C=50 pF, 2.7 V ≤ V _{DD} ≤ 3.6 V | - | 26.4 | ns |
| | | | C=50 pF, 2.3 V ≤ V _{DD} ≤ 2.7 V | - | 48.8 | |
| | | | C=30 pF, 2.7 V ≤ V _{DD} ≤ 3.6 V | - | 17 | |
| | | | C=30 pF, 2.3 V ≤ V _{DD} ≤ 2.7 V | - | 31.1 | |
| | | | C=10 pF, 2.7 V ≤ V _{DD} ≤ 3.6 V | - | 7.7 | |
| | | | C=10 pF, 2.3 V ≤ V _{DD} ≤ 2.7 V | - | 13.6 | |
| 01 Fast | F _{max} ⁽²⁾ | Maximum Frequency | C=50 pF, 2.7 V ≤ V _{DD} ≤ 3.6 V | - | 26 | MHz |
| | | | C=50 pF, 2.3 V ≤ V _{DD} ≤ 2.7 V | - | 13 | |
| | | | C=30 pF, 2.7 V ≤ V _{DD} ≤ 3.6 V | - | 40 | |
| | | | C=30 pF, 2.3 V ≤ V _{DD} ≤ 2.7 V | - | 21 | |
| | | | C=10 pF, 2.7 V ≤ V _{DD} ≤ 3.6 V | - | 86 | |
| | | | C=10 pF, 2.3 V ≤ V _{DD} ≤ 2.7 V | - | 46 | |
| | t _r /t _f ⁽³⁾ | Fall time from high to low and rise time from low to high | C=50 pF, 2.7 V ≤ V _{DD} ≤ 3.6 V | - | 13.2 | ns |
| | | | C=50 pF, 2.3 V ≤ V _{DD} ≤ 2.7 V | - | 24.8 | |
| | | | C=30 pF, 2.7 V ≤ V _{DD} ≤ 3.6 V | - | 8.6 | |
| | | | C=30 pF, 2.3 V ≤ V _{DD} ≤ 2.7 V | - | 16.1 | |
| | | | C=10 pF, 2.7 V ≤ V _{DD} ≤ 3.6 V | - | 4 | |
| | | | C=10 pF, 2.3 V ≤ V _{DD} ≤ 2.7 V | - | 7.3 | |
| 10 | F _{max} ⁽²⁾ | Maximum frequency | C=50 pF, 2.7 V ≤ V _{DD} ≤ 3.6 V ⁽⁴⁾ | - | 50 | MHz |
| | | | C=50 pF, 2.3 V ≤ V _{DD} ≤ 2.7 V ⁽⁴⁾ | - | 36 | |
| | | | C=30 pF, 2.7 V ≤ V _{DD} ≤ 3.6 V ⁽⁴⁾ | - | 75 | |
| | | | C=30 pF, 2.3 V ≤ V _{DD} ≤ 2.7 V ⁽⁴⁾ | - | 39 | |
| | | | C=10 pF, 2.7 V ≤ V _{DD} ≤ 3.6 V ⁽⁴⁾ | - | 151 | |
| | | | C=10 pF, 2.3 V ≤ V _{DD} ≤ 2.7 V ⁽⁴⁾ | - | 83 | |
| | t _r /t _f ⁽³⁾ | Fall time from high to low and rise time from low to high | C=50 pF, 2.7 V ≤ V _{DD} ≤ 3.6 V ⁽⁴⁾ | - | 6.97 | ns |
| | | | C=50 pF, 2.3 V ≤ V _{DD} ≤ 2.7 V ⁽⁴⁾ | - | 9.65 | |
| | | | C=30 pF, 2.7 V ≤ V _{DD} ≤ 3.6 V ⁽⁴⁾ | - | 4.66 | |
| | | | C=30 pF, 2.3 V ≤ V _{DD} ≤ 2.7 V ⁽⁴⁾ | - | 8.4 | |
| | | | C=10 pF, 2.7 V ≤ V _{DD} ≤ 3.6 V ⁽⁴⁾ | - | 2.26 | |
| | | | C=10 pF, 2.3 V ≤ V _{DD} ≤ 2.7 V ^v | - | 4 | |

| | | | | | | |
|------------|---|---|---|---|------|-----|
| 11 Fast | Fmax ⁽²⁾ | Maximum frequency | C=50 pF, 2.7 V ≤ V _{DD} ≤ 3.6 V ^v | - | 72 | MHz |
| | | | C=50 pF, 2.3 V ≤ V _{DD} ≤ 2.7 V ⁽⁴⁾ | - | 38 | |
| | | | C=30 pF, 2.7 V ≤ V _{DD} ≤ 3.6 V ^v | - | 106 | |
| | | | C=30 pF, 2.3 V ≤ V _{DD} ≤ 2.7 V ⁽⁴⁾ | - | 56 | |
| | | | C=10 pF, 2.7 V ≤ V _{DD} ≤ 3.6 V ⁽⁴⁾ | - | 202 | |
| | | | C=10 pF, 2.3 V ≤ V _{DD} ≤ 2.7 V ⁽⁴⁾ | - | 113 | |
| | t _r /t _f ⁽³⁾ | Fall time from high to low and rise time from low to high | C=50 pF, 2.7 V ≤ V _{DD} ≤ 3.6 V ⁽⁴⁾ | - | 4.82 | ns |
| | | | C=50 pF, 2.3 V ≤ V _{DD} ≤ 2.7 V ⁽⁴⁾ | - | 8.9 | |
| | | | C=30 pF, 2.7 V ≤ V _{DD} ≤ 3.6 V ⁽⁴⁾ | - | 3.28 | |
| | | | C=30 pF, 2.3 V ≤ V _{DD} ≤ 2.7 V ⁽⁴⁾ | - | 5.93 | |
| | | | C=10 pF, 2.7 V ≤ V _{DD} ≤ 3.6 V ⁽⁴⁾ | - | 1.65 | |
| | | | C=10 pF, 2.3 V ≤ V _{DD} ≤ 2.7 V ⁽⁴⁾ | - | 2.98 | |

1. Design guarantee.
2. The definition conditions for the maximum frequency are as follows:
 $(t_r + t_f) \leq 2/3 T$
 Skew $\leq 1/20 T$
 $45\% < \text{Duty Cycle} < 55\%$
3. The fall time and rise time are defined as the time between 90% and 10% of the output waveform, and between 10% and 90% of the waveform, respectively.
4. Enable compensation system.

Figure 4-11: Definition of Input/Output AC Characteristics

Figure 4-12 Transmission Delay

4.3.14 NRST Pin Characteristics

The NRST pin input drive uses CMOS technology, and an internal non-removable pull-up resistor, RPU (see Table 4-30), is integrated. Unless otherwise specified, the parameters listed in Table 4-30 are measured under conditions where the ambient temperature is 25°C, and the supply voltage meets the conditions specified in Table 4-4.

Table 4-32: NRST Pin Characteristics

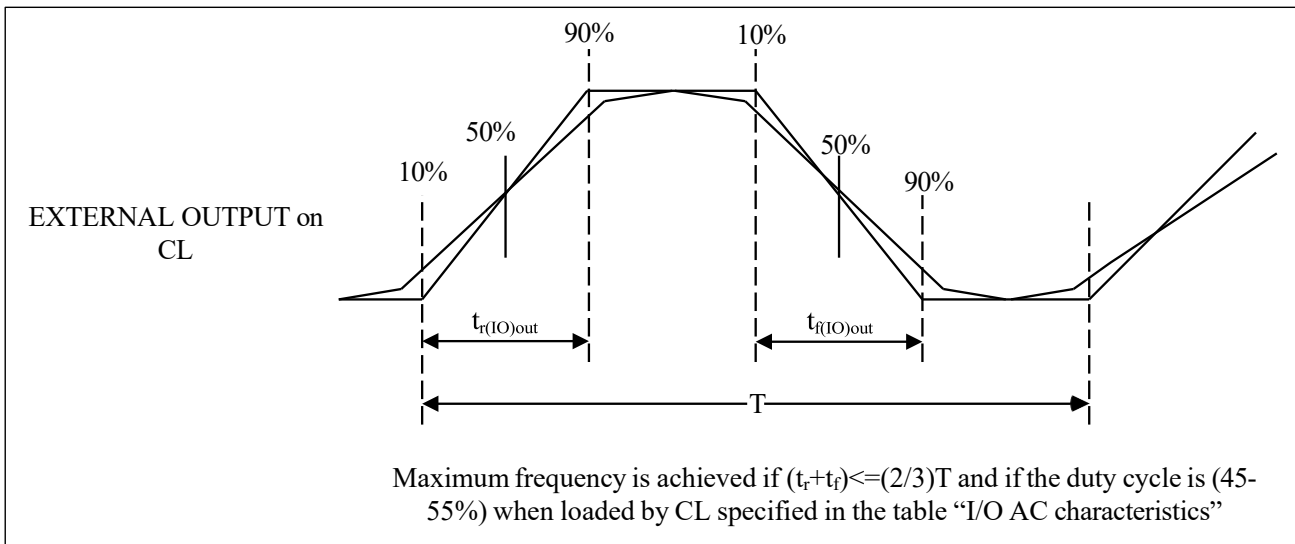
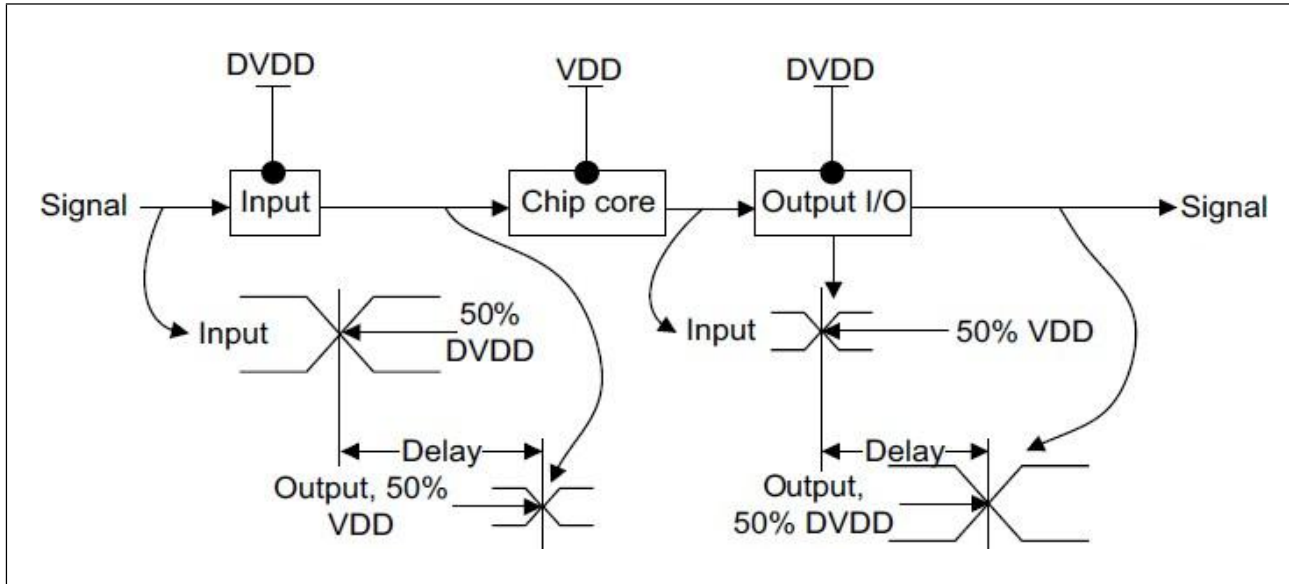
| Symbol | Parameter | Condition | Min | Typ | Max | Unit |
|----------------------|---|-------------------|----------------|-----|----------------|------------|
| $V_{IL(NRST)}^{(1)}$ | NRST Input Low Voltage | - | VSS | - | $0.3 * V_{DD}$ | V |
| $V_{IH(NRST)}^{(1)}$ | NRST Input High Voltage | - | $0.7 * V_{DD}$ | - | V_{DD} | |
| $V_{hys(NRST)}$ | NRST Schmitt Trigger Hysteresis | - | 200 | - | - | mV |
| R_{PU} | Weak Pull-up Equivalent Resistance ⁽²⁾ | $V_{IN} = V_{SS}$ | 30 | 50 | 70 | k Ω |
| $V_{F(NRST)}^{(1)}$ | NRST Input Filtered Pulse | $V_{DD} = 3.3V$ | - | - | 100 | ns |
| $V_{NF(NRST)}^{(1)}$ | NRST Input Non-Filtered Pulse | $V_{DD} = 3.3V$ | 300 | - | - | ns |

1. Guaranteed by design, not tested during production.
2. The pull-up resistor is designed as a true resistor in series with a switchable PMOS. The resistance of the PMOS/NMOS switch is very small (about 10%).

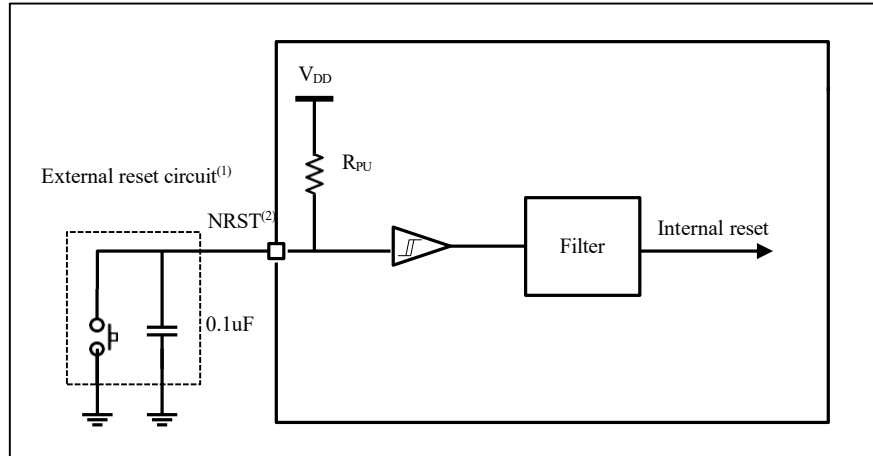
Figure 4-13: Recommended NRST Pin Protection

1. 滤波作用。
2. 用户必须保证NRST引脚的电位能够低于 中列出的最大VIL(NRST)以下，否则MCU不能得到复位。

4.3.15 TIM Timer Characteristics

The parameters listed in Tables 4-31, 4-32, 4-33, and 4-34 are guaranteed by design.

For details on the characteristics of input/output multiplexing function pins (output compare, input capture, external clock, PWM output), please refer to section 4.3.12.

Table 4-33: ATIM1/2/3/4 Characteristics ⁽¹⁾

| Symbol | Parameter | Condition | Min | Max | Unit |
|------------------------|---|-------------------------------|---------|-------------------------|----------------------|
| t _{res(TIM)} | Timer Resolution Time | - | 1 | - | t _{TIMxCLK} |
| | | f _{TIMxCLK} = 300MHz | 3.33 | - | ns |
| f _{EXT} | External Clock Frequency for CH1 to CH4 | - | 0 | f _{TIMxCLK} /2 | MHz |
| | | f _{TIMxCLK} = 300MHz | 0 | 150 | MHz |
| Res _{TIM} | Timer Resolution | - | - | 16 | bit |
| t _{COUNTER} | 16-bit Counter Clock Cycle (Internal Clock) | - | 1 | 65536 | t _{TIMxCLK} |
| | | f _{TIMxCLK} = 300MHz | 0.00333 | 218 | μs |
| t _{MAX_COUNT} | Maximum Possible Count | - | - | 65536x65536 | t _{TIMxCLK} |
| | | f _{TIMxCLK} = 300MHz | - | 14.3 | s |

1. Guaranteed by design, not tested during production.

Table 4-34: GTIMA1/2/3/4/5/6/7 Characteristics ⁽¹⁾

| Symbol | Parameter | Condition | Min | Max | Unit |
|-----------------------|---|-------------------------------|------|-------------------------|----------------------|
| t _{res(TIM)} | Timer Resolution Time | - | 1 | - | t _{TIMxCLK} |
| | | f _{TIMxCLK} = 300MHz | 3.33 | - | ns |
| f _{EXT} | External Clock Frequency for CH1 to CH4 | - | 0 | f _{TIMxCLK} /2 | MHz |
| | | f _{TIMxCLK} = 300MHz | 0 | 150 | MHz |
| Res _{TIM} | | - | - | 16 | bit |

| | | | | | |
|------------------------|---|-------------------------------|---------|-------------|----------------------|
| | Timer Resolution | | | | |
| t _{COUNTER} | 16-bit Counter Clock Cycle (Internal Clock) | - | 1 | 65536 | t _{TIMxCLK} |
| | | f _{TIMxCLK} = 300MHz | 0.00333 | 218 | µs |
| t _{MAX_COUNT} | Maximum Possible Count | - | - | 65536x65536 | t _{TIMxCLK} |
| | | f _{TIMxCLK} = 300MHz | - | 14.3 | s |

1. Guaranteed by design, not tested during production.

Table 4-35: GTIMB1/2/3 Characteristics ⁽¹⁾

| Symbol | Parameter | Condition | Min | Max | Unit |
|------------------------|---|-------------------------------|---------|-------------------------|----------------------|
| t _{res(TIM)} | Timer Resolution Time | - | 1 | - | t _{TIMxCLK} |
| | | f _{TIMxCLK} = 300MHz | 3.33 | - | ns |
| f _{EXT} | External Clock Frequency for CH1 to CH4 | - | 0 | f _{TIMxCLK} /2 | MHz |
| | | f _{TIMxCLK} = 300MHz | 0 | 150 | MHz |
| Re _{TIM} | External Clock Frequency for CH1 to CH4 | - | - | 16 | bit |
| t _{COUNTER} | 16-bit Counter Clock Cycle (Internal Clock) | - | 1 | 65536 | t _{TIMxCLK} |
| | | f _{TIMxCLK} = 300MHz | 0.00333 | 218 | µs |
| t _{MAX_COUNT} | Maximum Possible Count | - | - | 65536x65536 | t _{TIMxCLK} |
| | | f _{TIMxCLK} = 300MHz | - | 14.3 | s |

1. Guaranteed by design, not tested during production.

Table 4-36: LPTIM1/2/3/4/5 Characteristics ⁽¹⁾

| Symbol | Parameter | Condition | Min | Max | Unit |
|------------------------|---|-------------------------------|---------|-------------------------|----------------------|
| t _{res(TIM)} | Timer Resolution Time | - | 1 | - | t _{TIMxCLK} |
| | | f _{TIMxCLK} = 150MHz | 6.67 | - | ns |
| f _{EXT} | External Clock Frequency for CH1 to CH4 | - | 0 | f _{TIMxCLK} /2 | MHz |
| | | f _{TIMxCLK} = 150MHz | 0 | 75 | MHz |
| Re _{TIM} | Timer Resolution | - | - | 16 | bit |
| t _{COUNTER} | 16-bit Counter Clock Cycle (Internal Clock) | - | 1 | 65536 | t _{TIMxCLK} |
| | | f _{TIMxCLK} = 150MHz | 0.00667 | 437 | µs |
| t _{MAX_COUNT} | Maximum Possible Count | - | - | 128x65536 | t _{TIMxCLK} |
| | | f _{TIMxCLK} = 150MHz | - | 55.9 | ms |

1. Guaranteed by design, not tested during production.

4.3.16 SHRTIM Timer Characteristics

Unless specifically stated, the parameters listed in Table 4-37 are measured under the environmental temperature and supply voltage conditions as specified in Table 4-4.

Table 4-37 SHRTIM Characteristics (1)

| Symbol | Parameter | Condition | Min | Typical | Max | Unit |
|--------------|--|---|-------|---------|----------------------------------|---------|
| TA | Timer Environmental Temperature Range | fSHRTIM = 250 MHz | -40 | - | 105 | °C |
| fSHRTIM | SHRTIM Input Clock for PLL Calibration | As per TA conditions | - | - | 250 | MHz |
| tSHRTIM | | | 4 | - | - | ns |
| tRES(SHRTIM) | High Resolution Step Size | fSHRTIM = 250 MHz, TA from -40 to 105°C | - | 125 | - | ps |
| ResSHRTIM | Timer Resolution | | - | - | 16 | bit |
| tDTG | Dead-Time Generator Clock Cycle | | 0.125 | - | 16 | tSHRTIM |
| | | fSHRTIM = 250 MHz | 0.5 | - | 64 | ns |
| ** | tDTR | / | tDTF | max** | Dead-Time Range (Absolute Value) | |
| | | fSHRTIM = 250 MHz | - | - | 34.07 | µs |
| fCHPFRQ | Chopper-Level Clock Frequency | | 1/256 | - | 1/16 | fSHRTIM |
| | | fSHRTIM = 250 MHz | 0.976 | - | 15.625 | MHz |
| t1STPW | Chopper First Pulse Width | | 16 | - | 256 | tSHRTIM |
| | | fSHRTIM = 250 MHz | 0.064 | - | 1.024 | µs |

Note: Data based on characterization results, not production tested.

Table 4-38 SHRTIM Output Response to Fault Protection (1)

| Symbol | Parameter | Condition | Min | Typical | Max (2) | Unit |
|----------|------------------------------|---|-----|---------|---------|------|
| tLAT(DF) | Digital Fault Response Delay | From SHRTIM_FALTINx digital input to SHRTIM_CHxy output pin propagation delay | - | 9 | 12 | ns |
| TW(FALT) | Minimum Fault Pulse Width | | 8 | - | - | - |
| tLAT(AF) | Analog Fault Response Delay | From COMPx_INP input pin to SHRTIM_CHxy output pin propagation delay | - | 22 | 38 | - |

Notes:

1. Please refer to the Fault Protection section of the SHRTIM chapter in the User Manual.
2. Data based on characterization results, not production tested.

Table 4-39 SHRTIM Output Response to External Events 1 to 10 (Low Latency Mode (1))

| Symbol | Parameter | Condition | Min | Typ (2) | Max (2) | Unit |
|------------|---------------------------------------|---|-----|---------|---------|------|
| tLAT(DEEV) | Digital External Event Response Delay | From SHRTIM_EXEVx digital input to SHRTIM_CHxy output pin propagation delay (30pF load) | - | 11 | 17 | ns |
| TW(EEV) | Minimum External Event Pulse Width | | 8 | - | - | - |

| Symbol | Parameter | Condition | Min | Typ (2) | Max (2) | Unit |
|-------------------|--------------------------------------|--|-----|---------|---------|------|
| tLAT(AEEV) | Analog External Event Response Delay | From COMPx_INP input pin to SHRTIM_CHxy output pin propagation delay (30pF load) | - | 24 | 42 | - |

Notes:

1. Please refer to the External Event Delay section of the SHRTIM chapter in the User Manual.
2. Data based on characterization results, not production tested.

Table 4-40 SHRTIM Output Response to External Events 1 to 10 (Synchronized Mode (1))

| Symbol | Parameter | Condition | Min | Typ | Max (2) | Unit |
|-------------------|---------------------------------------|---|-----|-----|---------|---------|
| tLAT(DEEV) | Digital External Event Response Delay | From SHRTIM_EXEVx digital input pin to SHRTIM_CHxy output pin (30pF load) propagation delay (3) | - | 47 | 51 | ns |
| tLAT(AEEV) | Analog External Event Response Delay | From COMPx_INP input pin to SHRTIM_CHxy output pin (30pF load) propagation delay (3) | - | 58 | 71 | ns |
| tW(EEV) | Minimum External Event Pulse Width | | 8 | - | - | ns |
| TJIT(EEV) | External Event Response Jitter | From SHRTIM_EXEVx digital input or COMPx_INP to SHRTIM_CHxy output pin delay jitter | - | - | 1 | tSHRTIM |

Notes:

1. Please refer to the External Event Delay section of the SHRTIM chapter in the User Manual.
2. Data based on characterization results, not production tested.
3. This parameter is given for $f_{SHRTIM} = 250 \text{ MHz}$.
4. $t_{SHRTIM} = 1 / f_{SHRTIM}$, $f_{SHRTIM} = 250 \text{ MHz}$.

Table 4-41 SHRTIM Synchronous Input/Output (1)

| Symbol | Parameter | Condition | Min | Typ | Max | Unit |
|--------------------|--|--------------------------------|-----|-----|-----|---------|
| tW(SYNCIN) | Minimum Pulse Width for Sync Input (including SHRTIM_SCIN) | | 1 | - | - | tSHRTIM |
| tRES(ESR) | Response Time to External Sync Request | | - | - | 3 | tSHRTIM |
| tW(SYNCOUT) | Pulse Width for SHRTIM_SCOUT Output | | - | 16 | - | tSHRTIM |
| | | $f_{SHRTIM} = 250 \text{ MHz}$ | - | 64 | - | ns |

Note: Guaranteed by design, not production tested.

4.3.17 SDRAM Characteristics

Figure 4-14 SDRAM R/W Timing

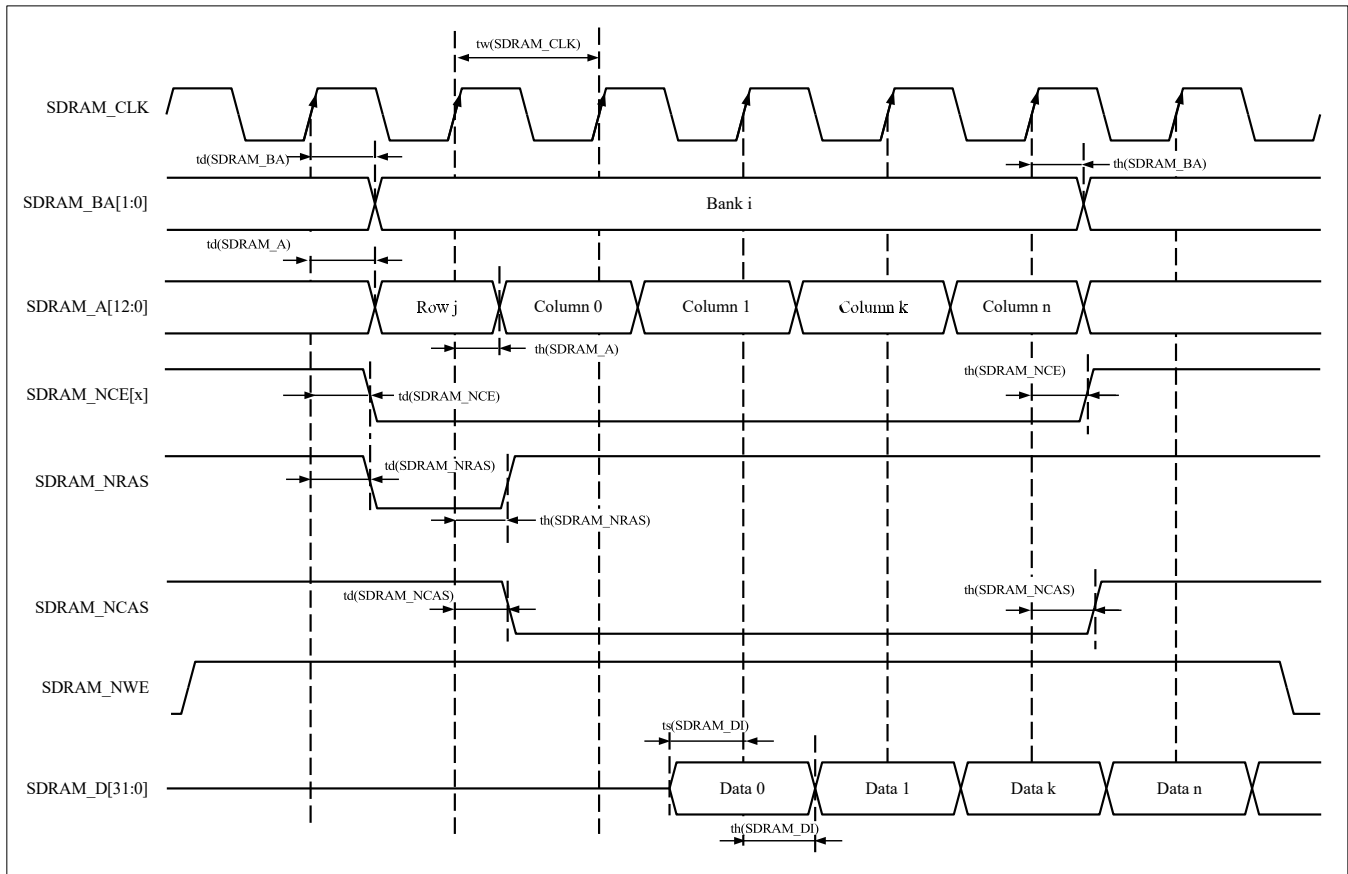
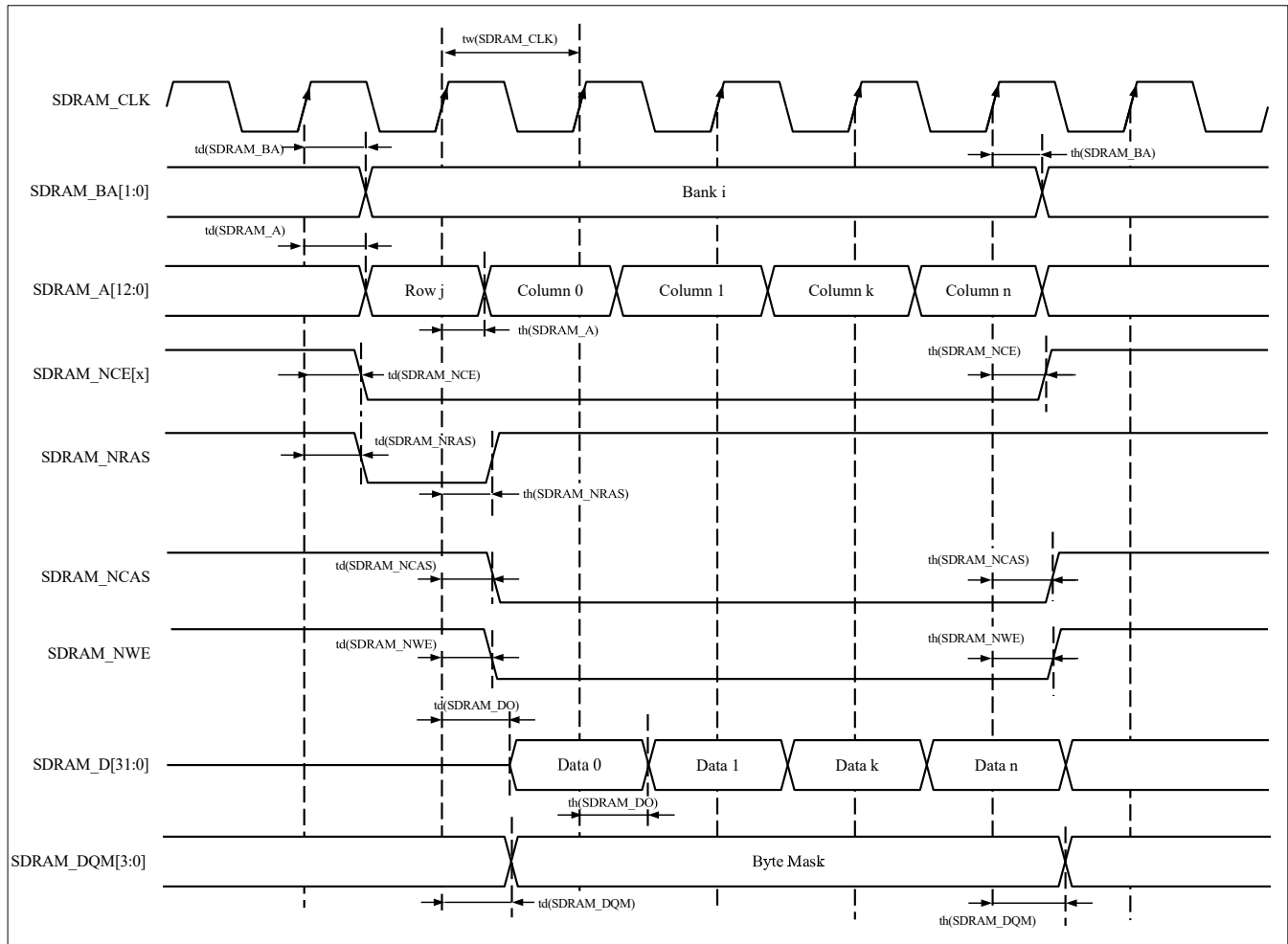

Table 4-42: SDRAM Read Timing ⁽¹⁾

| Symbol | Parameter | Min | Max | Unit |
|---------------------------|---------------------------------|------------|-----|------|
| $t_w(\text{SDRAM_CLK})$ | SDRAM_CLK Period | 7.51(133M) | - | ns |
| $t_d(\text{SDRAM_BA})$ | Bank Address Valid Time | - | 4.0 | |
| $t_h(\text{SDRAM_BA})$ | Bank Address Hold Time | 2.0 | - | |
| $t_d(\text{SDRAM_A})$ | Address (Row/Column) Valid Time | - | 4.0 | |
| $t_h(\text{SDRAM_A})$ | Address (Row/Column) Hold Time | 2.0 | - | |
| $t_d(\text{SDRAM_NCE})$ | Chip Select Valid Time | - | 4.0 | |
| $t_h(\text{SDRAM_NCE})$ | Chip Select Hold Time | 2.0 | - | |
| $t_d(\text{SDRAM_NRAS})$ | SDRAM_NRAS Valid Time | - | 4.0 | |
| $t_h(\text{SDRAM_NRAS})$ | SDRAM_NRAS Hold Time | 2.0 | - | |
| $t_d(\text{SDRAM_NCAS})$ | SDRAM_NCAS Valid Time | - | 4.0 | |
| $t_h(\text{SDRAM_NCAS})$ | SDRAM_NCAS Hold Time | 2.0 | - | |
| $t_s(\text{SDRAM_DI})$ | Data Input Setup Time | 1.2 | - | |

| | | | | |
|-------------------------|----------------------|-----|---|--|
| $t_h(\text{SDRAM_DI})$ | Data Input Hold Time | 1.5 | - | |
|-------------------------|----------------------|-----|---|--|

Figure 4-15 SDRAM Write Timing

Table 4-43: SDRAM Write Timing ⁽¹⁾

| Symbol | Parameter | Min | Max | Unit |
|--------------------------|---------------------------------|------------|-----|------|
| $t_w(\text{SDRAM_CLK})$ | SDRAM_CLK Period | 7.51(133M) | - | ns |
| $t_d(\text{SDRAM_BA})$ | Bank Address Setup Time | - | 4.0 | |
| $t_h(\text{SDRAM_BA})$ | Bank Address Hold Time | 2.0 | - | |
| $t_d(\text{SDRAM_A})$ | Address (Row/Column) Setup Time | - | 4.0 | |
| $t_h(\text{SDRAM_A})$ | Address (Row/Column) Hold Time | 2.0 | - | |
| $t_d(\text{SDRAM_NCE})$ | Chip Select Setup Time | - | 4.0 | |
| $t_h(\text{SDRAM_NCE})$ | Chip Select Hold Time | 2.0 | - | |

| | Chip Select Hold Time | | |
|---------------------------|----------------------------|------------|-----|
| $t_d(\text{SDRAM_NRAS})$ | SDRAM_NRAS Hold Time | - | 4.0 |
| $t_h(\text{SDRAM_NRAS})$ | SDRAM_NRAS Hold Time | 2.0 | - |
| $t_d(\text{SDRAM_NCAS})$ | SDRAM_NCAS Hold Time | - | 4.0 |
| $t_h(\text{SDRAM_NCAS})$ | SDRAM_NCAS Hold Time | 2.0 | - |
| $t_d(\text{SDRAM_NWE})$ | Write Enable Hold Time | - | 4.0 |
| $t_h(\text{SDRAM_NWE})$ | Write Enable Hold Time | 2.0 | - |
| $t_d(\text{SDRAM_DO})$ | Data Output Hold Time | 7.51(133M) | - |
| $t_h(\text{SDRAM_DO})$ | Data Output Hold Time | - | 4.0 |
| $t_d(\text{SDRAM_DQM})$ | Output Byte Mask Hold Time | 2.0 | - |
| $t_h(\text{SDRAM_DQM})$ | Output Byte Mask Hold Time | - | 4.0 |

4.3.18 Watchdog Features

Table 4-44: IWDG Maximum and Minimum Count Reset Times (LSI = 32 KHz)

| Prescaler | PD[2:0] | Minimum Duration RL[11:0]=0 | Maximum Duration RL[11:0]=0xFFF | Unit |
|-----------|---------|-----------------------------|---------------------------------|------|
| /4 | 000 | 0.125 | 512 | ms |
| /8 | 001 | 0.25 | 1024 | |
| /16 | 010 | 0.5 | 2048 | |
| /32 | 011 | 1.0 | 4096 | |
| /64 | 100 | 2.0 | 8192 | |
| /128 | 101 | 4.0 | 16384 | |
| /256 | 11x | 8.0 | 32768 | |

1. Guaranteed by design, not tested in production.

Table 4-45: WWDG Maximum and Minimum Count Reset Times (PCLK1 = 150MHz)

| Prescaler | TIMERB[1:0] | Minimum Timeout | Maximum Timeout | Unit |
|-----------|-------------|-----------------|-----------------|------|
| /1 | 0 | 0.02728 | 445.54 | ms |
| /2 | 1 | 0.05456 | 891.07 | |
| /4 | 2 | 0.1088 | 1782.14 | |
| /8 | 3 | 0.2184 | 3564.29 | |

1. Guaranteed by design, not tested in production.

4.3.19 I2C Interface Features

Unless specified otherwise, the parameters listed in **Table 4-44** are measured with environmental temperature, fPCLK1 frequency, and VDD supply voltage meeting the conditions in **Table 4-4**.

This product's I2C interface complies with the standard I2C communication protocol, but with the following limitations: SDA and SCL are not "true" open-drain pins. When configured for open-drain output, the PMOS transistor between the pin and VDD is turned off, but still exists.

For detailed characteristics of I2C pins (SDA and SCL) and input/output multiplexing features, refer to section 4.3.12.

Table 4-46: I2C Interface Features (1)

| Symbol | Parameter | Standard Mode | | Fast Mode | | Fast+Mode | | High-speed mode | | Unit |
|------------------------------|---|---------------|--|-----------|--|-----------|--|-----------------|--|---------|
| | | Min | Max | Min | Max | Min | Max | Min | Max | |
| f_{SCL} | I2C Interface Frequency | 0.0 | 100 | 0 | 400 | 0 | 1000 | 0 | 3400 | KHz |
| $t_{h(STA)}$ | Start Condition Hold Time | 4.0 | - | 0.6 | - | 0.26 | - | 0.16 | - | μ s |
| $t_{w(SCLL)}$ | SCL Clock Low Time | 4.7 | - | 1.3 | - | 0.5 | - | 0.16 | - | μ s |
| $t_{w(SCLH)}$ | SCL Clock High Time | 4.0 | - | 0.6 | - | 0.26 | - | 0.06 | - | μ s |
| $t_{su(STA)}$ | Repeated Start Condition Setup Time | 4.7 | - | 0.6 | - | 0.26 | - | 0.16 | - | μ s |
| $t_{h(SDA)}$ | SDA Data Hold Time | 0 | - | 0 | - | 0 | - | 0 | - | μ s |
| $t_{su(SDA)}$ | SDA Setup Time | 250.0 | - | 100 | - | 50 | - | 10 | - | ns |
| $t_{r(SDA)}$ $t_{r(SCL)}$ | SC, SDA Rise Time | - | 1000 | 20 | 300 | - | 120 | 10 | SCL=40 SDA=80 | ns |
| $t_{f(SDA)}$ $t_{f(SCL)}$ | SCL, SDA Fall Time | - | 300 | - | 300 | - | 120 | 10 | SCL=40 SDA=80 | ns |
| $t_{su(STO)}$ | Stop Condition Setup Time | 4.0 | - | 0.6 | - | 0.26 | - | 0.16 | - | μ s |
| $t_{w(STO:STA)}$ | Stop Condition to Start Condition Time (Bus Idle) | 4.7 | - | 1.3 | - | 0.5 | - | - | - | μ s |
| C_b | Capacitive Load per Bus | - | 400 | - | 400 | - | 400 | - | 400 | pf |
| $t_v(SDA)$ | Data Valid Time | - | 3.45 | - | 0.9 | - | 0.45 | - | 0.1 | μ s |
| $t_v(ACK)$ | Acknowledge Valid Time | - | 3.45 | - | 0.9 | - | 0.45 | - | 0.1 | μ s |
| t_{SP} | Input Filter Spike Pulse Width Suppression | 0 | Analog filter: 35ns. Digital filter: up to 15 I2CCLK period | 0 | Analog filter: 35ns. Digital filter: up to 15 I2CCLK period | 0 | Analog filter: 35ns. Digital filter: up to 15 I2CCLK period | 0 | Analog filter: 35ns. Digital filter: up to 15 I2CCLK period | ns |

1. Guaranteed by design, not tested in production.

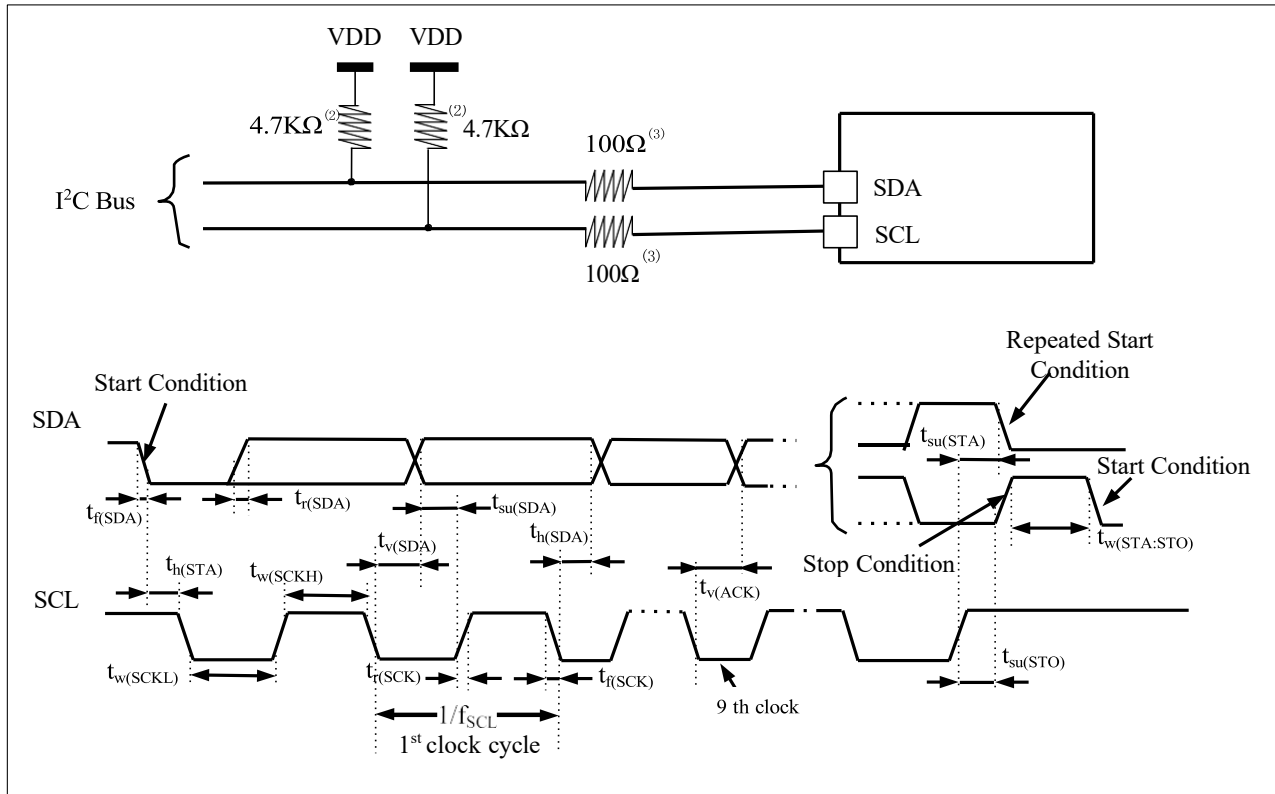
Figure 4-16: I2C Bus AC Waveform and Measurement Circuit⁽¹⁾

1. Measurement points are set at CMOS levels: $0.3V_{DD}$ and $0.7V_{DD}$.
2. Pull-up resistor values depend on the I2C interface speed.
3. Resistance values depend on actual electrical characteristics; serial resistors can be omitted and signal lines can be directly connected.

4.3.20 SPI/I2S Interface Characteristics

Unless otherwise specified, the SPI parameters listed in Table 4-47 and the I2S parameters listed in Table 4-48 are measured at ambient temperature (25°C), f_{PCLKx} frequency, and V_{DD} supply voltage meeting the conditions in Table 4-4.

For details on the characteristics of input/output multiplexed function pins (NSS, SCLK, MOSI, MISO for SPI; WS, CLK, SD for I2S), refer to Section 4.3.13 (IO Port Characteristics).

Table 4-47 SPI Characteristics⁽¹⁾

| Symbol | Parameter | Conditions | Min | Typ | Max | Unit |
|-----------|---------------------|--|-----|-----|-----|------|
| f_{sck} | SPI clock frequency | Master mode $2.3 < V_{DD} < 3.6\text{ V}$ SPI1, 2, 3 | - | - | 80 | MHz |

| | | | | | | |
|--|--------------------------|--|--------------|------------|--------------|----|
| | | Master mode 2.7<VDD<3.6 V SPI1, 2, 3 | - | - | 100 | |
| | | Master mode 2.3<VDD<3.6 V SPI4, 5, 6 | - | - | 50 | |
| | | Slave receive 2.3<VDD<3.6 V | - | - | 100 | |
| | | Slave transmit mode/full 2.7<VDD<3.6 V | - | - | 31 | |
| | | Slave transmit mode/full 2.3 <VDD<3.6 V | - | - | 29 | |
| $t_{su(NSS)}^{(1)}$ | NSS setup time | Slave mode | 2 | - | - | |
| $t_{h(NSS)}^{(1)}$ | NSS hold time | Slave mode | 1 | - | - | - |
| $t_w(SCKH)^{(1)}$ $t_w(SCKL)^{(1)}$ | SCK high and low time | Master mode | $T_{pclk}-2$ | T_{pclk} | $T_{pclk}+2$ | |
| $t_{su(MI)}^{(1)}$ | Data input setup time | Master mode | 1 | - | - | ns |
| $t_{su(SI)}^{(1)}$ | | Slave mode | 1 | - | - | |
| $t_{h(MI)}^{(1)}$ | Data input hold time | Master mode | 4 | - | - | |
| $t_{h(SI)}^{(1)}$ | | Slave mode | 2 | - | - | |
| $t_{a(SO)}^{(1)(2)}$ | Data output access time | Slave mode | 9 | 13 | 27 | |
| $t_{dis(SO)}^{(1)(3)}$ | Data output disable time | Slave mode | 0 | 1 | 5 | |
| $t_{v(SO)}^{(1)}$ | Data output valid time | Slave mode 2.7<VDD<3.6 V | - | 12.5 | 16 | |
| $t_{v(MO)}^{(1)}$ | | Slave mode 2.3<VDD<3.6 V | - | 12.5 | 17 | |
| | | Master mode | - | 1 | 3 | |
| $t_{h(SO)}^{(1)}$ | Data output hold time | Slave mode 2.3<VDD<3.6 V | 10 | - | - | |
| $t_{h(MO)}^{(1)}$ | | Master mode | 0 | - | - | |

Notes:

1. Guaranteed by design, not tested in production.
2. Minimum value indicates the minimum time to drive the output, maximum value indicates the maximum time to correctly acquire the data.
3. Minimum value indicates the minimum time to turn off the output, maximum value indicates the maximum time to place the data line in high impedance state.

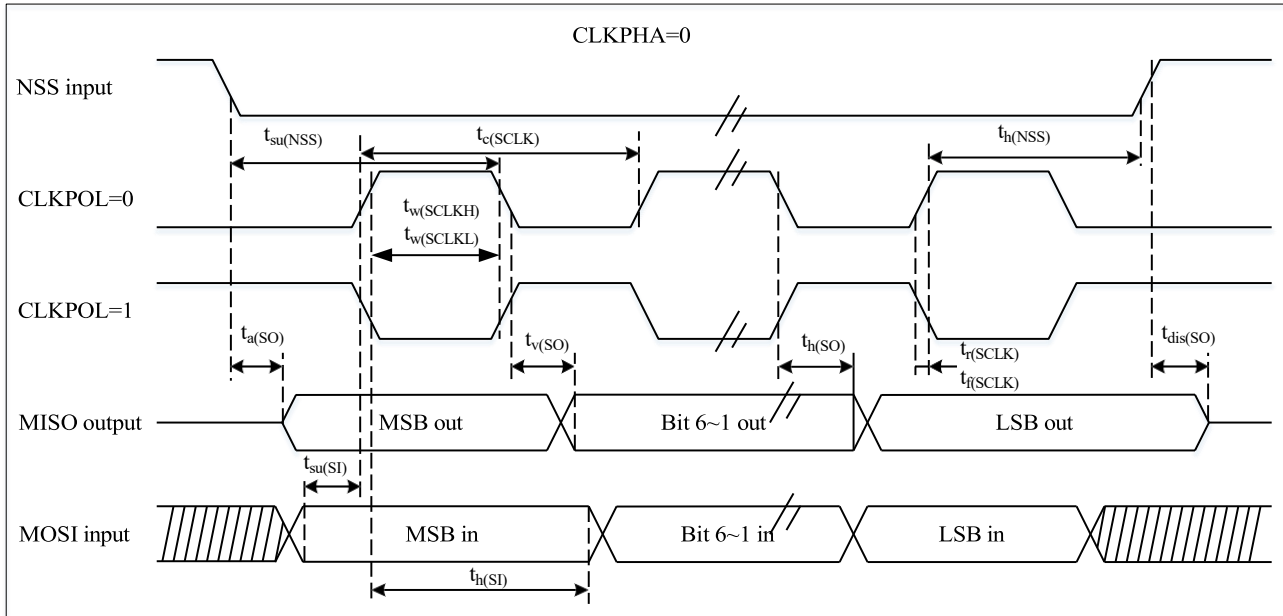
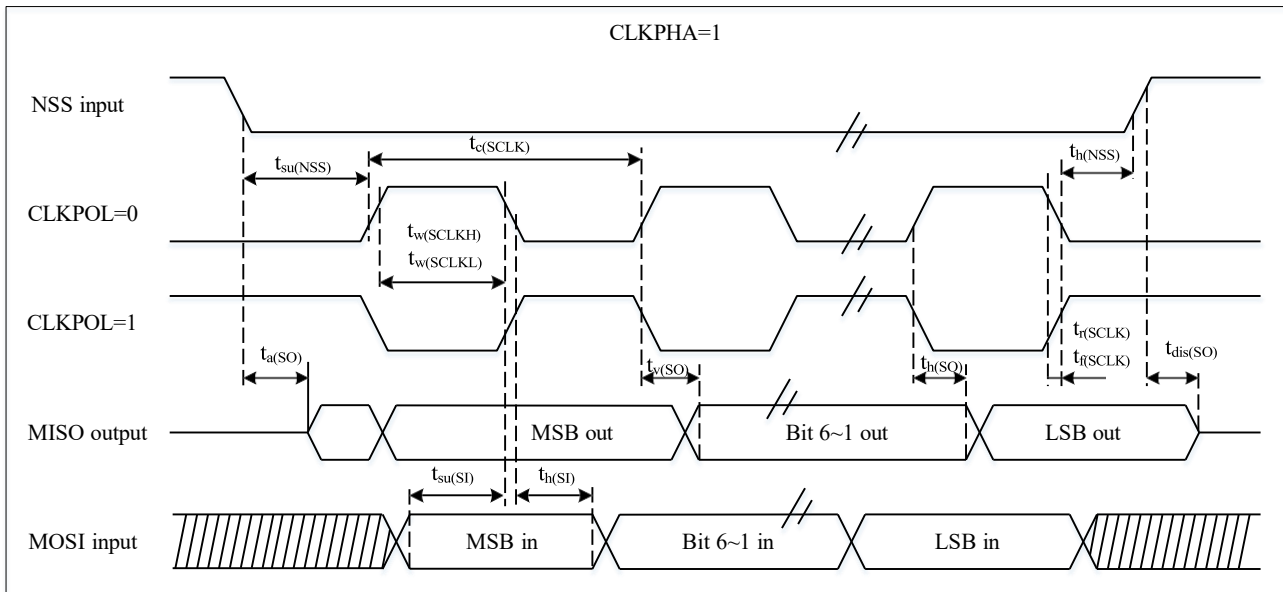
Figure 4-17 SPI Timing Diagram - Slave Mode and CLKPHA=0

Figure 4-18 SPI Timing Diagram — Slave Mode and CLKPHA=1 ⁽¹⁾

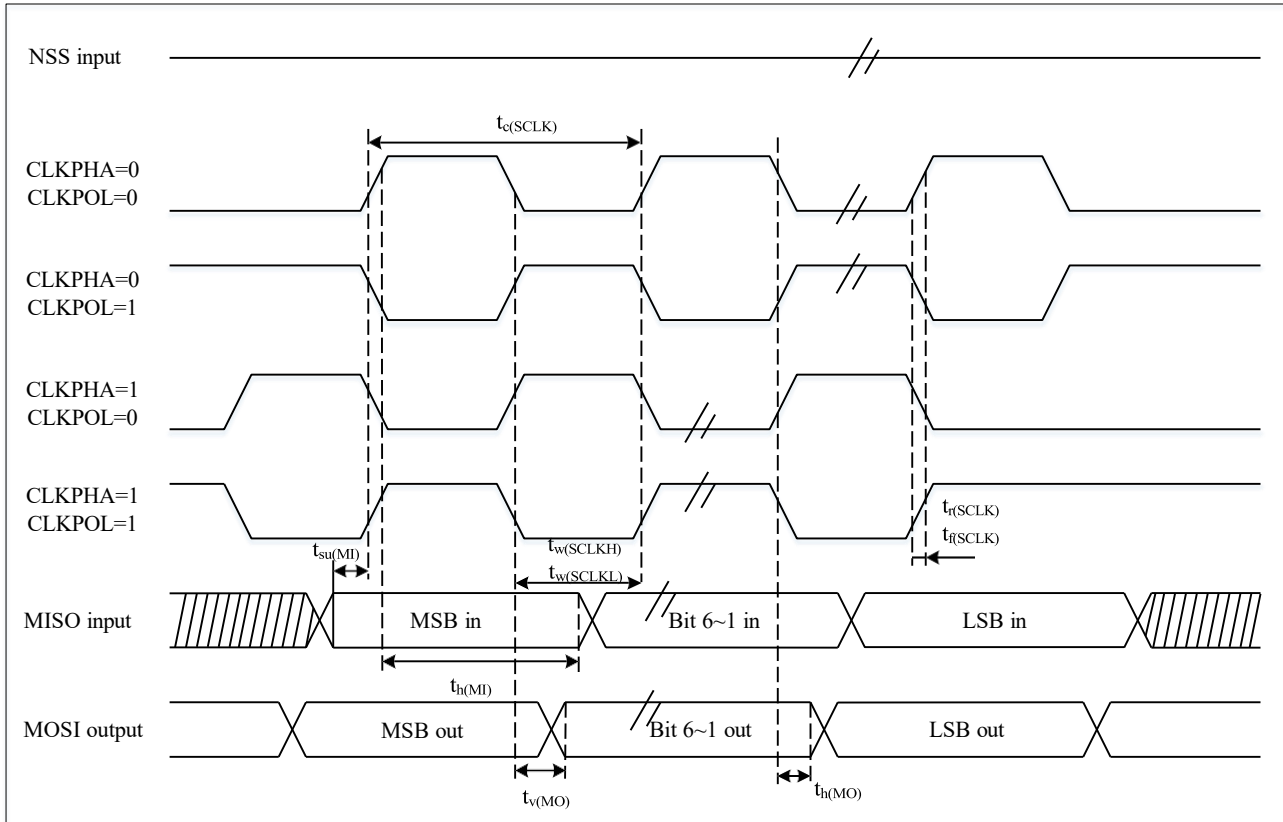
1. Guaranteed by design, not tested in production.

Figure 4-19 SPI Timing Diagram — Master Mode⁽¹⁾

Note: Measurement points are set at 0.5VDD, with external load capacitance (CL) of 30pF.

Table 4-48 I2S Characteristics ⁽¹⁾

| Symbol | Parameter | Conditions | Min | Max | Unit |
|--------------------------|---|--|-------------------|----------------------|------|
| f_{MCLK} | I ² S master clock frequency | Master mode | 256x8K | 256Fs ⁽³⁾ | MHz |
| f_{CLK} | I ² S clock frequency | Master mode (32bit) | - | 64Fs ⁽³⁾ | |
| $1/t_{c(CLK)}$ | | Slave mode (32bit) | - | 64Fs ⁽³⁾ | |
| DuCy(SCK) | I2S slave input clock duty cycle | I2S slave mode | 30 | 70 | % |
| $t_{v(WS)}^{(1)}$ | WS valid time | Master mode | I2S2 | - | 6 |
| | | | I2S3 | - | 6 |
| $t_{h(WS)}^{(1)}$ | WS hold time | Master mode | I2S2 | 2 | - |
| | | | I2S3 | 2 | - |
| $t_{su(WS)}^{(1)}$ | WS setup time | Slave mode | I2S2 | 7 | - |
| | | | I2S3 | 7 | - |
| $t_{h(WS)}^{(1)}$ | WS hold time | Slave mode | I2S2 | 0 | - |
| | | | I2S3 | 0 | - |
| $t_{w(CLKH)}^{(1)}$ | CLK high and low time | - | | 312.5 | - |
| $t_{w(CLKL)}^{(1)}$ | | | | 345 | - |
| $t_{su(SD_MR)}^{(1)}$ | Data input setup time | Master receiver | I2S2 | 6 | - |
| | | | I2S3 | 6 | - |
| Slave receiver | | I2S2 | 7 | - | |
| | | I2S3 | 7 | - | |
| $t_{h(SD_MR)}^{(1)(2)}$ | Data output hold time | Master receiver | I2S2 | 0 | - |
| | | | I2S3 | 0 | - |
| Slave receiver | | I2S2 | 1 | - | |
| | | I2S3 | 1 | - | |
| $t_{v(SD_ST)}^{(1)(2)}$ | Data output valid time | Slave transmitter (after enable edge) | I ² S2 | - | 15 |
| | | | I ² S3 | - | 15 |
| $t_{h(SD_ST)}^{(1)}$ | Data output hold time | Slave transmitter (after enable edge) | I ² S2 | 4 | - |
| | | | I ² S3 | 4 | - |
| $t_{v(SD_MT)}^{(1)(2)}$ | Data output valid time | Master transmitter (after enable edge) | I2S2 | - | 6 |
| | | | I2S3 | - | 6 |
| $t_{h(SD_MT)}^{(1)}$ | Data output hold time | Master transmitter (after enable edge) | I2S2 | 0 | - |
| | | | I2S3 | 0 | - |

Notes:

1. Guaranteed by design, not tested in production.
2. Dependent on f_{PCLK} .
3. Audio sampling frequency.

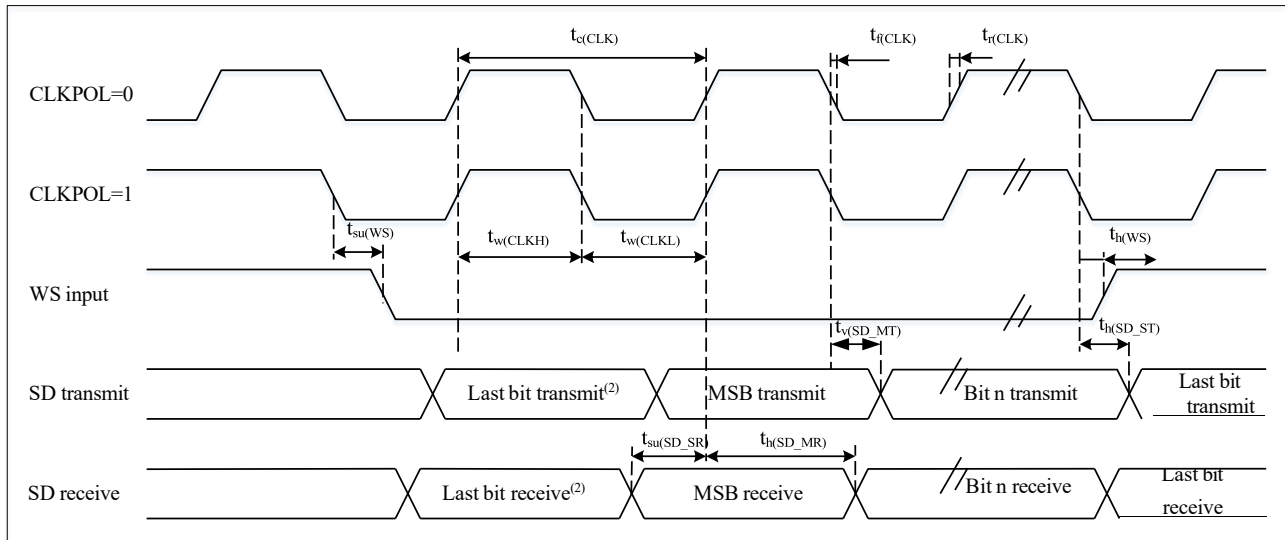
Figure 4-20 I2S Slave Mode Timing Diagram (Philips Protocol) ⁽¹⁾

Notes:

1. Measurement points are set at 0.3V_{DD} and 0.7V_{DD}.
2. The least significant bit of the previous byte is transmitted/received. There is no transmission/reception of this least significant bit before the first byte.

4.3.21 xSPI Interface Characteristics

Table 4-49 xSPI Characteristics in SDR Mode⁽¹⁾⁽²⁾

| Symbol | Parameter | Conditions | Min | Typ | Max | Unit |
|----------------------|---|---|-------------------------------------|-----|-----------------------------------|------|
| F _(CLK) | QSPI clock frequency | 2.3V < V _{DD} < 3.6 V, V _{OS0} , C _{LOAD} = 15 pF | - | - | 92 | MHz |
| | | 2.3 V < V _{DD} < 3.6 V, V _{OS0} , C _{LOAD} = 20 pF | - | - | 90 | |
| | | 2.7 V < V _{DD} < 3.6 V, V _{OS0} , C _{LOAD} = 20 pF | - | 133 | 140 | |
| t _w (CKH) | QSPI clock high/low time, even division | PRESCALER[7:0] = n = 0,1,3,5 | t _(CK) /2 | - | t _(CK) /2+1 | ns |
| t _w (CKL) | | | t _(CK) /2-1 | - | t _(CK) /2 | |
| t _w (CKH) | QSPI clock high/low time, odd division | PRESCALER[7:0] = n = 2,4,6,8 | (n/2)*t _(CK) / (n+1) | - | (n/2)*t _(CK) / (n+1)+1 | |
| t _w (CKL) | | | (n/2+1)*t _(CK) / (n+1)-1 | - | (n/2+1)*t _(CK) / (n+1) | |
| t _s (IN) | Input data setup time | - | 3 | - | - | |
| t _h (IN) | Input data hold time | - | 1.5 | - | - | |
| t _v (OUT) | Output data valid time | - | - | 0.5 | 1 | |
| t _h (OUT) | Output data hold time | - | 0 | - | - | |

Notes:

1. All values apply to both eight-line and four-line SPI modes.
2. Guaranteed by design, not tested in production.

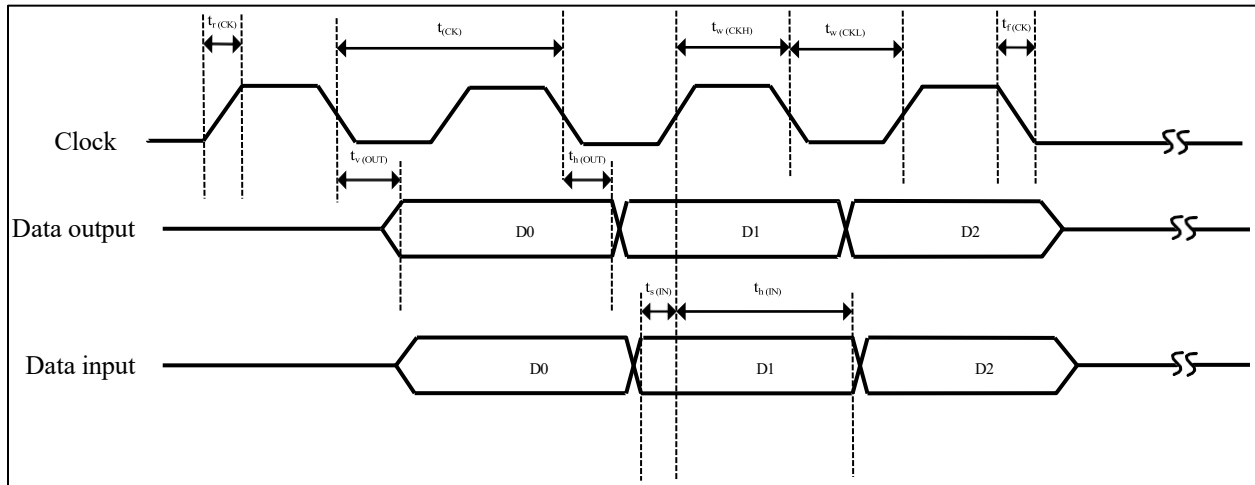
Figure 4-22 xSPI Read/Write Timing in SDR Mode

Table 4-50 xSPI Characteristics in DTR Mode (non-DQS)⁽¹⁾⁽²⁾

| Symbol | Parameter | Conditions | Min | Typ | Max | Unit |
|--|---|--|-----------------------------------|-------------------------|---------------------------------|------|
| F _{CK} | xSPI clock frequency | 2.3V < VDD < 3.6 V, VOS0, CLOAD = 15 pF | - | - | 90 | MHz |
| | | 2.3V < VDD < 3.6 V, VOS0, CLOAD = 20 pF | - | - | 87 | |
| | | 2.7 V < VDD < 3.6 V, VOS0, CLOAD = 20 pF | - | - | 110 | |
| t _w (CKH) | QSPI clock high/low time, even division | TBD | t _{CK} /2 | - | t _{CK} /2+1 | ns |
| t _w (CKL) | | | t _{CK} /2-1 | - | t _{CK} /2 | |
| t _w (CKH) | QSPI clock high/low time, odd division | TBD | (n/2)*t _{CK} / (n+1) | - | (n/2)*t _{CK} / (n+1)+1 | |
| t _w (CKL) | | | (n/2+1)*t _{CK} / (n+1)-1 | - | (n/2+1)*t _{CK} / (n+1) | |
| t _{sr} (IN) t _{sf} (IN) | Input data setup time | - | 3.0 | - | - | |
| t _{hr} (IN) t _{hf} (IN) | Input data hold time | - | 1.50 | - | - | |
| t _{vr} (OUT) t _{vf} (OUT) | Output data valid time | TBD | - | 6 | 7 | |
| | | TBD | - | t _{pelk} /4+ 1 | t _{pelk} /4+1.25 | |
| t _{hr} (OUT) t _{hf} (OUT) | Output data valid time | TBD | 4.5 | - | - | |
| | | TBD | t _{pelk} /4 | - | - | |

Notes:

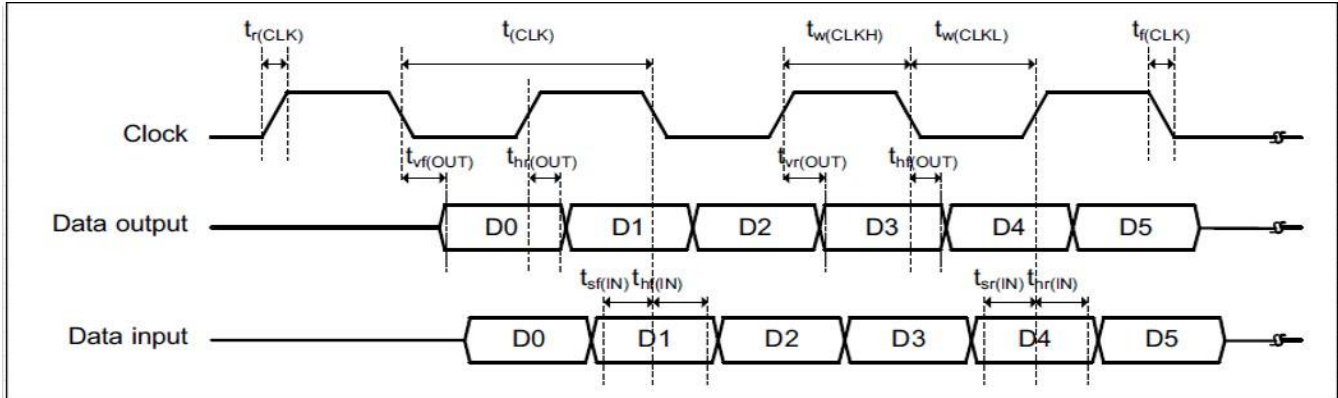
- All values apply to both eight-line and four-line SPI modes.
- Guaranteed by design, not tested in production.

Figure 4-23 xSPI Timing in DTR Mode

Table 4-51 xSPI Characteristics in DTR Mode (with DQS)/Eight-line and Hyperbus Protocol⁽¹⁾

| Symbol | Parameter | Conditions | Min | Typ | Max | Unit |
|-----------------------------|---|--|---------------------------------|-----|-------------------------------|------|
| $F_{\text{CK}}^{(2)(3)}$ | xSPI clock frequency | $2.7\text{ V} < V_{\text{DD}} < 3.6\text{ V}$, V_{OS0} , $C_{\text{LOAD}} = 20\text{ pF}$ | - | - | 100 | MHz |
| | | $2.3\text{ V} < V_{\text{DD}} < 3.6\text{ V}$, V_{OS0} , $C_{\text{LOAD}} = 20\text{ pF}$ | - | - | 100 | |
| $t_{w(\text{CKH})}$ | QSPI clock high/low time, even division | TBD | $t_{\text{CK}}/2$ | - | $t_{\text{CK}}/2+1$ | ns |
| $t_{w(\text{CKL})}$ | | | $t_{\text{CK}}/2-1$ | - | $t_{\text{CK}}/2$ | |
| $t_{w(\text{CKH})}$ | QSPI clock high/low time, odd division | TBD | $(n/2)*t_{\text{CK}}/(n+1)$ | - | $(n/2)*t_{\text{CK}}/(n+1)+1$ | ns |
| $t_{w(\text{CKL})}$ | | | $(n/2+1)*t_{\text{CK}}/(n+1)-1$ | - | $(n/2+1)*t_{\text{CK}}/(n+1)$ | |
| $t_{v(\text{CK})}$ | Clock valid time | - | - | - | $t_{\text{CK}}+1$ | mV |
| $t_{h(\text{CK})}$ | Clock hold time | - | $t_{\text{CK}}/2$ | - | - | |
| $V_{\text{ODr}(\text{CK})}$ | CK rising edge, CK and $\bar{c}\bar{k}$ crossing level | $V_{\text{DD}} = 2.3\text{ V}$ | 922 | - | 1229 | |
| $V_{\text{ODf}(\text{CK})}$ | CK falling edge, CK and $\bar{c}\bar{k}$ crossing level | $V_{\text{DD}} = 2.3\text{ V}$ | 1000 | - | 1277 | |
| $t_{w(\text{CS})}$ | Chip select high level time | - | $3 * t_{\text{CK}}$ | - | - | ns |
| $t_{v(\text{DQ})}$ | Input data valid data | - | 0 | - | - | |
| $t_{v(\text{DS})}$ | Input data strobe valid data | - | 0 | - | - | |
| $t_{h(\text{DS})}$ | Input data strobe hold time | - | 0 | - | - | |
| $t_{v(\text{RWDQ})}$ | Output data strobe valid data | - | - | - | $3 * t_{\text{CK}}$ | |
| $t_{sr(\text{DQ})}$ | Input data setup time | Rising edge | 0 | - | - | |
| $t_{sf(\text{DQ})}$ | | Falling edge | 0 | - | - | |
| $t_{hr(\text{DQ})}$ | Input data hold time | Rising edge | 1 | - | - | |
| $t_{hf(\text{DQ})}$ | | Falling edge | 1 | - | - | |

| | | | | | |
|---------------|------------------------------------|-----|--------------|------------------|-------------------|
| $t_{vr(OUT)}$ | Output data Rising edgevalid data | TBD | - | 6 | 7 |
| | | TBD | - | $t_{pelk}/4+1$ | $t_{pelk}/4+1.25$ |
| $t_{vf(OUT)}$ | Output data Falling edgevalid data | TBD | - | 5.5 | 6 |
| | | TBD | - | $t_{pelk}/4+0.5$ | $t_{pelk}/4+0.75$ |
| $t_{hr(OUT)}$ | Output data Rising edgehold time | TBD | 4.5 | - | - |
| | | TBD | $t_{pelk}/4$ | - | - |
| $t_{hf(OUT)}$ | Output data Falling edgehold time | TBD | 4.5 | - | - |
| | | TBD | $t_{pelk}/4$ | - | - |

Notes:

1. Guaranteed by design, not tested in production.
2. The maximum deviation for the maximum frequency values given from RWDS to DQ is +/-1.0ns
3. To achieve this frequency, the corresponding register must be activated.

Figure 4-24 xSPI Hyperbus Clock Timing Diagram4-3 xSPI Hyperbus

Figure 4-25 xSPI Hyperbus Clock Read Timing Diagram4-4 xSPI Hyperbus

Figure 4-26 xSPI Hyperbus Clock Write Timing Diagram

4.3.22 FEMC Characteristics

- Asynchronous Waveforms and Timing

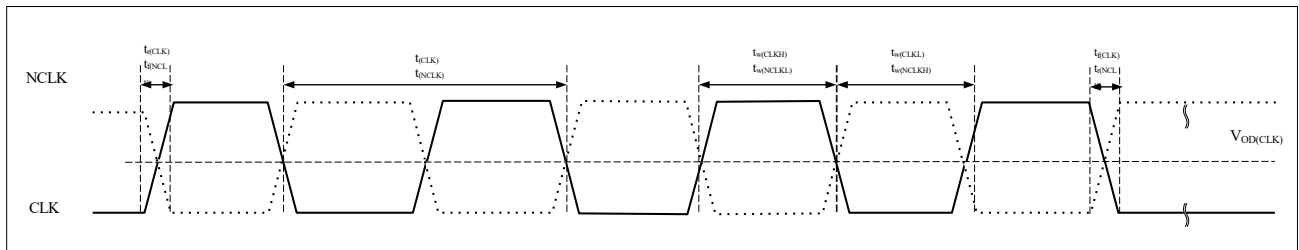
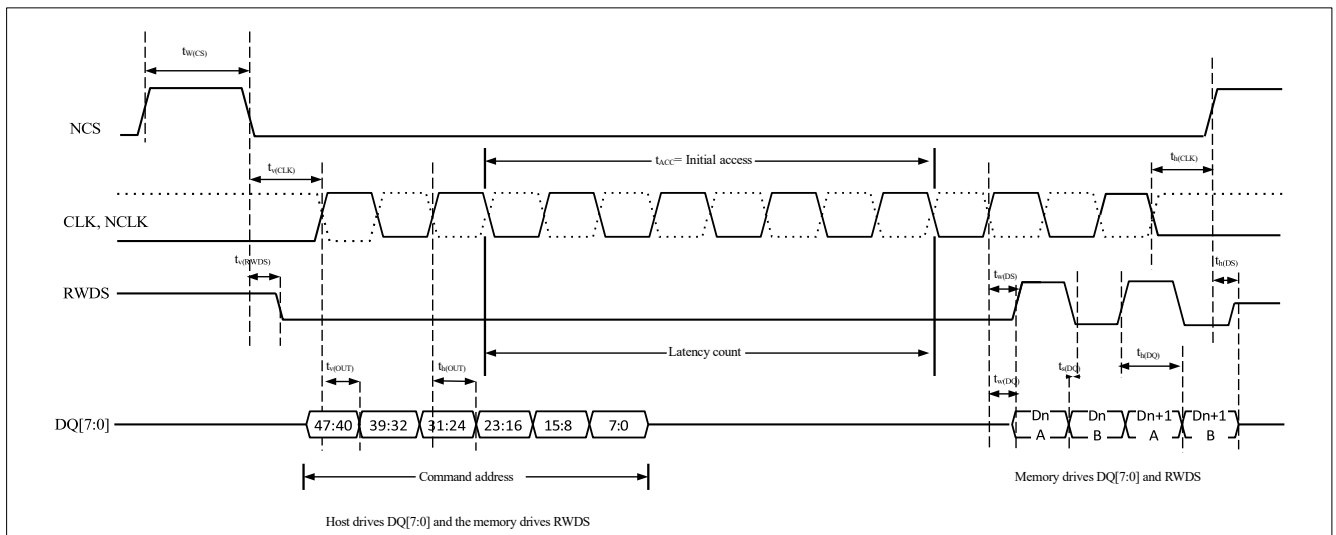
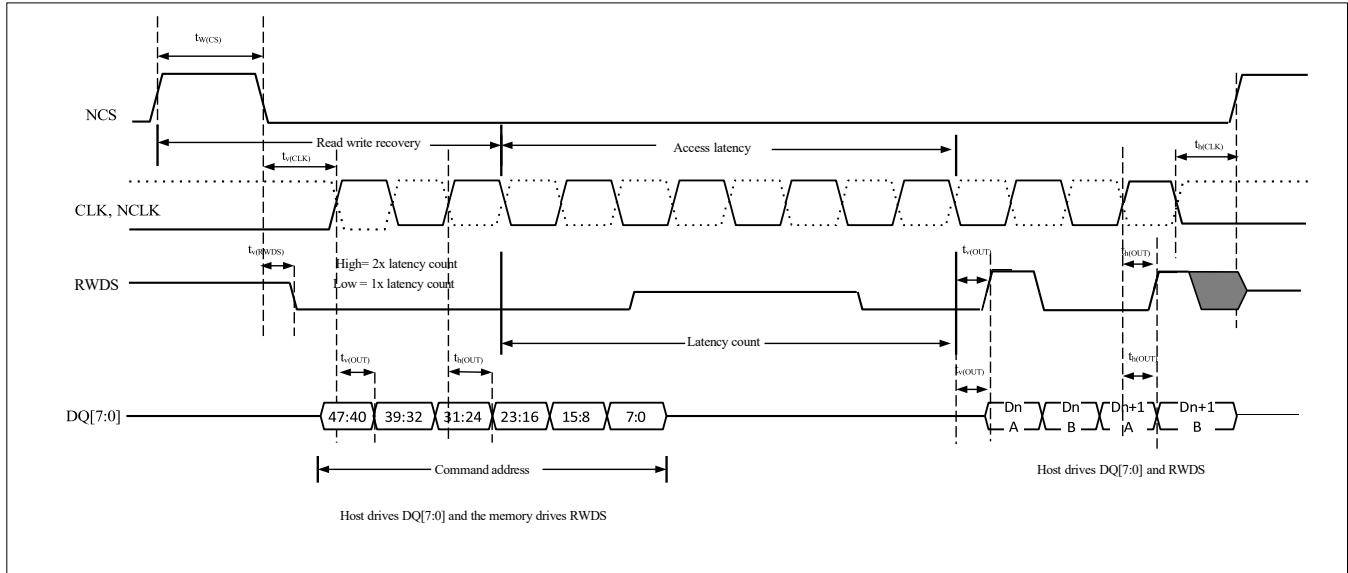
Figures 4-26 to 4-29 show the asynchronous waveforms, and Tables 4-45 to 4-48 provide the corresponding timing parameters.

Figure 4-27 Asynchronous Non-Multiplexed Bus SRAM/PSRAM/NOR Read Operation Waveform

Table 4-52 Asynchronous Non-Multiplexed Bus SRAM/PSRAM/NOR Read Operation Timing (1)(2)

| Symbol | Parameter | Min ⁽³⁾ | Max ⁽³⁾ | Unit |
|---------------------------|---|--------------------|--------------------|------|
| $t_{w(NE)}$ | FEMC_NE low time | TBD | TBD | ns |
| $t_{v(NO\bar{E}_{NE})}$ | FEMC_Nex low to FEMC_NOElow | TBD | TBD | ns |
| $t_{w(NO\bar{E})}$ | FEMC_NOE low time | TBD | TBD | ns |
| $t_{h(NE_NO\bar{E})}$ | FEMC_NOE high to FEMC_NE high hold time | TBD | TBD | ns |
| $t_{v(A_NE)}$ | FEMC_Nex low to FEMC_A valid | TBD | TBD | ns |
| $t_{h(A_NO\bar{E})}$ | Address hold time after FEMC_NOE high | TBD | TBD | ns |
| $t_{v(BL_NE)}$ | FEMC_NEx low to FEMC_NBL valid | TBD | TBD | ns |
| $t_{h(BL_NO\bar{E})}$ | FEMC_NBL hold time after FEMC_NOE high | TBD | TBD | ns |
| $t_{su(Data_NE)}$ | Data setup time to FEMC_NEx high | TBD | TBD | ns |
| $t_{su(Data_NO\bar{E})}$ | Data setup time to FEMC_NOEx high | TBD | TBD | ns |
| $t_{h(Data_NO\bar{E})}$ | Data hold time after FEMC_NOE high | TBD | TBD | ns |
| $t_{h(Data_NE)}$ | Data hold time after FEMC_NEx high | TBD | TBD | ns |

Notes:

- IO drive strength = 8 mA, capacitive load = 30 pF
- Measurement point set at CMOS level: 0.5 VDD
- $t_{HCLK} \geq 1 / 240$ MHz

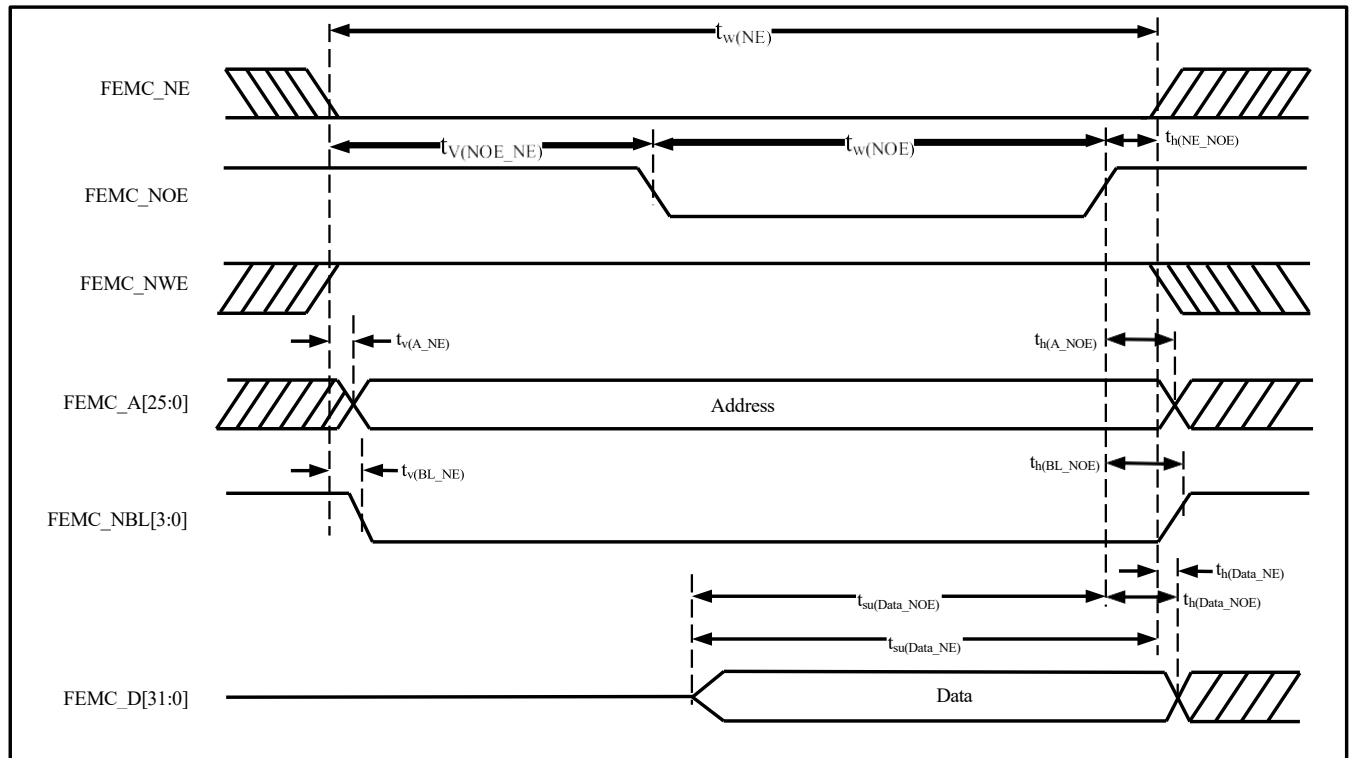
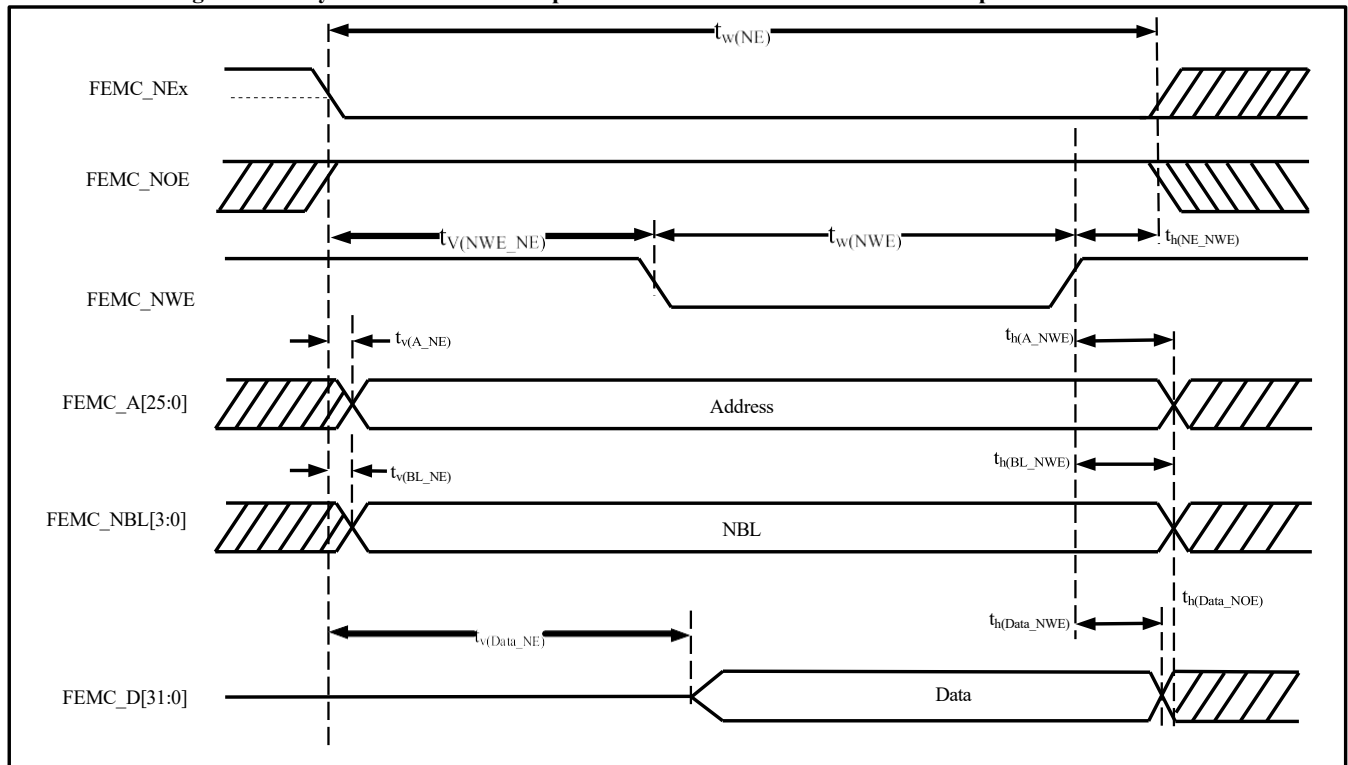
Figure 4-28 Asynchronous Non-Multiplexed Bus SRAM/PSRAM/NOR Write Operation Waveform

Table 4-53 Asynchronous Non-Multiplexed Bus SRAM/PSRAM/NOR Write Operation Timing (1)(2)

| Symbol | Parameter | Min ⁽³⁾ | Max ⁽³⁾ | Unit |
|--------|-----------|--------------------|--------------------|------|
|--------|-----------|--------------------|--------------------|------|

| | | | | |
|--------------------|--|-----|-----|----|
| $t_{w(NE)}$ | FEMC_NE low time | TBD | TBD | ns |
| $t_{v(NWE_NE)}$ | FEMC_NEx low to FEMC_NWE low | TBD | TBD | ns |
| $t_{w(NWE)}$ | FEMC_NWE low time | TBD | TBD | ns |
| $t_{h(NE_NWE)}$ | Hold time from FEMC_NWE high to FEMC_NE high | TBD | TBD | ns |
| $t_{v(A_NE)}$ | FEMC_NEx low to FEMC_A valid | TBD | TBD | ns |
| $t_{h(A_NWE)}$ | Address hold time after FEMC_NWE high | TBD | TBD | ns |
| $t_{v(BL_NE)}$ | FEMC_NEx low to FEMC_NBL valid | TBD | TBD | ns |
| $t_{h(BL_NWE)}$ | FEMC_NBL hold time after FEMC_NWE high | TBD | TBD | ns |
| $t_{v(Data_NE)}$ | FEMC_NEx low to data valid | TBD | TBD | ns |
| $t_{h(Data_NWE)}$ | Data hold time after FEMC_NWE high | TBD | TBD | ns |

Notes:

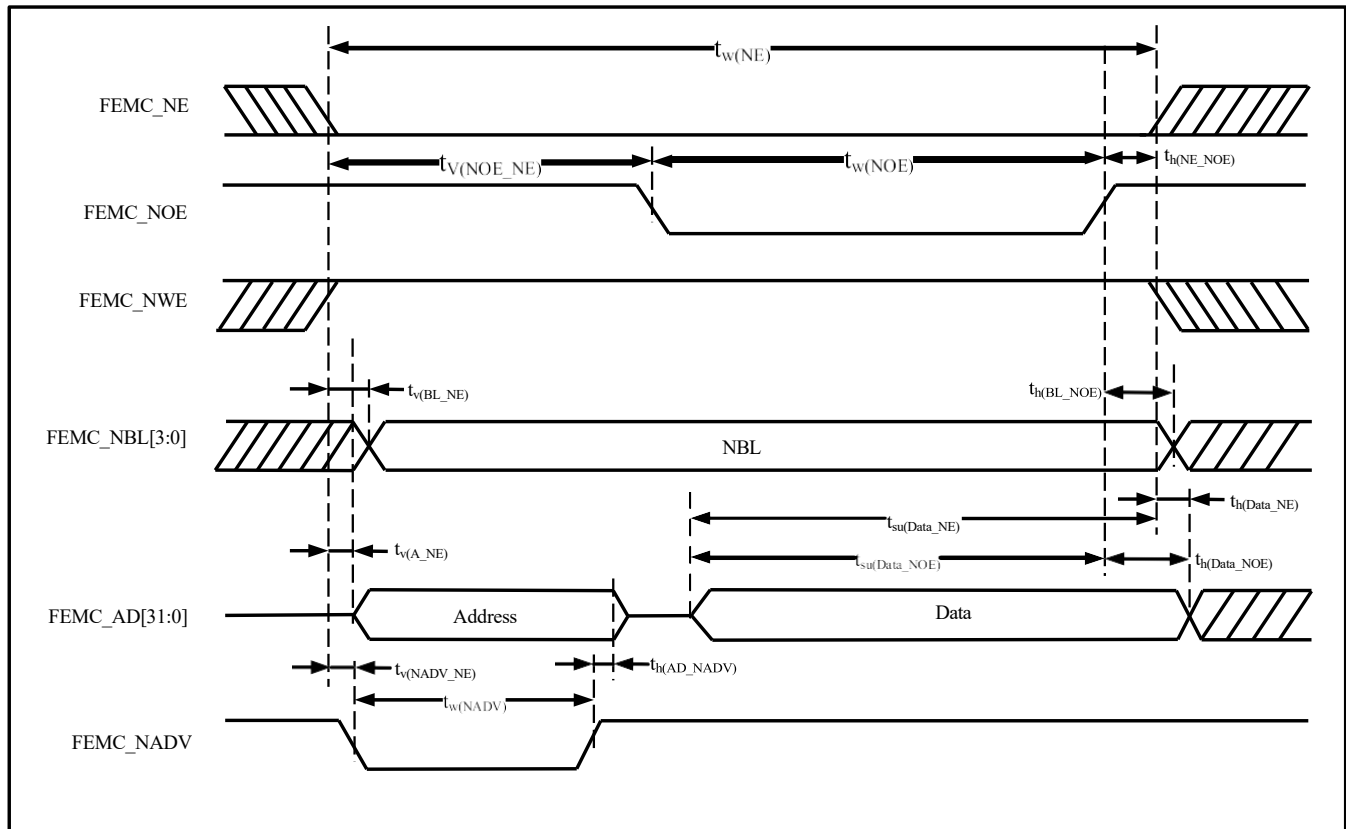
1. IO drive strength = 8 mA, capacitive load = 30 pF
2. Measurement point set at CMOS level: 0.5 VDD
3. $t_{HCLK} \geq 1 / 240$ MHz

Figure 4-29 Asynchronous Bus Multiplexed PSRAM/NOR Read Operation Waveform

Table 4-54 Asynchronous Bus Multiplexed PSRAM/NOR Read Timing ⁽¹⁾⁽²⁾

| Symbol | Parameter | Min ⁽³⁾ | Max ⁽³⁾ | Unit |
|------------------|---|--------------------|--------------------|------|
| $t_{w(NE)}$ | FEMC_NOE High to FEMC_NE High Hold Time | TBD | TBD | ns |
| $t_{v(NOE_NE)}$ | FEMC_NEx Low to FEMC_A Valid | TBD | TBD | ns |

| | | | | |
|---------------------|---|-----|-----|----|
| $t_{w(NOE)}$ | FEMC_NEx Low to FEMC_NADV Low | TBD | TBD | ns |
| $t_{h(NE_NOE)}$ | FEMC_NADV Low Time | TBD | TBD | ns |
| $t_{v(A_NE)}$ | FEMC_NEx低至FEMC_A有效 | TBD | TBD | ns |
| $t_{v(NADV_NE)}$ | FEMC_AD (Address) Valid Hold Time After | TBD | TBD | ns |
| $t_{w(NADV)}$ | FEMC_NADV High | TBD | TBD | ns |
| $t_{h(AD_NADV)}$ | Address Hold Time After FEMC_NOE High | TBD | TBD | ns |
| $t_{h(A_NOE)}$ | FEMC_NBL Hold Time After FEMC_NOE High | TBD | TBD | ns |
| $t_{h(BL_NOE)}$ | FEMC_NEx Low to FEMC_NBL Valid | TBD | TBD | ns |
| $t_{v(BL_NE)}$ | FEMC_NEx低至FEMC_NBL有效 | TBD | TBD | ns |
| $t_{su(Data_NE)}$ | Data Setup Time to FEMC_NEx High | TBD | TBD | ns |
| $t_{su(Data_NOE)}$ | Data Setup Time to FEMC_NOE High | TBD | TBD | ns |
| $t_{h(Data_NE)}$ | Data Hold Time After FEMC_NEx High | TBD | TBD | ns |
| $t_{h(Data_NOE)}$ | Data Hold Time After FEMC_NOE High | TBD | TBD | ns |

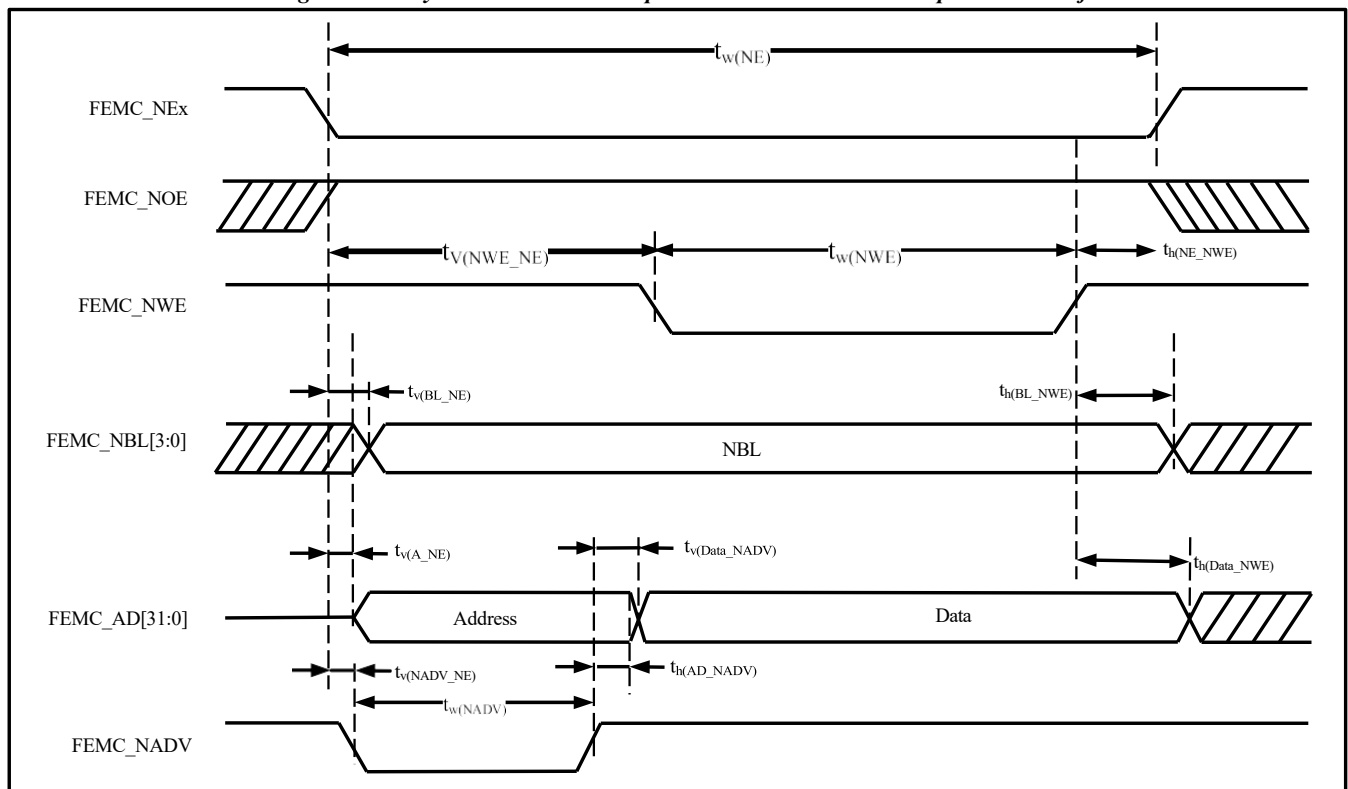
1. IO drive capability 8mA, Capacitive load = 30 pF
2. Measurement points are set at CMOS level: 0.5VDD
3. $t_{HCLK} >= 1/240\text{MHz}$

Figure 4-30 Asynchronous Bus Multiplexed PSRAM/NOR Write Operation Waveform

Table 4-55 Asynchronous Bus-Multiplexed PSRAM/NOR Read Operation Timing ⁽¹⁾⁽²⁾

| Symbol | Parameter | Min ⁽³⁾ | Max ⁽³⁾ | Unit |
|------------------|------------------------------|--------------------|--------------------|------|
| $t_{w(NE)}$ | FEMC_NE low time | TBD | TBD | ns |
| $t_{v(NWE_NE)}$ | FEMC_NEx low to FEMC_NOE low | TBD | TBD | ns |

| | | | | |
|---------------------|---|-----|-----|----|
| $t_{w(NWE)}$ | FEMC_NOE low time | TBD | TBD | ns |
| $t_{h(NE_NWE)}$ | Hold time from FEMC_NOE high to FEMC_NE high | TBD | TBD | ns |
| $t_{v(A_NE)}$ | FEMC_NEx low to FEMC_A valid | TBD | TBD | ns |
| $t_{v(NADV_NE)}$ | Hold time of FEMC_AD (address) valid after FEMC_NADV high | TBD | TBD | ns |
| $t_{w(NADV)}$ | Address hold time after FEMC_NOE high | TBD | TBD | ns |
| $t_{h(AD_NADV)}$ | FEMC_NBL hold time after FEMC_NOE high | TBD | TBD | ns |
| $t_{h(A_NWE)}$ | FEMC_NEx low to FEMC_NBL valid | TBD | TBD | ns |
| $t_{v(BL_NE)}$ | Data setup time to FEMC_NEx high | TBD | TBD | ns |
| $t_{h(BL_NWE)}$ | Data setup time to FEMC_NOE high | TBD | TBD | ns |
| $t_{v(Data_NADV)}$ | Data hold time after FEMC_NEx high | TBD | TBD | ns |
| $t_{h(Data_NWE)}$ | Data hold time after FEMC_NOE high | TBD | TBD | ns |

Notes:

1. IO drive strength = 8 mA, capacitive load = 30 pF
2. Measurement point set at CMOS level: 0.5 VDD
3. $t_{HCLK} \geq 1 / 240 \text{ MHz}$

Synchronous Waveforms and Timing

Figures 4-30 to 4-33 show the synchronous waveforms, and Tables 4-54 to 4-57 provide the corresponding timing parameters.

Figure 4-31 Synchronous Non-Bus-Multiplexed NOR/PSRAM Read Timing

Table 4-56 Synchronous Non-Bus-Multiplexed NOR/PSRAM Read Timing⁽¹⁾⁽²⁾

| Symbol | Parameter | Min | Max | Unit |
|------------------------------|---|-----|-----|------|
| $t_{w(\text{CLK})}$ | FEMC_CLK period | 9.8 | - | ns |
| $t_{d(\text{CLKL-NExL})}$ | FEMC_CLK low to FEMC_NEx low ($x = 1 \dots 4$) | - | 2.0 | ns |
| $t_{d(\text{CLKL-NExH})}$ | FEMC_CLK low to FEMC_NEx high ($x = 1 \dots 4$) | 2.0 | | ns |
| $t_{d(\text{CLKL-NADV L})}$ | FEMC_CLK low to FEMC_NADV low | - | 2.0 | ns |
| $t_{d(\text{CLKL-NADV H})}$ | FEMC_CLK low to FEMC_NADV high | 2.0 | | ns |
| $t_{d(\text{CLKL-AV})}$ | FEMC_CLK low to FEMC_Ax valid ($x = 0 \dots 25$) | - | 3.0 | ns |
| $t_{d(\text{CLKL-AIV})}$ | FEMC_CLK low to FEMC_Ax invalid ($x = 0 \dots 25$) | 2.0 | | ns |
| $t_{d(\text{CLKL-NOEL})}$ | FEMC_CLK low to FEMC_NOE low | - | 2.0 | ns |
| $t_{d(\text{CLKL-NOEH})}$ | FEMC_CLK low to FEMC_NOE high | 2.0 | - | ns |
| $t_{su(\text{DV-CLKH})}$ | Data valid (FEMC_D[31:0]) setup time before FEMC_CLK high | 2.6 | - | ns |
| $t_h(\text{CLKH-DV})$ | Data valid (FEMC_D[31:0]) hold time after FEMC_CLK high | 0.3 | - | ns |
| $t_{su(\text{NWAITV-CLKH})}$ | FEMC_NWAIT valid setup time before FEMC_CLK high | 2.6 | - | ns |
| $t_h(\text{CLKH-NWAITV})$ | FEMC_NWAIT valid hold time after FEMC_CLK high | 0.3 | - | ns |

Notes:

1. IO drive strength: 8mA, Capacitive load = 30pF
2. Measurement point set at CMOS level: 0.5VDD

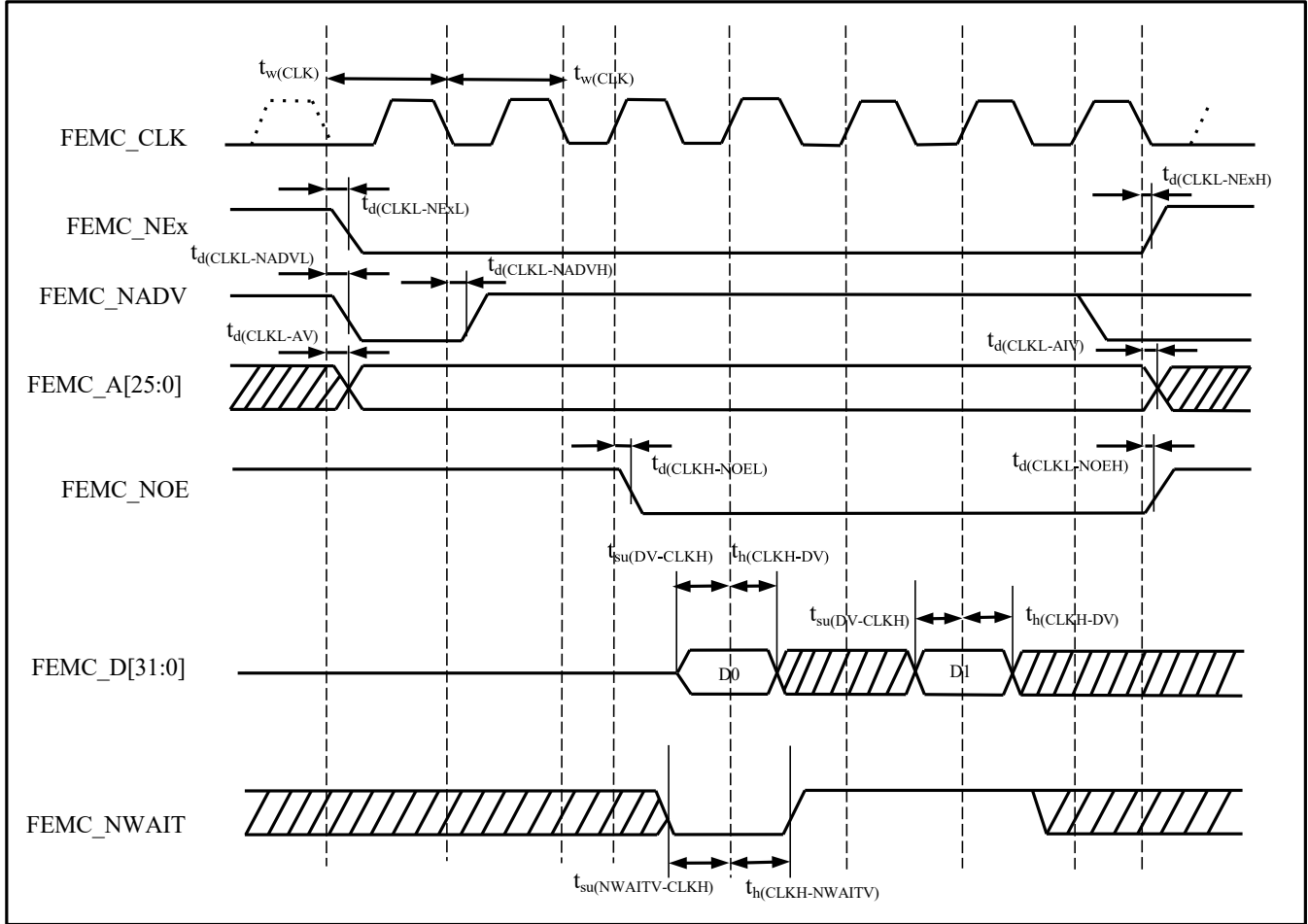
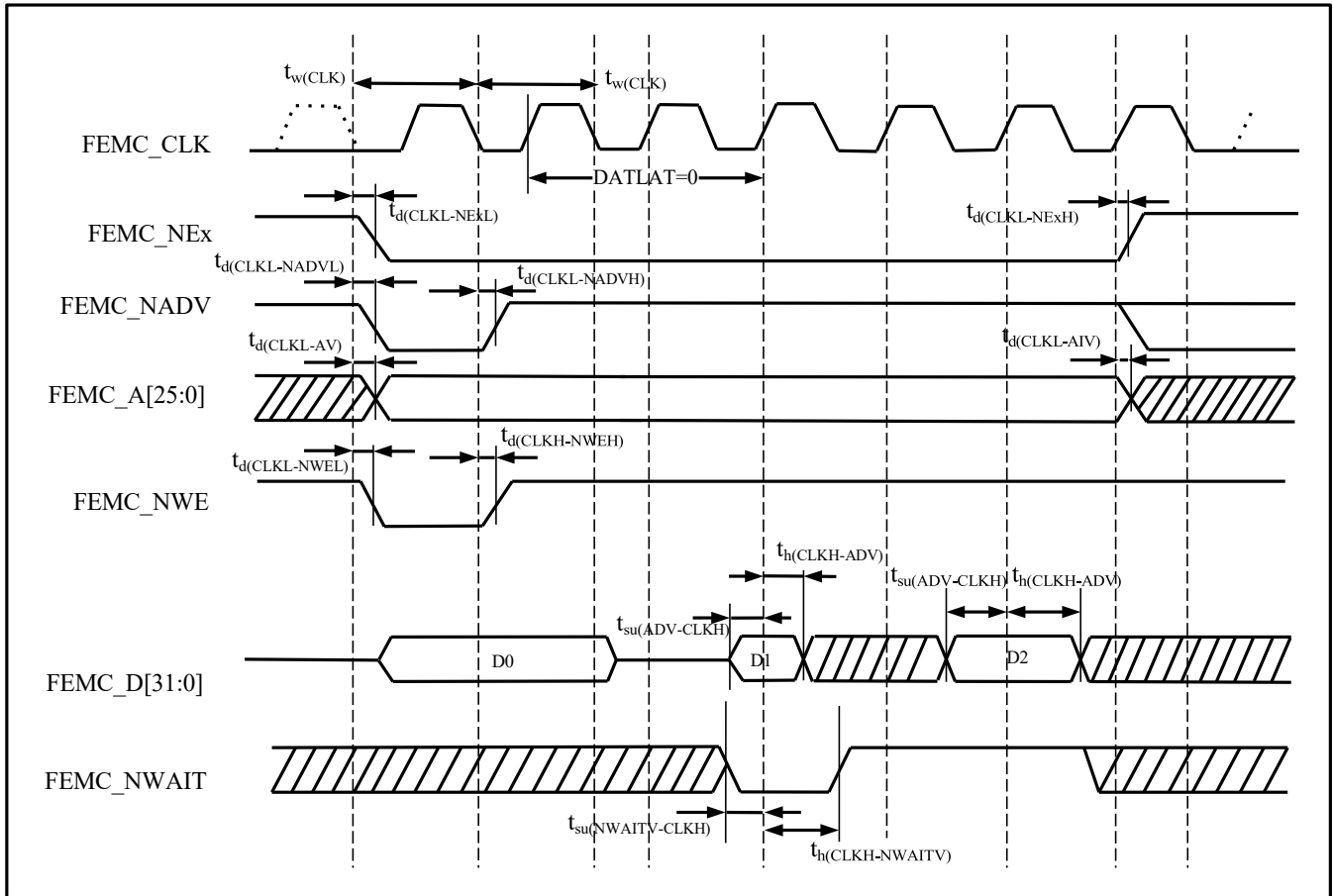
Figure 4-32 Synchronous Non-Multiplexed PSRAM Write Timing

Table 4-57 Synchronous Non-Multiplexed PSRAM Write Timing ⁽¹⁾⁽²⁾

| Symbol | Parameter | Min | Max | Unit |
|-----------------------|---|-----|-----|------|
| $t_{w(CLK)}$ | FEMC_CLK period | 9.8 | - | ns |
| $t_{d(CLKL-NExL)}$ | FEMC_CLK low to FEMC_NEx low ($x = 1 \dots 4$) | - | 2.0 | ns |
| $t_{d(CLKL-NExH)}$ | FEMC_CLK low to FEMC_NEx high ($x = 1 \dots 4$) | 2.0 | - | ns |
| $t_{d(CLKL-NADVL)}$ | FEMC_CLK low to FEMC_NADV low | - | 2.0 | ns |
| $t_{d(CLKL-NADVH)}$ | FEMC_CLK low to FEMC_NADV high | 2.0 | - | ns |
| $t_{d(CLKL-AV)}$ | FEMC_CLK low to FEMC_A _x valid ($x = 0 \dots 25$) | - | 3.0 | ns |
| $t_{d(CLKH-AIV)}$ | FEMC_CLK high to FEMC_A _x invalid ($x = 0 \dots 25$) | 2.0 | - | ns |
| $t_{d(CLKL-NWEL)}$ | FEMC_CLK low to FEMC_NWE low | - | 2.0 | ns |
| $t_{d(CLKH-NWEH)}$ | FEMC_CLK high to FEMC_NWE high | 2.0 | - | ns |
| $t_{d(CLKL-Data)}$ | FEMC_CLK low to FEMC_D[31:0] valid data | - | 3.0 | ns |
| $t_{su(NWAITV-CLKH)}$ | FEMC_NWAIT valid setup time before FEMC_CLK high | 2.6 | - | ns |
| $t_{h(CLKH-NWAITV)}$ | FEMC_NWAIT valid hold time after FEMC_CLK high | 0.3 | - | ns |

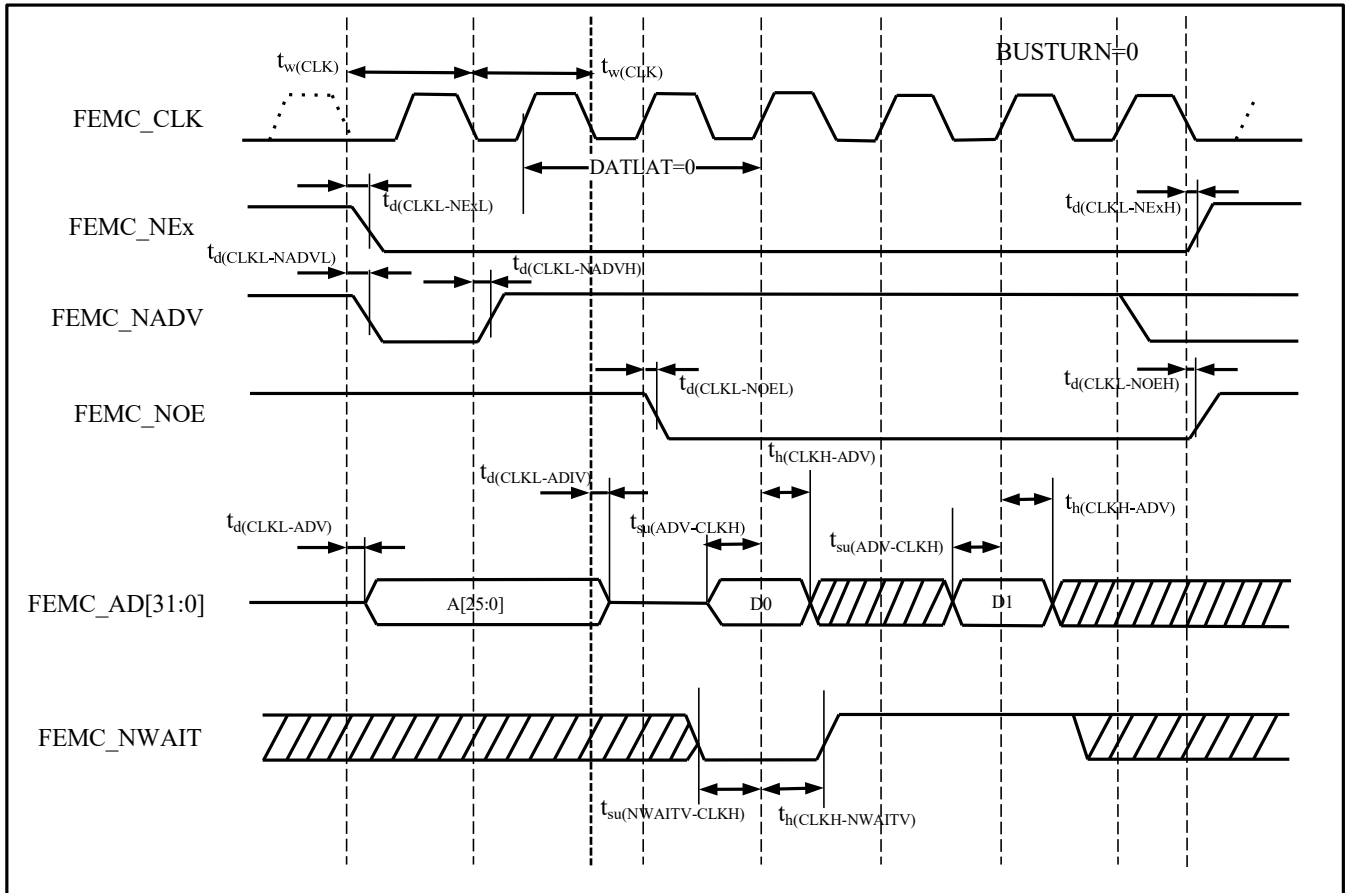
- IO drive strength: 8mA, Capacitive load = 30pF
- Measurement point set at CMOS level: 0.5VDD

Figure 4-33 Synchronous Bus-Multiplexed NOR/PSRAM Read Timing

Table 4-58 Synchronous Bus-Multiplexed NOR/PSRAM Read Timing ⁽¹⁾⁽²⁾

| Symbol | Parameter | Min ⁽³⁾ | Max | Unit |
|------------------------------|--|--------------------|-----|------|
| $t_w(\text{CLK})$ | FEMC_CLK period | 9.8 | - | ns |
| $t_d(\text{CLKL-NExL})$ | FEMC_CLK low to FEMC_NEx low ($x = 1 \dots 4$) | - | 2.0 | ns |
| $t_d(\text{CLKL-NExH})$ | FEMC_CLK low to FEMC_NEx high ($x = 1 \dots 4$) | 2.0 | - | ns |
| $t_d(\text{CLKL-NADVl})$ | FEMC_CLK low to FEMC_NADV low | - | 2.0 | ns |
| $t_d(\text{CLKL-NADVh})$ | FEMC_CLK low to FEMC_NADV high | 2.0 | - | ns |
| $t_d(\text{CLKL-NOEL})$ | FEMC_CLK low to FEMC_NOE low | - | 2.0 | ns |
| $t_d(\text{CLKL-NOEH})$ | FEMC_CLK low to FEMC_NOE high | 2.0 | - | ns |
| $t_d(\text{CLKL-ADV})$ | FEMC_CLK low to FEMC_AD[31:0] valid | - | 3.0 | ns |
| $t_d(\text{CLKL-ADIV})$ | FEMC_CLK low to FEMC_AD[31:0] invalid | 2.0 | - | ns |
| $t_{su}(\text{ADV-CLKH})$ | FEMC_AD[31:0] valid data setup time before FEMC_CLK high | 2.6 | - | ns |
| $t_h(\text{CLKH-ADV})$ | FEMC_AD[31:0] valid data hold time after FEMC_CLK high | 0.3 | - | ns |
| $t_{su}(\text{NWAITV-CLKH})$ | FEMC_NWAIT valid setup time before FEMC_CLK high | 2.6 | - | ns |
| $t_h(\text{CLKH-NWAITV})$ | FEMC_NWAIT valid hold time after FEMC_CLK high | 0.3 | - | ns |

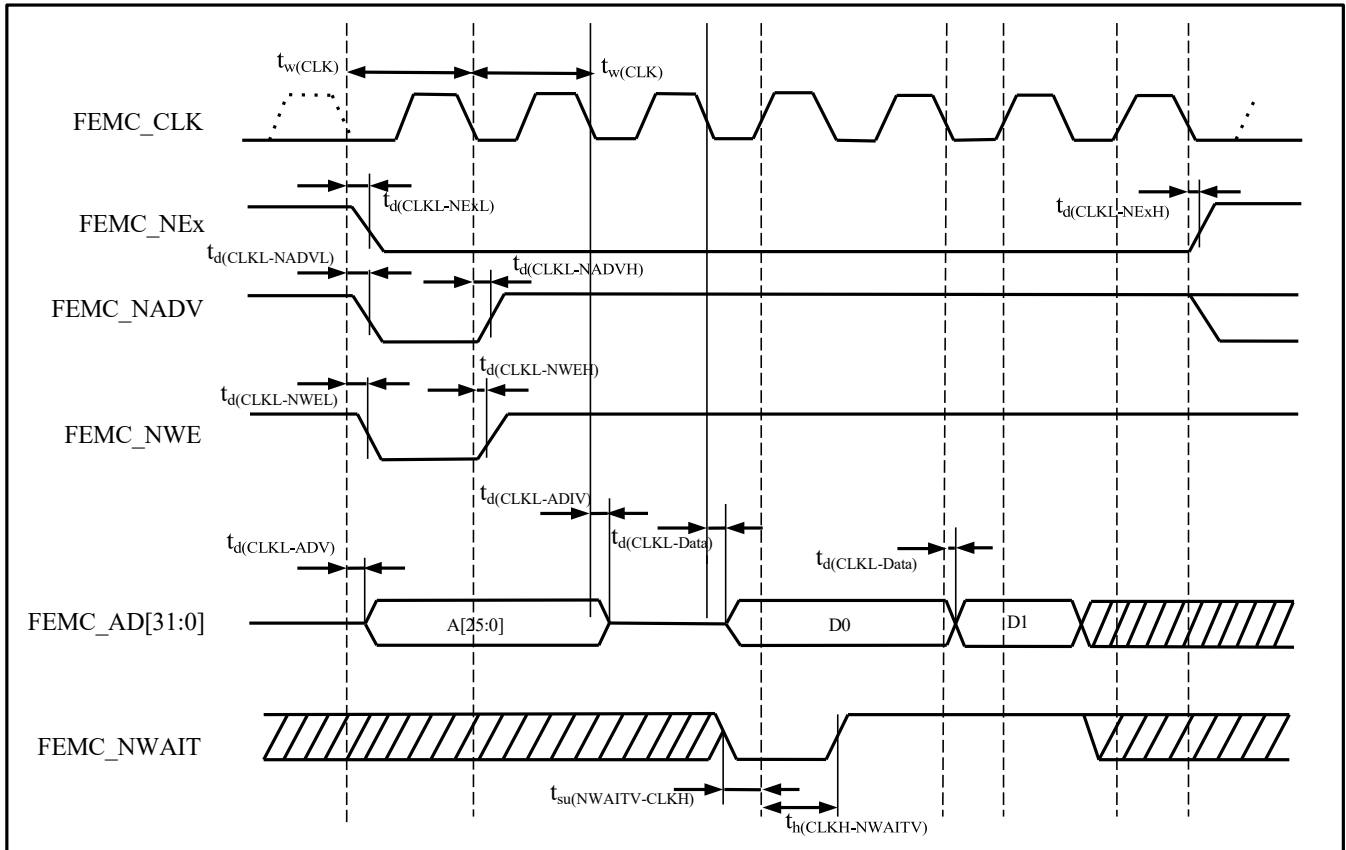
1. IO drive strength: 8mA, Capacitive load = 30pF
2. Measurement point set at CMOS level: 0.5VDD
3. $t_{HCLK} \geq 1/300\text{MHz}$

Figure 4-34 Synchronous Bus-Multiplexed PSRAM Write Timing

Table 4-59 Synchronous Multiplexed PSRAM Write Timing ⁽¹⁾⁽²⁾

| Symbol | Parameter | Min ⁽³⁾ | Max | Unit |
|------------------------------|---|--------------------|-----|------|
| $t_w(\text{CLK})$ | FEMC_CLK cycle | 9.8 | - | ns |
| $t_d(\text{CLKL-NExL})$ | FEMC_CLK low to FEMC_NEx low ($x = 1 \dots 4$) | - | 2.0 | ns |
| $t_d(\text{CLKL-NExH})$ | FEMC_CLK low to FEMC_NEx high ($x = 1 \dots 4$) | 2.0 | - | ns |
| $t_d(\text{CLKL-NADV})$ | FEMC_CLK low to FEMC_NADV low | - | 2.0 | ns |
| $t_d(\text{CLKL-NADVH})$ | FEMC_CLK low to FEMC_NADV high | 2.0 | - | ns |
| $t_d(\text{CLKL-NWEL})$ | FEMC_CLK low to FEMC_NWE low | - | 2.0 | ns |
| $t_d(\text{CLKL-NWEH})$ | FEMC_CLK low to FEMC_NWE high | 2.0 | - | ns |
| $t_d(\text{CLKL-ADV})$ | FEMC_CLK low to FEMC_AD[31:0] valid | - | 3.0 | ns |
| $t_d(\text{CLKL-ADIV})$ | FEMC_CLK low to FEMC_AD[31:0] invalid | 2.0 | - | ns |
| $t_d(\text{CLKL-Data})$ | FEMC_CLK low then FEMC_AD[31:0] valid | - | 3.0 | ns |
| $t_{su}(\text{NWAITV-CLKH})$ | FEMC_CLK high before FEMC_NWAIT valid | 2.6 | - | ns |
| $t_h(\text{CLKH-NWAITV})$ | FEMC_CLK high after FEMC_NWAIT valid | 0.3 | - | ns |

Notes:

- IO drive capability 8mA, Capacitive load = 30 pF
- Measurement points at CMOS level: 0.5VDD
- $t_{HCLK} \geq 1/300\text{MHz}$

- NAND Controller Waveforms and Timing**

Figures 4-34 to 4-35 show the waveforms for NAND operations.

Figure 4-35 NAND Controller Read Operation Waveform

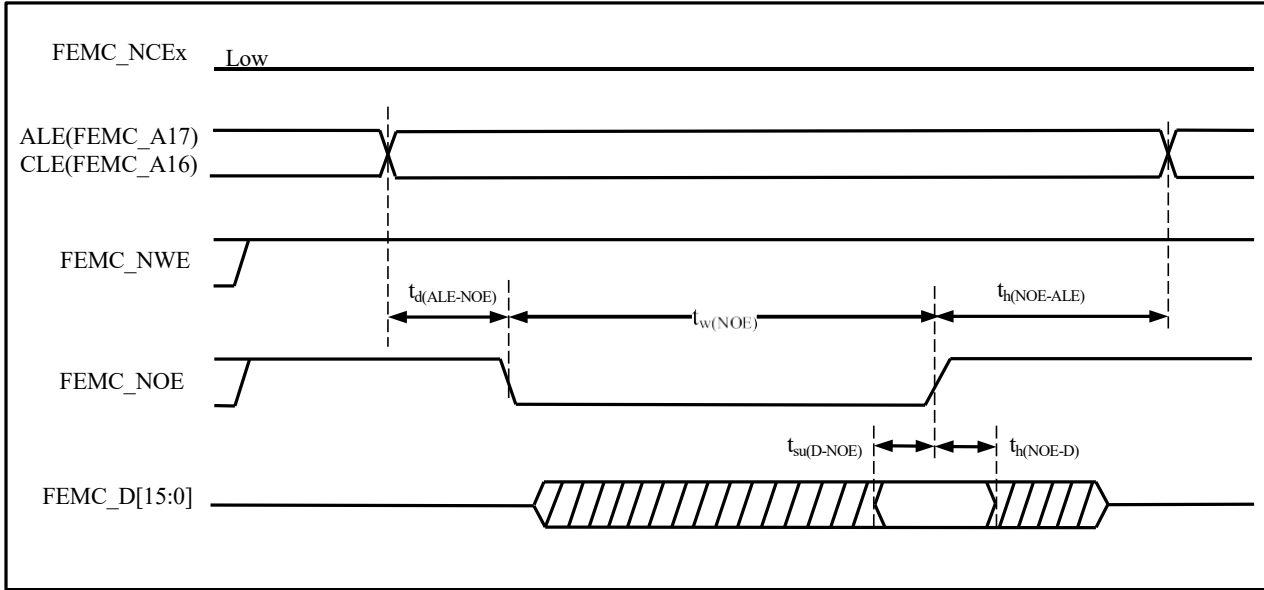

Figure 4-36 NAND Controller Write Operation Waveform

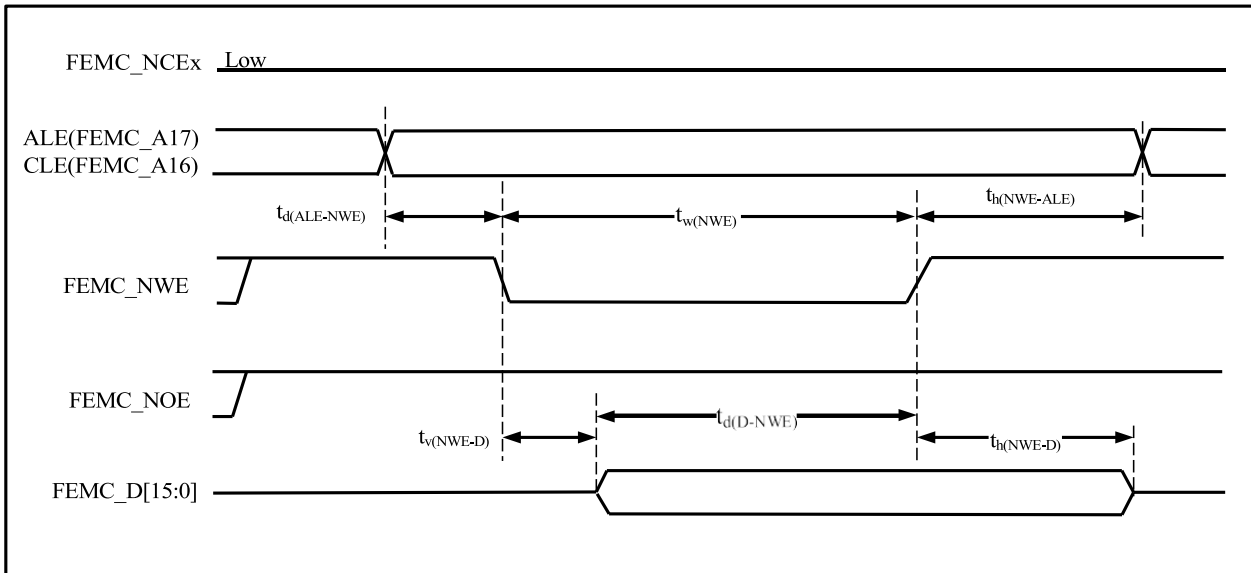

Table 4-60 NAND Flash Read Cycle Timing Characteristics ⁽¹⁾

| Symbol | Parameter | Min | Max | Unit |
|-----------------|--------------------------------------|-----|-----|------|
| $t_{w(NOE)}$ | FEMC_NOE low time | TBD | TBD | ns |
| $t_{su(D-NOE)}$ | Data valid before FEMC_NOE goes high | TBD | TBD | ns |

| | | | | |
|------------------|--------------------------------------|-----|-----|----|
| $t_{h(NOE-D)}$ | Data valid after FEMC_NOE goes high | TBD | TBD | ns |
| $t_{d(ALE-NOE)}$ | ALE valid before FEMC_NOE goes low | TBD | TBD | ns |
| $t_{h(NOE-ALE)}$ | ALE invalid after FEMC_NOE goes high | TBD | TBD | ns |

Note: Guaranteed by design, not tested in production.

Figure 4-37 NAND Controller Read Operation Waveform

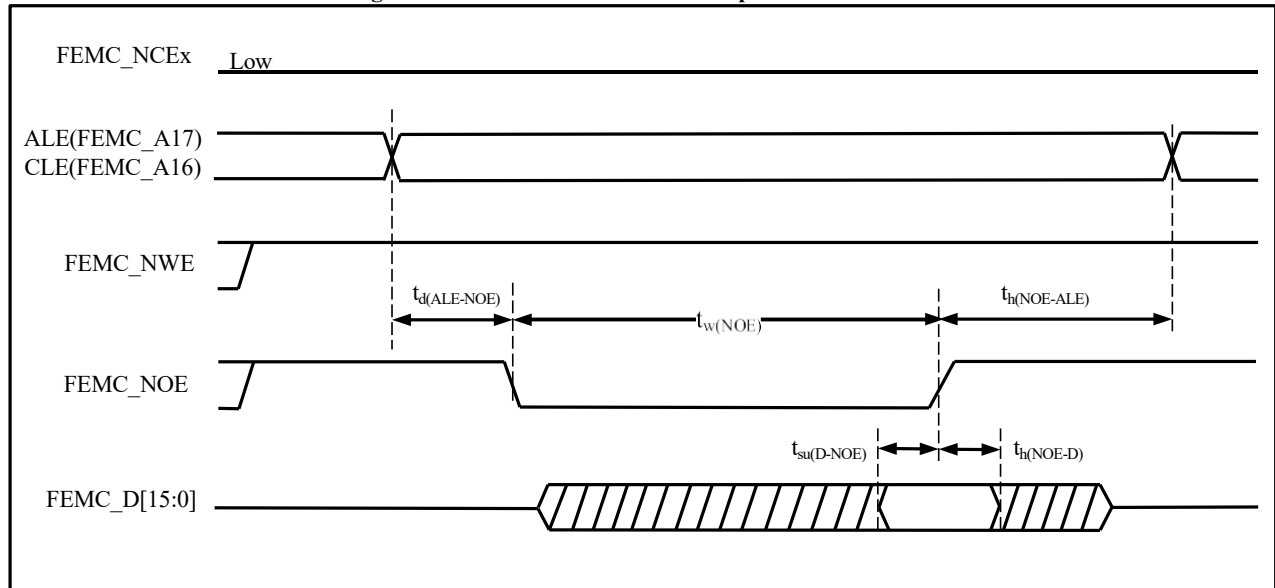

Figure 4-38 NAND Controller Write Operation Waveform

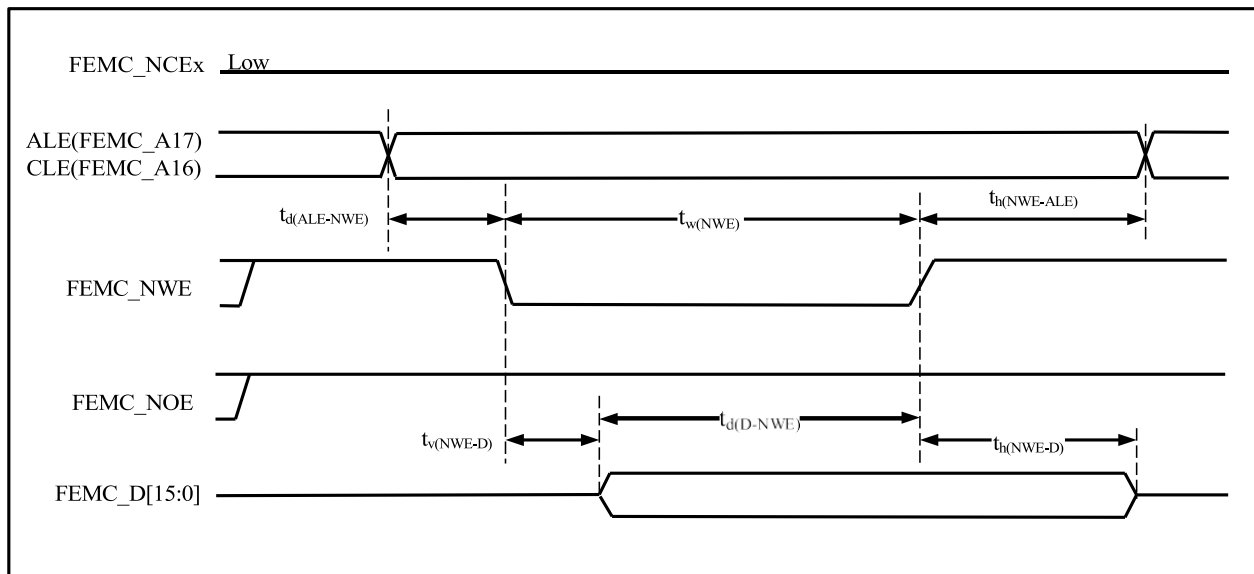

Table 4-61 NAND Flash Read Cycle Timing Characteristics ⁽¹⁾

| Symbol | Parameter | Min | Max | Unit |
|-----------------|--------------------------------------|-----|-----|------|
| $t_w(NOE)$ | FEMC_NOE low time | TBD | TBD | |
| $t_{su}(D-NOE)$ | Data valid before FEMC_NOE goes high | TBD | TBD | |

| | | | | |
|------------------|--------------------------------------|-----|-----|--|
| $t_{h(NOE-D)}$ | Data valid before FEMC_NOE goes high | TBD | TBD | |
| $t_{d(ALE-NOE)}$ | ALE valid before FEMC_NOE goes low | TBD | TBD | |
| $t_{h(NOE-ALE)}$ | ALE invalid after FEMC_NOE goes high | TBD | TBD | |

Note: Guaranteed by design, not tested in production.

Figure 4-39 NAND Controller Read Operation Waveform

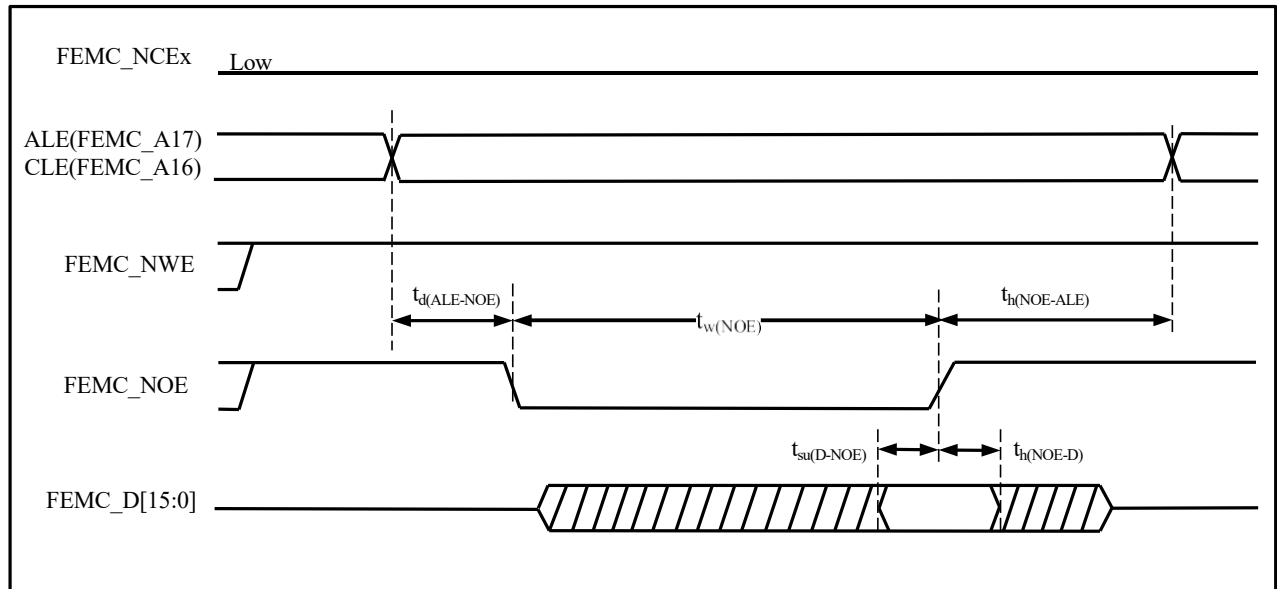

Figure 4-40 NAND Controller Write Operation Waveform

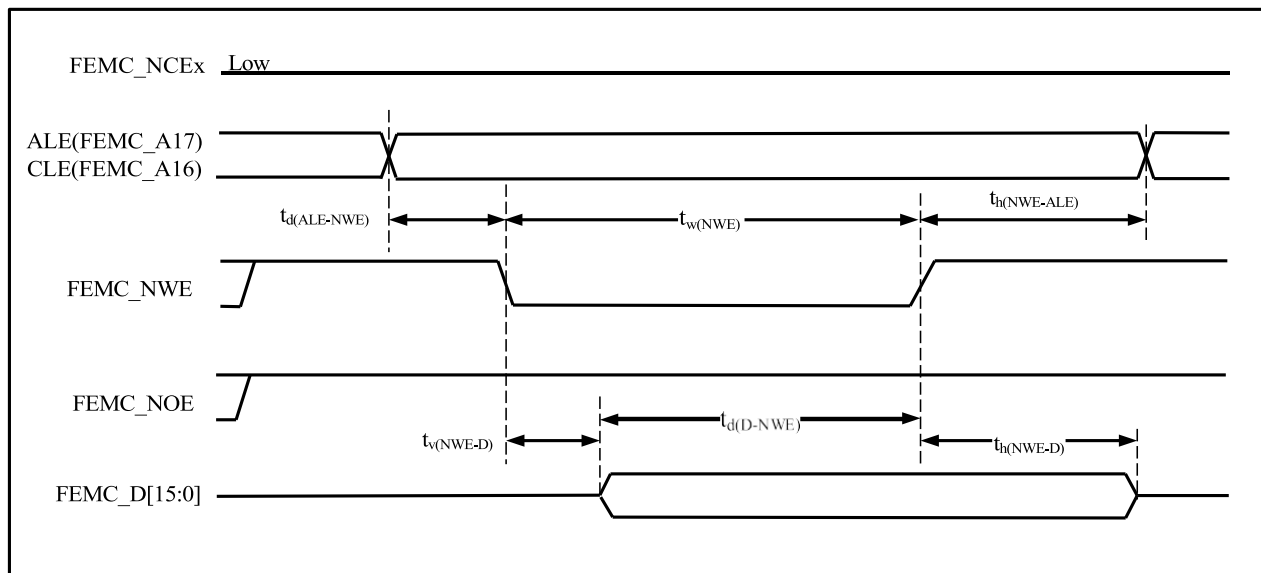

Table 4-62 NAND Flash Read Cycle Timing Characteristics ⁽¹⁾

| Symbol | Parameter | Min | Max | Unit |
|-----------------|--------------------------------------|-----|-----|------|
| $t_{w(NOE)}$ | FEMC_NOE low time | TBD | TBD | ns |
| $t_{su(D-NOE)}$ | Data valid before FEMC_NOE goes high | TBD | TBD | ns |

| | | | | |
|------------------|--------------------------------------|-----|-----|----|
| $t_{h(NOE-D)}$ | Data valid after FEMC_NOE goes high | TBD | TBD | ns |
| $t_{d(ALE-NOE)}$ | ALE valid before FEMC_NOE goes low | TBD | TBD | ns |
| $t_{h(NOE-ALE)}$ | ALE invalid after FEMC_NOE goes high | TBD | TBD | ns |

Note: Guaranteed by design, not tested in production.

Table 4-63 NAND Flash Read/Write Cycle Timing Characteristics ⁽¹⁾

| Symbol | Parameter | Min | Max | Unit |
|------------------|---------------------------------------|-----|-----|------|
| $t_{d(D-NWE)}$ | Data valid before FEMC_NWE goes high | TBD | TBD | ns |
| $t_{w(NOE)}$ | FEMC_NOE low time | TBD | TBD | ns |
| $t_{su(D-NOE)}$ | Data valid before FEMC_NOE goes high | TBD | TBD | ns |
| $t_{h(NOE-D)}$ | Data valid after FEMC_NOE goes high | TBD | TBD | ns |
| $t_{w(NWE)}$ | FEMC_NWE low time | TBD | TBD | ns |
| $t_{v(NWE-D)}$ | Data valid after FEMC_NWE goes low | TBD | TBD | ns |
| $t_{h(NWE-D)}$ | Data invalid after FEMC_NWE goes high | TBD | TBD | ns |
| $t_{d(ALE-NWE)}$ | ALE valid before FEMC_NWE goes low | TBD | TBD | ns |
| $t_{h(NWE-ALE)}$ | ALE invalid after FEMC_NWE goes high | TBD | TBD | ns |
| $t_{d(ALE-NOE)}$ | ALE valid before FEMC_NOE goes low | TBD | TBD | ns |
| $t_{h(NOE-ALE)}$ | ALE invalid after FEMC_NOE goes high | TBD | TBD | ns |

Note: Guaranteed by design, not tested in production.

4.3.23 USB_HS_DualRole Characteristics

Table 4-64 USBHS DC Electrical Characteristics

| Symbol | Parameter | Conditions | Min | Typ | Max | Unit | |
|-------------------------------|------------------------|---|------------------------------------|-----|-----|------------|-----|
| $V_{DD}^{(1)}$ | USB Operating Voltage | - | 3 | - | 3.6 | V | |
| LS/FS FUNCTIONALITY | | | | | | | |
| Input Voltage ⁽¹⁾ | V_{DIFS} | Differential Input Sensitivity (FS/LS) | - | 0.2 | - | V | |
| | V_{CMFS} | Differential Common-Mode Range (FS/LS) | 包括 VDI 范围 | 0.8 | - | | 2.5 |
| | V_{ILSE} | Single-Ended Receive Low Voltage (FS/LS) | - | - | - | | 0.8 |
| | V_{IHSE} | Single-Ended Receive High Voltage (FS/LS) | - | 2.0 | - | | - |
| Output Voltage ⁽¹⁾ | V_{OLFS} | Static Output Low Level (FS/LS) | R_L of 1.5k Ω to 3.6V | - | - | 0.3 | |
| | V_{OHFS} | Static Output High Level (FS/LS) | R_L of 15 k Ω to V_{SS} | 2.8 | 3.3 | 3.6 | |
| $R_{PD}^{(1)}$ | USBHS_DM/DP | $V_{IN} = V_{DD}$ | - | 15 | - | k Ω | |
| $R_{PU}^{(1)}$ | USBHS_DM/DP | $V_{IN} = V_{SS}$ | - | 1.5 | - | | |
| $Z_{HSDRV}^{(1)}$ | Drive Output Impedance | Steady state drive | - | 45 | - | Ω | |
| HS FUNCTIONALITY | | | | | | | |
| Input Voltage ⁽¹⁾ | D_{IHS} | Differential Input Sensitivity (HS) | - | 0.1 | - | V | |

| | | | | | | | |
|-------------------------------|--------|--------------------------------------|----------|-----|-----|-----|----|
| | VCMHS | Differential Common-Mode Range (HS) | - | -50 | - | 500 | mV |
| | VHSSQ | HS Squelch Detection Threshold | - | 100 | - | 150 | |
| | VHSDSC | HS Disconnect Threshold | - | 525 | - | 625 | |
| Output Voltage ⁽¹⁾ | VOLHS | High-Speed Low-Level Output Voltage | 45Ω load | -10 | - | 10 | |
| | VOHHS | High-Speed High-Level Output Voltage | 45Ω load | 360 | 400 | 440 | |

Note: Guaranteed by design, not tested in production.

Table 4-65 USBHS Dynamic Characteristics⁽¹⁾

| Symbol | Parameter | Conditions | Min | Typ | Max | Unit |
|--------|--|------------|-----|-----|-----|------|
| TFR | Rise Time (FS/LS) | CL = 50 pF | 4 | - | 20 | ns |
| THSR | Differential Rise Time (HS) | - | 500 | - | - | ps |
| TFF | Fall Time (FS/LS) | CL = 50 pF | 4 | - | 20 | ns |
| THSF | Differential Fall Time (HS) | - | 500 | - | - | ps |
| VCRS | Output Single Crossing Voltage (FS/LS) | - | 1.3 | - | 2 | V |

Note: Guaranteed by design, not tested in production

4.3.24 Controller Area Network (CAN) Electrical Characteristics

For detailed characteristics of the input/output multiplexed pins (CAN_TX and CAN_RX), refer to section 4.3.12.

4.3.25 Secure Digital Multimedia Card (SDMMC) Characteristics

Unless otherwise specified, the parameters in Table 4-59 are measured under the environmental temperature, fHCLK frequency, and VDDA supply voltage conditions defined in Table 4-4.

Table 4-66 SD/MMC Characteristics, VDD = 2.7V to 3.6V⁽¹⁾⁽²⁾

| Symbol | Parameter | Conditions | Min | Typ | Max | Unit |
|---|---------------------------------------|--------------------------|------|-----|------|------|
| f _{pp} | Clock frequency in data transfer mode | - | - | - | 104 | MHz |
| t _{w(CKL)} | Clock low time | f _{pp} =50MHz | 8.6 | 9.6 | - | ns |
| t _{w(CKH)} | Clock high time | | 8.6 | 9.6 | - | ns |
| CMD, D input in MMC Legacy/SDR/DDR and SD HS/SDR/DDR modes (referenced to CK) | | | | | | |
| t _{ISU} | Input setup time HS | f _{pp} ≥ 50 MHz | 2.87 | - | - | ns |
| t _{IH} | Input hold time HS | | 1.3 | - | - | ns |
| t _{IDW} ⁽³⁾ | v | | TBD | - | - | ns |
| CMD, D output in MMC Legacy/SDR/DDR and SD HS/SDR/DDR modes (referenced to CK) | | | | | | |
| t _{OV} | Output valid dataHS | f _{pp} ≥ 50 MHz | - | - | 2.74 | ns |

| | | | | | | |
|---|------------------------------|------------------------|------|---|------|----|
| t _{OH} | Output hold timeHS | | 3.0 | - | - | ns |
| CMD, D input in SD default mode (referenced to CK) | | | | | | |
| t _{ISUD} | Input setup time SD | f _{pp} =25MHz | 2.87 | - | - | ns |
| t _{IHD} | Input hold time SD | | 1.3 | - | - | ns |
| CMD, D output in SD default mode (reference CK) | | | | | | |
| t _{OVd} | Output valid default time SD | f _{pp} =25MHz | - | - | 2.74 | ns |
| t _{OHd} | Output hold default time SD | | 3.0 | - | - | ns |

CMD, D output in SD default mode (reference CK)

1. Guaranteed by design, not tested in production.
2. CL = 20 pF.
3. In tuning mode, minimum time window where data must remain stable for correct sampling.

Table 4-67 eMMC Characteristics, VDD=1.71 to 1.9V ⁽¹⁾⁽²⁾

| Symbol | Parameter | Conditions | Min | Typ | Max | Unit |
|--|---------------------------------------|--------------------------|-----|-----|-----|------|
| f _{pp} | Clock frequency in data transfer mode | - | TBD | TBD | TBD | MHz |
| t _{w(CKL)} | Clock low time | f _{pp} =50MHz | TBD | TBD | TBD | ns |
| t _{w(CKH)} | Clock high time | | TBD | TBD | TBD | ns |
| CMD, D input in eMM mode (referenced to CK) | | | | | | |
| t _{ISU} | Input setup time HS HS | f _{pp} ≥ 50 MHz | TBD | TBD | TBD | ns |
| t _{IH} | Input hold time HS | | TBD | TBD | TBD | ns |
| t _{IDW} ⁽³⁾ | Input valid window (variable window) | | TBD | TBD | TBD | ns |
| CMD, D output in eMMC mode (reference CK) | | | | | | |
| t _{ov} | Output valid dataHS | f _{pp} ≥ 50 MHz | TBD | TBD | TBD | ns |
| t _{oh} | Output hold timeHS | | TBD | TBD | TBD | ns |

1. Guaranteed by design, not tested in production.
2. CL = 20 pF.
3. In tuning mode, minimum time window where data must remain stable for correct sampling.

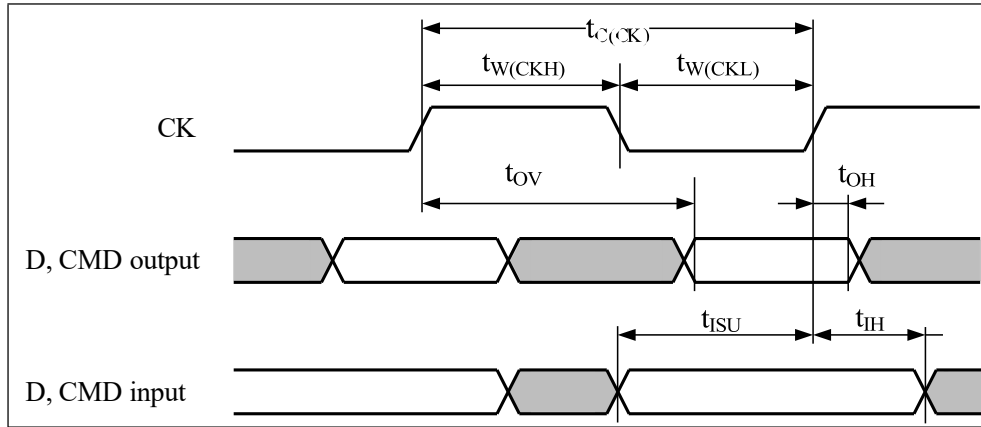
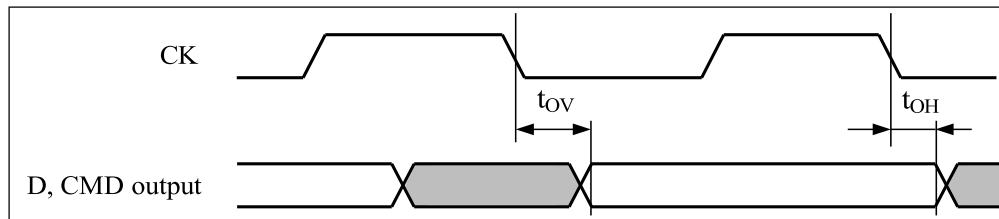
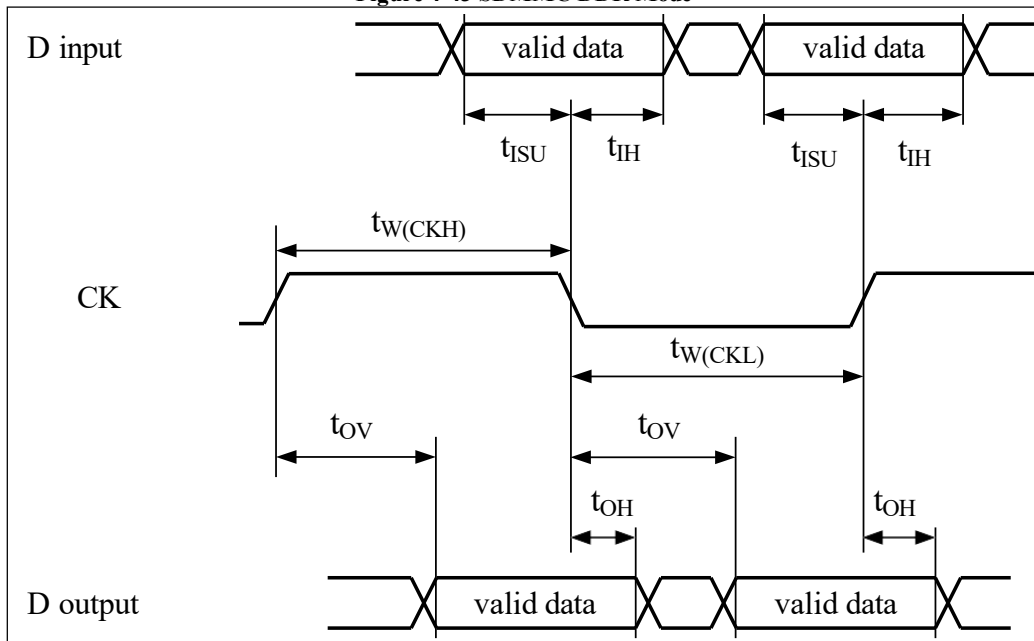
Figure 4-41 SD High-Speed Mode

Figure 4-42 SDMMC DDR Mode

Figure 4-43 SDMMC DDR Mode

4.3.26 Ethernet Interface Characteristics

Unless otherwise specified, parameters in Tables 4-66, 4-67, 4-68 are measured under the environmental temperature (25°C), fHCLK frequency, and VDD supply voltage defined in Table 4-4.

Table 4-68 MDIO/SMA Timing

| Symbol | Parameter | Min | Typ | Max | Unit |
|-----------|---------------------------|-----|-----|-----|------|
| t_{MDC} | MDC period time (2.5 MHz) | - | 2.5 | - | MHz |

| Symbol | Parameter | Min | Typ | Max | Unit |
|----------------|------------------------|-----|-----|-----|------|
| $t_{d(MDIO)}$ | Valid write data delay | - | - | 5 | ns |
| $t_{su(MDIO)}$ | Read data setup time | 17 | - | - | ns |
| $t_{h(MDIO)}$ | Read data hold time | 0 | - | - | ns |

Figure 4-44 MDIO/SMA Timing Diagram

Table 4-67 lists the RMI Ethernet MAC timing parameters, and Figure 4-44 shows the corresponding timing diagram.

Table 4-69 RMI Timing

| Symbol | Parameter | Min | Typ | Max | Unit |
|-------------------|-------------------------------------|-----|-----|-----|------|
| $t_{su(RXD)}$ | Receive data setup time | 2 | - | - | ns |
| $t_{ih(RXD)}$ | Receive data hold time | 1.6 | - | - | ns |
| $t_{su(CRS_DV)}$ | Carrier sense/data valid setup time | 2 | - | - | ns |
| $t_{ih(CRS_DV)}$ | Carrier sense/data valid hold time | 1.6 | - | - | ns |
| $t_{d(TXEN)}$ | Transmit enable valid delay time | - | - | 9.3 | ns |
| $t_{d(TXD)}$ | Transmit data valid delay time | - | - | 9.3 | ns |

Figure 4-45 RMI Timing Diagram

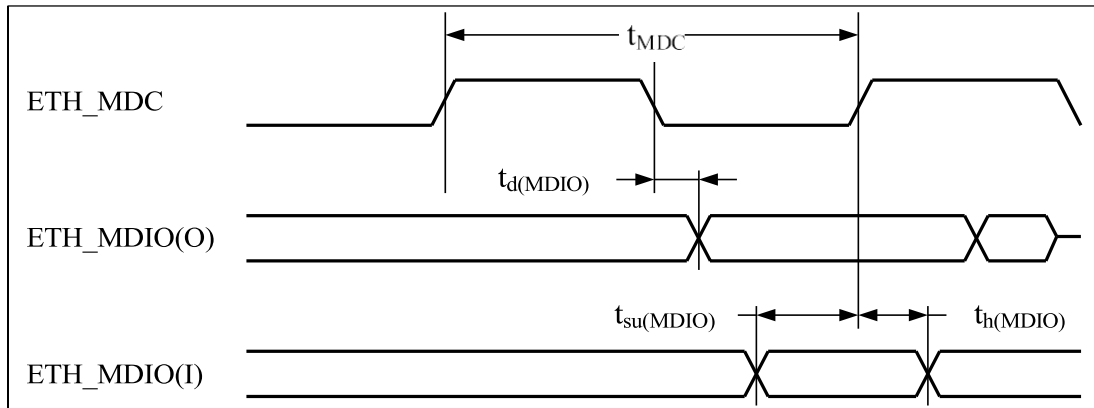
Table 4 68 lists the Ethernet MAC timing of MII and Figure 4 45 shows the corresponding timing diagram.

Table 4-70 MII Timing

| Symbol | Parameter | Min | Typ | Max | Unit |
|---------------|----------------------------------|-----|-----|------|------|
| $t_{su}(RXD)$ | Receive data setup time | 2.5 | - | - | ns |
| $t_{ih}(RXD)$ | Receive data hold time | 0.5 | - | - | ns |
| $t_{su}(DV)$ | Data valid setup time | 2.5 | - | - | ns |
| $t_{ih}(DV)$ | Data valid hold time | 0.5 | - | - | ns |
| $t_{su}(ER)$ | Error setup time | 2.5 | - | - | ns |
| $t_{ih}(ER)$ | Error hold time | 0.5 | - | - | ns |
| $t_d(TXEN)$ | Transmit enable valid delay time | - | - | 12.0 | ns |
| $t_d(TXD)$ | Transmit data valid delay time | - | - | 12.0 | ns |

Figure 4-46 MII Timing Diagram

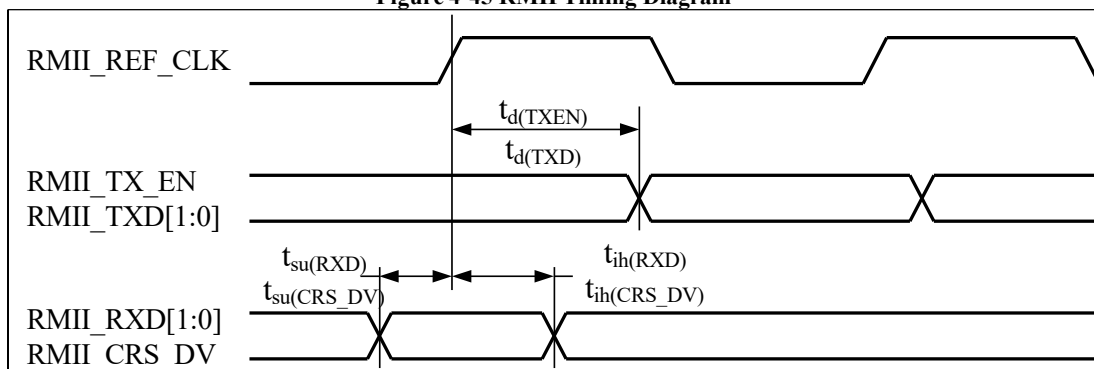
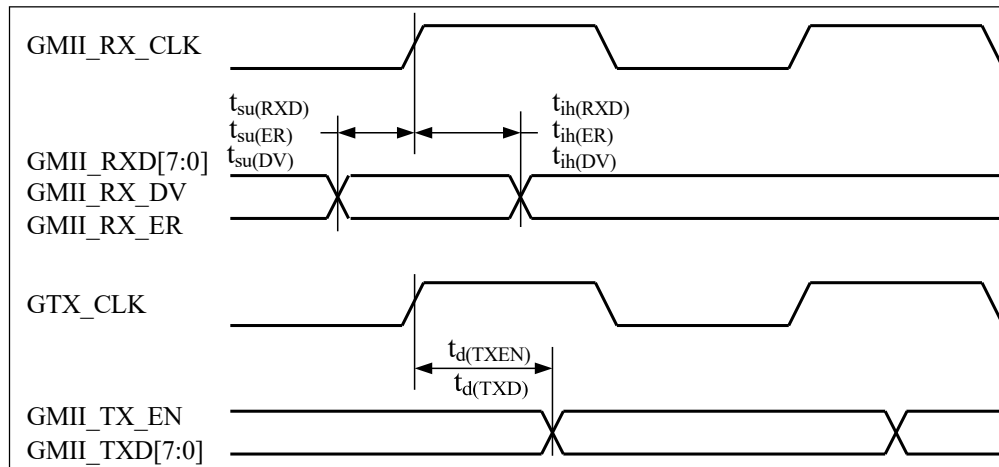
4.3.27 ESC Characteristics

Unless specifically stated, the parameters listed in **Table 4-72**, **Table 4-73**, **Table 4-74**, and **Table 4-75** are measured under the environmental temperature, **fHCLK** frequency, and **VDD** supply voltage conditions as specified in **Table 4-4**.

Table 4-72 lists the timing parameters for the ESC Management Interface (MI), and **Figure 4-48** shows the corresponding timing diagram.

Table 4-72 ESC MI (MCLK, MDIO) Timing

| Symbol | Parameter | Min | Typical | Max | Unit |
|-----------------|----------------------|-----|---------|-----|------------|
| tMCLK | MCLK Period | 400 | - | - | ns |
| tMCLK_h | MCLK High Level Time | 40 | 50 | 60 | % (period) |
| tMCLK_l | MCLK Low Level Time | 40 | 50 | 60 | % (period) |
| tD_setup | MDIO Setup Time | 100 | - | - | ns |

| Symbol | Parameter | Min | Typical | Max | Unit |
|-----------------|------------------------------|-----|---------|-----|------|
| tD_hold | MDIO Hold Time (Output) | 80 | - | - | ns |
| tD_valid | MDIO Data Valid Time (Input) | - | - | 50 | ns |

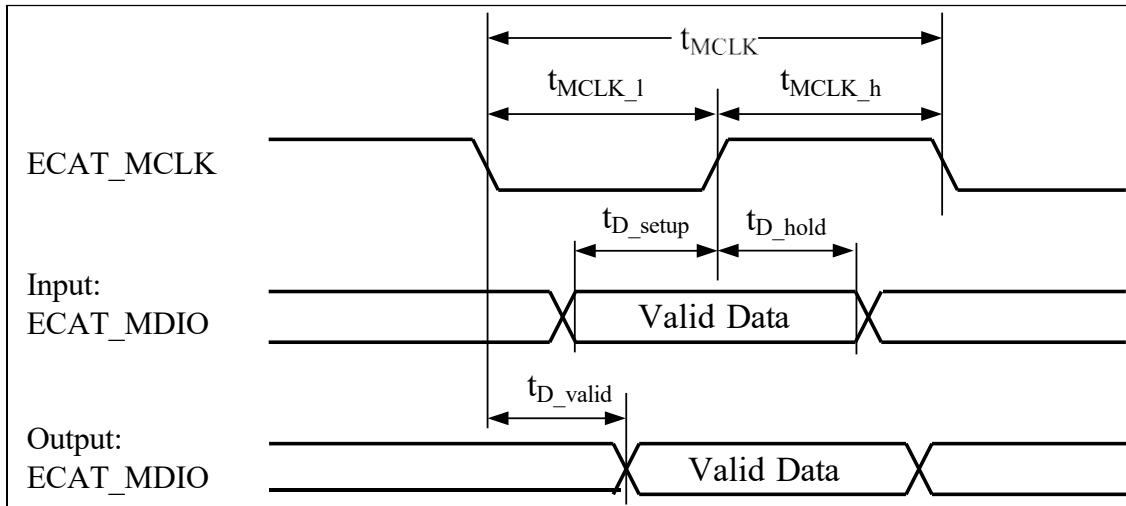
Figure 4-48 ESC MI (MCLK, MDIO) Timing Diagram

Table 4-73 ESC MII TX Signal Timing

| Symbol | Parameter | Min | Typical | Max | Unit |
|----------------------|---|-----|---------|-----|------|
| tTX_CLK | PHY_CLK25, TX_CLK Period | 40 | - | - | ns |
| tPHY_delay | Delay between PHY clock source PHY_CLK25 and TX_CLK output of the PHY | TBD | TBD | TBD | ns |
| tPHY_TX_setup | PHY Setup Requirement: TXEN/TXD[3:0] relative to TX_CLK | 18 | - | - | ns |
| tPHY_TX_hold | PHY Hold Requirement: TXEN/TXD[3:0] relative to TX_CLK | 11 | - | - | ns |

Figure 4-49 ESC MII TX Signal Timing Diagram

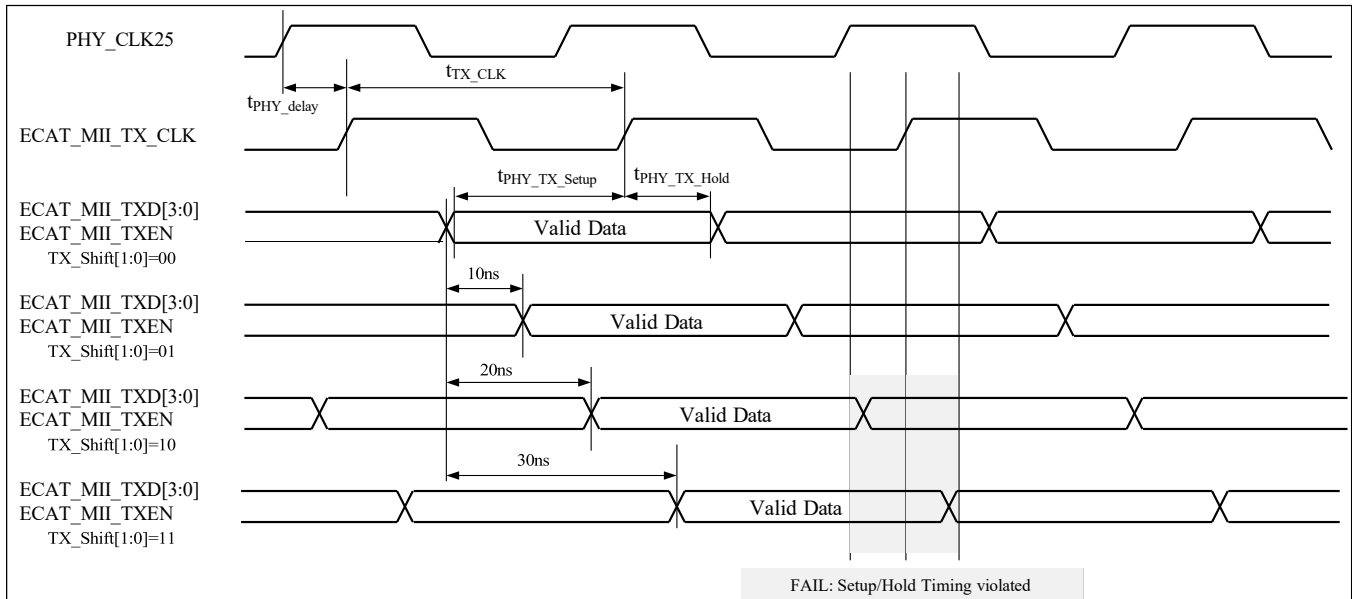

Table 4-74 lists the timing parameters for the ESC MII receive signals, and **Figure 4-50** shows the corresponding timing diagram.

Table 4-74 ESC MII RX Signal Timing

| Symbol | Parameter | Min | Typical | Max | Unit |
|-----------------|---|-----|---------|-----|------|
| t_{RX_CLK} | RX_CLK Period | 40 | - | - | ns |
| t_{RX_setup} | RX_DV/RX_DV/RXD[3:0] valid before the rising edge of RX_CLK | 10 | - | - | ns |
| t_{RX_hold} | RX_DV/RX_DV/RXD[3:0] valid after the rising edge of RX_CLK | 2 | - | - | ns |

Table 4-75 lists the timing parameters for the ESC Sync/Latch signals, and **Figure 4-51** shows the corresponding timing diagram.

Table 4-75 ESC Sync/Latch Signal Timing

| Symbol | Parameter | Min | Typ | Max | Unit |
|------------------------|-----------|-----|-----|-----|------|
| $t_{DC_SYNC_Jitter}$ | SYNC0/1 | TBD | TBD | TBD | Ns |
| t_{DC_LATCH} | LATCH0/1 | TBD | TBD | TBD | ns |

Figure 4-51 ESC Sync/Latch Signal Timing Diagram

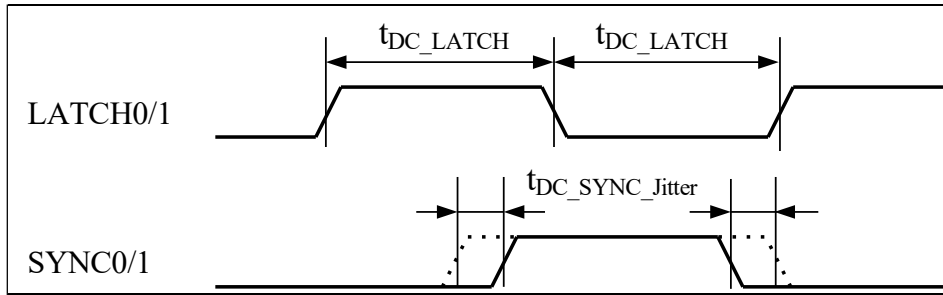

4.3.28 Digital Video Port (DVP) Interface

Table 4-76 shows the characteristics of the DVP interface signals, and Figure 4-52 illustrates the related timing.

Figure 4-52 DVP Interface Timing

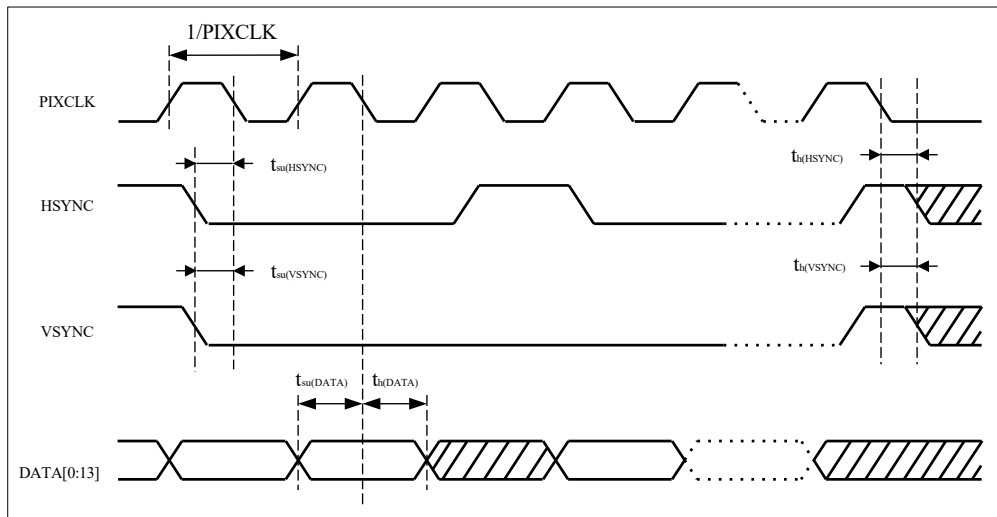

Table 4-76 DVP Signal Dynamic Characteristics

| Symbol | Parameter | Conditions | Min | Max | Unit |
|--------------------------------------|------------------------------|------------|-----|-----|------|
| PCLK | Pixel clock input | - | - | 110 | MHz |
| Dpixel | Pixel clock input duty cycle | - | 30 | 70 | - |
| $t_{su}(DATA)$ | Data input setup time | - | 3 | - | ns |
| $t_h(DATA)$ | Data input hold time | - | 1 | - | |
| $t_{su}(HSYNC)$, $t_{su}(VSYNC)$ | HSYNC/VSYNC input setup time | - | 3 | - | |
| $t_h(HSYNC)$, $t_h(VSYNC)$ | HSYNC/VSYNC input hold time | - | 1 | - | |

4.3.29 Digital Filter Unit Based on Σ - Δ Modulator (DSMU) Characteristics

Unless otherwise specified, the **Parameters** in Table 4-77 are measured under the environmental conditions (ambient temperature 25 °C, fHCLK frequency, and VDD supply voltage) conforming to Table 4-4. Additional test conditions are as follows:

- Port switching speed configuration: DSy[1:0] = 2b10, SRy = 1b0
- Load capacitance CL = 30 pF
- Reference CMOS level standards, I/O measurement point at 0.5 VDD

For more details on the characteristics of ports (DSMU_CKINx, DSMU_DATINx, DSMU_CKOUT), please refer to the I/O Port Characteristics section 4.3.12.

Table 4-77 DSMU Timing Parameters

| Symbol | Parameter | Conditions | | Min | Typ | Max | Unit |
|--------------------------------------|---|--|-----|-----|-----|-----|------|
| f_{DSMU} (1/T _{DSMU}) | DSMU clock | 2.3V < VDD < 3.63V | | TBD | TBD | TBD | |
| f_{CKIN} (1/T _{CKIN}) | Input clock frequency | 2.3V < VDD < 3.63V, SPI interface (SITP[1:0] = 0,1), external clock mode (SPICLKSEL[1:0] = 0) | | TBD | TBD | TBD | MHz |
| | | 2.3V < VDD < 3.63V, SPI interface (SITP[1:0] = 0,1), external clock mode (SPICLKSEL[1:0] = 0) | | TBD | TBD | TBD | |
| | | 2.3V < VDD < 3.63V, SPI interface (SITP[1:0] = 0,1), internal clock mode (SPICLKSEL[1:0] ≠ 0) | | TBD | TBD | TBD | |
| | | 2.3V < VDD < 3.63V, SPI interface (SITP[1:0] = 0,1), internal clock mode (SPICLKSEL[1:0] ≠ 0) | | TBD | TBD | TBD | |
| f_{CKOUT} | Output clock frequency | 2.3V < VDD < 3.63V | | TBD | TBD | TBD | |
| Duty _{CKOUT} | Output clock duty cycle | 2.3V < VDD < 3.63V | TBD | TBD | TBD | TBD | % |
| | | | TBD | TBD | TBD | TBD | |
| $t_{wh}(CKIN)$ $t_{wl}(CKIN)$ | Input clock high/low pulse width | 2.3V < VDD < 3.63V, SPI interface (SITP[1:0] = 0,1), external clock mode (SPICLKSEL[1:0] = 0) | | TBD | TBD | TBD | ns |
| t_{su} | Input data setup time | 2.3V < VDD < 3.63V, SPI interface (SITP[1:0] = 0,1), external clock mode (SPICLKSEL[1:0] = 0) | | TBD | TBD | TBD | |
| t_h | Input data hold time | 2.3V < VDD < 3.63V, SPI interface (SITP[1:0] = 0,1), external clock mode (SPICLKSEL[1:0] = 0) | | TBD | TBD | TBD | |
| $T_{Manchester}$ | Manchester data period (self-recovery clock period) | 2.3V < VDD < 3.63V, Manchester interface (SITP[1:0] = 2,3), internal clock mode (SPICLKSEL[1:0] ≠ 0) | | TBD | TBD | TBD | |

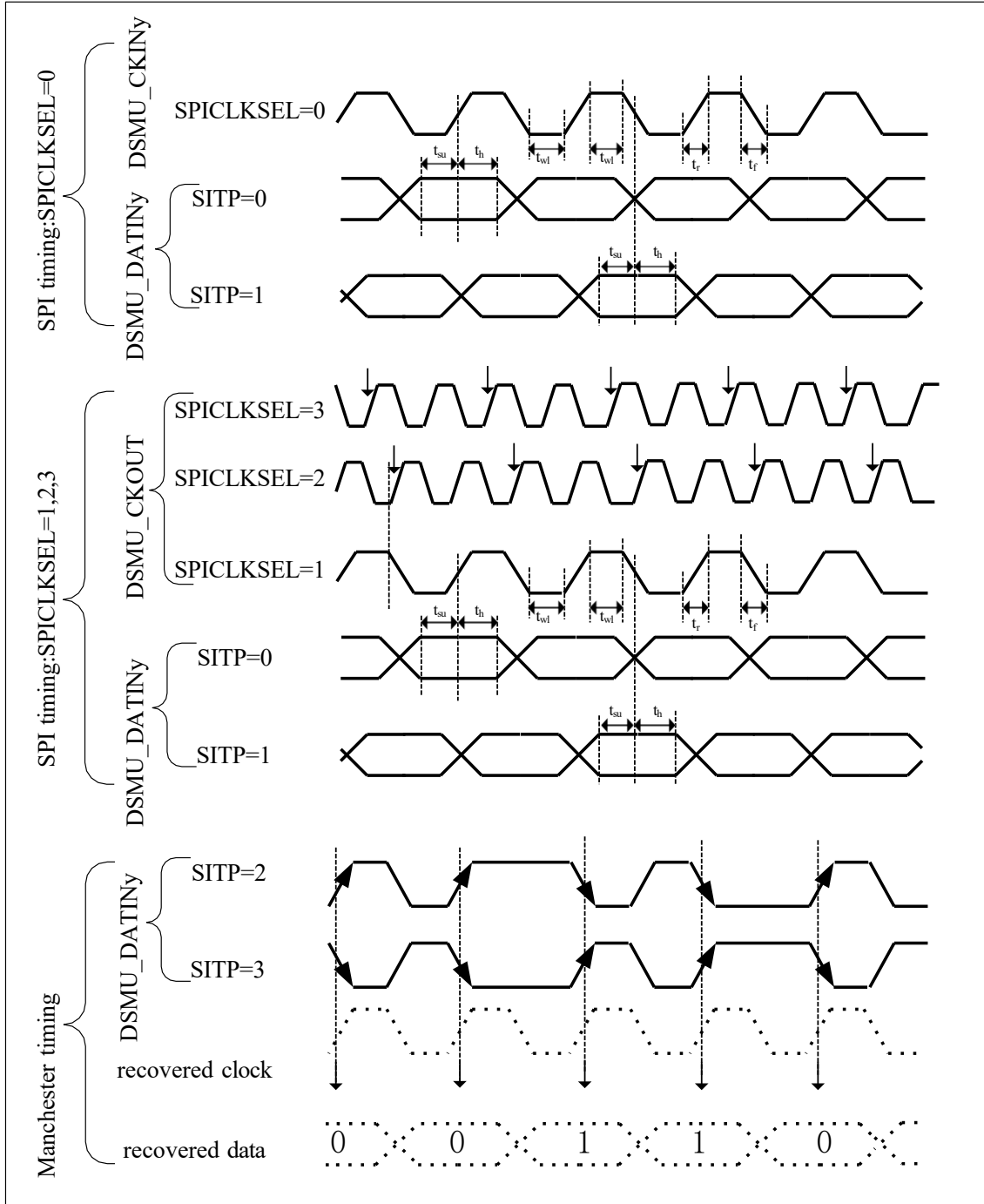
Figure 4-53 DSMU Channel Transceiver Timing Diagram

4.3.30 12-bit Analog-to-Digital Converter (ADC) Electrical Characteristics

Unless otherwise specified, the parameters in **Table 4-78** are measured under the environmental conditions (ambient temperature 25 °C), f_{HCLK} frequency, and V_{DDA} supply voltage specified in **Table 4-4**.

Note: It is recommended to perform a calibration each time after power-up.

Table 4-78 ADC Characteristics

| Symbol | Parameter | Conditions | Min | Typ | Max | Unit |
|----------------------------------|---|---------------------------|--|-----|-------------------|--------------------|
| V _{DDA} | Supply voltage | - | 2.3 | - | 3.6 | V |
| V _{REF+} | Positive reference voltage | - | 2.3 | - | V _{DDA} | V |
| f _{ADC} | ADCclock frequency | - | - | - | 20 | MHz |
| f _s | Sampling rate (1) | - | - | - | 5 | Msp/s |
| V _{AIN} | Conversion voltage range (2) | - | 0(V _{SSA} or V _{REF-} tied to ground) | - | V _{REF+} | V |
| R _{ADC} | Sample switch resistance | 2.4~3.3V | - | 250 | | ohm |
| | | 2.3~2.4V | - | 350 | | |
| C _{ADC} | Internal sample and hold capacitor | - | - | 1.5 | - | pF |
| SNDR | Singal noise distortion ration | - | - | TBD | - | dBFS |
| T _{cal} | Calibration time | - | 74 | | | 1/f _{ADC} |
| t _s | Sampling time | f _{ADC} = 20 MHz | 0.05 | - | 7 | us |
| T _s | | | 1 | - | - | 1/f _{ADC} |
| t _{STAB} | Power-up time | - | 0 | 0 | 20 | μs |
| t _{CON_V} (2) | Total conversion time (including sampling time) | - | 4~400 (sampling t _s + successive approximation 3) | | | 1/f _{ADC} |

Notes:

1. Guaranteed by design, not tested in production.
2. Depending on the package, V_{REF+} may be internally connected to V_{DDA}, and V_{REF-} may be internally connected to V_{SSA}.
3. The relationship between maximum input impedance R_{in} and sampling time is detailed in **Table 4-67**.

Table 4-79 ADC Sampling Time (1)(2)

| Resolution | R _{in} (kΩ) | Minimum Sampling Time (ns) |
|------------|----------------------|----------------------------|
| 12-bit | 0 | 50 |
| | 0.45 | 100 |
| | 0.7 | 150 |
| | 0.95 | 200 |

| | | |
|--------|------|------|
| | 1.95 | 400 |
| | 2.95 | 600 |
| | 3.95 | 800 |
| | 4.95 | 1000 |
| | 9.95 | 2000 |
| 10-bit | TBD | TBD |
| | TBD | TBD |
| | TBD | TBD |
| | TBD | TBD |
| | TBD | TBD |
| | TBD | TBD |
| | TBD | TBD |
| | TBD | TBD |

Notes:

1. *Guaranteed by design, not tested in production.*
2. *Test conditions: $V_{dda} = 2.4V$ to $3.6V$, $V_{ddd} = 0.9V$, $T_{junction} = 125^{\circ}C$, $f_{clk} = 20$ MHz.*

Table 4-80 ADC Accuracy – Limited Test Conditions⁽¹⁾⁽²⁾

| Symbol | Parameter | Test Conditions | Typ | Max ⁽³⁾ | Unit |
|-------------------|----------------------------------|--|-----|--------------------|------|
| ET ⁽⁴⁾ | Total Error | fHCLK = 200 MHz, fADC = 20 MHz, sample rate = 3Msps, VDDA = 3.3V, TA = 25°C. Measurement is performed after ADC calibration. VREF+ = 2.5V | TBD | TBD | LSB |
| EO ⁽⁴⁾ | Offset Error | | TBD | TBD | |
| ED | Differential Non-Linearity Error | | TBD | TBD | |
| EL | Integral Non-Linearity Error | | TBD | TBD | |

Notes:

1. *ADC DC accuracy values are measured after internal calibration.*
2. *Relationship between ADC accuracy and reverse injection current: avoid injecting reverse currents on any standard analog input pins, as it significantly degrades the conversion accuracy of other analog inputs. It is recommended to add a Schottky diode (between the pin and ground) on any analog input pins that may have reverse injection currents.*
3. *Forward injection currents within the IINJ(PIN) range specified in Section 4.2 will not affect ADC accuracy.*
4. *Guaranteed by overall evaluation, not tested in production.*

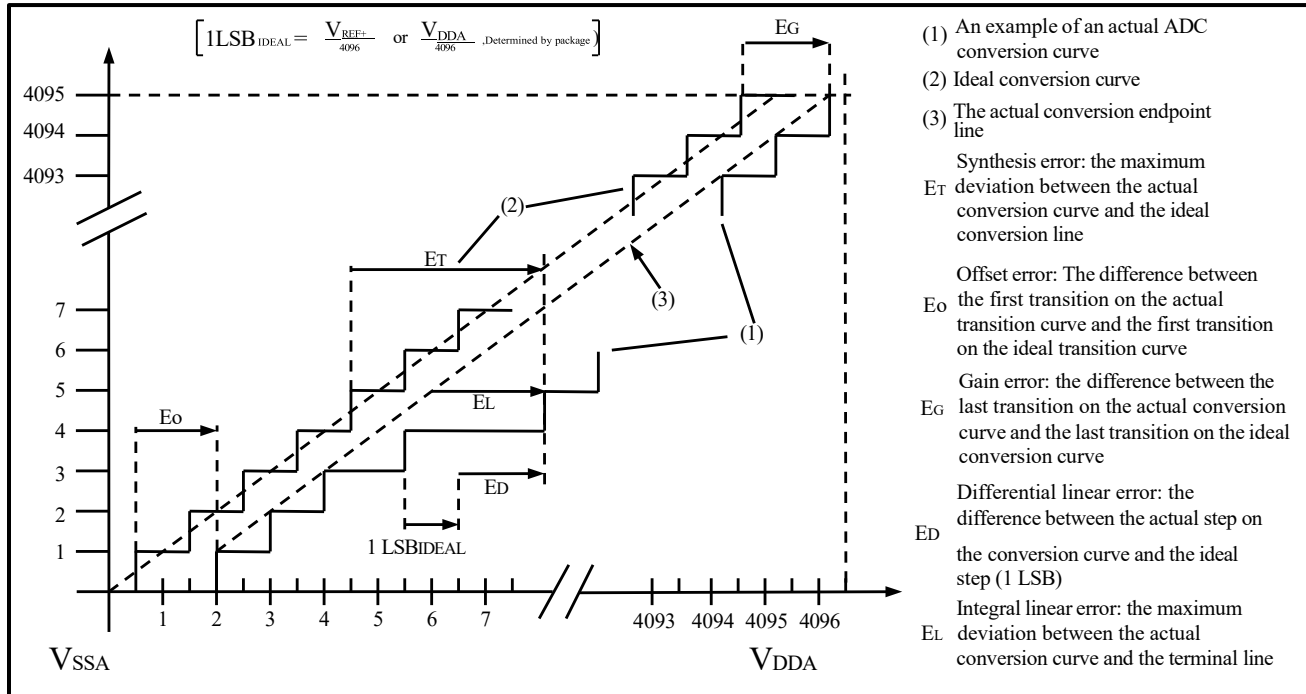
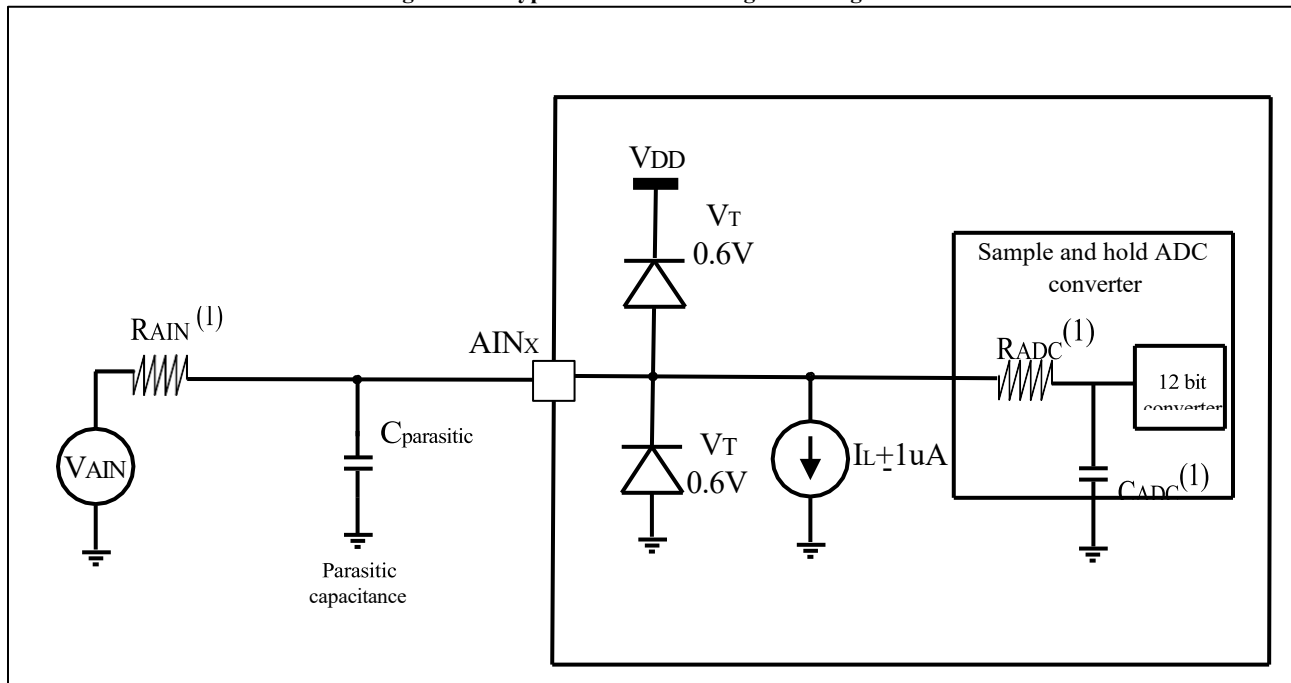
Figure 4-54 ADC Accuracy Characteristics

Figure 4-55 Typical Connection Diagram Using ADC

Notes:

- For values of R_{AIN} , R_{ADC} , and C_{ADC} , refer to Table 4-66.
- $C_{parasitic}$ refers to the parasitic capacitance (approximately 7pF) on the PCB and solder pads (related to soldering and PCB layout quality). A larger $C_{parasitic}$ value will reduce conversion accuracy. The solution is to lower f_{ADC} .

4.3.31 12-bit Digital-to-Analog Converter (DAC) Electrical Parameters

Unless otherwise specified, the parameters in **Table 4-81** are measured under environmental conditions specified in **Table 4-4** (ambient temperature 25°C), **fHCLK** frequency, and **VDDA** supply voltage.

Table 4-81 DAC 1MSPS Characteristics

| Symbol | Parameter | Conditions | Min | Typ | Max | Unit |
|-----------------------|--|---|------------------|-----|-------------------------|------|
| V _{DDA} | Analog supply voltage | DAC output buffer off, output internal only | 2.3 | - | 3.6 | V |
| V _{REF+} | Positive reference voltage | DAC output buffer off, output internal only | 2.3 | - | V _{DDA} | |
| V _{REF-} | Negative reference voltage | - | V _{SSA} | | | |
| R _L | Load resistance when buffer is on | DAC output Connected to V _{SSA} | 5 | - | - | kΩ |
| | | Buffer on Connected to V _{DDA} | 25 | - | - | |
| R _o | Output impedance | DAC output buffer off | - | 15 | - | kΩ |
| C _L | Load capacitance | - | - | - | 50 | pF |
| DAC_OUT Max | DAC_OUT output voltage | Output buffer on | 0.2 | - | V _{REF+} - 0.2 | V |
| | | Output buffr off | TBD | TBD | TBD | - |
| I _{DD} | DAC DC consumption in idle (standby mode) (V _{DDD} +V _{DDA} +V _{REF+}) | - | TBD | TBD | TBD | μA |
| | | - | TBD | TBD | TBD | μA |
| t _{SETTLING} | Settling time (full range: 12-bit input code from min to max, DAC_OUT reaches final value ±1 LSB) | DAC buffer on CL ≤ 50 pF, RL ≥ 5 kΩ | - | 3 | 4.1 | μs |
| | | DAC buffer off | - | 2.1 | 2.6 | |
| t _{WAKEUP} | Wake-up time from shutdown (DAC enabled to DAC_OUT reaches final value ±1 LSB) | DACbuffer on, CL ≤ 50 pF, RL ≥ 5 kΩ | - | 6.5 | 10 | μs |
| | | DACbuffer on, CL ≤ 10 pF | - | 2.1 | 5 | |
| PSRR | Power Supply Rejection Ratio (relative to VDD33A) (static DC measurement) | DACbuffer on, CL ≤ 50 pF, RL ≥ 5 kΩ | TBD | TBD | TBD | dB |
| TW _{to_W} | Minimum time between two consecutive writes to DACx_DATO register to ensure correct DAC_OUT(1 LSB). DACxy_CTRL.EXOUT = 1, DACxy_CTRL.BxEN = 1 DACxy_CTRL.EXOUT = 1, DACxy_CTRL.BxEN = 0 或 | CL ≤ 50 pF, RL ≥ 5 kΩ | TBD | - | - | μs |
| | | CL ≤ 10 pF | TBD | - | - | |

| | | | | | | | |
|------------|--|---|-----------------------------|-----|-----|------|-----|
| | DACxy_CTRL.INOUT = 1, DACxy_CTRL.BxEN = 0 | | | | | | |
| Voffset | Middle code offset for 1 trim code step | VREF+ = 3.6V | | - | - | 1500 | μV |
| IDDA(DAC) | DAC consumption from VDDA | Output buffer on | No load, input mid 0x800 | TBD | TBD | TBD | μA |
| | | | No load, input Max 0xF1C | TBD | TBD | TBD | |
| | | Output buufer off | No load, input mod 0x800 | TBD | TBD | TBD | |
| IDDV(DAC) | DAC consumption from VREF+ | Output buffer on | No load, input mid 0x800 | TBD | TBD | TBD | μA |
| | | | No load | TBD | TBD | TBD | |
| | | Output buffer off | No load, input mid 0x800 | TBD | TBD | TBD | |
| DNL | Differential Non-Linearity) | - | | - | TBD | TBD | TBD |
| INL | Integral Non-Linearity | - | | - | TBD | TBD | TBD |
| Offset | Offset error (measured at code 0x800) | Output buffer on, CL ≤ 50 pF, RL ≥ 5 kΩ | VREF+ = 3.6V | TBD | TBD | TBD | LSB |
| | | | VREF+ = 1.8V | TBD | TBD | TBD | |
| | | Output buffer off, CL ≤ 50 pF, no RL | - | TBD | TBD | | |
| Gain error | Gain error | - | | - | TBD | TBD | TBD |

Note: Guaranteed by characterization, not tested in production.

4.3.32 Comparator (COMP) Characteristics

Unless otherwise specified, the parameters in **Table 4-82** are measured under environmental conditions specified in **Table 4-4** (ambient temperature 25°C), **fHCLK** frequency, and **VDDA** supply voltage.

Table 4-82 Comparator Characteristics

| Symbol | Parameter | Conditions | Min | Typ | Max | Unit |
|------------------|--|------------------------------|-----|-----|------------------|------|
| V _{DDA} | Analog supply voltage | - | 2.3 | - | 3.6 | V |
| V _{IN} | Input voltage range | - | 0 | - | V _{DDA} | |
| V _{REF} | 6bit DAC offset voltage | DAC mid output, VREFP = 3.3V | - | ±5 | ±12 | mV |
| I _{REF} | 6bit DAC static consumption from VREFP | DAC mid output, VREFP = 3.3V | - | TBD | TBD | uA |

| | | | | | | |
|---------------------|---|---|---|-----|-----|----|
| | | DAC max output, VREFP = 3.3V | - | | TBD | uA |
| T _{START} | Comparator start-up settling time | VDDA ≥ 2.7 | - | - | 5 | us |
| | | VDDA < 2.7V | - | - | 7 | |
| t _d | Propagation delay for 200 mV step with 100 mV overdrive | VDDA ≥ 2.7 | - | 30 | - | ns |
| | | VDDA < 2.7V | - | 20 | - | |
| V _{OFFSET} | Comparator input offset error | Full common mode range | - | - | ±10 | mV |
| V _{hys} | Comparator hysteresis | No hysteresis | - | 0 | - | mV |
| | | Low hysteresis | - | 20 | - | |
| | | Medium hysteresis | - | 30 | - | |
| | | High hysteresis | - | 50 | - | |
| I _{DDA} | Comparator consumption from VDDA | Static | - | 140 | - | μA |
| | | With 50 kHz ±100 mV overdrive square signal | - | 150 | - | |

Note: Guaranteed by design, not tested in production.

4.3.33 Voltage Reference Buffer (VREFBUF) Characteristics

Unless otherwise specified, the parameters in **Table 4-83** are measured under environmental conditions specified in **Table 4-4** (ambient temperature 25°C), **f_{HCLK}** frequency, and **VDDA** supply voltage.

Table 4-83 Voltage Reference Buffer Characteristics ⁽¹⁾

| Symbol | Parameter | Conditions | Min | Typ | Max | Unit |
|---------------------------|-------------------------------|---------------------------|-------|-------|-------|------|
| V _{DDA} | Analog supply voltage | - | 2.3 | - | 3.6 | V |
| V _{REFBUF_OUT} | Reference voltage output | VS= 00 & VDDA ≥ 2.8V | 2.494 | 2.498 | 2.51 | |
| | | VS= 01 & VDDA ≥ 2.4V | 2.022 | 2.024 | 2.034 | |
| | | VS=10 & VDDA ≥ 2.3V | 1.801 | 1.802 | 1.811 | |
| | | VS=11 & VDDA ≥ 2.3V | 1.496 | 1.497 | 1.505 | |
| TRIM | Trim step resolution | - | - | ±0.05 | ±0.1 | % |
| CL | Load capacitance | - | 0.5 | 1 | 2 | μF |
| R _{ESR} | Equivalent Series Resistance | - | 0 | 0 | 2 | Ω |
| PSRR | Power Supply Rejection Ratio | DC | 37.54 | 49.72 | TBD | dB |
| | | 100KHz | 12.1 | 70.36 | TBD | |
| t _{START} | Start-up time | CL =1 μF | - | 366.1 | 1080 | μs |
| I _{DDA(VREFBUF)} | VREFBUF consumption from VDDA | I _{load} ≤ 10 mA | - | 48 | TBD | μA |

| | | | | | | |
|--------------|--|----------------|------|-------|-----|----|
| I_{INRUSH} | Max $I_{DDA}(V_{REFBUF})$ at startup phase | $I_{load} = 0$ | 7.42 | 18.88 | TBD | mA |
|--------------|--|----------------|------|-------|-----|----|

Note: Guaranteed by design, not tested in production.

4.3.34 Temperature Sensor (TS) Characteristics

Unless otherwise specified, the parameters in **Table 4-84** are measured under environmental conditions specified in **Table 4-4** (ambient temperature 25°C), f_{HCLK} frequency, and V_{DDA} supply voltage.

Table 4-84 Temperature Sensor Characteristics

| Symbol | Parameter | Min | Typ | Max | Unit |
|--------------------------|---|-----|---------|------|-------|
| $T_L^{(1)}$ | Linearity V_{SENSE} with respect to temperature | - | ± 3 | TBD | °C |
| Avg_Slope ⁽¹⁾ | Average slope | TBD | -3.4 | TBD | mV/°C |
| $V_{25}^{(1)}$ | Voltage at 25°C | - | 1.37 | - | V |
| $t_{START}^{(1)}$ | Start-up time | 4 | - | 10 | μs |
| $T_{S_temp}^{(2)(3)}$ | ADC sampling time when reading temperature | 8.2 | - | 17.1 | μs |

Notes:

1. *Guaranteed by characterization, not tested in production.*
2. *Guaranteed by design, not tested in production.*
3. *The minimum sampling time can be determined by multiple loop cycles in the application.*

5 Package Size

5.1 UFBGA176+25 Package Size

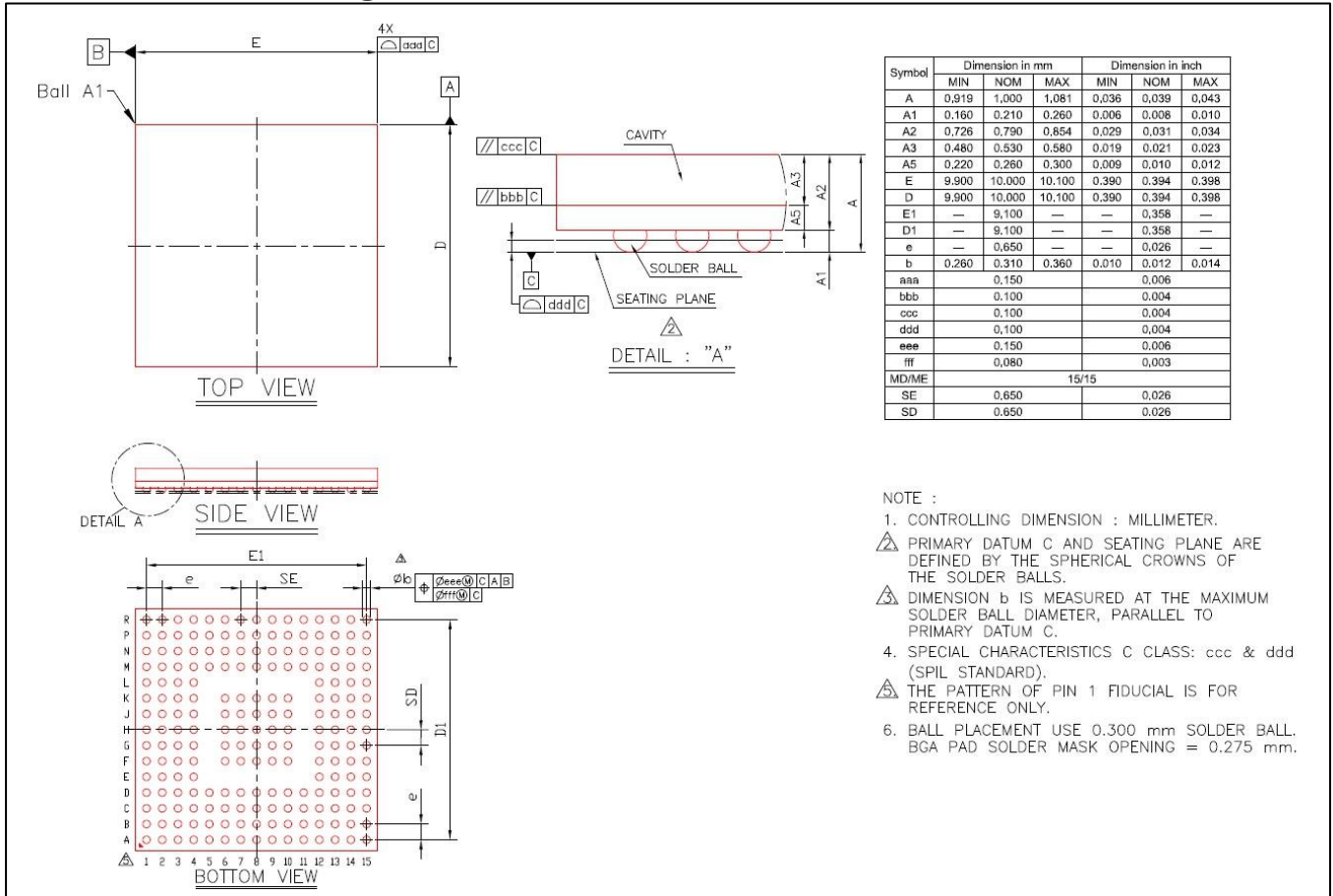

5.2 Silkscreen Description

Figure 5-1 Silkscreen Diagram

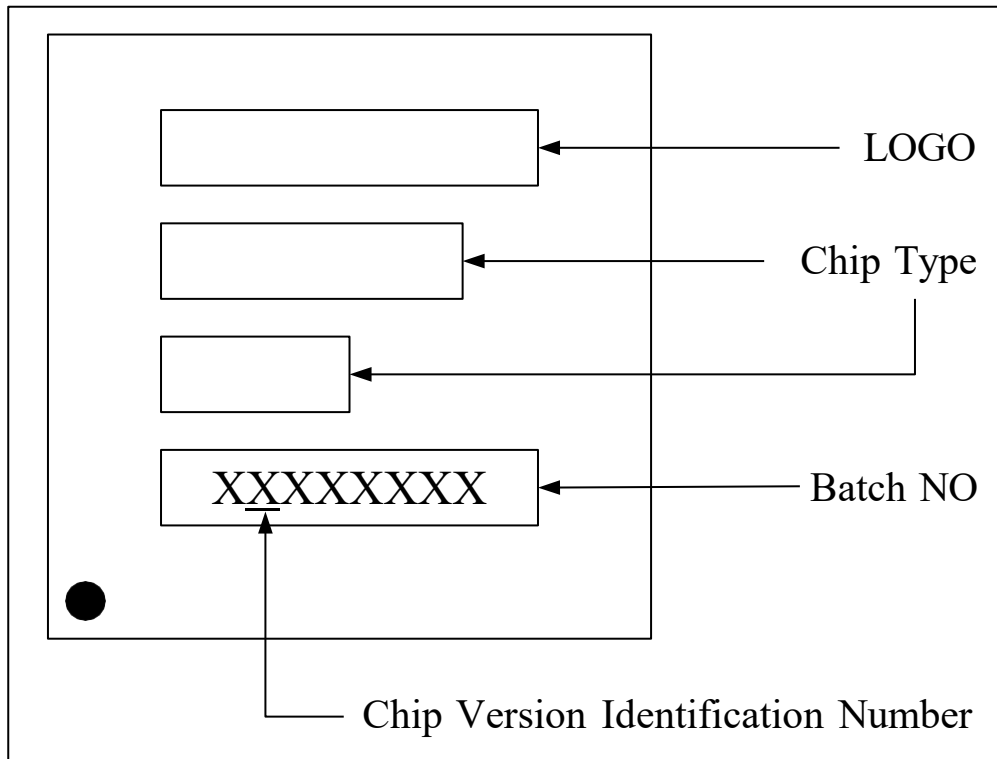

6 Version History

| Version | Date | Changes |
|---------|------------|---------------|
| V1.0.0 | 2025.05.13 | First release |

7 Disclaimer

This document is the exclusive property of NSING TECHNOLOGIES PTE. LTD. (Hereinafter referred to as NSING SG). This document, and the product of NSING SG described herein (Hereinafter referred to as the Product) are owned by NSING SG under the laws and treaties of Republic of Singapore and other applicable jurisdictions worldwide. The intellectual properties of the product belong to NSING TECHNOLOGIES INC. (Hereinafter referred to as NSING) and NSING TECHNOLOGIES INC. does not grant any third party any license under its patents, copyrights, trademarks, or other intellectual property rights. Names and brands of third party may be mentioned or referred thereto (if any) for identification purposes only. NSING SG reserves the right to make changes, corrections, enhancements, modifications, and improvements to this document at any time without notice. Please contact NSING SG and obtain the latest version of this document before placing orders. Although NSING has attempted to provide accurate and reliable information, NSING assumes no responsibility for the accuracy and reliability of this document. It is the responsibility of the user of this document to properly design, program, and test the functionality and safety of any application made of this information and any resulting product. In no event shall NSING be liable for any direct, indirect, incidental, special, exemplary, or consequential damages arising in any way out of the use of this document or the Product. NSING Products are neither intended nor warranted for usage in systems or equipment, any malfunction or failure of which may cause loss of human life, bodily injury or severe property damage. Such applications are deemed, Insecure Usage'. Insecure usage includes, but is not limited to: equipment for surgical implementation, atomic energy control instruments, airplane or spaceship instruments, all types of safety devices, and other applications intended to supporter sustain life. All Insecure Usage shall be made at user's risk. User shall indemnify NSING and hold NSING harmless from and against all claims, costs, damages, and other liabilities, arising from or related to any customer's Insecure Usage Any express or implied warranty with regard to this document or the Product, including, but not limited to. The warranties of merchantability, fitness for a particular purpose and non-infringement are disclaimed to the fullest extent permitted by law. Unless otherwise explicitly permitted by NSING, anyone may not use, duplicate, modify, transcribe or otherwise distribute this document for any purposes, in whole or in part.