

## N32G435x8/xB

## Datasheet

N32G435 series adopts a 32-bit ARM Cortex-M4F core, with a maximum operating frequency of 108MHz, supporting floating-point unit and DSP instructions. It integrates up to 128KB embedded flash, 32KB SRAM, high-performance analog interface such as 1x12bit 5Msps ADC, 2x independent rail-to-rail operational amplifiers, 2x high-speed comparators, 1x 1Msps 12bit DAC, multiple communication bus interfaces (U(S)ART, I2C, SPI, USB, CAN, etc). It also features a built-in hardware acceleration engine for cryptographic algorithms.

### Key Features

- **CPU Core**
  - 32-bit ARM Cortex-M4F + FPU, single-cycle hardware multiplication and division instruction, support DSP instruction and MPU
  - Built-in 2KB instruction Cache supports Flash acceleration unit for zero-wait program execution
  - Frequency up to 108MHz, 135DMIPS
- **Memories**
  - Up to 128KByte of embedded Flash memory with ECC
    - Support encryption multi-user partition and data protection
    - 100,000 erase/write cycles and 10-years data retention
  - Up to 32KByte of SRAM with hardware parity checking, including 24Kbyte SRAM1(In STOP2 mode, SRAM1 can be configured to data retention) and 8 Kbyte SRAM2(In STANDBY and STOP2 mode, SRAM2 can be configured to data retention)
- **Low Power Management**
  - STANDBY mode: 2.5uA, all backup registers retained, all IOs retained, optional RTC Run, 8KByte SRAM2 can be configured to retention, supports fast wake up.
  - STOP2 mode: 6uA, RTC Run, 8KByte SRAM2 and 24Kbyte SRAM1 can be configured to retention, CPU registers retained, IOs retained, supports fast wake up
  - RUN mode: 90uA/MHz@108MHz
  - LPRUN mode: PLL off, MSI as the system master clock, MR off, LPR on, USB/CAN/CRYE power off, other peripherals are optional.
  - SLEEP mode: only CPU is stopped, all peripherals are optional.
  - LP-SLEEP mode: CPU is stopped, the PLL is off, USB/CAN/CRYE module are disabled, all IOs remained, other peripherals are optional.
- **High Performance Analog Interfaces**
  - 1x 12bit ADCs with 5Msps
  - Multiple precision configuration
    - Sampling rate up to 9Msps in 6-bit mode
    - Up to 16 external single-ended input channels, support differential mode
    - 2x rail-to-rail operational amplifiers with built-in maximum 32x programmable gain amplifier(PGA)

- 2x high-speed analog comparators, built-in 64-level adjustable comparison reference, COMP1 support operating in STOP2 mode
- 1x 12bit DAC, sampling rate 1Msps
- Internal 2.048V independent reference voltage source
- Internal integrated low-voltage detection unit
- **Clock**
  - HSE: 4MHz~32MHz high-speed external crystal oscillator
  - LSE: 32.768KHz low-speed external crystal oscillator
  - HSI: High-speed internal RC 16MHz
  - MSI: Multi-speed internal RC 100K~4MHz
  - LSI: Low-speed internal RC 40KHz
  - Built-in high speed PLL
  - MCO: Supports 1-channel clock output, which can be configured as low-speed or high-speed clock output
- **Reset**
  - Supports power-on/brown-out/external pin reset
  - Supports watchdog reset
- **GPIOs**
  - Up to 52 GPIOs
  - Support multiplexed functions.
  - Maximum toggle speed of 50 MHz
- **Communication Interfaces**
  - 5x U(S)ART interfaces,
    - 3x USART interfaces (support ISO7816, IrDA, LIN)
    - 2x UART interfaces
  - 1x LPUART, support wakeup MCU in STOP2 mode.
  - 2x SPI interfaces with speed up to 27 Mbps, support I2S
  - 2x I2C interfaces (Master/Slave) with speed up to 1 MHz where slave mode support dual address response
  - 1x USB2.0 FS Device interface
  - 1x CAN 2.0A/B bus interface
- **DMA Controllers**
  - 1x DMA controller
  - Each controller support 8 channels
  - Channel source address and destination address can be configured arbitrarily.
- **RTC real-time clock**
  - Supports leap-year calendar, alarm event, periodic wake up
  - Supports internal and external clock calibration.
- **Timers**
  - 2x 16-bit advanced timers with maximum control precision of 9.25ns
    - Support input capture, complementary output, quadrature encoder input etc.

- Each has 4 independent channels, 3 of which support 6-channel complementary PWM output.
- 5x 16-bit general purpose timers
  - Support input capture/output comparison/PWM output.
  - Each timer has 4 independent channels
- 2x 16-bit basic timers
- 1x 16-bit low-power timer, support double pulse counting function, can work in STOP2 mode.
- 1x 24-bit SysTick timer.
- 1x 7-bit Window Watchdog (WWDG)
- 1x 12-bit Independent Watchdog (IWDG)
- **Programming Methods**
  - Support SWD/JTAG debugging interface.
  - Support UART and USB Bootloader
- **Security Features**
  - Built-in hardware acceleration engine for cryptographic algorithm.
  - Supports AES, DES, TDES, SHA1/224/256 and SM7 algorithms.
  - Flash encryption, multi-user partition management unit (MMU)
  - True random number generator (TRNG)
  - CRC16/32 operation
  - Supports write protection (WRP), multiple read protection (RDP) levels (L0/L1/L2)
  - Supports secure boot, program encryption download, secure firmware update.
  - Supports external clock failure detection, anti-tamper detection.
- **96-bit UID and 128-bit UCID**
- **Operating Conditions**
  - Operating voltage range: 1.8V~3.6V
  - Operating temperature range: -40°C ~ 105°C
  - ESD: ±4KV (HBM model), ±1KV (CDM model)
- **Packages**
  - QFN28(4mm×4mm)
  - LQFP32(7mm×7mm)
  - LQFP48(7mm×7mm)
  - LQFP64(10mm×10mm)
  - LQFP64(7mm×7mm)

- **Ordering Information**

Reference	Part Number
N32G435x8	N32G435G8Q7, N32G435K8L7, N32G435C8L7, N32G4352R8L7
N32G435xB	N32G435KBL7, N32G435CBL7, N32G435RBL7 <sup>(1)</sup> N32G435GBQ7, N32G435RBL7-1 <sup>(2)</sup>

*Note:*

<sup>(1)</sup> Package is LQFP64 (10mm×10mm)

<sup>(2)</sup> Package is LQFP64 (7mm×7mm)

## Contents

<b>1</b>	<b>INTRODUCTION.....</b>	<b>10</b>
1.1	NAMING CONVENTION.....	11
1.2	PRODUCT CONFIGURATIONS.....	12
<b>2</b>	<b>FUNCTIONAL OVERVIEW.....</b>	<b>13</b>
2.1	PROCESSOR CORE.....	13
2.2	MEMORIES.....	13
2.2.1	Embedded FLASH Memory.....	14
2.2.2	Embedded SRAM.....	14
2.2.3	Nested Vector Interrupt Controller (NVIC).....	14
2.3	EXTENDED INTERRUPT/EVENT CONTROLLER (EXTI).....	14
2.4	CLOCK SYSTEM.....	14
2.5	BOOT MODES.....	16
2.6	POWER SUPPLY SCHEME.....	16
2.7	RESET.....	16
2.8	PROGRAMMABLE VOLTAGE DETECTOR.....	16
2.9	VOLTAGE REGULATOR.....	16
2.10	LOW POWER MODE.....	16
2.11	DIRECT MEMORY ACCESS (DMA).....	17
2.12	REAL TIME CLOCK (RTC).....	17
2.13	TIMERS AND WATCHDOGS.....	18
2.13.1	Low Power Timer (LPTIM).....	18
2.13.2	Basic Timer (TIM6 and TIM7).....	18
2.13.3	General-Purpose Timer (TIMx).....	19
2.13.4	Advanced Control Timer (TIM1 and TIM8).....	19
2.13.5	SysTick Timer (Systick).....	20
2.13.6	Watchdog (WDG).....	20
2.14	I <sup>2</sup> C BUS INTERFACE.....	21
2.15	UNIVERSAL SYNCHRONOUS/ASYNCHRONOUS TRANSCEIVER (USART).....	22
2.16	LOW POWER ASYNCHRONOUS TRANSCEIVER (LPUART).....	23
2.17	SERIAL PERIPHERAL INTERFACE (SPI).....	24
2.18	SERIAL AUDIO INTERFACE (I <sup>2</sup> S).....	25
2.19	CONTROLLER AREA NETWORK (CAN).....	26
2.20	UNIVERSAL SERIAL BUS (USB).....	26
2.21	GENERAL-PURPOSE INPUT/OUTPUT INTERFACE (GPIO).....	27
2.22	ANALOG/DIGITAL CONVERTER (ADC).....	27
2.23	OPERATIONAL AMPLIFIER (OPAMP).....	28
2.24	ANALOG COMPARATOR (COMP).....	29
2.25	DIGITAL/ANALOG CONVERTER (DAC).....	29
2.26	TEMPERATURE SENSOR (TS).....	30
2.27	CYCLIC REDUNDANCY CHECK CALCULATION UNIT (CRC).....	30
2.28	CRYPTOGRAPHIC ENGINE (CRYE).....	30
2.29	UNIQUE DEVICE SERIAL NUMBER (UID).....	30
2.30	SERIAL SINGLE-WIRE JTAG DEBUG PORT (SWJ-DP).....	31
<b>3</b>	<b>PINOUTS AND PIN DESCRIPTION.....</b>	<b>32</b>
3.1	PINOUTS.....	32
3.1.1	QFN28.....	32
3.1.2	LQFP32.....	33
3.1.3	LQFP48.....	34
3.1.4	LQFP64.....	35
3.2	PIN DESCRIPTION.....	36
<b>4</b>	<b>ELECTRICAL CHARACTERISTICS.....</b>	<b>42</b>
4.1	PARAMETER CONDITIONS.....	42
4.1.1	Minimum and Maximum Values.....	42

4.1.2	Typical Values .....	42
4.1.3	Typical Curves .....	42
4.1.4	Loading Capacitors .....	42
4.1.5	Pin Input Voltage .....	42
4.1.6	Power Supply Scheme .....	43
4.1.7	Current Consumption Measurement .....	43
4.2	ABSOLUTE MAXIMUM RATING .....	44
4.3	OPERATING CONDITIONS .....	45
4.3.1	General Operating Conditions .....	45
4.3.2	Operating Conditions at Power-on and Power-off.....	45
4.3.3	Embedded Reset and Power Control Module Characteristics.....	45
4.3.4	Internal Reference Voltage .....	46
4.3.5	Power Supply Current Characteristics .....	46
4.3.6	External Clock Source Characteristics .....	49
4.3.7	Internal Clock Source Characteristics.....	53
4.3.8	Time to wake up from low power mode .....	54
4.3.9	PLL Characteristics.....	55
4.3.10	FLASH Memory Characteristics .....	55
4.3.11	Absolute Maximum (Electrical Sensitivity) .....	56
4.3.12	I/O Port Characteristics .....	57
4.3.13	NRST Pin Characteristics.....	60
4.3.14	Timer and Watchdog Characteristics.....	61
4.3.15	I <sup>2</sup> C Interface Characteristics .....	62
4.3.16	SPI/I <sup>2</sup> S Interface Characteristics.....	64
4.3.17	USB Characteristics.....	68
4.3.18	Controller Area Network (CAN) Interface Characteristics .....	69
4.3.19	Electrical Parameters of 12 bit Analog-to-Digital Converter (ADC) .....	69
4.3.20	Internal Reference Source (V <sub>REFBUFF</sub> ) Electrical Parameters .....	73
4.3.21	12-bit DAC Electrical Parameters .....	73
4.3.22	Operational Amplifier (OPAMP) Electrical Parameters .....	74
4.3.23	Comparator 2(COMP2) Electrical Parameters .....	75
4.3.24	Comparator 1(COMP1) Electrical Parameters .....	76
4.3.25	Temperature Sensor (TS) Characteristics .....	77
<b>5</b>	<b>PACKAGES .....</b>	<b>78</b>
5.1	QFN28 (4MM×4MM).....	78
5.2	LQFP32 (7MM×7MM) .....	79
5.3	LQFP48 (7MM×7MM) .....	80
5.4	LQFP64 (10MM×10MM).....	81
5.5	LQFP64 (7MM×7MM).....	82
5.6	MARKING INFORMATION .....	83
<b>6</b>	<b>VERSION HISTORY .....</b>	<b>84</b>
<b>7</b>	<b>DISCLAIMER.....</b>	<b>87</b>

## List of Tables

Table 1-1 N32G435 Series Product Configuration.....	12
Table 2-1 Comparison Of Timer Functions.....	18
Table 3-1 Pin Description.....	36
Table 4-1 Voltage Characteristics .....	44
Table 4-2 Current Characteristics.....	44
Table 4-3 Temperature Characteristics .....	44
Table 4-4 General Operating Conditions.....	45
Table 4-5 Operating Conditions At Power-On And Power-Off.....	45
Table 4-6 Features Of Embedded Reset And Power Control Modules.....	45
Table 4-7 Internal Reference Voltage .....	46
Table 4-8 Maximum Current Consumption In Operating Mode Where The Data Processing Code Is Run From Internal Flash .....	47
Table 4-9 Maximum Current Consumption In Sleep Mode, Code Running In Internal Flash Running.....	47
Table 4-10 Typical Current Consumption In Operating Mode, Where Data Processing Code Is Run From Internal Flash .....	48
Table 4-11 Typical Current Consumption In Sleep Mode, Data Processing Code Is Run From Internal Flash.....	48
Table 4-12 Typical And Maximum Current Consumption In Shutdown And Standby Mode .....	49
Table 4-13 High-Speed External User Clock Features(Bypass Mode).....	49
Table 4-14 Features Of A Low-Speed External User Clock(Bypass Mode).....	50
Table 4-15 HSE 4~32MHz Oscillator Characteristics <sup>(1) (2)</sup> .....	51
Table 4-16 LSE Oscillator Characteristics ( $f_{LSE} = 32.768\text{kHz}$ ) <sup>(1) (2) (4) (5)</sup> .....	52
Table 4-17 MSI Oscillator Characteristics <sup>(1)</sup> .....	53
Table 4-18 HSI Oscillator Characteristics <sup>(1) (2)</sup> .....	53
Table 4-19 LSI Oscillator Characteristics <sup>(1)</sup> .....	54
Table 4-20 Wake Time In Low Power Mode.....	55
Table 4-21 PLL Features.....	55
Table 4-22 Flash Memory Characteristics.....	55
Table 4-23 Flash Endurance And Data Retention Life.....	56
Table 4-24 Absolute Maximum ESD Value.....	56
Table 4-25 Electrical Sensitivity .....	57
Table 4-26 I/O Static Characteristics.....	57
Table 4-27 IO Output Drive Capability Characteristics .....	58
Table 4-28 Output Voltage Characteristics .....	58
Table 4-29 Input/Output AC Characteristics <sup>(1)</sup> .....	59
Table 4-30 NRST Pin Characteristics .....	60
Table 4-31 TIM1/8 Characteristics .....	61
Table 4-32 TIM2/3/4/5/6/7/9 Characteristics .....	61
Table 4-33 LPTIMER Characteristics.....	62
Table 4-34 IWDG Counting Maximum And Minimum Reset Time ( $LSI = 40\text{kHz}$ ).....	62
Table 4-35 WWDG Counting Maximum And Minimum Reset Time ( $APB1\text{ PCLK1} = 27\text{MHz}$ ).....	62
Table 4-36 I <sup>2</sup> C Interface Characteristics .....	63

**Table 4-37 SPI Characteristics <sup>(1)</sup>..... 64**

**Table 4-38 I<sup>2</sup>S Characteristics <sup>(1)</sup>..... 66**

**Table 4-39 USB Startup Time..... 68**

**Table 4-40 USB DC Characteristics..... 68**

**Table 4-41 Full Speed Of USB Electrical Characteristics ..... 69**

**Table 4-42 ADC Characteristics..... 69**

**Table 4-43 ADC Sampling Time<sup>(1) (2)</sup>..... 70**

**Table 4-44 ADC Accuracy-Limited Test Conditions <sup>(1) (2)</sup>..... 71**

**Table 4-45 V<sub>REFBUFF</sub> Characteristics ..... 73**

**Table 4-46 DAC Characteristics<sup>(1)</sup>..... 73**

**Table 4-47 OPAMP Characteristics<sup>(1)</sup>..... 74**

**Table 4-48 COMP2 Characteristics ..... 75**

**Table 4-49 COMP1 Normal Mode Characteristics..... 76**

**Table 4-50 COMP1 Low Power Mode Characteristics..... 76**

**Table 4-51 Temperature Sensor Characteristics..... 77**



## List of Figures

Figure 1-1 N32G435 Series Block Diagram.....	10
Figure 1-2 N32G435 Series Part Number Information .....	11
Figure 2-1 Memory Map.....	13
Figure 2-2 Clock Tree.....	15
Figure 3-1. N32G435 Series QFN28 Pinout .....	32
Figure 3-2 N32G435 Series LQFP32 Pinout.....	33
Figure 3-3 N32G435 Series LQFP48 Pinout.....	34
Figure 3-4 N32G435 Series LQFP64 Pinout.....	35
Figure 4-1 Load Conditions Of Pins.....	42
Figure 4-2 Pin Input Voltage .....	42
Figure 4-3 Power Supply Scheme.....	43
Figure 4-4 Current Consumption Measurement Scheme.....	43
Figure 4-5 AC Timing Diagram Of An External High-Speed Clock Source .....	50
Figure 4-6 AC Timing Diagram Of An External Low Speed Clock Source .....	51
Figure 4-7 Typical Application Using 8MHz Crystal .....	51
Figure 4-8 Typical Application Of 32.768kHz Crystal.....	52
Figure 4-9 Definition Of Input/Output AC Characteristics .....	60
Figure 4-10 Recommended NRST Pin Protection.....	61
Figure 4-11 I <sup>2</sup> C Bus AC Waveform And Measuring Circuit <sup>(1)</sup> .....	63
Figure 4-12 SPI Timing Diagram-Slave Mode And CPHA=0.....	65
Figure 4-13 SPI Timing Diagram-Slave Mode And CPHA=1 <sup>(1)</sup> .....	65
Figure 4-14 SPI Timing Diagram-Master Mode <sup>(1)</sup> .....	66
Figure 4-15 I <sup>2</sup> S Slave Mode Timing Diagram (Philips Protocol) <sup>(1)</sup> .....	67
Figure 4-16 I <sup>2</sup> S Master Mode Timing Diagram (Philips Protocol) <sup>(1)</sup> .....	68
Figure 4-17 USB Timing: Definition Of Rise And Fall Time Of Data Signal .....	69
Figure 4-18 ADC Precision Characteristics.....	72
Figure 4-19 Typical Connection Diagram Using ADC .....	72
Figure 4-20 Decoupling Circuit Of Power Supply And Reference Power Supply (V <sub>REF+</sub> is connected to V <sub>DDA</sub> ).....	73
Figure 5-1 QFN28(4mmx4mm) Package Dimensions .....	78
Figure 5-2 LQFP32(7mmx7mm) Package Dimensions.....	79
Figure 5-3 LQFP48(7mmx7mm) Package Dimensions.....	80
Figure 5-4 LQFP64 (10mmx10mm) Package Dimensions.....	81
Figure 5-5 LQFP64(7mmx7mm) Package Dimensions .....	82
Figure 5-6 Marking Information .....	83

# 1 Introduction

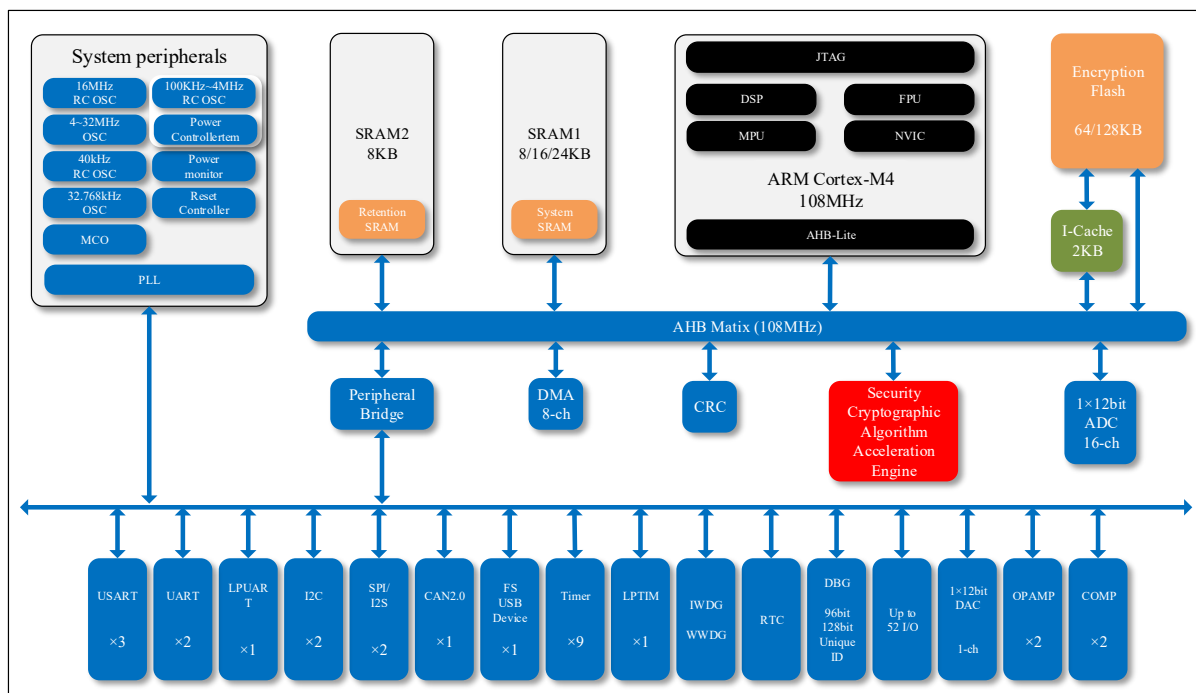
The N32G435 microcontrollers family features a high-performance 32-bit ARM Cortex™-M4F core with an integrated floating point operation unit (FPU) and digital signal processing (DSP). It supports parallel computing instructions and operates at a maximum frequency of 108MHz. The embedded encrypted memory Flash can hold up to 128KB, supporting multi-user partition permission management. Additionally, it includes up to 32KB of embedded SRAM, including 8KB of Retention RAM.

The device is equipped with internal high speed AHB bus, along with two low speed peripherals clock bus APB and bus matrix. It offers support up to 52 alternate I/Os and features a diverse range of high performance analog interfaces. These include a 12-bit 5MSPS ADC with up to 16 external input channels and 3 internal channels, as well as a 12-bit DAC with a 1MSPS sampling rate.

For digital communication, the N32G435 provides 5x U(S)ART, 1x LPUART, 2x I2C, 2x SPI/I2S, 1x FS USB 2.0 device, 1x CAN 2.0A/B communication interfaces, It also integrates a hardware acceleration engine, supporting various international encryption algorithms.

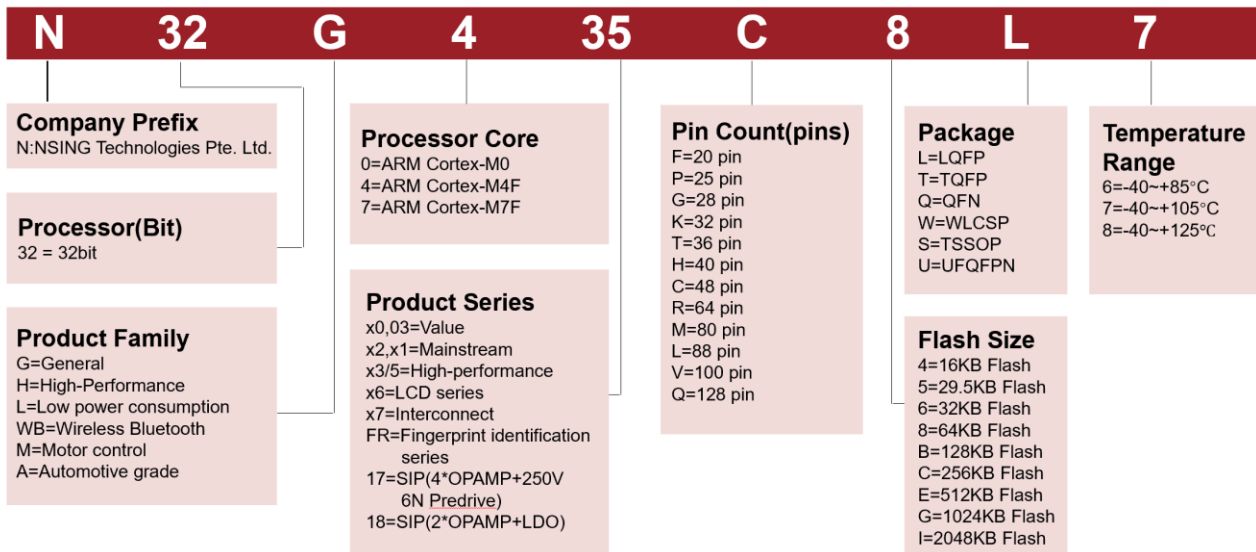
The N32G435 series operates reliably in the temperature range of -40°C to +105°C and supply voltage from 1.8V to 3.6V. It offers multiple power modes to cater to low-power applications. Available in 28/32/36/48/64- pin package, the peripheral configuration varies based on the package type.

**Figure 1-1 N32G435 Series Block Diagram.**



## 1.1 Naming Convention

Figure 1-2 N32G435 C 8 L 7



## 1.2 Product Configurations

**Table 1-1 N32G435 Series Product Configuration**

Device		N32G435G8/B		N32G435K8/B		N32G435C8/B		N32G435R8/B	
Flash Capacity (KB)		64	128	64	128	64	128	64	128
SRAM Capacity (KB)		16	32	16	32	24	32	24	32
CPU frequency		ARM Cortex-M4F @ 108MHz, 135DMIPS							
Operating environment		1.8~3.6V/-40~105°C							
Timers	General	5							
	Advanced	2							
	Basic	2							
	LPTIM	1							
Communication Interfaces	SPI <sup>(1)</sup>	1		2					
	I2S <sup>(1)</sup>	1		2					
	I2C	2							
	UART	2							
	USART	2		2		3			
	LPUART	1							
	USB	No <sup>(2)</sup>		1					
	CAN	No <sup>(2)</sup>		1					
GPIO		24		26		38		52	
DMA		1x							
DMA Channels		8 Channel							
12bit ADC		1x						1x	
ADC Channels		10 Channel						16 Channel	
12bit DAC		1x							
DAC Channels		1 Channel							
OPAMP/COMP		2/2							
Algorithm Support		DES/TDES, AES, SHA1/SHA224/SHA256 CRC16/CRC32, TRNG							
Security Protection		Read-write protection (RDP/WRP), storage encryption, partition protection, secure boot							
Package		QFN28		LQFP32		LQFP48		LQFP64	

Notes:

<sup>(1)</sup> SPI1 and SPI2 interfaces have the flexibility to switch between SPI mode and I2S audio mode.

<sup>(2)</sup> Not supported

## 2 Functional Overview

### 2.1 Processor Core

The N32G435 series integrates the latest generation of embedded ARM Cortex™-M4F processor. It features a floating point processing unit (FPU), DSP and parallel computing instructions, providing excellent performance of 1.25DMIPS/MHz. At the same time, its efficient signal processing capabilities combined with low power consumption, low cost, and ease of use. It is able to be used in application scenarios that require a blend of control and signal processing capabilities while being user-friendly.

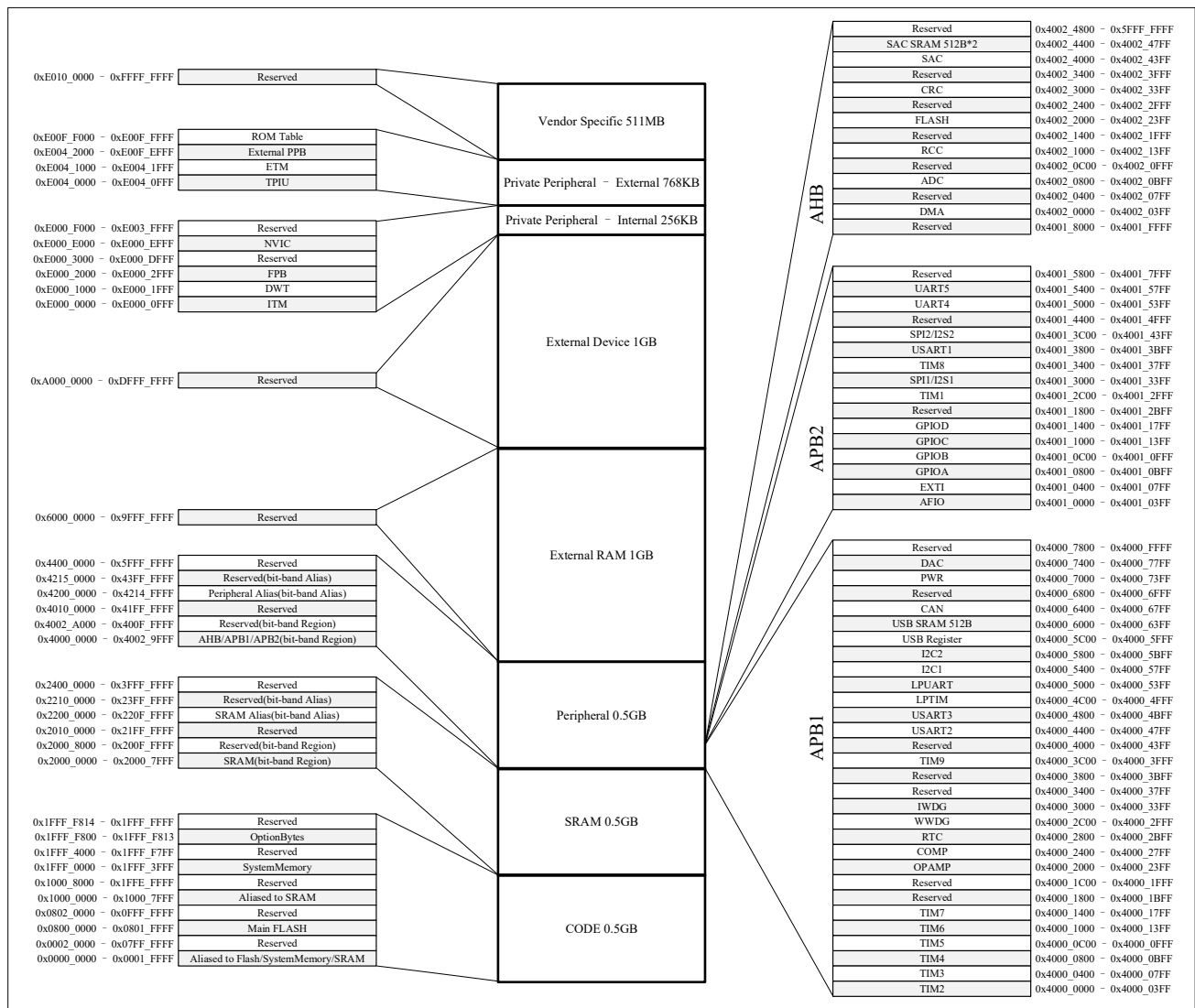
The ARM Cortex™-M4F 32-bit reduced instruction set processor offers exceptional code efficiency.

*Note: Cortex-M4F is backward compatible with Cortex-M3 code.*

### 2.2 Memories

The N32G435 series include embedded encrypted Flash memory and embedded SRAM.

Figure 2-1 Memory Map



### 2.2.1 Embedded FLASH Memory

The integrated encrypted Flash memory ranges from 64K to 128 K bytes, utilized for storing programs and data. The page size is 2K byte supporting page erasing, word writing, word reading, half-word reading, and byte reading operations.

It supports storage encryption protection, enabling automatic encryption during writing and decryption during reading (including program execution operation).

User partition management is supported, allowing for a maximum of 3 user partitions, different users cannot access each other's data (only executable code can be accessed).

### 2.2.2 Embedded SRAM

The chip integrates a built-in SRAM of up to 32K bytes, comprising SRAM1 and SRAM2. SRAM1 has a maximum size of 24K bytes, while SRAM2 has a maximum of 8K bytes. Both SRAM1 and SRAM2 can retain data in STOP2 mode. In STANDBY mode, only SRAM2 can retain data.

### 2.2.3 Nested Vector Interrupt Controller (NVIC)

The built-in Nested Vector Interrupt Controller can handle up to 66 maskable interrupt channels (excluding the 16 Cortex™-M4F interrupts) and 16 priorities.

- The tightly coupled NVIC ensures low-latency interrupt response processing.
- Interrupt vector entry addresses directly access the kernel.
- Allows early processing of interrupts.
- Processing late arriving higher priority interrupts.
- Support interrupt tail-chaining functionality.
- Automatically saves processor state.
- Automatically resumes when interrupt returns with no instruction overhead.

This module offers flexible interrupt management with minimal interrupt latency.

## 2.3 Extended Interrupt/Event Controller (EXTI)

The extended interrupt/event controller contains 25 edge detectors used for generating interrupt/event requests. Each interrupt line can be independently configured with its trigger event (rising edge, falling edge or both) and can be individually masked. A pending register maintains the state of all interrupt requests. EXTI can detect clock pulse with widths smaller than internal APB2 clock cycle. Up to 52 general-purpose I/O ports are connected to 16 external interrupts lines.

## 2.4 Clock System

The device offers various clock options for users to choose from, including:

- High speed internal RC oscillator (HSI) at 16MHz.
- Multi-speed internal RC oscillator (MSI) ranging from 100K to 4MHz, configurable.
- Low speed internal RC oscillator (LSI) at 40KHz.
- High speed external crystal oscillator (HSE) ranging from 4MHz to 32MHz.
- Low speed external crystal oscillator (LSE) at 32.768KHz.
- Phase-Locked Loop (PLL).

Upon reset, the internal MSI clock is set as the default CPU clock, user can choose the external HSE clock with fail function. When an external clock failure is detected, it will be isolated, the system will automatically switch to MSI. If interrupts are enabled, software can receive corresponding interrupts. Similarly the system will automatically switch to MSI when the PLL clock was adopted and external oscillator fails.

The MSI clock can be used for fast wake up and instruction execution in STOP2 state, or to provide clock for the system

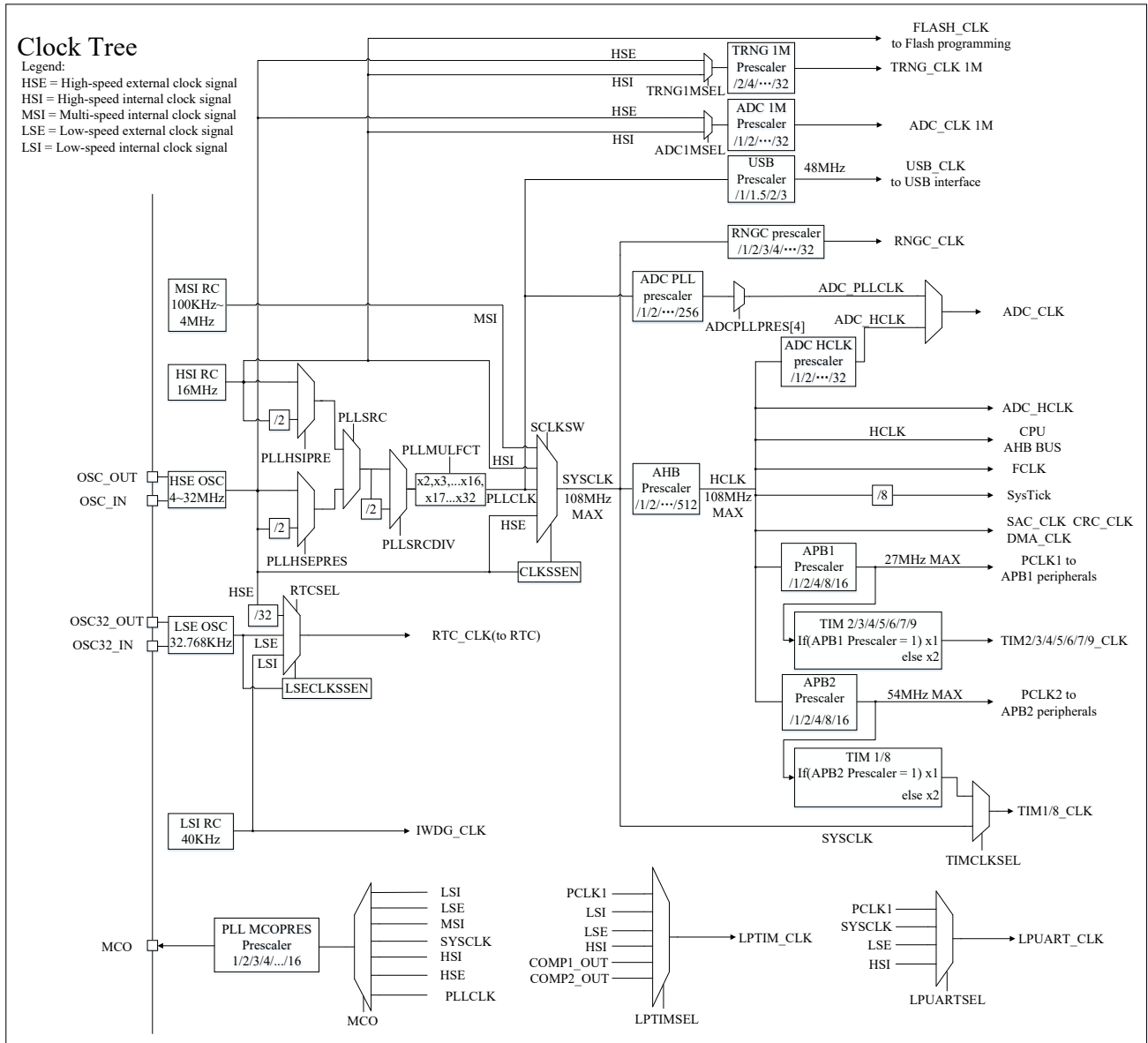
in low power operation, and some other scenarios with low clock accuracy and high-power consumption requirements.

There is a built-in clock security system, when enables by the user, can detect in real-time whether the external HSE or LSE has fails. Once an external clock failure is detected, the system automatically switches to the internal clock and generates an interrupt alert.

Multiple prescalers are used to configure the AHB frequency, high speed APB (APB2) and low speed APB (APB1) regions. The AHB has a maximum frequency of 108MHz, APB2 has a maximum frequency of 54MHz and APB1 has a maximum frequency of 27MHz.

When using USB function, both HSE and PLL must be used and the CPU frequency must be 48MHz, 72MHz or 96MHz.

**Figure 2-2 Clock Tree**



## 2.5 Boot Modes

During startup, the BOOT mode after reset can be selected through the BOOT0 pin and option byte BOOT configuration (USER2):

- Boot from FLASH memory
- Boot from system memory
- Boot from embedded SRAM

The Bootloader is stored in the system memory and can program the flash memory through USART1 or USB interface.

## 2.6 Power Supply Scheme

- $V_{DD} = 1.8\sim 3.6V$ : The  $V_{DD}$  pin supplies power to the I/O pin and the internal voltage regulator.
- $V_{DDA} = 1.8\sim 3.6V$ : The  $V_{DDA}$  provides power supply for ADC, DAC, OPAMP and COMP.
- $V_{DDA}$  and  $V_{SSA}$  must be connected to  $V_{DD}$  and  $V_{SS}$  respectively. See **Figure 4-3 Power Supply Scheme**.

## 2.7 Reset

POR and BOR circuits are integrated inside the device. This part of the circuit ensure that the system works stably when the power supply exceeds 1.8V. When  $V_{DD}$  falls below a set threshold ( $V_{POR/BOR}$ ), the device goes into reset state without using an external reset circuit.

## 2.8 Programmable Voltage Detector

The device has a built-in programmable voltage detector (PVD), which monitors the power supply of  $V_{DD}$  and compares it with the threshold  $V_{PVD}$ . When  $V_{DD}$  is lower or higher than the threshold  $V_{PVD}$ , an interrupt will be generated. The interrupt handler can send a warning message, and the PVD function needs to be enabled through the program. See **Table 4-6** for values of  $V_{POR/PDR}$  and  $V_{PVD}$ .

## 2.9 Voltage Regulator

The voltage regulator has two control modes:

- Main mode: The MCU operates in RUN, SLEEP modes.
- Low power mode, The MCU operates in LP RUN, LP SLEEP, STOP2, and STANDBY modes.

The voltage regulator is always in the main mode after the MCU reset.

## 2.10 Low Power Mode

The N32G435 series supports five low-power modes.

- LP-RUN mode

In LP-RUN (Low Power RUN) mode, the CPU operates using MSI clock, executing programs stored in FLASH or SRAM, with the PLL turned off. USB/CAN/algorithm (CRYE) module are disabled, while other peripherals can be configurable as needed.

- SLEEP mode

In SLEEP mode, only the CPU is stopped, all peripherals remain operational. They can wake up the CPU when an interrupt/event occurs.

- LP-SLEEP mode

In LP-SLEEP (Low Power SLEEP) mode, the CPU is stopped, the PLL is turned off, and the USB/CAN/CRYE module



are disabled, Other peripherals can be configured as needed, and all IOs remain in the same state as in RUN mode.

- STOP2 mode

In STOP2 mode, all the core digital logic areas are powered off.

- The Main voltage regulator (MR) is turned off,
- HSE/HSI/MSI/PLL is turned off.
- CPU registers are retained.
- LSE/LSI can be configured to operate.
- GPIOs are retained,
- SRAM1 and SRAM2 can be retained
- SPI, USART/UART, I2C, WWDG are retained.
- 80 bytes backup register are retained.
- RET and low power domains operate normally.

Wakeup: The device can be woken up from STOP2 mode by any of the 16 external EXTI signals (I/O related), WKUP pin wakeup, RTC periodic wake up, RTC alarm, RTC tamper, RTC timestamp, NRST reset, IWDG reset.

- STANDBY Mode

In STANDBY mode, the device can achieve a lower current consumption. The internal voltage regulator is turned off, as well as PLL, HSI RC oscillator and HSE crystal oscillator, only LSE and LSI can optionally work. Upon entering STANDBY mode, the contents of the main domain registers will be lost, SRAM2 can optionally be retained, the STANDBY circuitry continues to function.

External reset signal on NRST, IWDG reset, rising/falling edge on the WKUP pin, RTC alarm, RTC timestamp and RTC tamper can wake up the device from STANDBY mode.

*Note: RTC, IWDG and corresponding clock cannot be stopped when entering standby mode.*

## 2.11 Direct Memory Access (DMA)

The device integrates a flexible general-purpose DMA controller that supports eight DMA channels. It can manage data transfers from memory to memory, peripherals to memory, and memory to peripherals. The DMA controller supports the management of circular buffers, thus avoiding interrupts when the controller reaches the end of the buffer.

Each channel has dedicated hardware DMA request logic and each channel can be triggered by software. The transmission length, source address and destination address of each channel can be set separately by software.

DMA can be used with major peripherals: SPI, I2C, USART, TIMx (Advanced/General/Basic Timers), DAC, I2S and ADC.

## 2.12 Real Time Clock (RTC)

The RTC is a set of continuously running counters integrated with a built-in calendar clock module that provides a perpetual calendar functionality, as well as alarm interrupt and periodic interrupt (with a minimum 2 clock cycles). The RTC will not be reset by the system or power reset source, nor will it be reset when woken up from STANDBY mode.

The RTC can be driven by either a 32.768kHz external crystal oscillator, an internal low power 40kHz RC oscillator, or a high-speed external clock with 128 frequency divisions.

For application scenarios requiring very high timing accuracy, it is recommended to use an external 32.768kHz clock as the clock source, to compensate for the clock deviation of natural crystal, a 256Hz signal can be output to calibrate the clock of RTC.

The RTC features a 22-bit prescaler for a time based clock. By default, when the clock is set to 32.768kHz, it generates a 1-second time reference. In addition, the RTC can be used to trigger wakeup in low-power mode.

## 2.13 Timers And Watchdogs

Up to 2 advanced control timers, 5 general-purpose timers and 2 basic timers, 1 low power timer, 2 watchdog timers and 1 system tick timer.

The following table compares the functions of advanced control timer, general-purpose timer and basic timer:

**Table 2-1 Comparison Of Timer Functions**

Timer	Counter Resolution	Counter Type	Prescaler Factor	Generate DMA Requests	Capture/Compare Channels	Complementary Output
TIM1 TIM8	16	Up, down, up/down	Any integer between 1 and 65536	Y	4	Y
TIM2 TIM3 TIM4 TIM5 TIM9	16	Up, down, up/down	Any integer between 1 and 65536	Y	4	N
TIM6 TIM7	16	up	Any integer between 1 and 65536	Y	0	N

### 2.13.1 Low Power Timer (LPTIM)

The LPTIM is a 16-bit timer with multiple clock sources, it can keep running in all power modes except for Standby mode. LPTIM can run without internal clock source as a “Pulse Counter”. Also, the LPTIM can wake up the system from low-power modes, to realize “Timeout functions” with extremely low power consumption.

Main features:

- 16-bit up counter
- 3-bit prescaler, 8 kinds of prescaler factors (1, 2, 4, 8, 16, 32, 64, 128)
- Multiple clock sources:
  - Internal clock source: LSE, LSI, HSI, PCLK1, COMP1\_OUT or COMP2\_OUT
  - External clock source: External clock source through LPTIM Input1 (operating without LP oscillator, for pulse counter applications)
- 16-bit auto-load register (LPTIM\_ARR)
- 16-bit compare register (LPTIM\_COMP)
- Continuous or one-shot mode counting mode
- Programmable software or hardware input trigger
- Programmable digital filter for glitch filtering
- Configurable output (square wave, PWM)
- Configurable IO polarity
- Encoder mode
- Pulse counting mode, support single pulse counting, double pulse counting (quadrature and non-quadrature)

### 2.13.2 Basic Timer (TIM6 and TIM7)

Basic timers TIM6 and TIM7 each contain a 16-bit auto-reload counter. These two timers are independent of each other and do not share any resources. The basic timer can provide a time base for general purpose timers, and for a digital-to-analog converter (DAC). The basic timer is directly connected to the DAC inside the chip and drives the DAC directly

through the trigger output.

Main features:

- 16-bit auto-reload up-counting counters
- 16-bit programmable prescaler. (The prescaler factor can be configured with any value between 1 and 65536)
- Synchronization circuit for triggering DAC
- Event that generate the interrupt/DMA is as follows:
  - Update event

### 2.13.3 General-Purpose Timer (TIMx)

The general-purpose timers (TIM2, TIM3, TIM4, TIM5 and TIM9) is mainly used in the following occasions: counting the input signal, measuring the pulse width of the input signal and generating the output waveform, etc.

Main features:

- 16-bit auto-reload counters. (It can realize up-counting, down-counting, up/down counting)
- 16-bit programmable prescaler. (The prescaler factor can be configured with any value between 1 and 65536)
- TIM2, TIM3, TIM4, TIM5 and TIM9 up to 4 channels
- Channel's working modes: PWM output, output compare, one-pulse mode output, input capture
- The events that generate the interrupt/DMA are as follows:
  - Update event
  - Trigger event
  - Input capture
  - Output compare
- Timer can be controlled by external signal
- Timers can be linked together internally for timer synchronization or chaining
- Incremental (quadrature) encoder interface: used for tracking motion and resolving rotation direction and position
- Hall sensor interface: used to do three-phase motor control
- Supports capture of internal comparator output signals. TIM9 supports capture of internal HSE, LSI, and LSE signals

### 2.13.4 Advanced Control Timer (TIM1 and TIM8)

The advanced control timers (TIM1 and TIM8) is mainly used in the following purposes: counting the input signal, measuring the pulse width of the input signal and generating the output waveform, etc.

Advanced timers have complementary output function with dead-time insertion and break function. They are suitable for motor control.

Main features:

- 16-bit auto-reload counters. (It can realize up-counting, down-counting, up/down counting)
- 16-bit programmable prescaler. (The prescaler factor can be configured with any value between 1 and 65536)
- Programmable Repetition Counter
- TIM1 and TIM8 up to 4 capture/compare channels:
  - PWM output
  - Output compare

- One-pulse mode output
- Input capture
- The events that generate the interrupt/DMA are as follows:
  - Update event
  - Trigger event
  - Input capture
  - Output compare
  - Break input
- Complementary outputs with programmable dead-time
  - For TIM1 and TIM8, channel 1,2,3 support this feature
- Timer can be controlled by external signal
- Timers can be linked together internally for timer synchronization or chaining
- TIM1\_CC5 and TIM8\_CC5 for COMP blanking
- TIM1\_CC6 is used to switch the input channel of OPAMP1 and OPAMP2; TIM8\_CC6 can switch the input channel of OPAMP2
- Incremental (quadrature) encoder interface: used for tracking motion and resolving rotation direction and position
- Hall sensor interface: used to do three-phase motor control

### 2.13.5 SysTick Timer

This timer is dedicated to real-time operating systems and can also be used as a standard down-counter.

Main features:

- 24 bit down-counter
- Automatic reloading function
- A maskable system interrupt is generated when the counter is 0
- Programmable clock source

### 2.13.6 Watchdog (WDG)

Support for two watchdog independent watchdog (IWDG) and window watchdog (WWDG). Two watchdogs provide increased security, time accuracy, and flexibility in use.

#### Independent watchdog (IWDG)

The independent watchdog is based on a 12-bit down-counter and a 3-bit prescaler. It is driven by a separate low-speed RC oscillator that remains active even if the master clock fails and operates in STOP2 and STANDBY modes. Once activated, if the watchdog is not fed (clears the watchdog counter) within the set time, the IWDG generates a reset when the counter counts to 0x000. It can be used to reset the entire system in the event of an application problem, or as a free timer to provide time-out management for applications. It is hardware or software configurable through the option bytes. Reset and low power wake up are available.

#### Window watchdog (WWDG)

A window watchdog is usually used to detect software failures caused by an application deviating from the normal running sequence due to external interference or unforeseen logical conditions. Unless the down-counter value is flushed before the T6 bit becomes 0, the watchdog circuit generates an MCU reset when the preset time period is reached. If the 7-bit down-counter value (in the control register) is flushed before the down-counter reaches the window register value, then an MCU reset will also occur. This indicates that the down-counter needs to be refreshed in a finite time window.

Main features:

- The clock of the window watchdog (WWDG) is obtained by dividing the APB1 clock frequency by 4096.
- Programmable free-running down-counter
- Reset condition:
  - When the down-counter is less than 0x40, a reset occurs (if the watchdog is started)
  - A reset occurs when the down-counter is reloaded outside the window (if the watchdog is started)
  - If the watchdog is enabled and interrupts are allowed, an early wake up interrupt (EWINT) occurs when the down-counter equals 0x40, which can be used to reload the counter to avoid WWDG reset

## 2.14 I<sup>2</sup>C Bus Interface

The device integrates up to two independent I2C bus interfaces, which provide multi-host function and control all I2C bus-specific timing, protocol, arbitration and timeout. I2C bus interface supports multiple communication rate modes (up to 1MHz), supports DMA operations and is compatible with SMBus 2.0. The I2C module provides multiple functions, including CRC generation and verification, SMBus (System Management Bus) and PMBus (Power Management Bus).

Main features:

- Multi-master function: this module can be used as master device or slave device.
- I2C master device function:
  - Generate a clock.
  - Generate start and stop signals.
- I2C slave device function:
  - Programmable address detection
  - The I2C interface supports 7-bit or 10-bit addressing and dual-slave addresses response capability in 7-bit slave mode.
  - Stop bit detection.
- Generate and detect 7-bit/10-bit addresses and broadcast calls.
- Support different communication speeds.
  - Standard speed (up to 100 kHz)
  - Fast (up to 400 kHz)
  - Fast+ (up to 1MHz)
- Status flags:
  - Transmitter/receiver mode flag
  - Byte transfer complete flag
  - I2C bus busy flag
- Error flags:
  - Arbitration loss in master mode
  - Acknowledge (ACK) fail after address/data transfer.
  - Error start or stop condition detected.
  - Overrun or underrun when clock extending is disable.
- Two interrupt vectors:
  - 1 interrupt for address/data communication success
  - 1 interrupt for an error

- Optional extend clock function.
- DMA of single-byte buffers
- Generation or verification of configurable PEC(Packet error checking)
- In transmit mode, the PEC value can be transmitted as the last byte.
- PEC error check for the last received byte.
- SMBus 2.0 compatible
  - Timeout delay for 25ms clock low
  - 10ms accumulates low clock extension time of master device.
  - 25ms accumulates low clock extension time of slave device.
  - PEC generation/verification of hardware with ACK control.
  - Support address resolution protocol (ARP)
- Compatible with the PMBus

## 2.15 Universal Synchronous/Asynchronous Transceiver (USART)

The N32G435 series products integrate up to 5 serial transceiver interfaces, including 3 universal synchronous/asynchronous transceivers (USART1, USART2 and USART3) and 2 universal asynchronous transceivers (UART4 and UART5). All five interfaces provide asynchronous communication, support for IrDA SIR ENDEC transmission codec, multi-processor communication mode, single-wire half-duplex communication mode, and LIN master/slave function.

The USART1, USART2, and USART3 interfaces have hardware CTS and RTS signal management, ISO7816-compatible Smartcard mode, and similar to SPI communication mode, all of which can use DMA operations.

Main features:

- Full duplex, asynchronous communication
- NRZ standard format
- Fractional baud rate generator system, baud rate programmable, used for sending and receiving
- Programmable data word length (8 or 9 bits)
- Configurable stop bit, supporting 1 or 2 stop bits
- LIN master's ability to send synchronous interrupters and LIN slave's ability to detect interrupters. When USART hardware is configured as LIN, it generates 13 bit interrupters and detects 10/11 bit interrupters
- Output clock for synchronous transmission.
- IRDA SIR encoder decoder, supports 3/16 bit duration in normal mode
- Smartcard simulation function:
  - The smart card interface supports the asynchronous smart card protocol defined in ISO7816-3
  - 0.5 and 1.5 stop bits for smart cards.
- Single-wire half duplex communication
- Configurable multi-buffer communication using DMA, receiving/sending bytes in SRAM using centralized DMA buffer
- Independent transmitter and receiver enable bits.
- Detect flag:
  - Receive buffer is full.

- Send buffer empty
- Transmission complete
- Parity control:
  - Send parity bit
  - Check the received data
- Four error detection flags:
  - Overflow error
  - Noise error
  - Frame error
  - Parity error
- 10 USART interrupt sources with flags:
  - CTS change
  - LIN break detection
  - Send data register empty
  - Send complete
  - Received data register is full
  - Bus was detected to be idle
  - Overflow error
  - Frame error
  - Noise error
  - Parity error
- Multi-processor communication, if the address does not match, then enter the silent mode
- Wake up from silent mode (via idle bus detection or address flag detection)
- Mode configuration:

USART modes	USART1	USART2	USART3	UART4	UART5
Asynchronous mode	support	support	support	support	support
Hardware flow control	support	support	support	nonsupport	nonsupport
Multiple buffer communication (DMA)	support	support	support	support	support
Multiprocessor communication	support	support	support	support	support
Synchronous mode	support	support	support	nonsupport	nonsupport
Smartcard mode	support	support	support	nonsupport	nonsupport
Half duplex (Single wire mode)	support	support	support	support	support
IrDA	support	support	support	support	support
LIN	support	support	support	support	support

## 2.16 Low Power Asynchronous Transceiver (LPUART)

The device integrates a low-power asynchronous serial transceiver (LPUART), which can receive data in STOP2 state (maximum baud rate 9600) and wake up MCU after generating an interrupt event. In addition, by configuring the clock as

a high-speed clock (such as APB or HSE clock), it can be used as a regular asynchronous serial port to support higher baud rates.

Main features:

- Provide standard asynchronous communication bits (start, parity, and stop bits)
  - Generates 1 start bit
  - Generates 1-bit parity bit (odd or even parity can be set) or no parity bit
  - Generates 1 stop bit
  - Bytes are transmitted from the lowest to the highest
- Support 32 bytes Receive FIFO and 1 byte Transmit FIFO
- Provides transmit mode control bits
- Programmable baud rate
- Full duplex communication
- Support data communication and error handling interruption
- Access to status bits can be done in two ways: query or interrupt
- Parity error flag
- Baud rate parameter register
- Support hardware flow control
- Support DMA data transfer
- Support the following interrupt event sources to wake up the MCU in STOP2 state:
  - Start bit detection
  - Receive buffer non-empty detection
  - Received the specified 1 bytes of data
  - Received the specified 4 bytes of data

## 2.17 Serial Peripheral Interface (SPI)

The device integrates two SPI interfaces, which allow the chip to communicate with peripheral devices in half/full duplex, synchronous, serial manner modes. This interface can be configured in master mode and provides a communication clock (SCK) for external slave devices. Interfaces can also work in a multi-master configuration. It can be used for a variety of purposes, including two-line simplex synchronous transmission using a two-way data line, and reliable communication using CRC checks.

Main features:

- 3-wire full-duplex synchronous transmission
- Two-wire simplex synchronous transmission with or without a third bidirectional data line
- 8 or 16 bit transmission frame format selection
- Master or slave operations
- Support multi-master mode
- 8 master mode baud rate prescaler coefficient (Max  $f_{\text{CLK}}/2$ )
- Slave mode frequency (Max  $f_{\text{CLK}}/2$ )
- Fast communication between master mode and slave mode



- NSS can be managed by software or hardware in both master and slave modes: dynamic change of master/slave modes
- Programmable clock polarity and phase
- Programmable data order, MSB before or LSB before
- Dedicated send and receive flags that trigger interrupts
- SPI bus busy flag
- Hardware CRC for reliable communication:
  - In send mode, the CRC value can be sent as the last byte
  - In full-duplex mode, CRC is automatically performed on the last byte received
- Master mode failures, overloads, and CRC error flags that trigger interrupts
- Single-byte send and receive buffer with DMA capability: generates send and receive requests
- Maximum interface speed: 27Mbps

## 2.18 Serial Audio Interface (I<sup>2</sup>S)

I<sup>2</sup>S is a 3-pin synchronous serial interface communication protocol. The device integrates two standard I<sup>2</sup>S interfaces (multiplexed with SPI) and can operate in master or slave mode. The two interfaces can be configured for 16-bit, 24-bit or 32-bit transmission, or as input or output channels, supporting audio sampling frequencies from 8kHz to 96kHz. It supports four audio standards, including Philips I<sup>2</sup>S, MSB and LSB alignment, and PCM.

In half duplex communication, It can operate in two modes: master and slave. When it acts as a master device, it provides clock signals to external slave devices through an interface.

Main features:

- Simplex communication (transmit or receive only)
- Master or slave operations
- 8-bit linear programmable prescaler for accurate audio sampling frequencies (8KHz to 96KHz)
- The data format can be 16, 24, or 32 bits
- Audio channel fixed packet frame is 16 bit (16 bit data frame) or 32 bit (16, 24 or 32 bit data frame)
- Programmable clock polarity (steady state)
- The overflows flag bit in slave sending mode and the overflows flag bit in master/slave receiving mode
- 16-bit data registers are used for sending and receiving, with one register at each end of the channel
- Supported I<sup>2</sup>S protocols:
  - I<sup>2</sup>S Philips standard
  - MSB alignment standard (left aligned)
  - LSB alignment standard (right aligned)
  - PCM standard (16-bit channel frame with long or short frame synchronization or 16-bit data frame extension to 32-bit channel frame)
- The data direction is always MSB first
- Both send and receive have DMA capability
- The master clock can be output to external audio devices at a fixed rate of 256xFs(Fs is the audio sampling frequency)

## 2.19 Controller Area Network (CAN)

The device integrates a CAN bus interface compatible with 2.0A and 2.0B (active) specifications, with bit rates up to 1Mbps. It can receive and send standard frames with 11-bit identifiers, as well as extended frames with 29-bit identifiers.

Main features:

- Supports CAN protocol 2.0A and 2.0B active mode
- Baud rate up to 1Mbps
- Supports time-triggered communication
- Transmit:
  - Three transmitting mailboxes
  - The priority of sent packets can be configured by software
  - Records the timestamp of the time when the SOF was sent
- Receive:
  - Level 3 depth of 2 receiving FIFO
  - Variable filter group
  - There are 14 filter groups
  - Identifier list
  - The FIFO overflow processing mode is configurable
  - Record the time stamp of the receipt of the SOF
- Time-triggered communication mode:
  - Disable automatic retransmission mode
  - 16-bit free run timer
  - Timestamp can be sent in the last 2 bytes of data
- Management:
  - Interrupt masking
  - The mailbox occupies a separate address space to improve software efficiency

## 2.20 Universal Serial Bus (USB)

The device is embedded with a full speed USB compatible device controller that follows the full speed USB device (12Mbit/s) standard. The endpoint can be configured by software and has suspend/resume function. The USB dedicated 48MHz clock is generated directly from the internal PLL.

Main features:

- Comply with the technical specifications of USB2.0 full-speed equipment
- 1 to 8 USB endpoints can be configured
- CRC(cyclic redundancy check) generation/check, reverse non-return to zero (NRZI) encoding/decoding and bit filling
- Double buffer mechanism for bulk/isochronous endpoints
- Support USB suspend/resume operation
- Frame lock clock pulse generation

- Integrated pull-up 1.5K resistor for USB DP signal line (user can enable or disable through software control)

## 2.21 General-Purpose Input/Output Interface (GPIO)

Up to 52 GPIOs, which can be divided into four groups (GPIOA/GPIOB/GPIOC/GPIOD). Each group of GPIOA, GPIOB, GPIOC and GPIOD has 16 ports. Each GPIO pin can be configured by software as an output (push pull or open drain), input (with or without pull-up or pull-down), or alternate peripheral function port. Most GPIO pins are shared with digital or analog alternate peripherals, and some I/O pins are multiplexed with clock pins. All GPIO pins have high current passing capability except ports with analog input capability.

Main features:

- Each bit of the GPIO port can be configured separately by the software into multiple modes:
  - Input floating
  - Input pull up (weak pull up)
  - Input pull down (weak pull down)
  - Analog function
  - Open drain output
  - Push-pull output
  - Push-pull alternate function
  - Open drain alternate function
- General I/O (GPIO)
  - During and just after reset, the alternate function is not enabled, except for BOOT0 (which is an input pull-down), and the I/O port is configured to analog input mode
  - After reset, the default state of pins associated with the debug system is enable SWJ, the JTAG pin is placed in input pull-up or pull-down mode:
    - JTDI in pull-up mode
    - JTCK in pull-down mode
    - JTMS in pull-up mode
    - NJTRST in pull-up mode
  - When configured as output, values written to the output data registers are output to the appropriate I/O pins. Can be output in push pull mode or open drain mode
- Separate bit setting or bit clearing functions
- External interrupt/wake up: All ports have external interrupt capability. In order to use external interrupts, ports must be configured in input mode
- Alternate function: (port configuration registers must be programmed before using default alternate function)
- GPIO lock mechanism, which freezes I/O configurations. When a LOCK is performed on a port bit, the configuration of the port bit cannot be changed until the next reset

## 2.22 Analog/Digital Converter (ADC)

The device supports a 12-bit Successive Approximation Register (SAR) ADC with a sampling rate of 5MSPS. It supports both single-ended and differential inputs, capable of measuring 16 external and 3 internal sources.

Main features:

- Support 12/10/8/6-bits resolution configurable.
  - The maximum sampling rate at 12bit resolution is 5.14MSPS.
  - The maximum sampling rate at 10bit resolution is 6MSPS
  - The maximum sampling rate at 8bit resolution is 7.2MSPS.
  - The maximum sampling rate at 6bit resolution is 9MSPS.
- ADC clock source is divided into working clock source, sampling clock source and timing clock source.
  - AHB\_CLK can be configured as the working clock source, up to 108MHz.
  - PLL can be configured as a sampling clock source, up to 72MHZ, support 1, 2, 4, 6, 8, 10, 12, 16, 32, 64, 128, 256 frequency division.
  - The AHB\_CLK can be configured as the sampling clock source, up to 72MHz, and supports frequency 1,2,4,6,8,10,12,16,32.
  - The timing clock is used for internal timing functions and the frequency must be configured to 1MHz.
- Supports timer trigger ADC sampling.
- Support 2.048V internal reference voltage  $V_{REFBUFFER}$
- Interrupts when conversion ends, injection conversion ends, and analog watchdog events occur.
- Single and continuous conversion modes
- Automatic scan mode from channel 0 to channel N
- Support for self-calibration.
- Data alignment with embedded data consistency
- Sampling intervals can be programmed separately by channel.
- Both regular conversions and injection conversions have external triggering options
- Continuous mode
- ADC power supply requirements: 1.8V to 3.6V
- ADC input range:  $V_{REF-} \leq V_{IN} \leq V_{REF+}$
- ADC can use DMA operations, and DMA requests are generated during regular channel conversion.
- Analog watchdog function can monitor one, multiple, or all selected channels with great precision. When the monitored signal exceeds the preset threshold, an interruption will occur.

## 2.23 Operational Amplifier (OPAMP)

The device integrates up to 2 independent operational amplifiers with multiple operating modes such as external amplifier, internal follower, and programmable amplifier (PGA) (or both internal amplifier and external filter).

Main features:

- Support rail-to-rail input
- Forward and reverse input checkboxes
- OPAMP working mode can be configured as:
  - Independent mode (external gain setting)
  - PGA mode, programmable gain ranging of 2X, 4X, 8X, 16X, 32X
  - Follower mode

- The internally connected ADC channel is used to measure the output signal of the operational amplifier.

## 2.24 Analog Comparator (COMP)

The device integrates up to 2 comparators, among which COMP1 supports low power mode and can work in STOP2 state. It can be used as a separate device (all ports of the comparator are plugged into the I/O) or in combination with a timer. In the case of motor control, it can be combined with the PWM output from the timer to form periodic current control.

Main features:

- Rail-to-rail comparators are supported.
- The reverse and forward sides of the comparator support the following inputs.
  - Optional I/O
  - DAC channel output
  - 64 level adjustable internal reference voltage input:
    - VREF1 is a low-power reference voltage source, which can only be used for COMP1.
    - VREF2 is a non-low power reference voltage source, which can be used for COMP1 and COMP2
- Programmable hysteresis can be configured as no hysteresis, low hysteresis, medium hysteresis, and high hysteresis.
- The comparator can output to I/O or timer input for triggering.
  - Capture events.
  - OCREF\_CLR events (for periodic current control)
  - The brake events.
- The comparator supports output filtering, including analog and digital filtering.
- COMP1/COMP2 can form a window comparator.
- Support comparator output with blanking, you can choose forbidden energy blanking or Timer1\_OC5, Timer8\_OC5 as blanking input.
- Each comparator can have interrupt wake up capability, support from SLEEP mode wake up, COMP1 can support under STOP2 wake up.

## 2.25 Digital/Analog Converter (DAC)

The device integrates a digital to analog converter (DAC), which is a 12-bit digital input and voltage output digital/analog converter with an output channel of built-in Buffer. DAC can be referenced via  $V_{DDA}$  or  $V_{REFBUFFER}$ .

Main features:

- An output channel for a built-in Buffer
- Configurable 8/12-bits output
- Configurable left or right data alignment in 12-bit mode
- Synchronous update function
- Generation of noise wave
- Generation of triangular wave
- DMA support
- External triggers for conversion

## 2.26 Temperature Sensor (TS)

The temperature sensor generates a voltage that varies linearly with temperature in the range of  $1.8V < V_{DDA} < 3.6V$ . The temperature sensor is internally connected to the ADC\_IN17 input channel for converting the output of the temperature sensor to digital values.

## 2.27 Cyclic Redundancy Check Calculation Unit (CRC)

The device integrates CRC32 and CRC16 functionalities. The cyclic redundancy check (CRC) calculation unit is based on a fixed generation polynomial to obtain arbitrary CRC calculation results. In many applications, CRC-based techniques are used to verify data transfer or storage consistency. Within the scope of the EN/IEC 60335-1 standard, it provides a means of detecting flash memory errors. The CRC unit can be used to calculate signatures of software in real time and compare them with signatures generated during the link-time and generating of the software.

Main features:

- CRC16: supports polynomials  $X^{16} + X^{15} + X^2 + 1$
- CRC32: supports polynomials  $X^{32} + X^{26} + X^{23} + X^{22} + X^{16} + X^{12} + X^{11} + X^{10} + X^8 + X^7 + X^5 + X^4 + X^2 + X + 1$
- CRC16 calculation time: 1 AHB clock cycles (HCLK)
- CRC32 calculation time: 1 AHB clock cycles (HCLK)
- The initial value for cyclic redundancy computing is configurable.
- Supports DMA mode

## 2.28 Secure Algorithm Co-processor (SAC)

The device features a secure algorithm co-processor, it supports a variety of international algorithms hash cryptography algorithm acceleration, which can greatly improve the speed of encryption and decryption compared with pure software algorithm.

The hardware supports the following algorithms:

- Supports DES symmetric algorithms
  - DES and 3DES encryption and decryption operations are supported
  - TDES supports 2KEY and 3KEY mode
  - Supports CBC and ECB mode
- Supports the SYMMETRIC AES algorithm
  - Supports 128bits, 192bits, or 256bits key length
  - Supports CBC, ECB, and CTR mode
- SHA hash algorithm is supported
  - Supports SHA1, SHA244, SHA256
- Supports the MD5 digest algorithm

## 2.29 Unique Device Serial Number (UID)

The N32G435 series products have two built-in unique device serial numbers of different lengths, which are 96-bit unique device ID (UID) and 128-bit unique customer ID (UCID). These two device serial numbers are stored in the system configuration block of Flash memory. The information they contain is written at the time of delivery and is guaranteed to be unique to any of the N32G435 series microcontrollers under any circumstances and can be read by user applications or external devices through the CPU or JTAG/SWD interface and cannot be modified.

The 96-bit UID is usually used as a serial number or password. When writing Flash memory, this unique identifier is combined with software encryption and decryption algorithm to further improve the security of code in Flash memory. It can also be used to activate Secure Bootloader with security functions.

The UCID is 128-bit, which complies with the definition of national technology chip serial number. It contains the information related to chip production and version.

### **2.30 Serial Single-Wire JTAG Debug Port (SWJ-DP)**

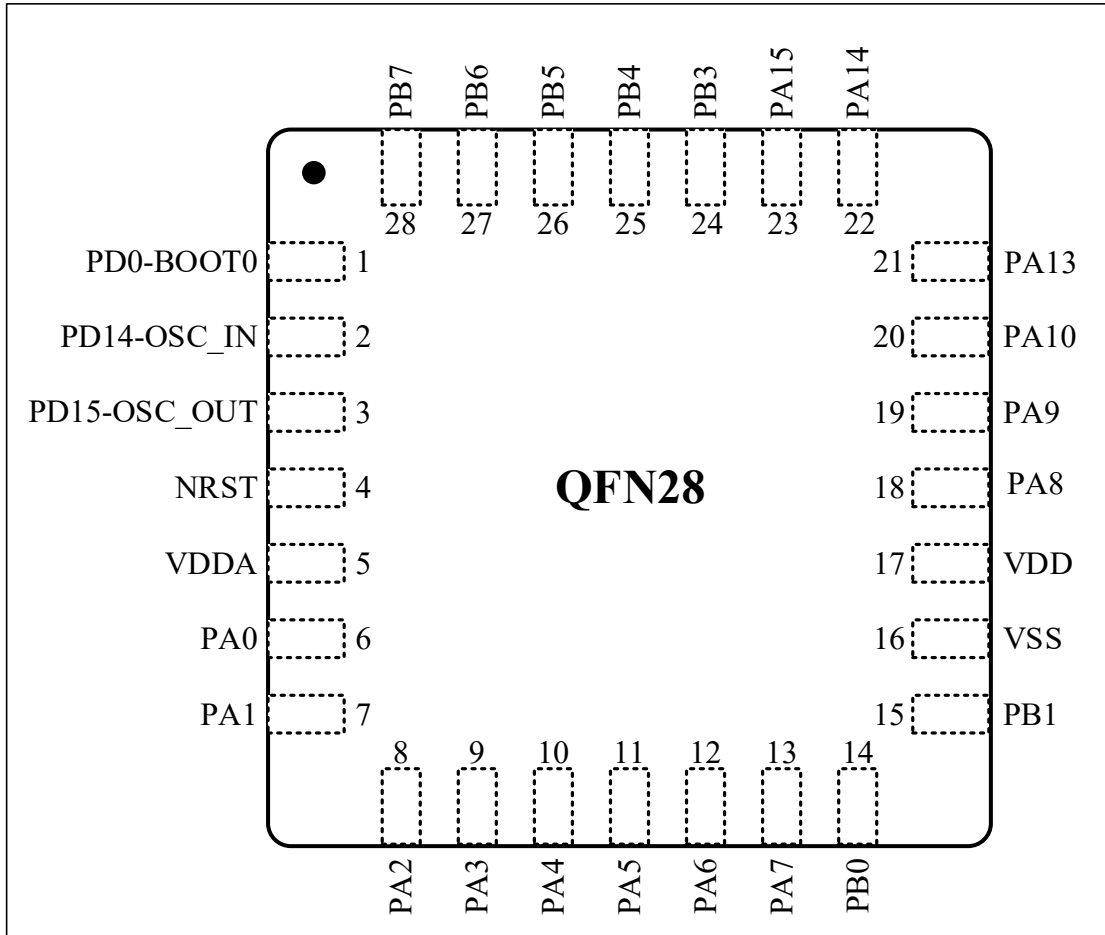
The device has an embedded ARM SWJ-DP interface, which is a combination of JTAG and serial single-wire debugging interface, can achieve serial single-line debugging interface or JTAG interface connection. The JTMS and JTCK signals of JTAG share pins with SWDIO and SWCLK respectively, and a special signal sequence on the JTMS pin is used to switch between JTAG-DP and SW-DP.

### 3 Pinouts And Pin Description

#### 3.1 Pinouts

##### 3.1.1 QFN28

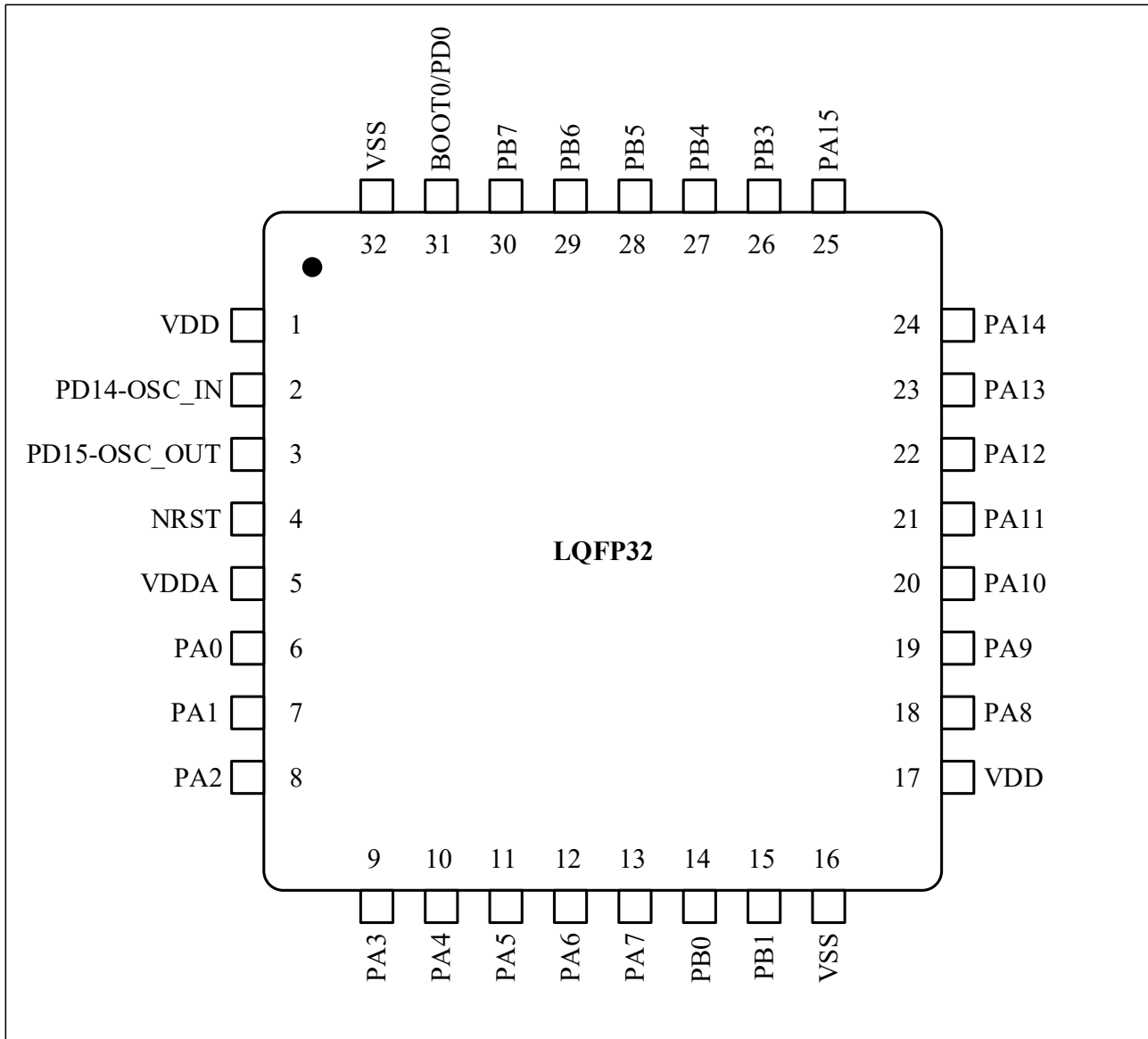
Figure 3-1. N32G435 Series QFN28 Pinout





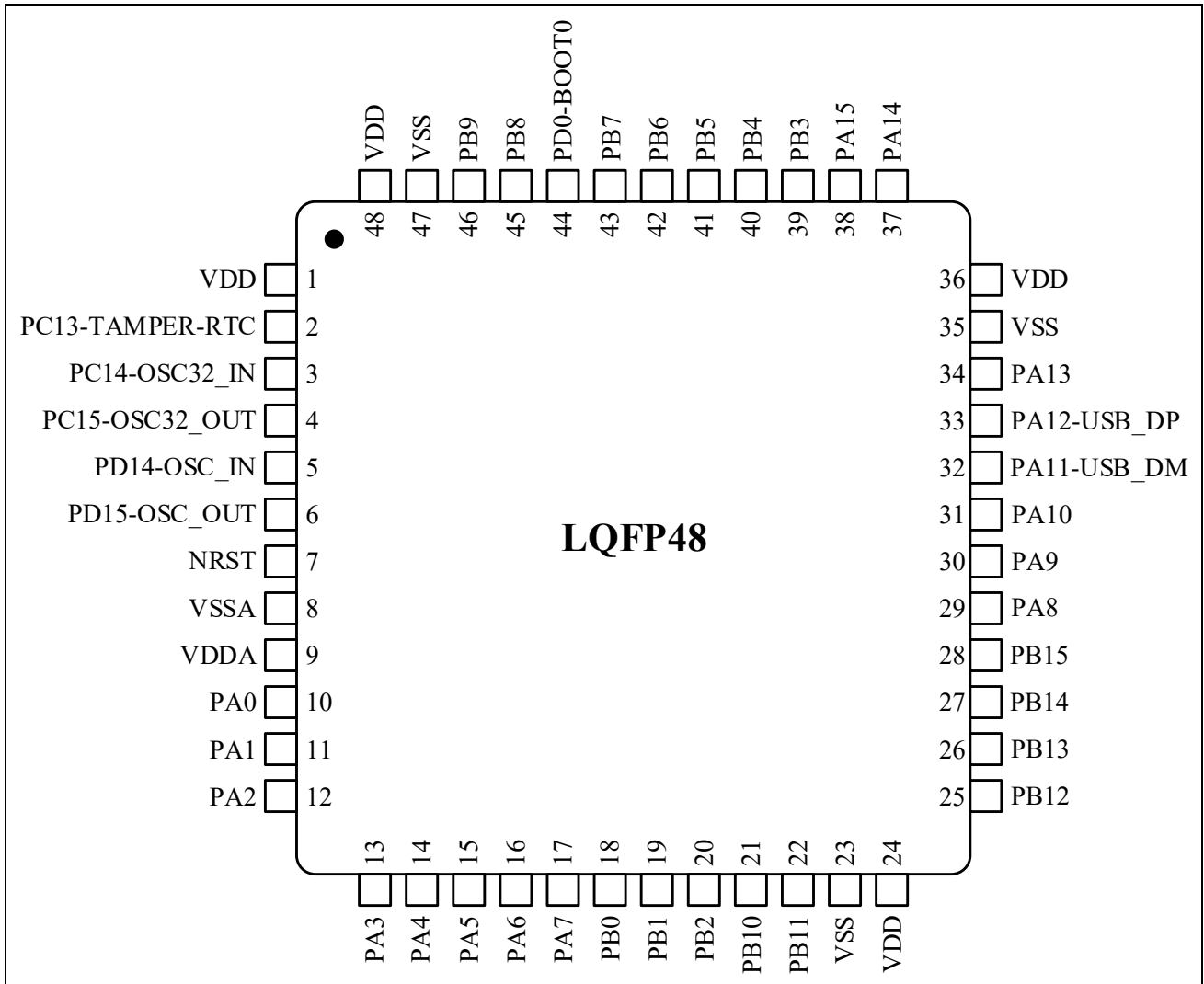
3.1.2 LQFP32

Figure 3-2 N32G435 Series LQFP32 Pinout



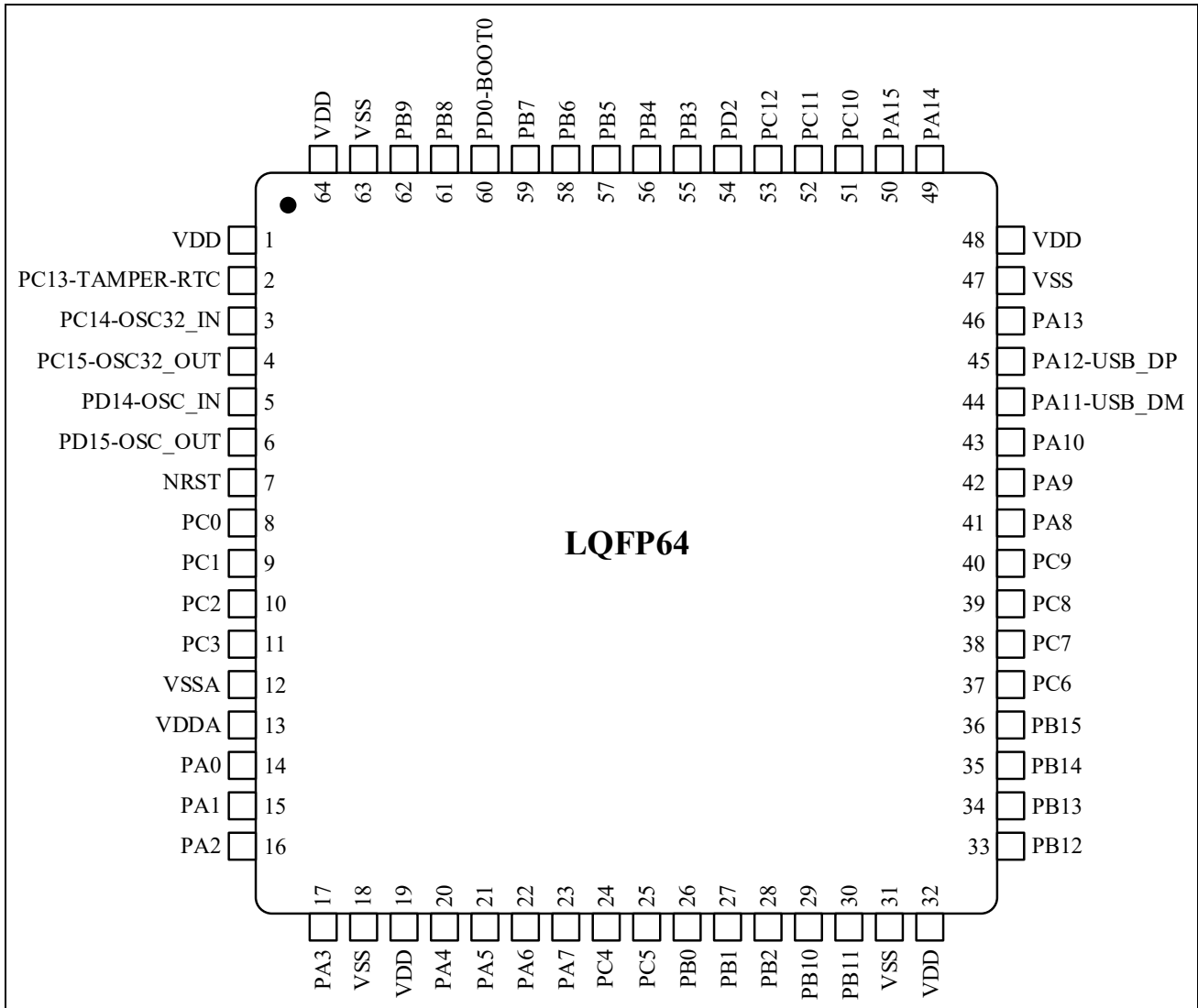
3.1.3 LQFP48

Figure 3-3 N32G435 Series LQFP48 Pinout



3.1.4 LQFP64

Figure 3-4 N32G435 Series LQFP64 Pinout



### 3.2 Pin Description

Table 3-1 Pin Description

QFN28	LQFP32	LQFP48	LQFP64	Pin Name (after reset)	Type <sup>(1)</sup>	I/O structure <sup>(2)</sup>	Fail-safe <sup>(4)</sup> Support	Alternate Function <sup>(3)</sup>	Optional Function
-	1	1	1	VDD	S	-	-	-	-
-	-	2	2	PC13-TAMPER- RTC <sup>(9)</sup>	I/O	TTa	Yes	TIM1_CH1N EVENTOUT	TAMP1-RTC RTC_OUT WKUP2
-	-	3	3	PC14- OSC32_IN	I/O	TTa	Yes	-	OSC32_IN
-	-	4	4	PC15- OSC32_OUT	I/O	TTa	Yes	-	OSC32_OUT
2	2	5	5	PD14-OSC_IN	I/O	TTa	No	USART2_TX I2C2_SDA TIM1_CH3N	OSC_IN
3	3	6	6	PD15-OSC_OUT	I/O	TTa	No	USART2_RX I2C2_SCL	OSC_OUT
4	4	7	7	NRST	I	-	-	-	-
-	-	-	8	PC0 <sup>(9)</sup>	I/O	TTa	Yes	I2C1_SCL LPTIM_IN1 EVENTOUT	ADC_IN11 <sup>(6)</sup>
-	-	-	9	PC1 <sup>(9)</sup>	I/O	TTa	Yes	LPTIM_OUT I2C1_SDA EVENTOUT	ADC_IN12 <sup>(6)</sup>
-	-	-	10	PC2 <sup>(9)</sup>	I/O	TTa	Yes	EVENTOUT LPTIM_IN2	ADC_IN13 <sup>(6)</sup>
-	-	-	11	PC3 <sup>(9)</sup>	I/O	TTa	Yes	LPTIM_ETR EVENTOUT	ADC_IN14 <sup>(6)</sup>
-	-	8	12	VSSA/VREF-	S	-	-	-	-
5	5	9	13	VDDA/VREF+	S	-	-	-	-
6	6	10	14	PA0	I/O	TTa	Yes	USART2_CTS LPUART_RX TIM2_CH1 TIMER2_ETR TIM5_CH1 TIM8_ETR SPI1_MISO I2S1_MCK EVENTOUT COMP1_OUT	ADC_IN1 <sup>(5)</sup> COMP1_INM COMP1_INP WKUP1 TAMP2-RTC
7	7	11	15	PA1	I/O	TTa	Yes	USART2_RTS LPUART_TX TIM5_CH2 TIM2_CH2 EVENTOUT	ADC_IN2 <sup>(5)</sup> COMP1_INP OPAMP1_VINP
8	8	12	16	PA2	I/O	TTa	Yes	USART2_TX TIM5_CH3 TIM2_CH3 I2C2_SDA COMP2_OUT EVENTOUT	ADC_IN3 <sup>(5)</sup> OPAMP1_VOUT COMP1_INP <sup>(8)</sup> COMP2_INM
9	9	13	17	PA3	I/O	TTa	Yes	USART2_RX LPUART_RX TIM5_CH4 I2C2_SCL EVENTOUT	ADC_IN4 <sup>(5)</sup> COMP1_INP <sup>(7)</sup> COMP2_INP OPAMP1_VINM
-	-	-	18	VSS	S	-	-	-	-
-	-	-	19	VDD	S	-	-	-	-
10	10	14	20	PA4	I/O	TTa	No	USART2_CK	DAC_OUT

QFN28	LQFP32	LQFP48	LQFP64	Pin Name (after reset)	Type <sup>(1)</sup>	I/O structure <sup>(2)</sup>	Fail-safe <sup>(4)</sup> Support	Alternate Function <sup>(3)</sup>	Optional Function
								LPUART_TX I2C1_SCL SPI1_NSS I2S1_WS USART1_TX EVENTOUT	ADC_IN5 <sup>(5)</sup> COMP1_INM COMP2_INM OPAMP1_VINP OPAMP2_VINP
11	11	15	21	PA5	I/O	TTa	Yes	SPI1_SCK I2C1_SDA I2S1_CK USART1_RX EVENTOUT	ADC_IN6 <sup>(6)</sup> COMP1_INM COMP2_INM OPAMP1_VINP OPAMP2_VINM
12	12	16	22	PA6	I/O	TTa	Yes	LPUART_CTS SPI1_MISO I2S1_MCK TIM8_BKIN TIM3_CH1 TIM1_BKIN COMP2_OUT EVENTOUT	ADC_IN7 <sup>(6)</sup> OPAMP2_VOUT COMP2_INM COMP2_INP
13	13	17	23	PA7	I/O	TTa	Yes	SPI1_MOSI I2S1_SD TIM1_CH1N TIM8_CH1N TIM3_CH2 COMP2_OUT EVENTOUT	ADC_IN8 <sup>(6)</sup> COMP2_INP OPAMP1_VINP OPAMP2_VINP
-	-	-	24	PC4 <sup>(9)</sup>	I/O	TTa	Yes	LPUART_TX I2C1_SCL EVENTOUT	ADC_IN15 <sup>(6)</sup>
-	-	-	25	PC5	I/O	TTa	Yes	LPUART_RX I2C1_SDA EVENTOUT	ADC_IN16 <sup>(6)</sup> OPAMP1_VINM OPAMP2_VINM
14	14	18	26	PB0	I/O	TTa	Yes	TIM1_CH2N TIM3_CH3 TIM8_CH2N UART4_TX EVENTOUT	ADC_IN9 <sup>(6)</sup> OPAMP2_VINM
15	14	19	27	PB1 <sup>(9)</sup>	I/O	TTa	Yes	LPUART_RTS TIM1_CH3N TIM3_CH4 TIM8_CH3N UART4_RX EVENTOUT	ADC_IN10 <sup>(6)</sup>
-	-	20	28	PB2	I/O	TTa	No	LPTIM_OUT TIM9_ETR EVENTOUT	-
-	-	21	29	PB10	I/O	TTa	Yes	USART3_TX LPUART_TX I2C2_SCL TIM2_CH3 EVENTOUT	COMP1_INP
-	-	22	30	PB11 <sup>(9)</sup>	I/O	TTa	Yes	USART3_RX LPUART_RX I2C2_SDA TIM2_CH4 EVENTOUT	-
16	16	23	31	VSS	S	-	-	-	-
17	-	24	32	VDD	S	-	-	-	-

QFN28	LQFP32	LQFP48	LQFP64	Pin Name (after reset)	Type <sup>(1)</sup>	I/O structure <sup>(2)</sup>	Fail-safe <sup>(4)</sup> Support	Alternate Function <sup>(3)</sup>	Optional Function
-	-	25	33	PB12 <sup>(9)</sup>	I/O	TTa	Yes	SPI2_NSS I2S2_WS I2C2_SMBA USART3_CK TIM1_BKIN LPUART_RTS TIM9_CH1 EVENTOUT	-
-	-	26	34	PB13 <sup>(9)</sup>	I/O	TTa	Yes	SPI2_SCK I2S2_CK USART3_CTS I2C2_SCL LPUART_CTS TIM1_CH1N TIM9_CH2 EVENTOUT	-
-	-	27	35	PB14	I/O	TTa	Yes	SPI2_MISO I2S2_MCK TIM1_CH2N USART3_RTS I2C2_SDA LPUART_RTS TIM9_CH3 EVENTOUT UART4_TX	OPAMP2_VINP
-	-	28	36	PB15 <sup>(9)</sup>	I/O	TTa	Yes	UART4_RX SPI2_MOSI I2S2_SD TIM1_CH3N TIM9_CH4 EVENTOUT	-
-	-	-	37	PC6 <sup>(9)</sup>	I/O	TTa	Yes	SPI2_NSS I2S2_WS TIM8_CH1 TIM3_CH1 EVENTOUT	-
-	-	-	38	PC7 <sup>(9)</sup>	I/O	TTa	Yes	SPI2_SCK I2S2_CK TIM3_CH2 TIM8_CH2 EVENTOUT	-
-	-	-	39	PC8 <sup>(9)</sup>	I/O	TTa	Yes	SPI2_MISO I2S2_MCK TIM8_CH3 TIM3_CH3	-
-	-	-	40	PC9 <sup>(9)</sup>	I/O	TTa	Yes	SPI2_MOSI I2S2_SD TIM3_CH4 TIM8_CH4 EVENTOUT	-
18	18	29	41	PA8 <sup>(9)</sup>	I/O	TTa	Yes	USART1_CK I2C2_SMBA TIM1_CH1 I2C2_SDA SPI1_NSS I2S1_WS MCO EVENTOUT	WKUP0 TAMP3-RTC
19	19	30	42	PA9 <sup>(9)</sup>	I/O	TTa	Yes	USART1_TX I2C2_SCL TIM1_CH2	-

QFN28	LQFP32	LQFP48	LQFP64	Pin Name (after reset)	Type <sup>(1)</sup>	I/O structure <sup>(2)</sup>	Fail-safe <sup>(4)</sup> Support	Alternate Function <sup>(3)</sup>	Optional Function
								EVENTOUT	
20	20	31	43	PA10 <sup>(9)</sup>	I/O	TTa	Yes	USART1_RX I2C2_SDA SPI1_SCK SPI2_SCK I2S1_CK I2S2_CK TIM1_CH3 EVENTOUT	-
-	21	32	44	PA11	I/O	TTa	No	USART1_CTS SPI2_MISO I2S2_MCK CAN_RX TIM1_CH4 COMP1_OUT EVENTOUT	USB_DM COMP2_INP
-	22	33	45	PA12	I/O	TTa	No	USART1_RTS SPI2_MOSI I2S2_SD CAN_TX TIM1_ETR COMP2_OUT EVENTOUT	USB_DP COMP1_INP
21	23	34	46	PA13 <sup>(9)</sup>	I/O	TTa	Yes	SWDIO-JTMS SPI2_NSS I2S2_WS EVENTOUT	-
-	-	35	47	VSS	S	-	-	-	-
-	-	36	48	VDD	S	-	-	-	-
22	24	37	49	PA14 <sup>(9)</sup>	I/O	TTa	Yes	SWCLK-JTCK USART2_CK I2C1_SDA COMP2_OUT	-
23	25	38	50	PA15	I/O	TTa	Yes	JTDI USART2_CTS I2C1_SCL SPI2_NSS I2S2_WS TIM2_CH1 TIM2_ETR EVENTOUT	COMP2_INP
-	-	-	51	PC10 <sup>(9)</sup>	I/O	TTa	Yes	USART3_TX UART4_TX LPUART_TX EVENTOUT	-
-	-	-	52	PC11 <sup>(9)</sup>	I/O	TTa	Yes	USART3_RX UART4_RX LPUART_RX EVENTOUT	-
-	-	-	53	PC12 <sup>(9)</sup>	I/O	TTa	Yes	USART3_CK UART5_TX EVENTOUT	-
-	-	-	54	PD2 <sup>(9)</sup>	I/O	TTa	Yes	TIM3_ETR UART5_RX LPUART_RTS EVENTOUT	-
24	26	39	55	PB3	I/O	TTa	Yes	USART2_RTS SPI1_SCK I2S1_CK	COMP1_INP COMP2_INM

QFN28	LQFP32	LQFP48	LQFP64	Pin Name (after reset)	Type <sup>(1)</sup>	I/O structure <sup>(2)</sup>	Fail-safe <sup>(4)</sup> Support	Alternate Function <sup>(3)</sup>	Optional Function
								TIM2_CH2 JTDO-TRACESWO EVENTOUT	
25	27	40	56	PB4	I/O	TTa	Yes	USART2_TX SPI1_MISO I2S1_MCK TIM3_CH1 UART5_TX EVENTOUT NJTRST	COMP1_INP
26	28	41	57	PB5	I/O	TTa	Yes	USART2_RX I2C1_SMBA SPI1_MOSI I2S1_SD TIM3_CH2 UART5_RX LPTIM_IN1 EVENTOUT	COMP1_INM
27	29	42	58	PB6 <sup>(9)</sup>	I/O	TTa	Yes	USART1_TX LPUART_TX I2C1_SCL SPI1_NSS I2S1_WS TIM1_CH2N TIM4_CH1 SPI2_SCK I2S2_CK LPTIM_ETR COMP1_OUT EVENTOUT	
28	30	43	59	PB7	I/O	TTa	Yes	USART1_RX LPUART_RX I2C1_SDA TIM4_CH2 EVENTOUT LPTIM_IN2 PVD_IN	COMP2_INP
1	31	44	60	BOOT0/PD0 <sup>(9)</sup>	I/O	TTa	Yes	TRACECK	-
-		45	61	PB8 <sup>(9)</sup>	I/O	TTa	Yes	I2C1_SCL CAN_RX TIM4_CH3 USART1_TX UART5_TX COMP1_OUT EVENTOUT	
-		46	62	PB9 <sup>(9)</sup>	I/O	TTa	Yes	I2C1_SDA CAN_TX TIM4_CH4 UART5_RX COMP2_OUT EVENTOUT	
-	32	47	63	VSS	S	-	-	-	-
-	-	48	64	VDD	S	-	-	-	-

Notes:

<sup>(1)</sup> I = input, O = output, S = power supply.

<sup>(2)</sup> TTa: 3.3V Standard IO.



- (3) This alternate function can be configured by the software to other pins (if the corresponding package model has such pins). For detailed information, please refer to the alternate function I/O chapter and debug setting chapter of the N32G435xx user reference manual.*
- (4) Fail-safe indicates that when the chip has no power input, a high input level is added to the IO. The high input level does not flood into the chip, resulting in a certain voltage on the power supply and current consumption.*
- (5) The corresponding ADC channel is a fast channel and supports a maximum sampling rate of 5.14MSPS (12Bit).*
- (6) The corresponding ADC channel is a slow channel and supports a maximum sampling rate of 4.23MSPS (12Bit).*
- (7) Only applicable if the second character in the 8-bit code in the last line of the chip silk screen is not "B".*
- (8) Only applicable if the second character in the 8-bit code in the last line of the chip silk screen is "B".*
- (9) No more than 5V can be tolerated on the pin.*

## 4 Electrical Characteristics

### 4.1 Parameter Conditions

All voltages are based on  $V_{SS}$  unless otherwise specified.

#### 4.1.1 Minimum and Maximum Values

Unless otherwise specified, all minimums and maximums will be guaranteed under the worst ambient temperature, supply voltage and clock frequency conditions by performing tests on 100% of the product on the production line at ambient temperatures  $T_A = 25^\circ\text{C}$ .

Note at the bottom of each form that data obtained through comprehensive evaluation, design simulation and/or process characteristics will not be tested on the production; Base on comprehensive evaluation, the minimum and maximum values are obtained by taking the average of the samples tested and adding or subtracting three times the standard distribution (mean  $\pm 3\Sigma$ ).

#### 4.1.2 Typical Values

Unless otherwise specified, typical data are based on  $T_A = 25^\circ\text{C}$  and  $V_{DD} = 3.3\text{V}$ . These data are for design guidance only and not tested.

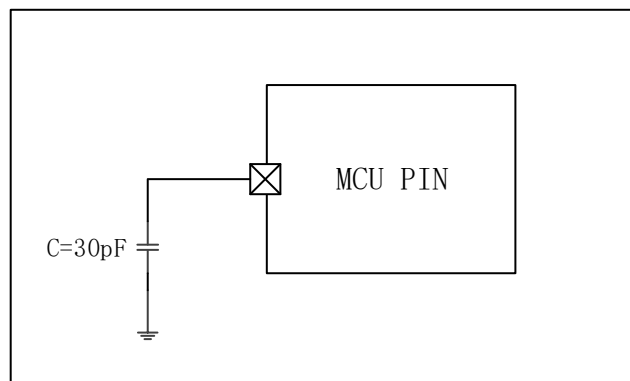
#### 4.1.3 Typical Curves

Unless otherwise specified, typical curves are for design guidance only and not tested.

#### 4.1.4 Loading Capacitors

The load conditions for measuring pin parameters are shown in the figure below:

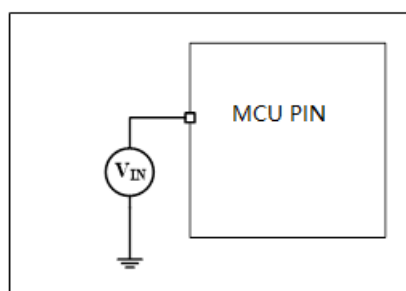
**Figure 4-1 Load Conditions Of Pins**



#### 4.1.5 Pin Input Voltage

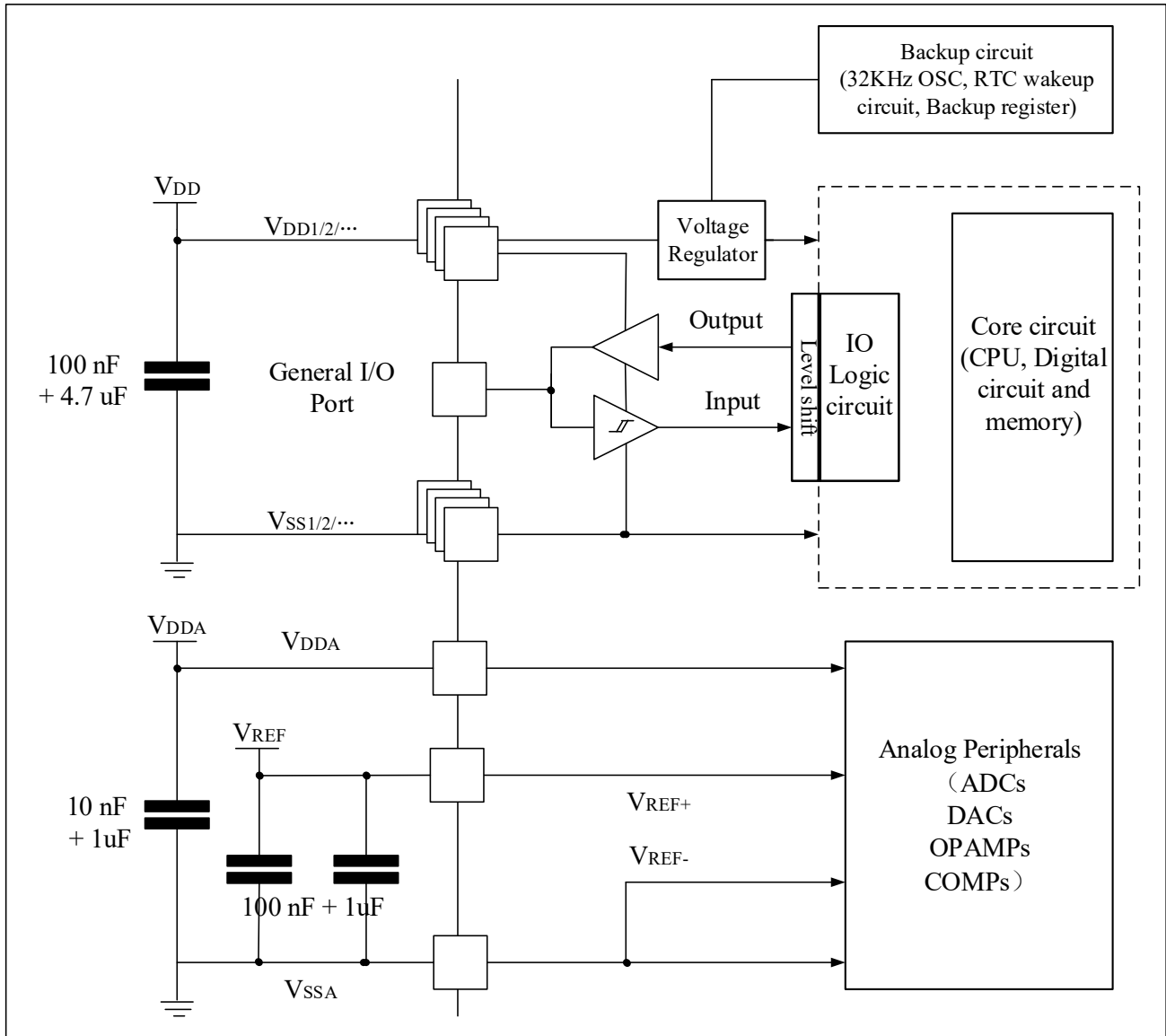
The measurement of the input voltage on the pin is shown in the figure below:

**Figure 4-2 Pin Input Voltage**



4.1.6 Power Supply Scheme

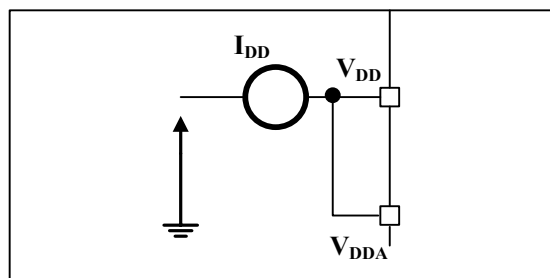
Figure 4-3 Power Supply Scheme



Note: Please refer to the hardware design guide for the capacitor connection method.  $V_{REF}$  is only available for ADC and DAC.

4.1.7 Current Consumption Measurement

Figure 4-4 Current Consumption Measurement Scheme



## 4.2 Absolute Maximum Rating

The load applied to the device may permanently damage the device if it exceeds the values given in the Absolute maximum rating list (**Table 4-1**, **Table 4-2**, **Table 4-3**). The maximum load that can be sustained is only given here, and it does not mean that the functional operation of the device under such conditions is correct. The reliability of the device will be affected when the device works for a long time under the maximum condition.

**Table 4-1 Voltage Characteristics**

Symbol	Describe	Min	Max	Unit
$V_{DD} - V_{SS}$	External main supply voltage (including $V_{DDA}$ and $V_{DD}$ ) <sup>(1)</sup>	-0.3	4.0	V
$V_{IN}$	Input voltage on other pins <sup>(2)</sup>	$V_{SS} - 0.3$	$V_{DD} + 0.3$	
$ \Delta V_{DDx} $	Voltage difference between different supply pins	-	50	mV
$ V_{SSx} - V_{SS} $	Voltage difference between different ground pins	-	50	
$V_{ESD(HBM)}$	ESD Electrostatic discharge voltage (human body model)	See section 4.3.11		-

Notes:

<sup>(1)</sup>All power ( $V_{DD}$ ,  $V_{DDA}$ ) and ground ( $V_{SS}$ ,  $V_{SSA}$ ) pins must always be connected to the external power supply system within permissible limits.

<sup>(2)</sup> $V_{IN}$  shall not exceed its maximum value. Refer to **Table 4-2** for current characteristics.

**Table 4-2 Current Characteristics**

Symbol	Describe	Max <sup>(1)</sup>	Unit
$I_{VDD}$	Total current through $V_{DD}/V_{DDA}$ power line (supply current) <sup>(1)(4)</sup>	200	mA
$I_{VSS}$	Total current through $V_{SS}$ ground line (outflow current) <sup>(1)(4)</sup>	200	
$I_{IO}$	Output current sunk by I/O and control pins	12	
	Output current source by I/O and control pins	- 12	
$I_{INJ(PIN)}^{(2)(3)}$	Injection current on NRST pin	-5/0	
	Injection current on other pins	+/-5	

Notes:

<sup>(1)</sup>All power ( $V_{DD}$ ,  $V_{DDA}$ ) and ground ( $V_{SS}$ ,  $V_{SSA}$ ) pins must always be connected to the external power supply system within permissible limits.

<sup>(2)</sup>When  $V_{IN} > V_{DD}$ , there is a forward injection current; when  $V_{IN} < V_{SS}$ , there is a reverse injection current.  $I_{INJ(PIN)}$  should not exceed its maximum value. Refer to **Table 4-1** for voltage characteristics.

<sup>(3)</sup>Reverse injection current can interfere with the analog performance of the device. See section 4.3.19.

<sup>(4)</sup>When the maximum current occurs, the maximum allowable voltage drop of  $V_{DD}$  is  $0.1V_{DD}$ .

**Table 4-3 Temperature Characteristics**

Symbol	Describe	Value	Unit
$T_{STG}$	Storage temperature range	- 40 ~ + 125	°C
$T_J$	Maximum junction temperature	125	°C

## 4.3 Operating Conditions

### 4.3.1 General Operating Conditions

**Table 4-4 General Operating Conditions**

Symbol	Parameter	Condition	Min	Max	Unit
f <sub>HCLK</sub>	Internal AHB clock frequency	-	0	108	MHz
f <sub>PCLK1</sub>	Internal APB1 clock frequency	-	0	27	
f <sub>PCLK2</sub>	Internal APB2 clock frequency	-	0	54	
V <sub>DD</sub>	Standard operating voltage	-	1.8	3.6	V
V <sub>DDA</sub>	Analog operating of working voltage	Must be the same potential as V <sub>DD</sub> <sup>(1)</sup>	1.8	3.6	V
T <sub>A</sub>	Ambient temperature (temperature number 7)	-	- 40	105	°C
T <sub>J</sub>	Junction temperature range	7 suffix version	- 40	125	°C

Note: <sup>(1)</sup> It is recommended that the same power supply be used to power the V<sub>DD</sub> and V<sub>DDA</sub>. During power-on and normal operation, a maximum of 300mV difference is allowed between the V<sub>DD</sub> and V<sub>DDA</sub>.

### 4.3.2 Operating Conditions at Power-on and Power-off

The parameters given in the following table are based on the ambient temperatures listed in **Table 4-4**.

**Table 4-5 Operating Conditions At Power-On And Power-Off**

Symbol	Parameter	Condition	Min	Max	Unit
t <sub>VDD</sub>	V <sub>DD</sub> rise time rate	Supply voltage goes from 0 to V <sub>DD</sub>	20	∞	μs/V
	V <sub>DD</sub> fall time rate	Supply voltage drops from V <sub>DD</sub> to 0	80	∞	

### 4.3.3 Embedded Reset and Power Control Module Characteristics

The parameters given in the following table are based on the ambient temperature and V<sub>DD</sub> supply voltage listed in **Table 4-4**.

**Table 4-6 Features Of Embedded Reset And Power Control Modules**

Symbol	Parameter	Conditions	Min	Typ	Max	Unit
V <sub>PVD</sub>	Programmable voltage detector level selection	PVD0_rising	2.1	2.15	2.2	V
		PVD0_falling	2	2.05	2.1	V
		PVD1_rising	2.25	2.3	2.35	V
		PVD1_falling	2.15	2.2	2.25	V
		PVD2_rising	2.4	2.45	2.5	V
		PVD2_falling	2.3	2.35	2.4	V
		PVD3_rising	2.55	2.6	2.65	V
		PVD3_falling	2.45	2.5	2.55	V
		PVD4_rising	2.7	2.75	2.8	V
		PVD4_falling	2.6	2.65	2.7	V
		PVD5_rising	2.85	2.9	2.95	V
		PVD5_falling	2.75	2.8	2.85	V
		PVD6_rising	2.95	3	3.05	V

Symbol	Parameter	Conditions	Min	Typ	Max	Unit
		PVD6_falling	2.85	2.9	2.95	V
V <sub>PVDhyst</sub> <sup>(1)</sup>	PVD hysteresis	-	-	100	-	mV
V <sub>BOR</sub>	VDD Power on/off Reset threshold	POR0	1.6	1.64	1.68	V
		PDR0	1.58	1.62	1.66	V
		POR1	2.05	2.1	2.15	V
		PDR1	1.95	2	2.05	V
		POR2	2.25	2.3	2.35	V
		PDR2	2.15	2.2	2.25	V
		POR3	2.55	2.6	2.65	V
		PDR3	2.45	2.5	2.55	V
		POR4	2.85	2.9	2.95	V
PDR4	2.75	2.8	2.85	V		
TRSTEMPO <sup>(1)</sup>	Reset duration	-	-	0.15	-	ms

Note: <sup>(1)</sup>Guaranteed by design, not tested in production.

### 4.3.4 Internal Reference Voltage

The parameters given in the following table are based on the ambient temperature and V<sub>DD</sub> supply voltage listed in Table 4-4.

Table 4-7 Internal Reference Voltage

Symbol	Parameter	Conditions	Min	Typ	Max	Unit
V <sub>REFINT</sub>	Internal reference voltage	-40 °C < T <sub>A</sub> < +105 °C	1.164	1.20	1.236	V
T <sub>S_vrefint</sub> <sup>(1)</sup>	The sampling time of the ADC when reading the internal reference voltage	-	-	5.1	10 <sup>(2)</sup>	μs

Notes:

<sup>(1)</sup> The shortest sampling time is obtained through multiple loops in the application.

<sup>(2)</sup> Guaranteed by design, not tested in production.

### 4.3.5 Power Supply Current Characteristics

The current consumption is a combination of several parameters and factors, including operating voltage, ambient temperature, load of I/O pins, software configuration of the product, operating frequency, toggle rate of I/O pins, program location in memory, and code executed.

The measurement method of current consumption is described in Figure 4-4.

All the current consumption measurements given in this section are while executing a reduced set of code.

#### 4.3.5.1 Maximum Current Consumption

The device is under the following conditions:

- All I/O pins are in input mode and are connected to a static level -- V<sub>DD</sub> or V<sub>SS</sub> (no load).
- All peripherals are disabled except otherwise noted.
- The access time of the flash memory is adjusted to the fastest operating frequency (0 waiting period from 0 to 32MHz, 1 waiting period from 32 to 64MHz, 2 waiting periods from 64 to 96MHz, 3 waiting periods from 96 to 108MHz).
- Instruction prefetch is enabled (note: this parameter must be set before setting the clock and bus divider).
- When the peripheral is enable: f<sub>PCLK1</sub> = f<sub>HCLK</sub>/4, f<sub>PCLK2</sub> = f<sub>HCLK</sub>/2.

The parameters given in **Table 4-8** and **Table 4-9** are based on tests at the ambient temperature and  $V_{DD}$  supply voltage listed in **Table 4-4**.

**Table 4-8 Maximum Current Consumption in Operating Mode with Code Executing from Internal Flash**

Symbol	Parameter	Condition	$f_{HCLK}$	Typ <sup>(1)</sup>	Unit
				$V_{DD}=3.3V, T_A = 105^{\circ}C$	
$I_{DD}^{(2)}$	Supply current in operation mode	External clock, enable all peripherals	108MHz	13	mA
			72MHz	9.5	
			36MHz	6.4	
		External clock, disable all peripherals	108MHz	9.6	
			72MHz	7.4	
			36MHz	5.2	
$I_{DD}^{(3)}$	Supply current in operation mode	Internal clock, enable all peripherals	64MHz	6.0	mA
			32MHz	3.8	
		Internal clock, disable all peripherals	64MHz	4.0	
			32MHz	2.5	

Notes:

<sup>(1)</sup> Based on comprehensive evaluation, not tested in production.

<sup>(2)</sup> In Rang0 mode ( $MR = 1.1V$ ), enable PLL when  $f_{HCLK} > 8MHz$ .

<sup>(3)</sup> In Rang1 mode ( $MR = 1.0V$ ), enable PLL when  $f_{HCLK} > 8MHz$ .

**Table 4-9 Maximum Current Consumption In Sleep Mode with Code Executing in Internal Flash**

Symbol	Parameter	Conditions	$f_{HCLK}$	Typ <sup>(1)</sup>	Unit
				$V_{DD} = 3.3V, T_A = 105^{\circ}C$	
$I_{DD}^{(2)}$	Supply current in sleep mode	External clock, enable all peripherals	108MHz	8.9	mA
			72MHz	7.0	
			36MHz	5.2	
		External clock, disable all peripherals	108MHz	5.7	
			72MHz	5.0	
			36MHz	4.0	
$I_{DD}^{(3)}$	Supply current in sleep mode	Internal clock, enable all peripherals	64MHz	4.2	mA
			32MHz	2.5	
		Internal clock, disable all peripherals	64MHz	2.2	
			32MHz	1.6	

Notes:

<sup>(1)</sup> Based on comprehensive evaluation result, not tested in production.

<sup>(2)</sup> In Rang0 mode ( $MR = 1.1V$ ), enable PLL when  $f_{HCLK} > 8MHz$ .

<sup>(3)</sup> In Rang1 mode ( $MR = 1.0V$ ), enable PLL when  $f_{HCLK} > 8MHz$ .

### 4.3.5.2 Typical Current Consumption

MCU is under the following conditions:

- All I/O pins are in input mode and are connected to a static level --  $V_{DD}$  or  $V_{SS}$  (no load).
- All peripherals are disable unless otherwise noted.
- The access time of the flash memory is adjusted to the fastest operating frequency (0 waiting periods from 0 to 32MHz, 1 waiting period from 32 to 64MHz, 2 waiting periods from 64MHz to 96 MHz, and 3 waiting periods from 96 to 108MHz).
- Ambient temperature and  $V_{DD}$  supply voltage conditions are listed in **Table 4-4**.
- Instruction prefetch is enabled (note: this parameter must be set before setting the clock and bus divider). When the peripheral is turned on:  $f_{PCLK1} = f_{HCLK} / 4$ ,  $f_{PCLK2} = f_{HCLK} / 2$ ,  $f_{ADCCLK} = f_{PCLK2} / 4$ .

**Table 4-10 Typical Current Consumption In Operating Mode with Code Executing from Internal Flash**

Symbol	Parameter	Conditions	$f_{HCLK}$	Typ <sup>(1)</sup>		Unit
				Enable all peripherals	Disable all peripherals	
$I_{DD}^{(2)}$	Supply current in operation mode	External clock	108MHz	11.5	8.4	mA
			72MHz	8.4	6.3	
			36MHz	5.3	4.3	
$I_{DD}^{(3)}$	Supply current in operation mode	Internal clock	64MHz	5.9	3.7	mA
			32MHz	3.3	2.3	

Notes:

<sup>(1)</sup>Typical values are measured at  $T_A = 25\text{ }^\circ\text{C}$  and  $V_{DD} = 3.3V$ .

<sup>(2)</sup>In Rang0 mode ( $MR = 1.1V$ ), enable PLL when  $f_{HCLK} > 8MHz$ .

<sup>(3)</sup>In Rang1 mode ( $MR = 1.0V$ ), enable PLL when  $f_{HCLK} > 8MHz$ .

**Table 4-11 Typical Current Consumption In Sleep Mode with Code Executing from Internal Flash**

Symbol	Parameter	Condition	$f_{HCLK}$	Typ <sup>(1)</sup>		Unit
				Enable all peripherals <sup>(2)</sup>	Disable all peripherals	
$I_{DD}^{(3)}$	Supply current in sleep mode	External clock	108MHz	7.8	4.7	mA
			72MHz	6.0	3.9	
			36MHz	4.1	3	
$I_{DD}^{(4)}$	Supply current in sleep mode	Internal clock	64MHz	3.8	2.0	mA
			32MHz	2.3	1.4	

Notes:

<sup>(1)</sup> Typical values are measured at  $T_A = 25\text{ }^\circ\text{C}$  and  $V_{DD} = 3.3V$ .

<sup>(2)</sup> ADC additional 0.2mA current consumption is added. In the application environment, this part of the current is increased only when the ADC is turned on (set  $ADC\_CTRL2.ON$  bit).

<sup>(3)</sup> In Rang0 mode ( $MR = 1.1V$ ), enable PLL when  $f_{HCLK} > 8MHz$ .

<sup>(4)</sup> In Rang1 mode ( $MR = 1.0V$ ), enable PLL when  $f_{HCLK} > 8MHz$ .

### 4.3.5.3 Low Power Mode Current Consumption

The device is under the following conditions:

- All I/O pins are in input mode and are connected to a static level of  $-V_{DD}$  or  $V_{SS}$  (no load).



- All peripherals are off disabled otherwise noted.

**Table 4-12 Typical And Maximum Current Consumption In Shutdown and Standby Mode**

Symbol	Parameter	Condition	Typ <sup>(1)</sup>		Unit
			V <sub>DD</sub> = 3.3 V T <sub>A</sub> = 25 °C	V <sub>DD</sub> = 3.3 V T <sub>A</sub> = 105 °C	
I <sub>DD_STOP2</sub>	Supply current in Stop mode 2 (STOP2)	The external low-speed clock is on, the RTC is running, SRAM2 is on, all I/O states are on, and the independent watchdog is off	6 <sup>(1)</sup>	27 <sup>(1)</sup>	μA
I <sub>DD_STANDBY</sub>	Supply current in STANDBY mode	Low speed internal RC oscillator and independent watchdog are on	2.6 <sup>(1)</sup>	7.6 <sup>(1)</sup>	
		The low speed internal RC oscillator is on and the independent watchdog is off	2.5 <sup>(1)</sup>	7.5 <sup>(1)</sup>	
		The low speed internal RC oscillator and independent watchdog are closed, and the low speed oscillator and RTC are closed	2.4 <sup>(1)</sup>	7.3 <sup>(1)</sup>	

Note: <sup>(1)</sup> Based on comprehensive evaluation result, not tested in production.

### 4.3.6 External Clock Source Characteristics

#### 4.3.6.1 High-Speed External Clock Source (HSE)

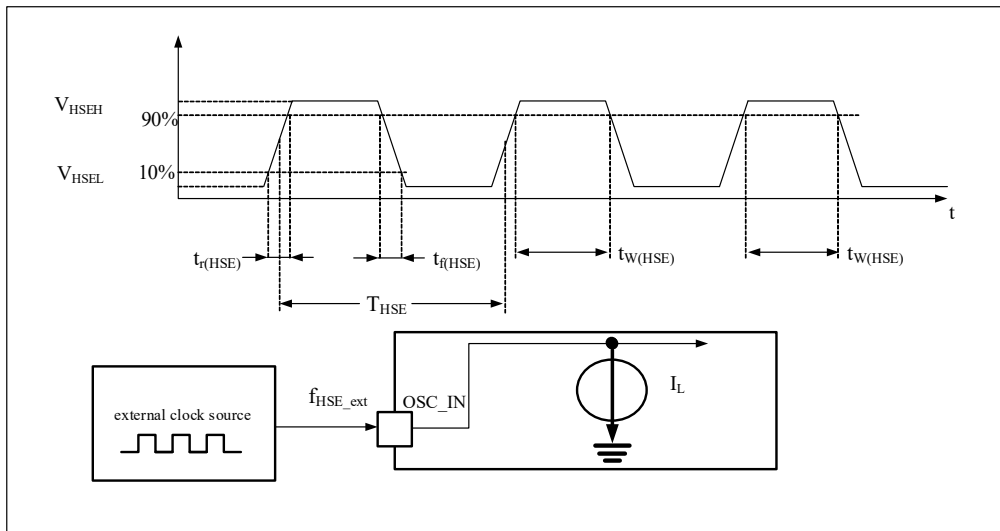
The characteristic parameters given in the following table are measured using a high-speed external clock source, and the ambient temperature and supply voltage meet the conditions specified in **Table 4-4**.

**Table 4-13 High-Speed External User Clock Features (Bypass Mode)**

Symbol	Parameter	Conditions	Min	Typ	Max	Unit	
f <sub>HSE_ext</sub>	User external clock frequency <sup>(1)</sup>	-	1	8	32	MHz	
V <sub>HSEH</sub>	OSC_IN Input pin high level voltage		0.8 V <sub>DD</sub>	-	V <sub>DD</sub>		V
V <sub>HSEL</sub>	OSC_IN Input pin low level voltage		V <sub>SS</sub>	-	0.3 V <sub>DD</sub>		
t <sub>w(HSE)</sub>	Time when OSC_IN is high or low <sup>(1)</sup>		16	-	-	ns	
t <sub>r(HSE)</sub> t <sub>f(HSE)</sub>	OSC_IN rise or fall time <sup>(1)</sup>		-	-	20		
DuCy <sub>(HSE)</sub>	Duty cycle		-	45	-	55	%
I <sub>L</sub>	OSC_IN Input leakage current	V <sub>SS</sub> ≤ V <sub>IN</sub> ≤ V <sub>DD</sub>	-	-	±1	μA	

Note: <sup>(1)</sup> Guaranteed by design, not tested in production.

Figure 4-5 AC Timing Diagram Of An External High-Speed Clock Source



4.3.6.2 Low-Speed External Clock Source (LSE)

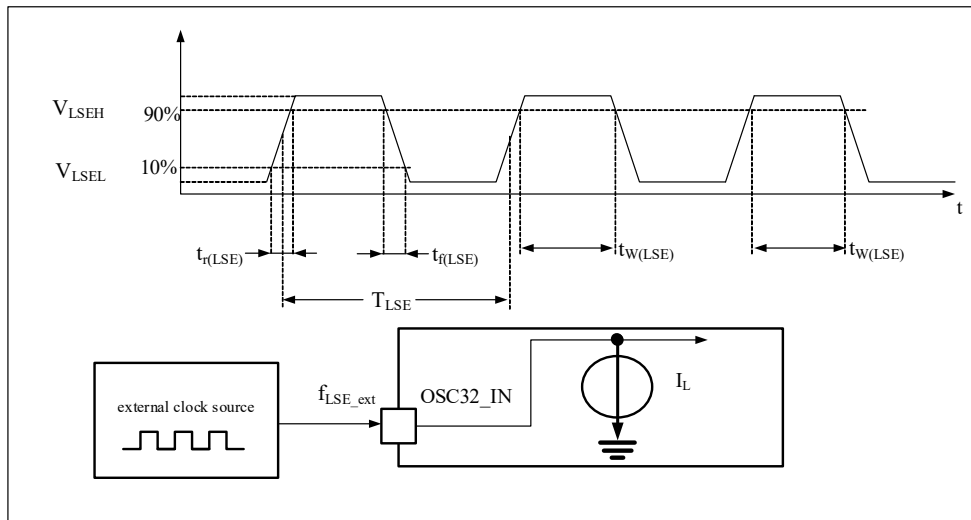
The characteristic parameters given in the following table are measured using a low-speed external clock source, and the ambient temperature and supply voltage meet the conditions specified in Table 4-4.

Table 4-14 Features Of A Low-Speed External User Clock (Bypass Mode)

Symbol	Parameter	Conditions	Min	Typ	Max	Unit
$f_{LSE\_ext}$	User external clock frequency <sup>(1)</sup>	-	0	32.768	1000	KHz
$V_{LSEH}$	OSC32_IN Input pin high level voltage		$0.7 V_{DD}$	-	$V_{DD}$	V
$V_{LSEL}$	OSC32_IN Input pin low level voltage		$V_{SS}$	-	200	mV
$t_{w(LSE)}$	OSC32_IN High or low time <sup>(1)</sup>		450	-	-	ns
$t_{r(LSE)}$ $t_{f(LSE)}$	OSC32_IN Rise or fall time <sup>(1)</sup>		-	-	50	
$DuCy_{(LSE)}$	Duty ratio		-	30	-	70
$I_L$	OSC32_IN Input leakage current	$V_{SS} \leq V_{IN} \leq V_{DD}$	-	-	$\pm 1$	$\mu A$

Note: <sup>(1)</sup>Guaranteed by design, not tested in production.

Figure 4-6 AC Timing Diagram Of An External Low Speed Clock Source



High-speed external clock generated using a crystal/ceramic resonator

High speed external clocks (HSE) can be generated using an oscillator consisting of a 4~32MHz crystal/ceramic resonator. The information presented in this section is based on a comprehensive feature evaluation using typical external components listed in the table below. In applications, the resonator and load capacitance must be as close to the oscillator pins as possible to reduce output distortion and stabilization time at startup. For detailed crystal resonator parameters (frequency, package, accuracy, etc.), please consult the appropriate manufacturer. (The crystal resonator mentioned here is usually referred to as passive crystal oscillator)

Table 4-15 HSE 4~32MHz Oscillator Characteristics <sup>(1) (2)</sup>

Symbol	Parameter	Conditions	Min	Typ	Max	Unit
$f_{OSC\_IN}$	Oscillator frequency	-	4	8	32	MHz
$R_F$	Feedback resistance	-	-	160	-	K $\Omega$
$i_2$	HSE drive current	$V_{DD} = 3.3V, V_{IN} = V_{SS}$ 30 pf load	-	1.5	-	mA
$g_m$	Transconductance of the oscillator	Start	-	10	-	mA/V
$t_{SU(HSE)}^{(3)}$	Startup time (8M crystal)	$V_{DD}$ is stabilized	-	3	-	ms

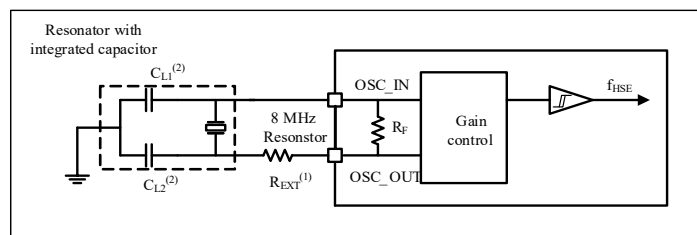
Notes:

<sup>(1)</sup>The characteristic parameters of the resonator are given by the crystal/ceramic resonator manufacturer.

<sup>(2)</sup>Guaranteed by characterization results, not tested in production.

<sup>(3)</sup> $t_{SU(HSE)}$  is the start time, from the time when HSE is enabled by the software to the time when a stable 8MHz oscillation is obtained. This value is measured on a standard crystal resonator and can vary widely depending on the crystal manufacturer.

Figure 4-7 Typical Application Using 8MHz Crystal



Notes:

<sup>(1)</sup>The  $R_{EXT}$  value depends on the properties of the crystal. Typical values are 5 to 6 times  $R_S$ .

<sup>(2)</sup>For  $C_{L1}$  and  $C_{L2}$ , it is recommended to use high quality ceramic dielectric vessels, and to select crystals or resonators that meet the requirements. Usually  $C_{L1}$  and  $C_{L2}$  have the same parameters. Crystal manufacturers usually give parameters for load capacitance as serial combinations of  $C_{L1}$  and  $C_{L2}$ . When selecting  $C_{L1}$  and  $C_{L2}$ , the capacitance of PCB and MCU pins should be taken into account.

Low-speed external clock generated by a crystal/ceramic resonator

The low speed external clock (LSE) can be generated using an oscillator consisting of a 32.768 kHz crystal/ceramic resonator. The information presented in this section is based on a comprehensive feature evaluation using typical external components listed in **Table 4-16**. In applications, the resonator and load capacitance must be as close to the oscillator pins as possible to reduce output distortion and stabilization time at startup. For detailed crystal resonator parameters (frequency, package, accuracy, etc.), please consult the appropriate manufacturer. (The crystal resonator mentioned here is usually referred to as passive crystal oscillator)

Note: For  $C_{L1}$  and  $C_{L2}$ , it is recommended to use high quality ceramic dielectric containers, and to select crystals or resonators that meet the requirements. Usually  $C_{L1}$  and  $C_{L2}$  have the same parameters. Crystal manufacturers usually give parameters for load capacitance as serial combinations of  $C_{L1}$  and  $C_{L2}$ .

Load capacitance  $C_L$  is calculated by the following formula:  $C_L = C_{L1} \times C_{L2} / (C_{L1} + C_{L2}) + C_{stray}$ , where  $C_{stray}$  is the capacitance of the pin and the PCB or PCB-related capacitance.

For example: If a resonator with load capacitance  $C_L = 6pF$  is selected and  $C_{stray} = 2pF$ , then  $C_{L1} = C_{L2} = 8pF$ .

**Table 4-16 LSE Oscillator Characteristics ( $f_{LSE} = 32.768kHz$ ) <sup>(1)</sup> <sup>(2)</sup> <sup>(4)</sup> <sup>(5)</sup>**

Symbol	Parameter	Conditions	Min	Typ	Max	Unit
$R_F$	Feedback resistance	-	-	5	-	$M\Omega$
$g_m$	Transconductance of the oscillator	-	-	15	-	$\mu A/V$
$t_{SU(LSE)}^{(3)}$	Startup time	$V_{DD}$ is stabilized	-	2	-	s

Notes:

<sup>(1)</sup>Guaranteed by design, not tested in production.

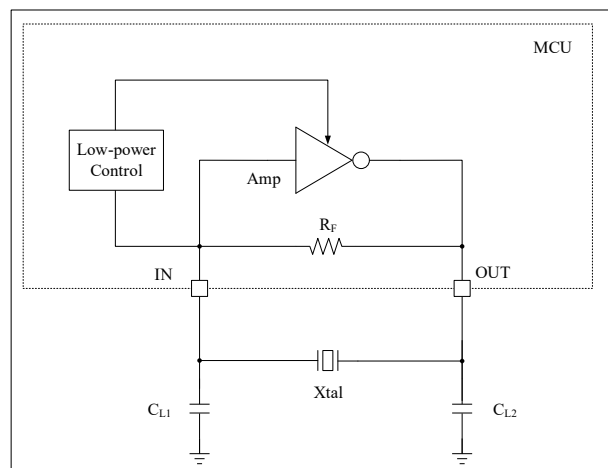
<sup>(2)</sup>See the cautions section at the top of this form.

<sup>(3)</sup> $t_{SU(LSE)}$  is the starting time, which is the period from the LSE enabled by the software to the stable 32.768kHz oscillation. This value is measured on a standard crystal resonator and can vary widely depending on the crystal manufacturer.

<sup>(4)</sup>Please refer to the LSE crystal selection guide.

<sup>(5)</sup>In order to ensure the stability of crystal operation, do not turn the adjacent pins when crystal is working.

**Figure 4-8 Typical Application Of 32.768kHz Crystal**



### 4.3.7 Internal Clock Source Characteristics

The characteristic parameters given in the following table were measured using ambient temperature and supply voltage in accordance with **Table 4-4**.

#### 4.3.7.1 Multi-Speed Internal (MSI) RC Oscillator

**Table 4-17 MSI Oscillator Characteristics <sup>(1)</sup>**

Symbol	Parameter	Condition	Min	Typ	Max	Unit
f <sub>MSI</sub>	Range 0	MSI Frequency after Factory calibration, done at V <sub>DD</sub> = 3.3V and T <sub>A</sub> = 27 °C	-	100	-	KHz
	Range 1		-	200	-	KHz
	Range 2		-	400	-	KHz
	Range 3		-	800	-	KHz
	Range 4		-	1	-	MHz
	Range 5		-	2	-	MHz
	Range 6		3.96 <sup>(4)</sup>	4 <sup>(4)</sup>	4.1 <sup>(4)</sup>	MHz
Δ <sub>TEMP</sub> (MSI) <sup>(2)</sup>	MSI oscillator frequency drift over temperature	T <sub>A</sub> = 0 to 85 °C	-	±1%@4M ±1.2%@100k	-	%
		T <sub>A</sub> = -40 to 105 °C	-	±2%@4M ±3%@100k	-	%
Δ <sub>VDD</sub> (MSI) <sup>(2)</sup>	MSI oscillator frequency drift over V <sub>DD</sub> (reference is 3 V)	Range 0, V = 1.8V <sub>DD</sub> to 3.6V	-	0.5 / - 1.5	-	%
		Range 6, V = 1.8V <sub>DD</sub> to 3.6V	-	0.5 / - 5	-	%
t <sub>SU</sub> (MSI) <sup>(3)</sup>	MSI oscillator start-up time	Range 0 /100k	-	20	-	μs
		Range 1 /200k	-	12	-	μs
		Range 2 /400k	-	8	-	μs
		Range 3 /800k	-	6	-	μs
		Range 4 /1M	-	10	-	μs
		Range 5 /2M	-	7	-	μs
		Range 6 /4M	-	6	-	μs
I <sub>DD</sub> (MSI) <sup>(3)</sup>	MSI oscillator power consumption	Range 0 /100k	-	1.0	-	μA
		Range 1 /200k	-	1.2	-	μA
		Range 2 /400k	-	1.8	-	μA
		Range 3 /800k	-	3.2	-	μA
		Range 4 /1M	-	6	-	μA
		Range 5 /2M	-	9	-	μA
		Range 6 /4M	-	16	-	μA

Notes:

<sup>(1)</sup>V<sub>DD</sub> = 3.3V, T<sub>A</sub> = -40~105 °C unless otherwise specified.

<sup>(2)</sup>This deviation range is the deviation of the oscillator after calibration;

<sup>(3)</sup>Guaranteed by design, not tested in production.

<sup>(4)</sup>After Reflow, the frequency will drift, and the maximum drift value is about 2.0%.

#### 4.3.7.2 High Speed Internal (HSI) RC Oscillator

**Table 4-18 HSI Oscillator Characteristics <sup>(1) (2)</sup>**

Symbol	Parameter	Condition	Min	Typ	Max	Unit
f <sub>HSI</sub>	frequency	V <sub>DD</sub> =3.3V, T <sub>A</sub> = 25 °C, after calibration	15.84 <sup>(3)</sup>	16 <sup>(3)</sup>	16.16 <sup>(3)</sup>	MHz

Symbol	Parameter	Condition	Min	Typ	Max	Unit
ACC <sub>HSI</sub>	Temperature drift of HSI oscillator	V <sub>DD</sub> =3.3V, T <sub>A</sub> = -40~105°C, temperature drift	-2.5	-	2.5	%
		V <sub>DD</sub> =3.3V, T <sub>A</sub> = -10~85°C, temperature drift	-1.5 <sup>(4)</sup>	-	1.0 <sup>(4)</sup>	%
		V <sub>DD</sub> =3.3V, T <sub>A</sub> = 0~70°C, temperature drift	-1.2 <sup>(4)</sup>	-	0.7 <sup>(4)</sup>	%
t <sub>SU(HSI)</sub>	HSI oscillator start time	-	-	5.0	μs	
I <sub>DD(HSI)</sub>	HSI oscillator power consumption	-	-	80 <sup>(5)</sup>	100 <sup>(5)</sup>	μA
			-	135 <sup>(4)</sup>	160 <sup>(4)</sup>	

Notes:

<sup>(1)</sup> V<sub>DD</sub> = 3.3V, T<sub>A</sub> = -40~105 °C unless otherwise specified.

<sup>(2)</sup> Guaranteed by design, not tested in production.

<sup>(3)</sup> After Reflow, the frequency will drift, and the maximum drift value is about +1.6%.

<sup>(4)</sup> Applicable to version F and later versions.

<sup>(5)</sup> Applicable to the previous version of version F.

#### 4.3.7.3 Low Speed Internal (LSI) RC Oscillator

Table 4-19 LSI Oscillator Characteristics <sup>(1)</sup>

Symbol	Parameter	Condition	Min	Typ	Max	Unit
f <sub>LSI</sub> <sup>(2)</sup>	Output frequency	25°C calibration, V <sub>DD</sub> = 3.3V	38	40	42	KHz
		V <sub>DD</sub> = 1.8 V to 3.6 V, T <sub>A</sub> = - 40 ~ 105 °C	30	40	60	KHz
t <sub>SU(LSI)</sub> <sup>(2)</sup>	LSI oscillator startup time	-	-	40	80	μs
I <sub>DD(LSI)</sub> <sup>(2)</sup>	LSI oscillator power consumption	-	-	0.12	-	μA

Notes:

<sup>(1)</sup> V<sub>DD</sub> = 3.3V, T<sub>A</sub> = -40~105 °C unless otherwise specified.

<sup>(2)</sup> Guaranteed by characterization results, not tested in production.

#### 4.3.8 Time to wake up from low power mode

The wake-up time listed in **Table 4-20** is measured during the wake-up phase of an 8MHz HSI RC oscillator. The clock source used when waking up depends on the current operating mode:

- STOP2 or STANDBY mode: clock source is RC oscillator
- SLEEP mode: The clock source is the clock used to enter sleep mode

All times were measured using ambient temperature and supply voltage in accordance with **Table 4-4**.

**Table 4-20 Wake Time In Low Power Mode**

Symbol	Parameter	Typ	Unit
twUSLEEP <sup>(1)</sup>	Wake up from SLEEP mode	10	HCLK <sup>(2)</sup>
twUSLEEP <sup>(1)</sup>	Wake up from Low-Power SLEEP mode	10	HCLK <sup>(2)</sup>
twULPRUN <sup>(1)</sup>	Wake up from Low-Power RUN mode	5.5	μs <sup>(2)</sup>
twUSTOP2 <sup>(1)</sup>	Wake up from STOP2 mode	12	μs <sup>(2)</sup>
twUSTDBY <sup>(1)</sup>	Wake up from STANDBY mode	50	

Notes:

- <sup>(1)</sup> The wake up time is measured from the start of the wake up event until the first instruction is read by the user program.  
<sup>(2)</sup> The wake up time is obtained when MSI = 4MHz. If MSI is in other gears, the wake up time will be increased.

### 4.3.9 PLL Characteristics

The parameters listed in **Table 4-21** are measured when the ambient temperature and power supply voltage meet the conditions in **Table 4-4**

**Table 4-21 PLL Features**

Symbol	Parameter	Value			Unit
		Min	Typ	Max <sup>(1)</sup>	
f <sub>PLL_IN</sub>	PLL PFD input clock <sup>(2)</sup>	4	8	32	MHz
	PLL Input clock duty cycle	40	50	60	%
f <sub>PLL_OUT</sub>	PLL output clock <sup>(2)</sup>	32	-	108	MHz
t <sub>LOCK</sub>	PLL Ready indicates signal output time <sup>(3)</sup>	-	-	150	μs
Jitter	RMS cycle-to-cycle jitter @108MHz <sup>(1)</sup>	-	6	-	ps
I <sub>pll</sub>	Operating Current of PLL @108MHz VCO frequency. <sup>(1)</sup>	-	448	-	μA

Notes:

- <sup>(1)</sup>Based on comprehensive evaluation, not tested in production.  
<sup>(2)</sup>The correct configuration coefficients need to be used so that the f<sub>PLL\_OUT</sub> is within the allowable range according to the PLL input clock frequency.  
<sup>(3)</sup>Guaranteed by design, not tested in production.

### 4.3.10 FLASH Memory Characteristics

Unless otherwise specified, all characteristic parameters are obtained at T<sub>A</sub> = -40~105°C.

**Table 4-22 Flash Memory Characteristics**

Symbol	Parameter	Condition	Min <sup>(1)</sup>	Typ <sup>(1)</sup>	Max <sup>(1)</sup>	Unit
t <sub>prog</sub>	32-bit programming time	T <sub>A</sub> = - 40 ~ 105 °C	-	100	-	μs
t <sub>ERASE</sub>	Page (2K bytes) erasure time	T <sub>A</sub> = - 40 ~ 105 °C	-	2	20	ms
t <sub>ME</sub>	Mass erase time	T <sub>A</sub> = - 40 ~ 105 °C	-	-	100	ms
I <sub>DD</sub>	The power supply current	Read mode, f <sub>HCLK</sub> = 108MHz, 3 waiting cycles, V <sub>DD</sub> = 3.3V	-	-	3.42	mA

Symbol	Parameter	Condition	Min <sup>(1)</sup>	Typ <sup>(1)</sup>	Max <sup>(1)</sup>	Unit
		Write mode, f <sub>HCLK</sub> = 108MHz, V <sub>DD</sub> = 3.3V	-	-	6.5	mA
		Erase mode, f <sub>HCLK</sub> = 108MHz, V <sub>DD</sub> = 3.3V	-	-	4.5	mA
		Power-down/stop mode, V <sub>DD</sub> = 3.3~3.6V	-	-	0.035	μA
V <sub>prog</sub>	Programming voltage	-	1.8	-	3.6	V

Note: <sup>(1)</sup> Guaranteed by design, not tested in production.

**Table 4-23 Flash Endurance And Data Retention Life**

Symbol	Parameter	Condition	Min <sup>(1)</sup>	Unit
N <sub>END</sub>	Endurance (note: erasure times)	T <sub>A</sub> = -40~105°C(7 suffix versions)	100	Keyle
t <sub>RET</sub>	Data retention period	10 keycle <sup>(2)</sup> at T <sub>A</sub> = 85°C	30	Years
		10 keycle <sup>(2)</sup> at T <sub>A</sub> = 105°C	20	
		10 keycle <sup>(2)</sup> at T <sub>A</sub> = 125°C	10	

Notes:

<sup>(1)</sup> Based on comprehensive evaluation, not tested in production.

<sup>(2)</sup> Cycling performed over the whole temperature range.

### 4.3.11 Absolute Maximum (Electrical Sensitivity)

Based on three different tests (ESD, LU), a specific measurement method is used to test the strength of the chip to determine its performance in terms of electrical sensitivity.

Electrostatic discharge (ESD)

Electrostatic discharge (a positive pulse followed by a negative pulse one second later) is applied to all pins of all samples, the size of which is related to the number of power pins on the chip (3 x (n+1) power pins). This test conforms to MIL-STD-883K Method 3015.9/ESDA/JEDEC JS-002-2018 standard.

**Table 4-24 Absolute Maximum ESD Value**

Symbol	Parameter	Condition	Type	Max <sup>(1)</sup>	Unit
V <sub>ESD(HBM)</sub>	Electrostatic discharge voltage (human body model)	T <sub>A</sub> = +25 °C, In accordance with MIL-STD-883K Method 3015.9	2	4000	V
V <sub>ESD(CDM)</sub>	Electrostatic discharge voltage (charging device model)	T <sub>A</sub> = +25 °C, In accordance with ESDA/JEDEC JS-002-2018	II	1000	

Note: <sup>(1)</sup> Based on comprehensive evaluation, not tested in production.

Static switch lock

To evaluate the locking performance, two complementary static locking tests were performed on six samples:

- Supply voltage exceeding limit for each power pin.
- Current is injected into each input, output, and configurable I/O pin.

This test conforms to JEDEC78E IC latch standard.



**Table 4-25 Electrical Sensitivity**

Symbol	Parameter	Condition	Type
LU	Static locking classes	$T_A^{(1)} = +85\text{ }^\circ\text{C}$ , in accordance with JEDEC78E	II class A
		$T_A^{(2)} = +25\text{ }^\circ\text{C}$ , in accordance with JEDEC78E	

Notes:

<sup>(1)</sup> Applicable to version F and later versions.

<sup>(2)</sup> Applicable to versions earlier than F.

### 4.3.12 I/O Port Characteristics

General input/output characteristics

Unless otherwise specified, the parameters listed in the following table are measured according to the conditions in **Table 4-4**. All I/O ports are CMOS and TTL compatible.

**Table 4-26 I/O Static Characteristics**

Symbol	Parameter	Condition	Min	Typ	Max	Unit
$V_{IL}$	Input low level voltage	TTL port	$V_{SS}$	-	0.8	V
$V_{IH}$	Input high level voltage		2	-	$V_{DD}$	
$V_{IL}$	Input low level voltage	CMOS port	$V_{SS}$	-	$0.35V_{DD}$	
$V_{IH}$	Input high level voltage		$0.65V_{DD}$	-	$V_{DD}$	
$V_{hys}$	Schmidt trigger voltage lag <sup>(1)(5)</sup>	-	0.1	-	-	V
$V_{hys}$	Schmidt trigger voltage lag <sup>(1)(6)</sup>	$V_{DD} = 3.3V/2.5V$	0.2	-	-	V
		$V_{DD} = 1.8V$	$0.1V_{DD}$	-	-	
$I_{lkg}$	Input leakage current <sup>(2)</sup>	$V_{DD} = \text{Maximum}$ $V_{PAD} = 0$ or $V_{PAD} = V_{DD}$	-1	-	+1	$\mu\text{A}$
$I_{lkg, fail-safe}$	Input leakage current <sup>(3)</sup>	$V_{DD} = 0$ , $V_{PAD} = 3.63V$ or $V_{DD} < V_{PAD}$	-1	-	+1	$\mu\text{A}$
$R_{PU}$	Weak pull-up equivalent resistance <sup>(4)</sup>	$V_{DD} = 3.3V$ , $V_{IN} = V_{SS}$	90	-	170(190 <sup>(7)</sup> )	$\text{K}\Omega$
		$V_{DD} = 2.5V$ , $V_{IN} = V_{SS}$	95	-	310	
		$V_{DD} = 1.8V$ , $V_{IN} = V_{SS}$	135	-	500	
$R_{PD}$	Weak pull-down equivalent resistance <sup>(4)</sup>	$V_{DD} = 3.3V$ , $V_{IN} = V_{DD}$	75(90 <sup>(7)</sup> )	-	235(200 <sup>(7)</sup> )	$\text{K}\Omega$
		$V_{DD} = 2.5V$ , $V_{IN} = V_{DD}$	85	-	315	
		$V_{DD} = 1.8V$ , $V_{IN} = V_{DD}$	120	-	495	
$C_{IO}$	Capacitance of I/O pins	-	-	5	-	pF

Notes:

<sup>(1)</sup> The hysteresis voltage of Schmitt trigger switching level. Based on comprehensive evaluation, not tested in production.

<sup>(2)</sup> The leakage current may be higher than the maximum if there is reverse current in adjacent pins.

<sup>(3)</sup> GPIO that does not support Fail-safe include PD14, PD15, PA11, PA12, PA4, and PB2

<sup>(4)</sup> Pull-up and pull-down resistors are implemented with a switchable PMOS/NMOS.

<sup>(5)</sup> Applicable to version F and later versions.

<sup>(6)</sup> Applicable to versions earlier than F.

<sup>(7)</sup> Applicable to version F and later versions.

All I/O ports are CMOS and TTL compatible (no software configuration required) and their features take into account most of the strict CMOS process or TTL parameters:

- For  $V_{IH}$ :  
If  $V_{DD}$  is between [1.8V ~ 3.08V]; Uses CMOS feature but includes TTL.  
If  $V_{DD}$  is between [3.08V ~ 3.60V]; Uses TTL feature but includes CMOS.
- For  $V_{IL}$ :  
If  $V_{DD}$  is between [1.8V ~ 2.28V]; Uses TTL feature but includes CMOS.  
If  $V_{DD}$  is between [2.28V ~ 3.60V]; Uses CMOS feature but includes TTL.

### Output drive current

GPIO (universal input/output port) can absorb or output up to +/-12mA current. In the user application, the number of I/O pins must ensure that the drive current does not exceed the absolute maximum ratings given in Section 4.2.

### Output voltage

Unless otherwise specified, the parameters listed in **Table 4-28** were measured using ambient temperature and VDD supply voltage in accordance with **Table 4-4**. All I/O ports are CMOS and TTL compatible

**Table 4-27 IO Output Drive Capability Characteristics**

Drive class	$I_{OH}^{(1)}$ $V_{DD}=3.3V$	$I_{OL}^{(1)}$ $V_{DD}=3.3V$	$I_{OH}^{(1)}$ $V_{DD}=2.5V$	$I_{OL}^{(1)}$ $V_{DD}=2.5V$	$I_{OH}^{(1)}$ $V_{DD}=1.8V$	$I_{OL}^{(1)}$ $V_{DD}=1.8V$	Unit
2	-2	2	-1.5	1.5	-1.2	1.2	mA
4	-4	4	-3	3	-2.5	2.5	mA
8	-8	8	-7	7	-5	5	mA
12	-12	12	-11	11	-7.5	7.5	mA

Note: <sup>(1)</sup> Guaranteed by design, not tested in production.

**Table 4-28 Output Voltage Characteristics**

Symbol	Parameter	Condition	Min	Max	Unit
$V_{OL}^{(1)}$	Output low level	$V_{DD} = 3.3 V$ , $I_{OL}^{(3)} = 2mA, 4mA, 8mA, \text{ and } 12mA$	$V_{SS}$	0.4	V
		$V_{DD} = 2.5 V$ , $I_{OL}^{(3)} = 1.5mA, 3mA, 7mA, \text{ and } 11mA$	$V_{SS}$	0.4	
		$V_{DD} = 1.8 V$ , $I_{OL}^{(3)} = 1.2mA, 2.5mA, 5mA, \text{ and } 7.5mA$	$V_{SS}$	$0.2 * V_{DD}$	
$V_{OH}^{(2)}$	Output high level	$V_{DD} = 3.3 V$ , $I_{OH}^{(3)} = -2mA, -4mA, -8mA, \text{ and } -12mA$	2.4	$V_{DD}$	V
		$V_{DD} = 2.5 V$ , $I_{OH}^{(3)} = -1.5mA, -3mA, -7mA, \text{ and } -11mA$	2	$V_{DD}$	
		$V_{DD} = 1.8 V$ , $I_{OH}^{(3)} = -1.2mA, -2.5mA, -5mA, \text{ and } -7.5mA$	$0.8 * V_{DD}$	$V_{DD}$	

Notes:

<sup>(1)</sup>The current  $I_{IO}$  absorbed by the chip must always follow the absolute maximum rating given in **Table 4-2**, and the sum of  $I_{IO}$  (all I/O pins and control pins) must not exceed  $I_{VSS}$ .

<sup>(2)</sup>The current  $I_{IO}$  output from the chip must always follow the absolute maximum rating given in **Table 4-2**, and the sum of  $I_{IO}$  (all I/O pins and control pins) must not exceed  $I_{VDD}$ .

<sup>(3)</sup>Actual drive capability see **Table 4-27**.

### Input/output AC characteristics

The definitions and values of the input and output AC characteristics are given in **Figure 4-9** and **Table 4-29** respectively.

Unless otherwise specified, the parameters listed in **Table 4-29** were measured using ambient temperature and supply voltage in accordance with **Table 4-4**.

Table 4-29 Input/Output AC Characteristics <sup>(1)</sup>

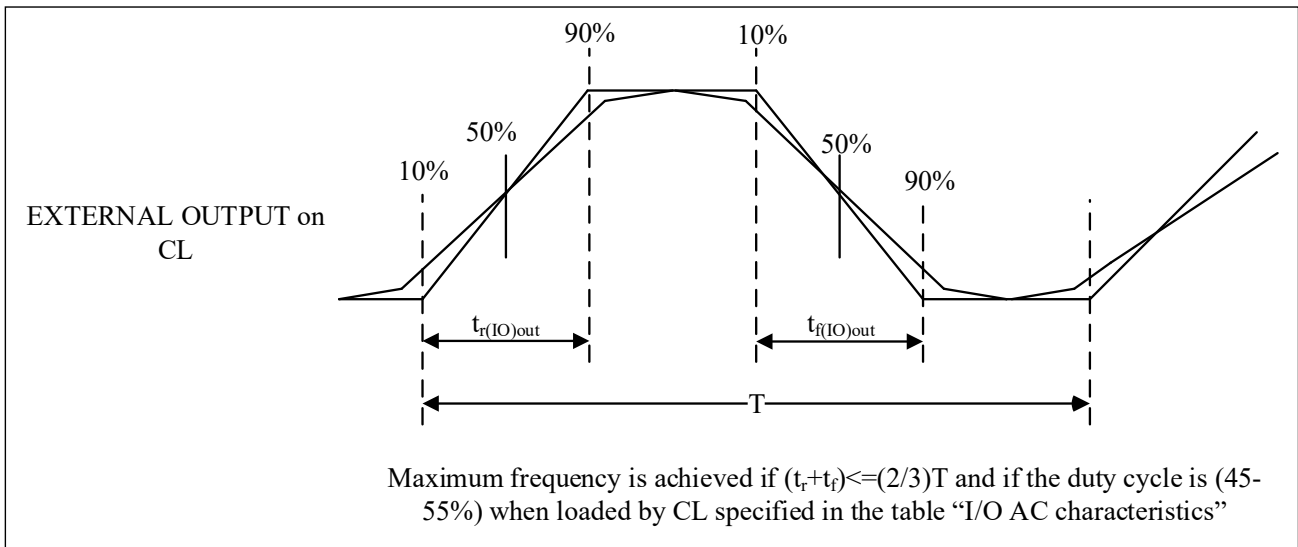
GPIOx_DS.DS y[1:0] Configuration	Symbol	Parameter	Condition	Min	Max	Unit
00 (2mA)	f <sub>max(IO)out</sub>	Maximum frequency <sup>(2)</sup>	C <sub>L</sub> = 5pF, V <sub>DD</sub> = 3.3V	-	75	MHz
			C <sub>L</sub> = 5pF, V <sub>DD</sub> = 2.5V	-	50	
			C <sub>L</sub> = 5pF, V <sub>DD</sub> = 1.8V	-	30	
	t <sub>(IO)out</sub>	Output delay (A to pad)	C <sub>L</sub> = 5pF, V <sub>DD</sub> = 3.3V	-	3.66	ns
			C <sub>L</sub> = 5pF, V <sub>DD</sub> = 2.5V	-	4.72	
			C <sub>L</sub> = 5pF, V <sub>DD</sub> = 1.8V	-	7.12	
t <sub>(IO)in</sub>	Input delay (pad to Y)	C <sub>L</sub> = 50fF, V <sub>DD</sub> = 2.97V, V <sub>DDD</sub> = 0.81V Input characteristics at 1.8V and 2.5V are derated	-	1.2	ns	
10 (4mA)	f <sub>max(IO)out</sub>	Maximum frequency <sup>(2)</sup>	C <sub>L</sub> = 10pF, V <sub>DD</sub> = 3.3V	-	90	MHz
			C <sub>L</sub> = 10pF, V <sub>DD</sub> = 2.5V		60	
			C <sub>L</sub> = 10pF, V <sub>DD</sub> = 1.8V		40	
	t <sub>(IO)out</sub>	The output delay (A to pad)	C <sub>L</sub> = 10pF, V <sub>DD</sub> = 3.3V	-	3.5	ns
			C <sub>L</sub> = 10pF, V <sub>DD</sub> = 2.5V		4.5	
			C <sub>L</sub> = 10pF, V <sub>DD</sub> = 1.8V		6.74	
t <sub>(IO)in</sub>	Input delay (pad to Y)	C <sub>L</sub> = 50fF, V <sub>DD</sub> = 2.97V, V <sub>DDD</sub> = 0.81V Input characteristics at 1.8V and 2.5V are derated	-	1.2		
01 (8mA)	f <sub>max(IO)out</sub>	Maximum frequency <sup>(2)</sup>	C <sub>L</sub> = 20pF, V <sub>DD</sub> = 3.3V	-	75	MHz
			C <sub>L</sub> = 20pF, V <sub>DD</sub> = 2.5V		50	
			C <sub>L</sub> = 20pF, V <sub>DD</sub> = 1.8V		30	
	t <sub>(IO)out</sub>	The output delay (A to pad)	C <sub>L</sub> = 20pF, V <sub>DD</sub> = 3.3V	-	3.42	ns
			C <sub>L</sub> = 20pF, V <sub>DD</sub> = 2.5V		4.73	
			C <sub>L</sub> = 20pF, V <sub>DD</sub> = 1.8V		6.53	
t <sub>(IO)in</sub>	Input delay (pad to Y)	C <sub>L</sub> = 50fF, V <sub>DD</sub> = 2.97V, V <sub>DDD</sub> = 0.81V Input characteristics at 1.8V and 2.5V are derated	-	1.2		
11 (12mA)	f <sub>max(IO)out</sub>	Maximum frequency <sup>(2)</sup>	C <sub>L</sub> = 30pF, V <sub>DD</sub> = 3.3V	-	75	MHz
			C <sub>L</sub> = 30pF, V <sub>DD</sub> = 2.5V		50	
			C <sub>L</sub> = 30pF, V <sub>DD</sub> = 1.8V		30	
	t <sub>(IO)out</sub>	The output delay (A to pad)	C <sub>L</sub> = 30pF, V <sub>DD</sub> = 3.3V	-	3.34	ns
			C <sub>L</sub> = 3pF, V <sub>DD</sub> = 2.5V		4.26	
			C <sub>L</sub> = 3pF, V <sub>DD</sub> = 1.8V		6.34	
t <sub>(IO)in</sub>	Input delay (pad to Y)	C <sub>L</sub> = 50fF, V <sub>DD</sub> = 2.97V, V <sub>DDD</sub> = 0.81V Input characteristics at 1.8V and 2.5V are derated	-	1.2		

Notes:

<sup>(1)</sup>The speed of the I/O port can be configured via GPIOx\_DS.DSy[1:0]. Refer to the N32G435 user manual for instructions on configuring registers for GPIO ports.

<sup>(2)</sup>The maximum frequency is defined in **Figure 4-9**.

Figure 4-9 Definition Of Input/Output AC Characteristics



### 4.3.13 NRST Pin Characteristics

The NRST pin input driver uses the CMOS process, which is connected to an unbreakable pull-up resistor,  $R_{PU}$  (see Table 4-26). Unless otherwise specified, the parameters listed in Table 4-30 were measured using ambient temperature and supply voltage in accordance with Table 4-4.

Table 4-30 NRST Pin Characteristics

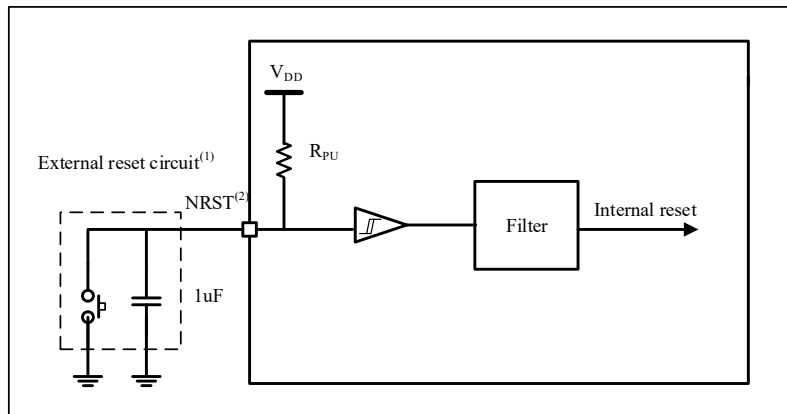
Symbol	Parameter	Condition	Min	Typ	Max	Unit
$V_{IL(NRST)}^{(1)}$	NRST input low level voltage	$V_{DD} = 3.3\text{ V}$	$V_{SS}$	-	0.8	V
		$V_{DD} = 1.8\text{ V}$	$V_{SS}$	-	$0.3 \cdot V_{DD}$	
$V_{IH(NRST)}^{(1)}$	NRST input high level voltage	$V_{DD} = 3.3\text{ V}$	2	-	$V_{DD}$	V
		$V_{DD} = 1.8\text{ V}$	$0.7 \cdot V_{DD}$	-	$V_{DD}$	
$V_{hys(NRST)}$	NRST Schmidt trigger voltage hysteresis	$V_{DD} = 3.3\text{ V}$	200	-	-	mV
		$V_{DD} = 1.8\text{ V}$	$0.1 \cdot V_{DD}$	-	-	V
$R_{PU}$	Weak pull-up equivalent resistance <sup>(2)</sup>	$V_{DD} = 3.3\text{ V}$	30	50	70	K $\Omega$
$V_{F(NRST)}^{(1)}$	NRST input filter pulse	-	-	-	100	ns
$V_{NF(NRST)}^{(1)}$	NRST input unfiltered pulse	-	300	-	-	ns

Notes:

<sup>(1)</sup> Guaranteed by design, not tested in production.

<sup>(2)</sup> The pull-up resistor is designed as a real resistor in series for a switchable PMOS implementation. The resistance of this PMON/NMOS switch is very small (about 10%).

Figure 4-10 Recommended NRST Pin Protection



Notes:

(1) Resetting the network is to prevent parasitic resets.

(2) The user must ensure that the NRST pin potential is below the maximum  $V_{IL(NRST)}$  listed in Table 4-30, otherwise the MCU cannot be reset.

### 4.3.14 Timer and Watchdog Characteristics

The parameters listed in Table 4-31, Table 4-32 and Table 4-33 are guaranteed by design.

See section 0 for details on the features of the I/O alternate function pins (output comparison, input capture, external clock, PWM output).

Table 4-31 TIM1/8 Characteristics

Symbol	Parameter	Condition	Min	Typ	Unit
$t_{res(TIM)}$	Timer time resolution	-	1	-	$t_{TIMCLK}$
		$f_{TIMCLK} = 108MHz$	9.259	-	ns
$f_{EXT}$	Timer CH1 to CH2 external clock frequency	-	0	$f_{TIMCLK}/2$	MHz
		$f_{TIMCLK} = 108MHz$	0	54	MHz
ResTIM	Timer resolution	-	-	16	bits
$t_{COUNTER}$	16 bit counter clock cycle when internal clock is selected	-	1	65536	$t_{TIMCLK}$
		$f_{TIMCLK} = 108MHz$	0.009259	606.814815	$\mu s$
$t_{MAX\_COUNT}$	Maximum count	-	-	65536x65536	$t_{TIMCLK}$
		$f_{TIMCLK} = 108MHz$	-	39.768	s

Table 4-32 TIM2/3/4/5/6/7/9 Characteristics

Symbol	Parameter	Condition	Min	Typ	Unit
$t_{res(TIM)}$	Timer time resolution	-	1	-	$t_{TIMCLK}$
		$f_{TIMCLK} = 54MHz$	18.519	-	ns
$f_{EXT}$	Timer CH1 to CH2 External clock frequency	-	0	$f_{TIMCLK}/2$	MHz
		$f_{TIMCLK} = 54MHz$	0	27	MHz
ResTIM	Timer resolution	-	-	16	bits
$t_{COUNTER}$	16 bit counter clock cycle when internal clock is selected	-	1	65536	$t_{TIMCLK}$
		$f_{TIMCLK} = 54MHz$	0.0185185	1213.62963	$\mu s$
$t_{MAX\_COUNT}$	Maximum count	-	-	65536x65536	$t_{TIMCLK}$
		$f_{TIMCLK} = 54MHz$	-	79.536	s

**Table 4-33 LPTIMER Characteristics**

Symbol	Parameter	Condition	Min	Typ	Unit
$t_{res(LPTIM)}$	Timer time resolution	-	1	-	$t_{LPTIMCLK}$
		$f_{LPTIMCLK} = 27\text{MHz}$	37.037	-	ns
$f_{EXT}$	IN2 to OUT external clock frequency	-	0	27	MHz
		$f_{LPTIMCLK} = 27\text{MHz}$	0	27	MHz
$ResLPTIM$	Timer resolution	-	-	16	bits
$t_{COUNTER}$	16 bit counter clock cycle when internal clock is selected	-	1	65536	$t_{LPTIMCLK}$
		$f_{LPTIMCLK} = 27\text{MHz}$	0.037037	2427.25926	$\mu\text{s}$
$t_{MAX\_COUNT}$	Maximum count	-	-	65536x65536	$t_{LPTIMCLK}$
		$f_{LPTIMCLK} = 27\text{MHz}$	-	159.073	s

**Table 4-34 IWDG Counting Maximum and Minimum Reset Time (LSI = 40kHz)**

Prescaler	IWDG_PREDIV.PD[2:0]	Min <sup>(1)</sup> IWDG_RELV.REL[11:0] = 0	Max <sup>(1)</sup> IWDG_RELV.REL[11:0] = 0xFFF	Unit
/4	000	0.1	409.6	ms
/8	001	0.2	819.2	
/16	010	0.4	1638.4	
/32	011	0.8	3276.8	
/64	100	1.6	6553.6	
/128	101	3.2	13107.2	
/256	11x	6.4	26214.4	

Note: <sup>(1)</sup> Guaranteed by design, not tested in production.

**Table 4-35 WWDG Counting Maximum and Minimum Reset Time (APB1 PCLK1 = 27MHz)**

Prescaler	WWDG_CFG.TIMERB [2:0]	Min <sup>(1)</sup> WWDG_CFG.W[13:0] = 0x3F	Max <sup>(1)</sup> WWDG_CFG.W[13:0] = 0x3FFF	Unit
/1	00	0.152	9.71	ms
/2	01	0.303	19.42	
/3	10	0.607	38.84	
/4	11	1.214	77.67	

<sup>(1)</sup> Guaranteed by design, not tested in production.

### 4.3.15 I<sup>2</sup>C Interface Characteristics

Unless otherwise specified, the parameters listed in **Table 4-36** were measured using ambient temperature,  $f_{PCLK1}$  frequency, and  $V_{DD}$  supply voltage in accordance with **Table 4-4**.

The I<sup>2</sup>C interface of the N32G435 product conforms to the standard I<sup>2</sup>C communication protocol, but has the following limitations: SDA and SCL are not "true" open leak pins, and when configured for open leak output, the PMOS tube between the pin and  $V_{DD}$  is closed, but still exists.

I<sup>2</sup>C interface features are listed in **Table 4-36**. See Section 0 for details about the features of the input/output alternate function pins (SDA and SCL).

**Table 4-36 I<sup>2</sup>C Interface Characteristics**

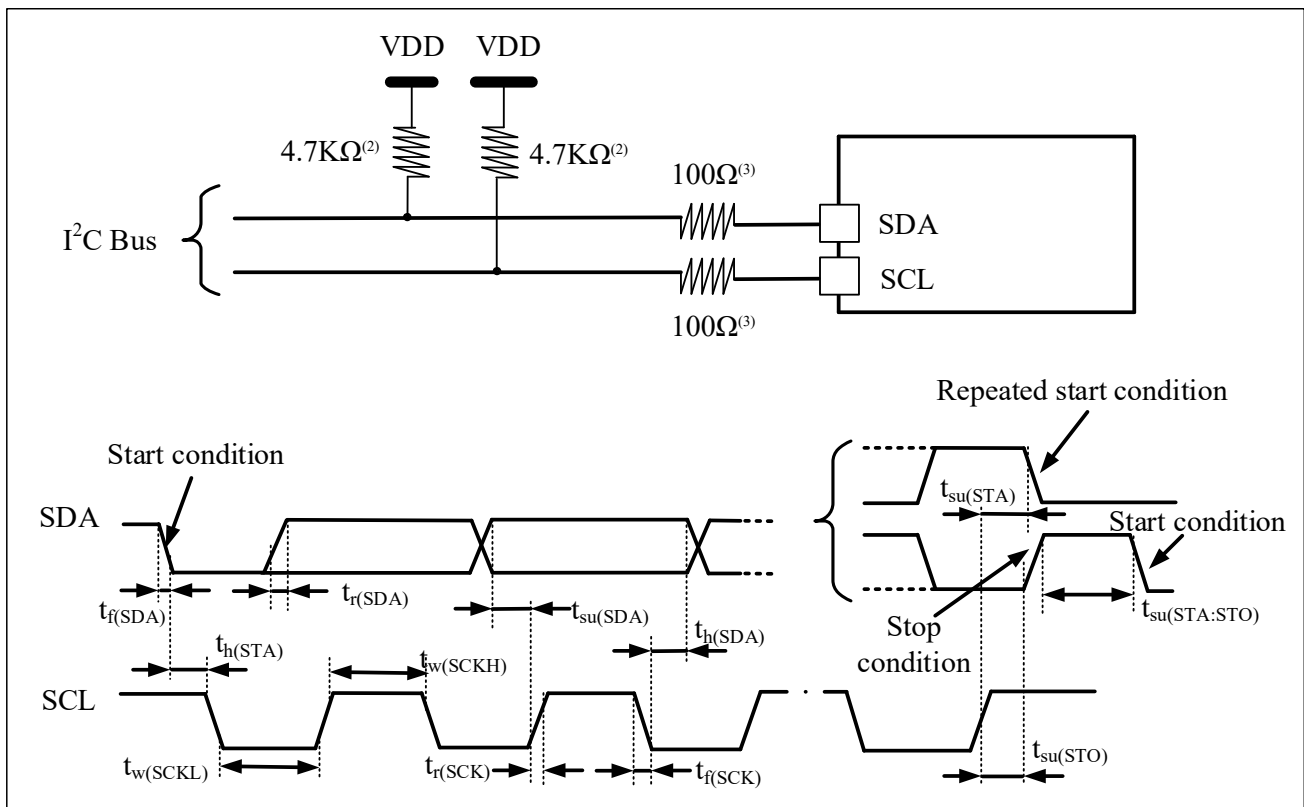
Symbol	Parameter	Standard model <sup>(1)(2)</sup>		Fast mode <sup>(1)(2)</sup>		Fast + mode <sup>(1)(2)</sup>		Unit
		Min	Max	Min	Max	Min	Max	
f <sub>SCL</sub>	I2C interface frequency	0	100	0	400	0	1000	KHz
t <sub>h(STA)</sub>	Start condition hold time	4.0	-	0.6	-	0.26	-	μs
t <sub>w(SCKL)</sub>	SCL clock low time	4.7	-	1.3	-	0.5	-	μs
t <sub>w(SCLH)</sub>	SCL clock high time	4.0	-	0.6	-	0.26	-	μs
t <sub>su(STA)</sub>	Repeat start condition setup time	4.7	-	0.6	-	0.26	-	μs
t <sub>h(SDA)</sub>	SDA data hold time	-	3.4	-	0.9	-	0.4	μs
t <sub>su(SDA)</sub>	SDA setup time	250.0	-	100	-	50	-	ns
t <sub>r(SDA)</sub> t <sub>r(SCL)</sub>	SDA and SCL rise time	-	1000	20+0.1Cb	300	-	120	ns
t <sub>f(SDA)</sub> t <sub>f(SCL)</sub>	SDA and SCL fall time	-	300	20+0.1Cb	300	-	120	ns
t <sub>su(STO)</sub>	Stop condition setup time	4.0	-	0.6	-	0.26	-	μs
t <sub>w(STO:STA)</sub>	Time from stop condition to start condition (bus idle)	4.7	-	1.3	-	0.5	-	μs
Cb	Capacitive load per bus	-	400	-	400	-	100	pf
t <sub>v(SDA)</sub>	Data validity time	-	3.45	-	0.9	-	0.45	μs
t <sub>v(ACK)</sub>	Response time	-	3.45	-	0.9	-	0.45	μs

Notes:

<sup>(1)</sup> Guaranteed by design, not tested in production.

<sup>(2)</sup> To achieve the maximum frequency of standard mode I2C, f<sub>PCLK1</sub> must be greater than 2MHz. To achieve the maximum frequency of fast mode I2C, f<sub>PCLK1</sub> must be greater than 4MHz.

**Figure 4-11 I<sup>2</sup>C Bus AC Waveform and Measuring Circuit<sup>(1)</sup>**



Notes:

(1) The measuring point is set at the CMOS level:  $0.3V_{DD}$  and  $0.7V_{DD}$ .

(2) The pull-up resistance depends on the I2C interface speed.

(3) The resistance value depends on the actual electrical characteristics. The signal line can be directly connected without serial resistance.

### 4.3.16 SPI/I<sup>2</sup>S Interface Characteristics

Unless otherwise specified, the SPI parameters listed in **Table 4-37** and the I<sup>2</sup>S parameters listed in **Table 4-38** are measured using ambient temperature,  $f_{PCLKx}$  frequency, and  $V_{DD}$  supply voltage in accordance with **Table 4-4**.

See section 0 for details on the characteristics of the I/O multiplexed pins (NSS, SCLK, MOSI, MISO for SPI, WS, CLK, SD for I<sup>2</sup>S).

**Table 4-37 SPI Characteristics** <sup>(1)</sup>

Symbol	Parameter	Condition		Min	Max	Unit
$f_{SCLK}$ $1/t_c(SCLK)$	SPI clock frequency	Master mode		-	27	MHz
		Slave mode		-	27	
$t_{r(SCLK)}$ $t_{f(SCLK)}$	SPI clock rise and fall time	Load capacitance: C = 30pF		-	8	ns
DuCy(SCK)	SPI from the input clock duty cycle	SPI from the pattern		45	55	%
$t_{su(NSS)}^{(1)}$	NSS setup time	Slave mode		$4t_{PCLK}$	-	ns
$t_{h(NSS)}^{(1)}$	NSS hold time	Slave mode		$2t_{PCLK}$	-	ns
$t_{w(SCLKH)}^{(1)}$ $t_{w(SCLKL)}^{(1)}$	SCLK high and low time	Master mode		$t_{PCLK}$	$t_{PCLK} + 2$	ns
$t_{su(MI)}^{(1)}$	Data entry setup time	Master mode	SPI1	6.2	-	ns
			SPI2	5	-	
$t_{su(SI)}^{(1)}$		Slave mode	SPI1	6.3	-	
			SPI2	3	-	
$t_{h(MI)}^{(1)}$	Data entry hold time	Master mode		5	-	ns
$t_{h(SI)}^{(1)}$		Slave mode		5.2	-	
$t_{a(SO)}^{(1)(2)}$	Data output access time	Slave mode, $f_{PCLK} = 20\text{MHz}$		0	$3t_{PCLK}$	ns
$t_{dis(SO)}^{(1)(3)}$	Disable time of data output	Slave mode		2	10	ns
$t_{v(SO)}^{(1)}$	Valid time of data output	Slave mode (after enable edge)	SPI1	-	20	ns
			SPI2	-	17	
$t_{v(MO)}^{(1)}$		Master mode (after enabling edge)	SPI1	-	5	
			SPI2	-	4	
$t_{h(SO)}^{(1)}$	Data output hold time	Slave mode (after enable edge)		6.2	-	ns
$t_{h(MO)}^{(1)}$		Master mode (after enabling edge)		- 1	-	

Notes:

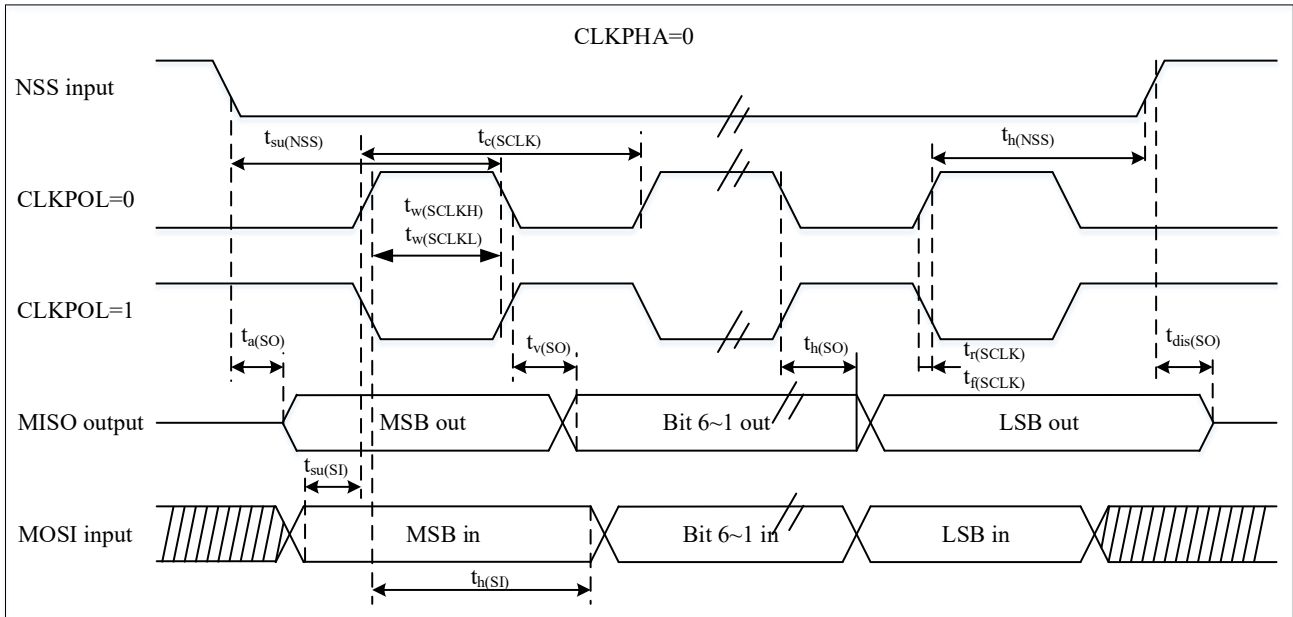
(1) Guaranteed by design, not tested in production.

(2) The minimum value represents the minimum time to drive the output, and the maximum value represents the maximum time to get the data correctly.

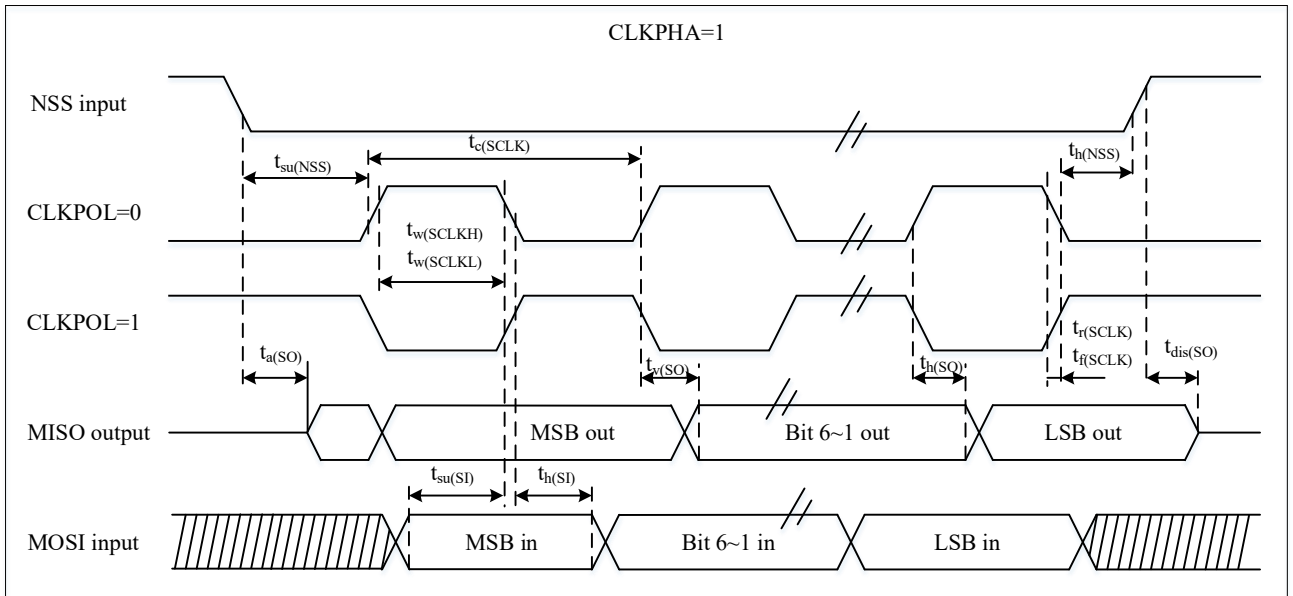
(3) The minimum value represents the minimum time for turning off the output and the maximum value represents the maximum time for placing the data line in a high resistance state.



**Figure 4-12 SPI Timing Diagram-Slave Mode and CPHA=0**

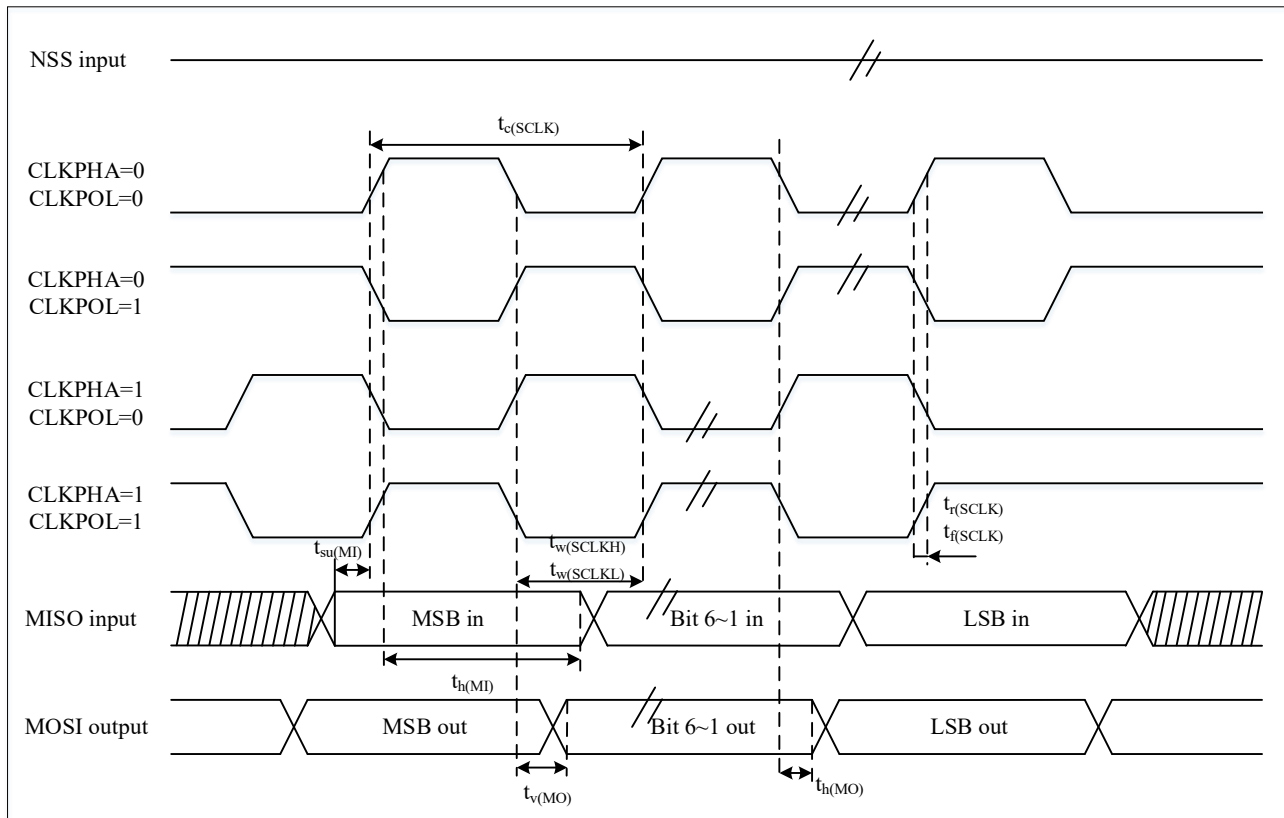


**Figure 4-13 SPI Timing Diagram-Slave Mode and CPHA=1<sup>(1)</sup>**



Note: <sup>(1)</sup> The measuring point is set at the CMOS level:  $0.3V_{DD}$  and  $0.7V_{DD}$ .

Figure 4-14 SPI Timing Diagram-Master Mode <sup>(1)</sup>



Note: <sup>(1)</sup> The measuring point is set at the CMOS level: 0.3V and 0.7V<sub>DD</sub>.

Table 4-38 I<sup>2</sup>S Characteristics <sup>(1)</sup>

Symbol	Parameter	Condition	Min	Max	Unit	
DuCy(SCK)	I <sup>2</sup> S clock duty cycle	I2S Slave mode	30	70	%	
$f_{CLK}$ $1/t_{c(CLK)}$	I <sup>2</sup> S clock frequency	Master mode (32 bit)	-	64*F <sub>S</sub> <sup>(3)</sup>	MHz	
		Slave mode (32 bit)	-	64*F <sub>S</sub> <sup>(3)</sup>		
$t_{r(CLK)}$	I <sup>2</sup> S clock rise and fall time	Load capacitance: CL = 50pF	-	8	ns	
$t_{v(WS)}^{(1)}$	WS valid time	Master mode	I2S1: 5.3 I2S2: 5	-		
$t_{h(WS)}^{(1)}$	WS hold time	Master mode	0	-		
$t_{su(WS)}^{(1)}$	WS setup time	Slave mode	I2S1: 5.5 I2S2: 5	-		
$t_{h(WS)}^{(1)}$	WS hold time	Slave mode	I2S1: 7 I2S2: 3.6	-		
$t_{w(CLKH)}^{(1)}$	CLK high and low times	Master mode, $f_{CLK} = 16\text{MHz}$ , audio 48kHz	312.5	-		
$t_{w(CLKL)}^{(1)}$			345	-		
$t_{su(SD\_MR)}^{(1)}$	Data entry setup time	The main receiver	I2S1: 6.5 I2S2: 5	-		
$t_{su(SD\_SR)}^{(1)}$			Slave mode	I2S1: 2.5 I2S2: 2.5		-
$t_{h(SD\_MR)}^{(1)(2)}$		Data entry hold time		Master receiver		I2S1: 4.4

Symbol	Parameter	Condition	Min	Max	Unit
$t_{h(SD\_SR)}^{(1)(2)}$			I2S2	5.2	-
		Slave mode	I2S1	4.5	-
			I2S2	5.2	-
$t_{v(SD\_ST)}^{(1)(2)}$	Valid time of data output	Slave transmitter (after the enabled edge)	I2S1	-	22
			I2S2	-	22
$t_{h(SD\_ST)}^{(1)}$	Data output hold time	Slave generator (after enable edge)	I2S1	4	-
			I2S2	4	-
$t_{v(SD\_MT)}^{(1)(2)}$	Valid time of data output	Master generator (after enabling edge)	I2S1	-	5.6
			I2S2	-	4.5
$t_{h(SD\_MT)}^{(1)}$	Data output hold time	Master generator (after enabling edge)	0.5	-	

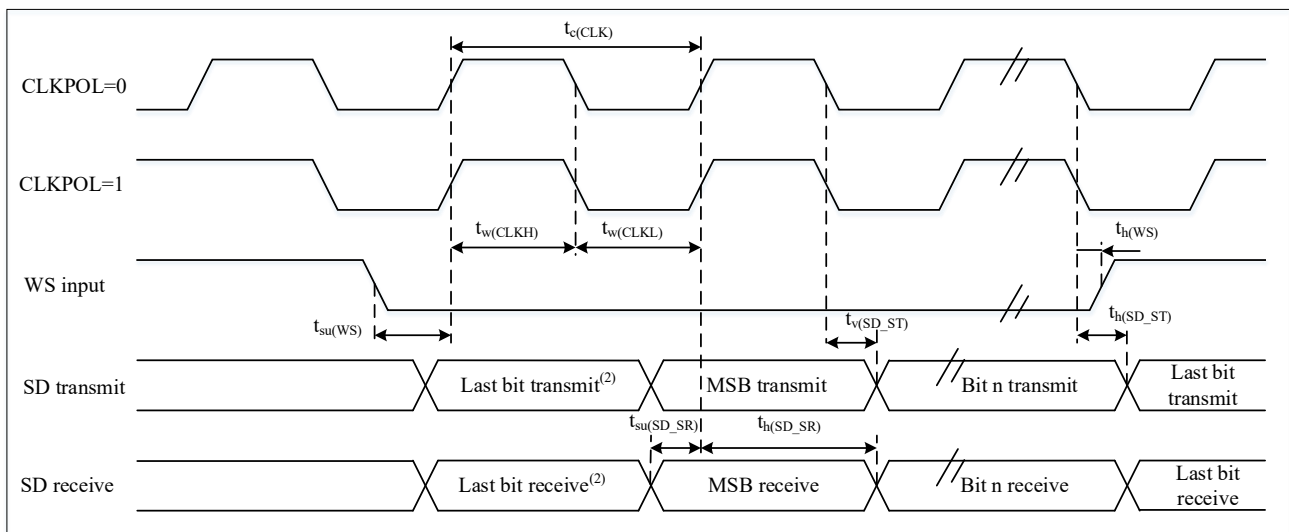
Notes:

<sup>(1)</sup> Guaranteed by design, not tested in production.

<sup>(2)</sup> Depends on  $f_{PCLK}$ . For example, if  $f_{PCLK}=16\text{MHz}$ , then  $T_{PCLK}=1/f_{PCLK}=125\text{ns}$ .

<sup>(3)</sup> Audio signal sampling frequency.

**Figure 4-15 I<sup>2</sup>S Slave Mode Timing Diagram (Philips Protocol) <sup>(1)</sup>**

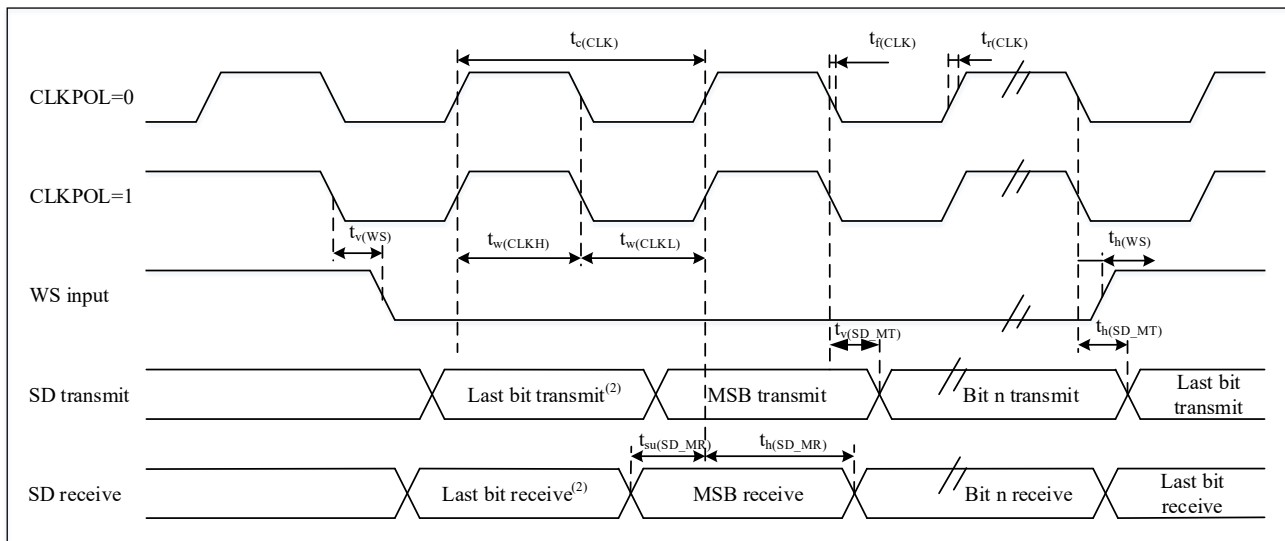


Notes:

<sup>(1)</sup> The measuring point is set at the CMOS level:  $0.3V_{DD}$  and  $0.7V_{DD}$ .

<sup>(2)</sup> Send/receive of the last byte. There is no least significant send/receive before the first byte.

Figure 4-16 I<sup>2</sup>S Master Mode Timing Diagram (Philips Protocol) <sup>(1)</sup>



Notes:

<sup>(1)</sup> The measuring point is set at the CMOS level:  $0.3V_{DD}$  and  $0.7V_{DD}$ .

<sup>(2)</sup> Send/receive of the last byte. There is no least significant send/receive before the first byte.

### 4.3.17 USB Characteristics

USB (full speed) interface is certified by the USB-IF.

Table 4-39 USB Startup Time

Symbol	Parameter	Max	Unit
$t_{\text{STARTUP}}^{(1)}$	USB transceiver startup time	1	$\mu\text{s}$

Note: <sup>(1)</sup>Guaranteed by design, not tested in production.

Table 4-40 USB DC Characteristics

Symbol	Parameter	Condition	Min <sup>(1)</sup>	Max <sup>(1)</sup>	Unit
Input level					
$V_{DD}$	USB operating voltage <sup>(2)</sup>		3.0 <sup>(3)</sup>	3.6	V
$V_{DI}^{(4)}$	Differential input sensitivity	I (USBDP and USBDM)	0.2	-	V
$V_{CM}^{(4)}$	Differential common mode range	Contains VDI ranges	0.8	2.5	
$V_{SE}^{(4)}$	Single-end receiver threshold		1.3	2.0	
Output level					
$V_{OL}$	Static output low level	1.5K $\Omega$ RL is connected to 3.6V <sup>(5)</sup>	-	0.3	V
$V_{OH}$	Static output high level	15K $\Omega$ RL is connected to $V_{SS}^{(5)}$	2.8	3.6	

Notes:

<sup>(1)</sup> All voltage measurements are based on the ground cable at the device end.

<sup>(2)</sup> USB operating voltage is 3.0~3.6V in order to be compatible with USB2.0 full speed electrical specification.

<sup>(3)</sup> The correct USB function of the N32G435 series products can be guaranteed at 2.7V, instead of dropping the electrical characteristics in the 2.7-3.0V voltage range.

<sup>(4)</sup> Based on comprehensive evaluation, not tested in production.

<sup>(5)</sup> RL is the load attached to the USB drive.

Figure 4-17 USB Timing: Definition Of Rise And Fall Time Of Data Signal

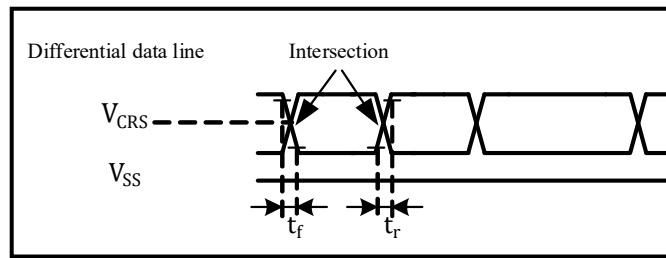


Table 4-41 Full Speed Of USB Electrical Characteristics

Symbol	Parameter	Condition	Min <sup>(1)</sup>	Max <sup>(1)</sup>	Unit
t <sub>r</sub>	Rise time <sup>(2)</sup>	C <sub>L</sub> ≤ 50pF	4	20	ns
t <sub>f</sub>	Fall time <sup>(2)</sup>	C <sub>L</sub> ≤ 50pF	4	20	ns
t <sub>rfm</sub>	Rise and fall times match	t <sub>r</sub> / t <sub>f</sub>	90	111.1	%

Notes:

<sup>(1)</sup>Guaranteed by design, not tested in production.

<sup>(2)</sup>Measured data signal from 10% to 90%.For more details, see Chapter 7 (version 2.0) of the USB specification.

### 4.3.18 Controller Area Network (CAN) Interface Characteristics

See Section 0 for details on the features of the input/output alternate function pins (CAN\_TX and CAN\_RX).

### 4.3.19 Electrical Parameters of 12-bit Analog-to-Digital Converter (ADC)

Unless otherwise specified, the parameters in **Table 4-42** are measured using ambient temperature, f<sub>HCLK</sub> frequency, and V<sub>DDA</sub> supply voltage in accordance with the conditions in **Table 4-4**.

Note: It is recommended to perform a calibration at each power-on.

Table 4-42 ADC Characteristics

Symbol	Parameter	Condition	Min	Typ	Max	Unit
V <sub>DDA</sub>	The power supply voltage	Use an external reference voltage	1.8	-	3.6	V
V <sub>REF+</sub>	Positive reference voltage	-	1.8	-	V <sub>DDA</sub>	V
f <sub>ADC</sub>	ADC clock frequency	-	-	-	72	MHz
f <sub>s</sub> <sup>(1)</sup>	Sampling rate	Resolution 12-bit	0.01	-	5.14	MHz
		Resolution 10-bit	0.012	-	6	MHz
		Resolution 8-bit	0.014	-	7.2	MHz
		Resolution 6-bit	0.0175	-	9	MHz
V <sub>AIN</sub>	Switching voltage range <sup>(2)</sup>	-	0 (V <sub>SSA</sub> or V <sub>REF-</sub> . Connect to ground)	-	V <sub>REF+</sub>	V
R <sub>ADC</sub> <sup>(1)</sup>	Sampling switch resistance	Fast channel	-	-	0.2	KΩ
R <sub>ADC</sub> <sup>(1)</sup>	Sampling switch resistance	Slow channel	-	-	0.5	KΩ
C <sub>ADC</sub> <sup>(1)</sup>	Internal sampling and holding capacitors	-	-	5	-	pF

Symbol	Parameter	Condition	Min	Typ	Max	Unit
SNDR	Singal noise distortion ration	-	-	65		dBFS
T <sub>cal</sub>	The calibration time	-	82			1/f <sub>ADC</sub>
t <sub>s</sub> <sup>(1)</sup>	Sampling time	f <sub>ADC</sub> = 72 MHz(fast channel)	0.0208		8.35	μs
		f <sub>ADC</sub> = 72 MHz(slow channel)	0.0625		8.35	
T <sub>s</sub> <sup>(1)</sup>	Sampling cycles	Fast track	1.5	-	601.5	1/f <sub>ADC</sub>
		The slow channel	4.5	-	601.5	
t <sub>STAB</sub> <sup>(1)</sup>	Power on time	-	6	10	20	μs
t <sub>CONV</sub> <sup>(1)(3)</sup>	Total conversion time (including sampling time)	-	8~614 (Sampling T <sub>s</sub> + 6.5/8.5/10.5/12.5 for successive approximation)			1/f <sub>ADC</sub>

Notes:

<sup>(1)</sup>Guaranteed by design, not tested in production.

<sup>(2)</sup>V<sub>REF+</sub> connected to V<sub>DDA</sub> internally, and V<sub>REF-</sub> connected to V<sub>SSA</sub> internally.

<sup>(3)</sup>Single conversion mode has 3 more 1/f<sub>ADC</sub> than continuous conversion mode

Formula 1: maximum R<sub>AIN</sub> formula

$$R_{AIN} < \frac{T_s}{f_{ADC} \times C_{ADC} \times \ln(2^{N+2})} - R_{ADC}$$

The above formula (Formula 1) is used to determine the maximum external impedance so that the error can be less than 1/4 LSB. Where N=12(representing 12-bit resolution).

**Table 4-43 ADC Sampling Time<sup>(1)(2)</sup>**

Input	Resolution	Rin (kΩ)	Typ of minimum sampling time (ns)	Input	Resolution	Rin (kΩ)	Typ of minimum sampling time (ns)
fast channel	12-bit	0	11	slow channel	12-bit	0	19
		0.05	12			0.05	21
		0.1	14			0.1	23
		0.2	20			0.2	30
		0.5	38			0.5	48
		1	64			1	77
		5	276			5	310
		10	543			10	607
		20	1082			20	1207
		50	2788			50	3144
fast channel	10-bit	0	10	slow channel	10-bit	0	17
		0.05	11			0.05	18
		0.1	13			0.1	20
		0.2	17			0.2	25
		0.5	32			0.5	40
		1	54			1	64
		5	229			5	257

Input	Resolution	Rin (kΩ)	Typ of minimum sampling time (ns)	Input	Resolution	Rin (kΩ)	Typ of minimum sampling time (ns)
		10	448			10	499
		20	888			20	983
		50	2223			50	2457
		100	4500			100	5001
fast channel	8-bit	0	9	slow channel	8-bit	0	14
		0.05	10			0.05	16
		0.1	11			0.1	17
		0.2	14			0.2	21
		0.5	26			0.5	33
		1	43			1	52
		5	183			5	206
		10	358			10	399
		20	707			20	783
		50	1759			50	1941
fast channel	6-bit	0	8	slow channel	6-bit	0	12
		0.05	8			0.05	13
		0.1	9			0.1	14
		0.2	12			0.2	17
		0.5	20			0.5	25
		1	33			1	40
		5	138			5	156
		10	269			10	300
		20	531			20	588
		50	1316			50	1451
		100	2627			100	2894

Notes:

<sup>(1)</sup> Guaranteed by design, not tested in production.

<sup>(2)</sup> Typical values are obtained when  $T_A=25$  and  $V_{DD}=3.3V$ .

**Table 4-44 ADC Accuracy-Limited Test Conditions <sup>(1) (2)</sup>**

Symbol	Parameter	Condition	Typ	Max <sup>(3)</sup>	Unit
ET	Comprehensive error <sup>(4)</sup>	$f_{HCLK} = 72\text{MHz}$ , $f_{ADC} = 72\text{MHz}$ , sample Rate = 1.75m SPS, $V_{DDA} = 3.3V$ , $T_A = 25^\circ\text{C}$ Measurements are made after the ADC is calibrated $V_{REF+} = V_{DDA}$	±1.3	-	LSB
EO	Offset error <sup>(5)</sup>		±1	-	
ED	Differential linear error		±0.7	-	
EL	Integral linear error		±0.8	-	

Notes:

<sup>(1)</sup>The DC accuracy of the ADC is measured after internal calibration.

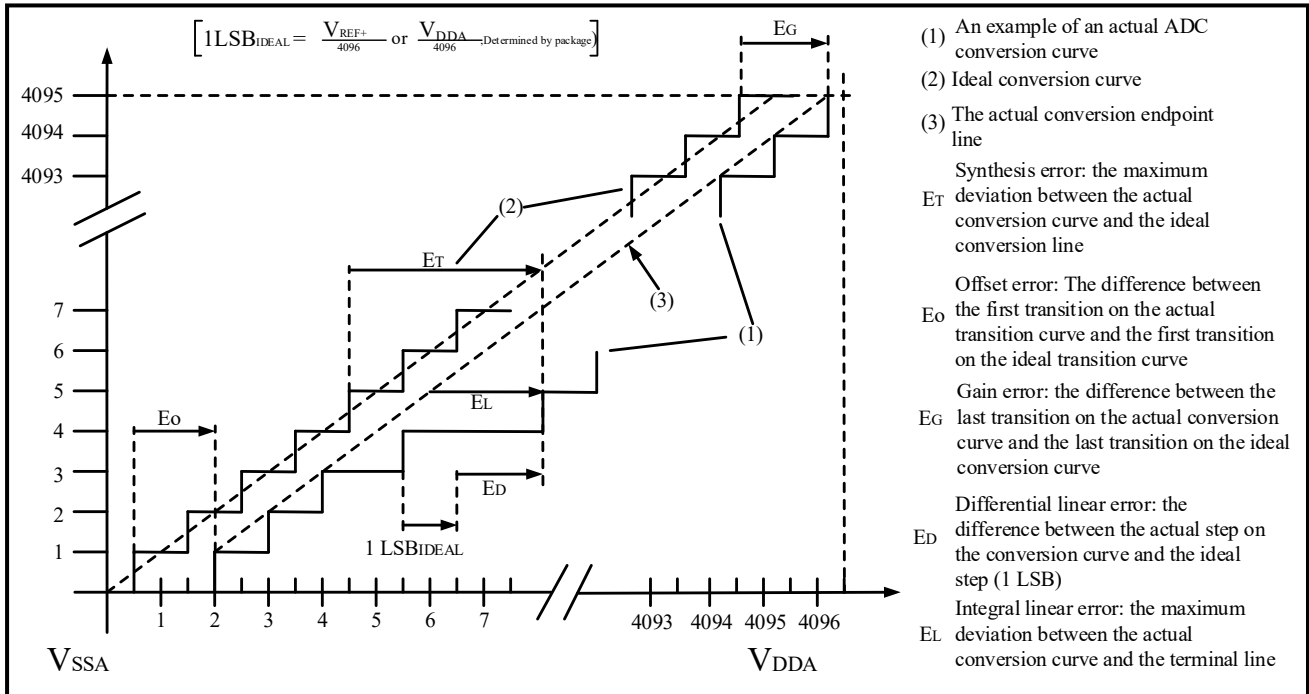
<sup>(2)</sup>ADC accuracy versus reverse injection current: It is necessary to avoid injecting reverse current on any standard analog input pin, as this can significantly reduce the accuracy of the conversion being performed on the other analog input pin. It is recommended to add a Schottky diode (between pin and ground) to standard analog pins that may generate reverse injection current.

<sup>(3)</sup>The forward injection current does not affect the ADC accuracy as long as it is within the range of  $I_{INJ(PIN)}$  and  $\Sigma I_{INJ(PIN)}$  given in **Table 4-2**

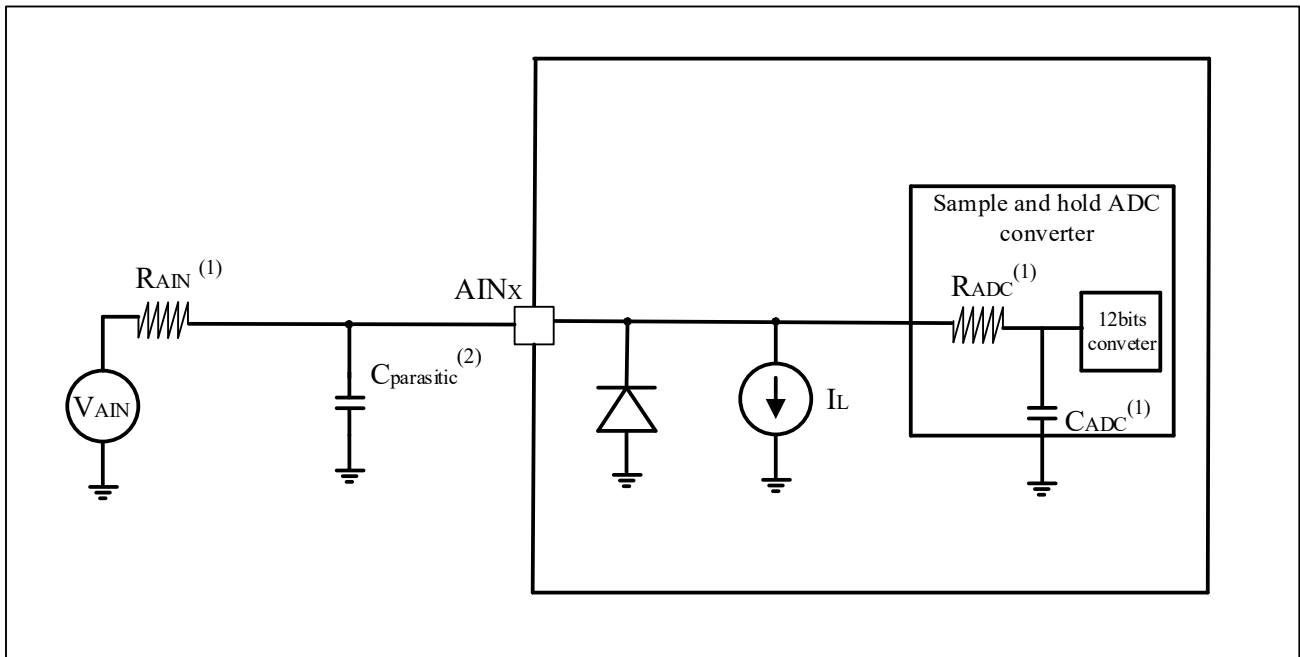
<sup>(4)</sup> Based on comprehensive evaluation, not tested in production.

<sup>(5)</sup> Guaranteed by design, not tested in production.

**Figure 4-18 ADC Precision Characteristics**



**Figure 4-19 Typical Connection Diagram Using ADC**



Notes:

<sup>(1)</sup>For values of  $R_{AIN}$ ,  $R_{ADC}$ , and  $C_{ADC}$ , see **Table 4-42**.

<sup>(2)</sup> $C_{parasitic}$  indicates parasitic capacitance on PCB (related to welding and PCB layout quality) and pads (approximately



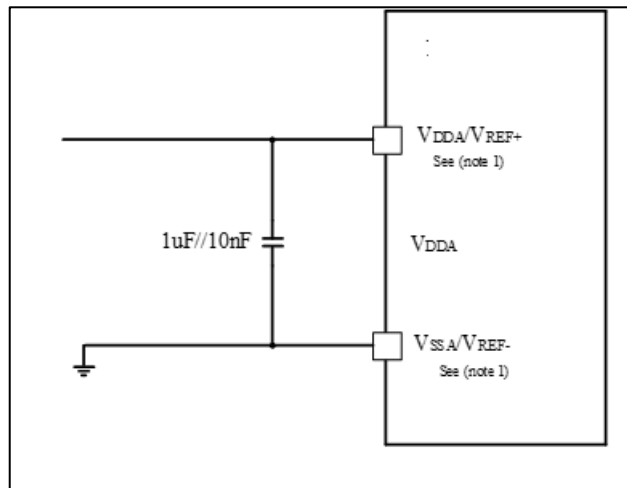
7pF). A larger  $C_{parasitic}$  value would reduce the accuracy of the conversion and the solution was to reduce  $f_{ADC}$  from medine.

**Caution: Input voltage less than -0.2V is prohibited on ADC channel**

PCB Design Suggestions

The decoupling of the power supply must be connected in accordance with **Figure 4-20**. The 10nF capacitors in the picture must be ceramic capacitors (good quality), and they should be as close as possible to the MCU chip.

**Figure 4-20 Decoupling Circuit Of Power Supply and Reference Power Supply ( $V_{REF+}$  is connected to  $V_{DDA}$ )**



Note: <sup>(1)</sup>  $V_{REF+}$  and  $V_{REF-}$  are internally connected to  $V_{DDA}$  and  $V_{SSA}$ .

**4.3.20 Internal Reference Source ( $V_{REFBUFF}$ ) Electrical Parameters**

Unless otherwise specified, the parameters in **Table 4-45** are measured using ambient temperature,  $f_{HCLK}$  frequency and  $V_{DDA}$  supply voltage in accordance with the conditions in **Table 4-4**.

**Table 4-45  $V_{REFBUFF}$  Characteristics**

Symbol	Parameter	Condition	Min	Typ	Max	Unit
$V_{DDA}$	Analog supply voltage	Normal mode	2.4	-	3.6	V
$V_{REFBUF\_OUT}$	Voltage reference output	Normal mode	-	2.048	-	V
$I_{DDA}$	$V_{REFBUF}$ consumption from $V_{DDA}$	$I_{load} = 0 \mu A$	-	600	-	$\mu A$
$t_{START}^{(1)}$	Start-up time	-	1	-	-	$\mu s$

Note: <sup>(1)</sup> Guaranteed by design, not tested in production.

**4.3.21 12-bit DAC Electrical Parameters**

Unless otherwise specified, the parameters of **Table 4-46** are measured using ambient temperature,  $f_{HCLK}$  frequency, and  $V_{DDA}$  supply voltage in accordance with the conditions of **Table 4-4**.

**Table 4-46 DAC Characteristics<sup>(1)</sup>**

Symbol	Parameter	Min	Typ	Max	Unit	Annotation
$V_{DDA}$	Analog supply voltage	2.4	-	3.6	V	
$V_{REF+}$	The reference voltage	2.4	-	3.6	V	$V_{REF+}$ must always be below $V_{DDA}$
$V_{SSA}$	Ground wire	0	-	0	V	

Symbol	Parameter	Min	Typ	Max	Unit	Annotation
R <sub>L</sub>	Load resistance when the buffer is open	5	-	-	KΩ	Minimum load resistance between DAC_OUT and V <sub>SSA</sub>
C <sub>L</sub>	The load capacitance	-	-	50	pF	The maximum capacitance on the DAC_OUT pin
I <sub>DD</sub>	DAC DC consumption in operating mode (V <sub>DDA</sub> +V <sub>REF+</sub> )	-	425	600	μA	No load. The median value is 0x800
I <sub>DDQ</sub>	DAC DC consumption in off mode (V <sub>DDA</sub> +V <sub>REF+</sub> )	-	5	350	nA	No load
DAC_OUT Min	Low DAC_OUT voltage when buffer is closed	V <sub>SS</sub> +1LSB	-	-	V	The maximum DAC output span is given. When V <sub>REF+</sub> = 3.6V corresponds to a 12-bit input value 0x0E0~0xF1C, When V <sub>REF+</sub> = 2.4V corresponds to a 12-bit input value 0x155~0xEAB.
	Low DAC_OUT voltage when buffer is open	0.2	-	-		
DAC_OUT Max	Low DAC_OUT voltage when buffer is closed	-	-	V <sub>REF+</sub> - 5LSB		
	Low DAC_OUT voltage when buffer is open	-	-	V <sub>REF+</sub> - 0.2		
DNL	Differential non linearity (Difference between two consecutive code)	-	±2	-	LSB	The DAC configuration is 12 bits
INL	Integral non linearity (difference between measured value at Code I and the value at Code i on a line drawn between Code 0 and last Code 4095)	-	±7	-	LSB	The DAC configuration is 12 bits
The offset	Offset error	-	±15	-	mV	The DAC configuration is 12 bits
	(difference between measured value at Code (0x800) and the ideal value = V <sub>REF+</sub> /2)	-	±18	-	LSB	When V <sub>REF+</sub> is 3.6V, the DAC is configured as 12 bits
Gain error	Gain error	-	±0.5	-	%	The DAC is configured as 2 bits
amplifier gain	Amplifier gain in open loop	80	85	-	dB	5KΩ load (maximum load), The median value of input is 0x800
t <sub>SETTLING</sub>	Settling time (full scale: for a 12-bit input code transition between the lowest and the highest input codes when DAC_OUT reaches final value ±1LSB)	-	5	7	μs	C <sub>LOAD</sub> ≤ 50pF R <sub>LOAD</sub> ≥ 5KΩ
Update rate	Max frequency for a correct DAC_OUT change when small variation in the input code (from code i to i+1LSB)	-	-	1	MS/s	C <sub>LOAD</sub> ≤ 50pF R <sub>LOAD</sub> ≥ 5KΩ
t <sub>WAKEUP</sub>	Wake up time from closed state (Set the CHxEN in the DAC control register)	-	6.5	10	μs	C <sub>LOAD</sub> ≤ 50pF, R <sub>LOAD</sub> ≥ 5KΩ The input code is between the minimum and maximum possible values
PSRR+	Power supply rejection ratio (to V <sub>DDA</sub> ) (static DC measurement)	-	-67	-40	dB	No R <sub>LOAD</sub> , C <sub>LOAD</sub> ≤ 50pF

Note: <sup>(1)</sup> Guaranteed by design, not tested in production.

### 4.3.22 Operational Amplifier (OPAMP) Electrical Parameters

Unless otherwise specified, the parameters in Table 4-47 are measured using ambient temperature, f<sub>HCLK</sub> frequency, and V<sub>DDA</sub> supply voltage in accordance with the conditions in Table 4-4.

Table 4-47 OPAMP Characteristics<sup>(1)</sup>

Symbol	Parameter	Condition	Min	Typ	Max	Unit
V <sub>DDA</sub>	Analog supply voltage	-	1.8	-	3.6	V
CMIR	Common mode voltage input range	-	0	-	V <sub>DDA</sub>	V

Symbol	Parameter	Condition	Min	Typ	Max	Unit
V <sub>OFFSET</sub>	Input offset voltage (after calibration)	-	-	±1	±3.5	mV
Δ V <sub>OFFSET</sub>	Input offset voltage temperature drift	-	-	10	-	UV / °C
I <sub>LOAD</sub>	Drive current	-	-	-	0.5	mA
I <sub>DDA</sub>	Operational amplifier current consumption	No load, quiescent mode	-	-	1.5	mA
TS_OPAMP_VOUT	ADC sampling time as opamp output	-	400	-	-	ns
CMMR	Common mode rejection ratio	-	-	84	-	dB
PSRR	Power rejection ratio	-	-	100	-	dB
GBW	Gain bandwidth	-	-	4	-	MHz
SR	Slew rate	-	-	2.5	-	V/μs
RLOAD	Minimum impedance load	-	4	-	-	KΩ
CLOAD	Maximum capacitive load	-	-	-	50	pF
t <sub>STARTUP</sub>	Start-up setup time	C <sub>LOAD</sub> ≤ 50 pF, R <sub>LOAD</sub> ≥ 4 kΩ, Follower configuration	-	3	-	μs
PGA Gain error	Programmable gain error	Input signal amplitude > 100mV	-	±2.5	-	%
PGA BW	PGA bandwidth for different noninverting gain	PGA Gain = 2, Cload = 50pF, Rload = 4 KΩ	-	2	-	MHz
		PGA Gain = 4, Cload = 50pF, Rload = 4 KΩ	-	1	-	
		PGA Gain = 8, Cload = 50pF, Rload = 4 KΩ	-	0.5	-	
		PGA Gain = 16, Cload = 50pF, Rload = 4 KΩ	-	0.25	-	
		PGA Gain = 32, Cload = 50pF, Rload = 4KΩ	-	0.125	-	
en	Voltage noise density	@ 1KHz, Output loaded with 4 KΩ	-	111	-	nV/√Hz
		@ 10KHz, Output loaded with 4 KΩ	-	44	-	

Note: <sup>(1)</sup> Guaranteed by design, not tested in production.

### 4.3.23 Comparator 2(COMP2) Electrical Parameters

Unless otherwise specified, the parameters in **Table 4-48** are measured using ambient temperature, f<sub>HCLK</sub> frequency, and V<sub>DDA</sub> supply voltage in accordance with the conditions in **Table 4-4**.

**Table 4-48 COMP2 Characteristics**

Symbol	Parameter	Conditions	Min	Typ	Max	Unit
V <sub>DDA</sub>	Analog supply voltage	-	1.8	-	3.6	V
V <sub>IN</sub>	Input voltage range	-	0	-	V <sub>DDA</sub>	
t <sub>START</sub> <sup>(1)</sup>	Comparator startup setup time	-	-	10	-	μs

Symbol	Parameter	Conditions	Min	Typ	Max	Unit
$t_D$	Propagation delay for 200 mV step with 100 mV overdrive	-	-	70	-	ns
$V_{OFFSET}$	Comparator input offset error	Full common mode range	-	$\pm 10$	-	mV
$V_{hys}$	Comparator hysteresis	No hysteresis	-	0	-	mV
		Low hysteresis	-	10	-	
		Medium hysteresis	-	20	-	
		High hysteresis	-	30	-	
$I_{DDA}$	Comparator current consumption	Static	-	45	-	$\mu A$
		With 50 KHz $\pm 100$ mV Overdrive Square Signal	-	47	-	

Note: <sup>(1)</sup> Guaranteed by design, not tested in production.

#### 4.3.24 Comparator 1 (COMP1) Electrical Parameters

Unless otherwise specified, the parameters in **Table 4-49** and **Table 4-50** are measured using ambient temperature,  $f_{HCLK}$  frequency, and  $V_{DDA}$  supply voltage in accordance with the conditions in **Table 4-4**.

**Table 4-49 COMP1 Normal Mode Characteristics**

Symbol	Parameter	Conditions	Min	Typ	Max	Unit
$V_{DDA}$	Analog supply voltage	-	1.8	-	3.6	V
$V_{IN}$	Input voltage range	-	0	-	$V_{DDA}$	
$t_{START}^{(1)}$	Comparator startup setup time	-	-	10	-	$\mu s$
$t_D$	Propagation delay for 200 mV step with 100 mV overdrive	-	-	70	-	ns
$V_{OFFSET}$	Comparator input offset error	Full common mode range	-	$\pm 5$	$\pm 20$	mV
$V_{hys}$	Comparison hysteresis	No hysteresis	-	0	-	mV
		Low hysteresis	-	10	-	
		Medium hysteresis	-	20	-	
		High hysteresis	-	30	-	
$I_{DDA}$	Comparator current consumption	Static	-	45	-	$\mu A$
		With 50 kHz $\pm 100$ mV overdrive square signal	-	47	-	

Note: <sup>(1)</sup> Guaranteed by design, not tested in production.

**Table 4-50 COMP1 Low Power Mode Characteristics**

Symbol	Parameter	Condition	Min	Typ	Max	Unit
$V_{DDA}$	Analog supply voltage	-	1.8	-	3.6	V
$V_{IN}$	Input voltage range	-	0	-	$V_{DDA}$	
$t_{START}^{(1)}$	Comparator startup setup time	-	-	15	-	$\mu s$
$t_D$	Propagation delay for 200 mV step with 100 mV overdrive	$V_{DDA} \geq 2.7V$	-	300	-	ns
$V_{OFFSET}$	Comparator input offset error	$V_{DDA} = 3V, 25^\circ C$	-	$\pm 10$	-	mV
$V_{hys}$	Comparison hysteresis	No hysteresis	-	0	-	mV
		Low hysteresis	-	10	-	
		Medium hysteresis	-	20	-	
		High hysteresis	-	30	-	

Symbol	Parameter	Condition	Min	Typ	Max	Unit
I <sub>DDA</sub>	Comparator current consumption	Static	-	10	-	μA
		With 50 kHz ±100 mV overdrive square signal	-	11.5	-	

Note: <sup>(1)</sup> Guaranteed by design, not tested in production.

### 4.3.25 Temperature Sensor (TS) Characteristics

Unless otherwise specified, the parameters in **Table 4-51** are measured using ambient temperature, f<sub>HCLK</sub> frequency, and V<sub>DDA</sub> supply voltage in accordance with the conditions in **Table 4-4**.

**Table 4-51 Temperature Sensor Characteristics**

Symbol	Parameter	Min	Typ	Max	Unit
T <sub>L</sub> <sup>(1)</sup>	V <sub>SENSE</sub> linearity with temperature	-	±1	±4	°C
Avg Slope <sup>(1)</sup>	Average slope	-	-4.0	-	mV/°C
V <sub>25</sub> <sup>(1)</sup>	Voltage at 25°C	-	1.32	-	V
t <sub>START</sub> <sup>(1)</sup>	Startup time	-	10	20	μs
T <sub>S temp</sub> <sup>(2)(3)</sup>	ADC sampling time when reading the temperature	8.3	-	-	μs

Notes:

<sup>(1)</sup> Based on comprehensive evaluation, not tested in production.

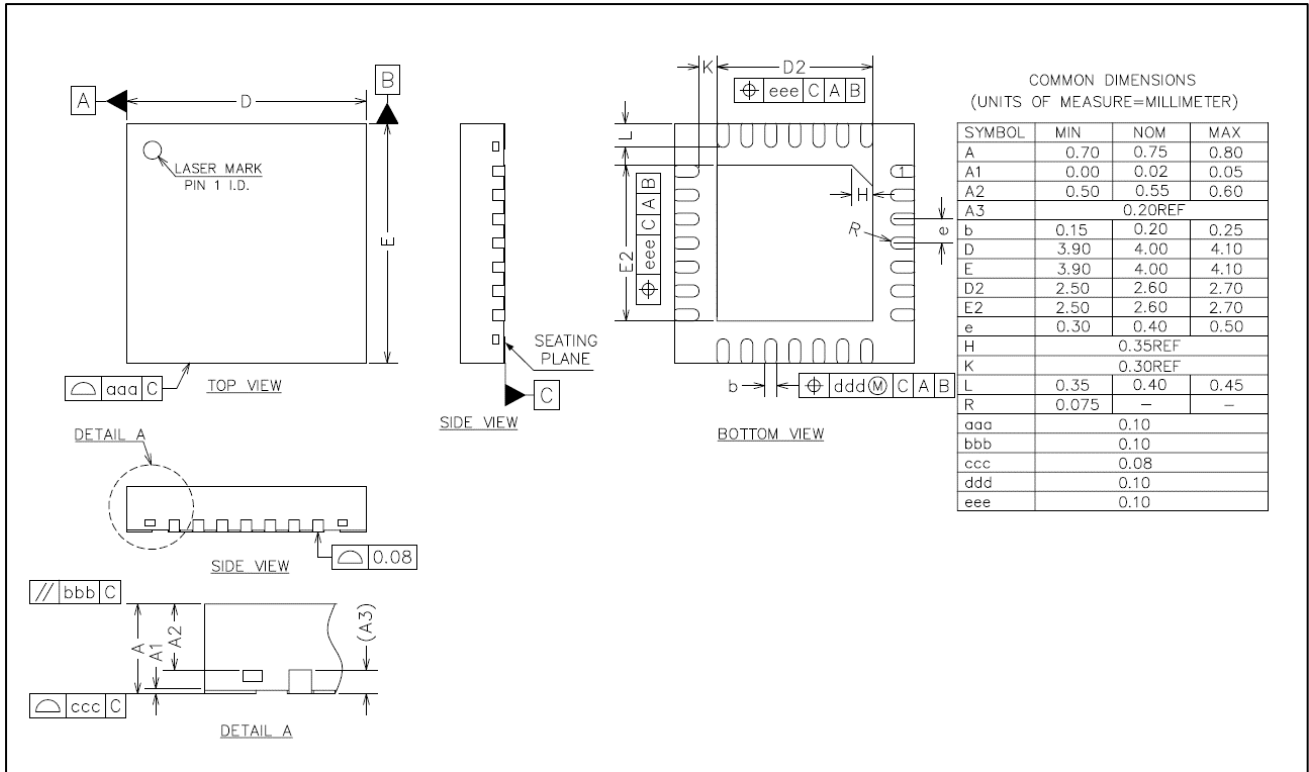
<sup>(2)</sup> Guaranteed by design, not tested in production.

<sup>(3)</sup> Shortest sampling time can be determined in the application by multiple iterations.

## 5 Packages

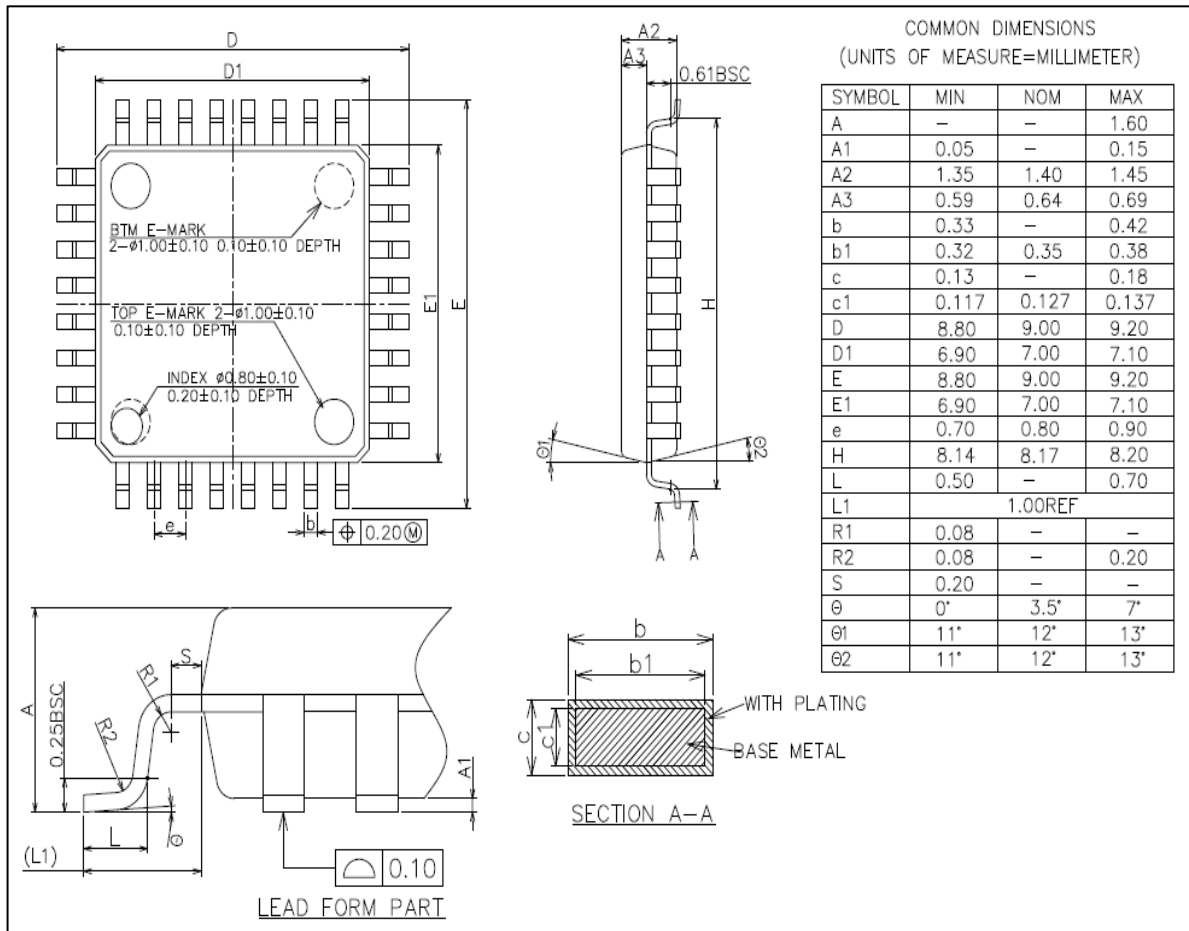
### 5.1 QFN28 (4mm×4mm)

Figure 5-1 QFN28(4mmx4mm) Package Dimensions



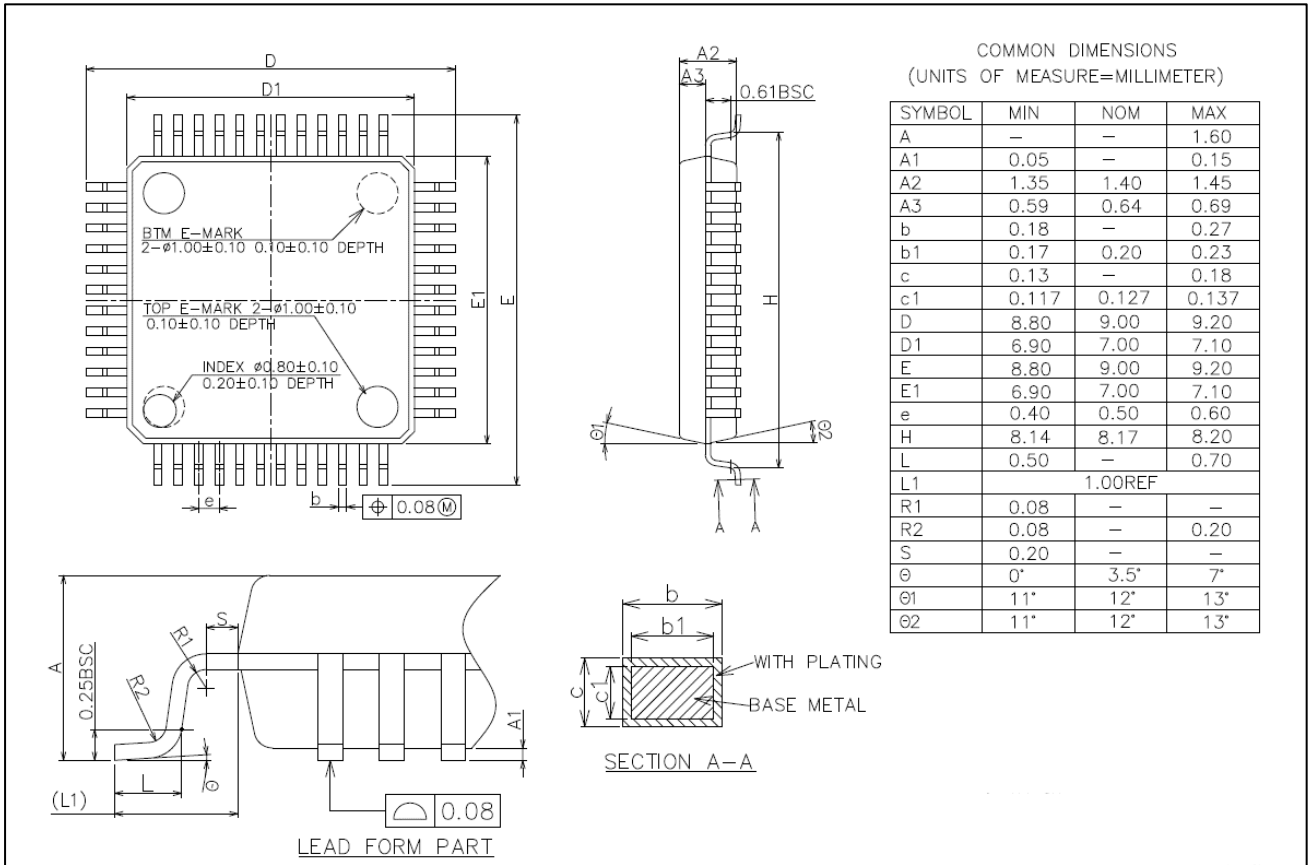
**5.2 LQFP32 (7mm×7mm)**

**Figure 5-2 LQFP32(7mmx7mm) Package Dimensions**



**5.3 LQFP48 (7mm×7mm)**

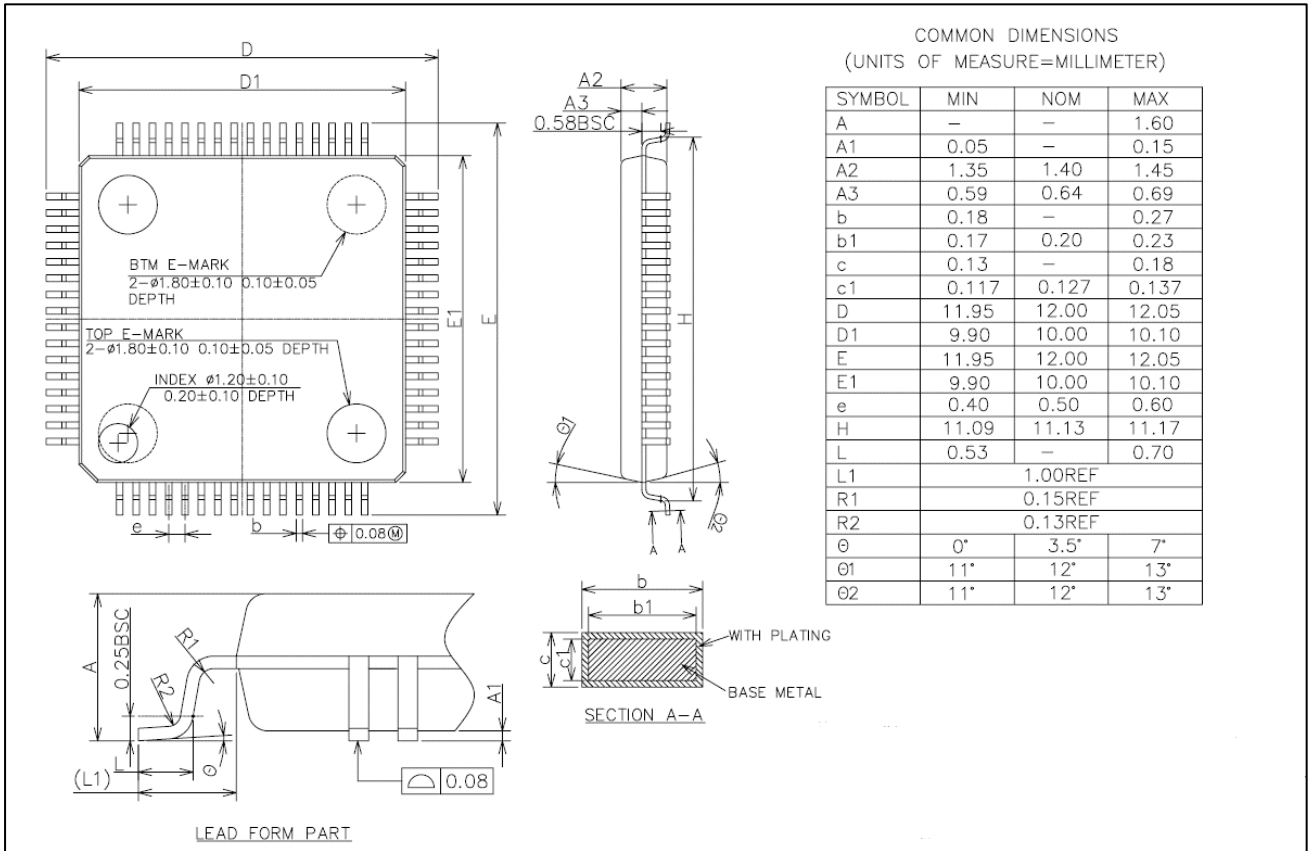
**Figure 5-3 LQFP48(7mmx7mm) Package Dimensions**





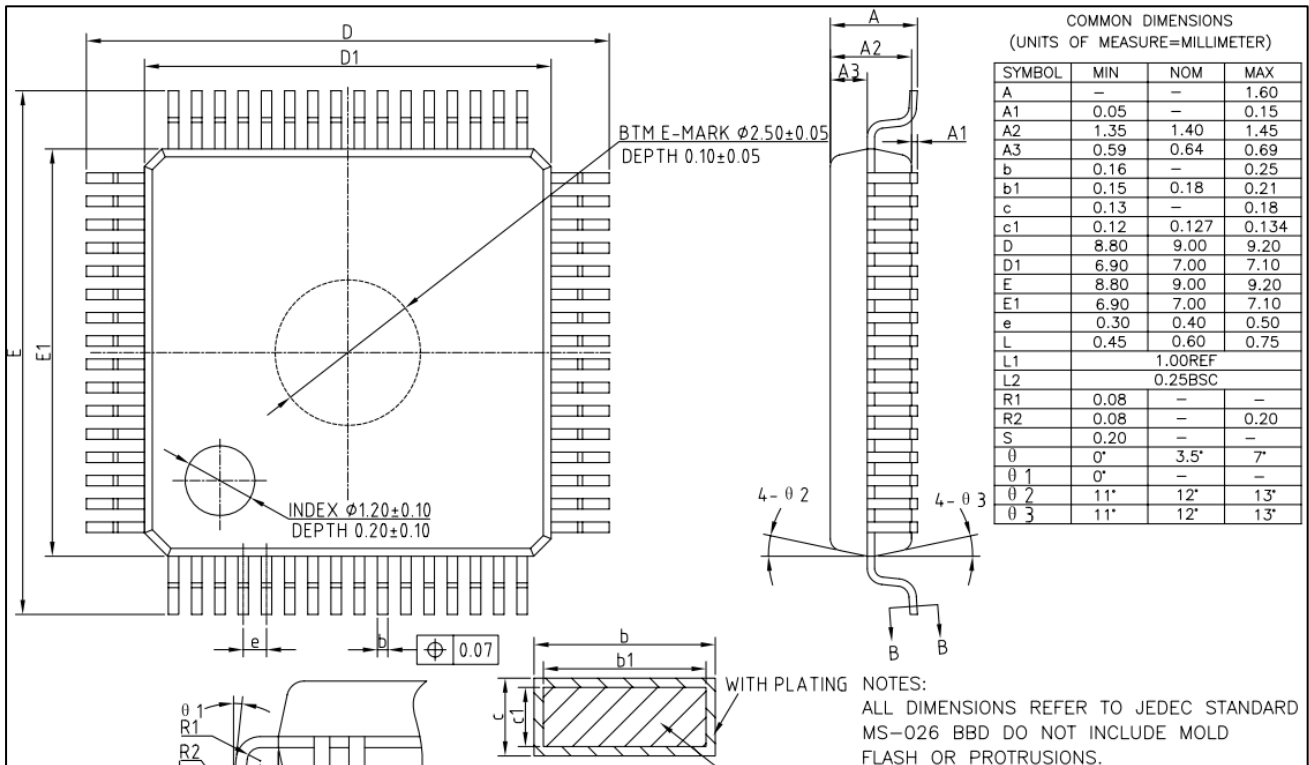
**5.4 LQFP64 (10mm×10mm)**

**Figure 5-4 LQFP64 (10mm×10mm) Package Dimensions**



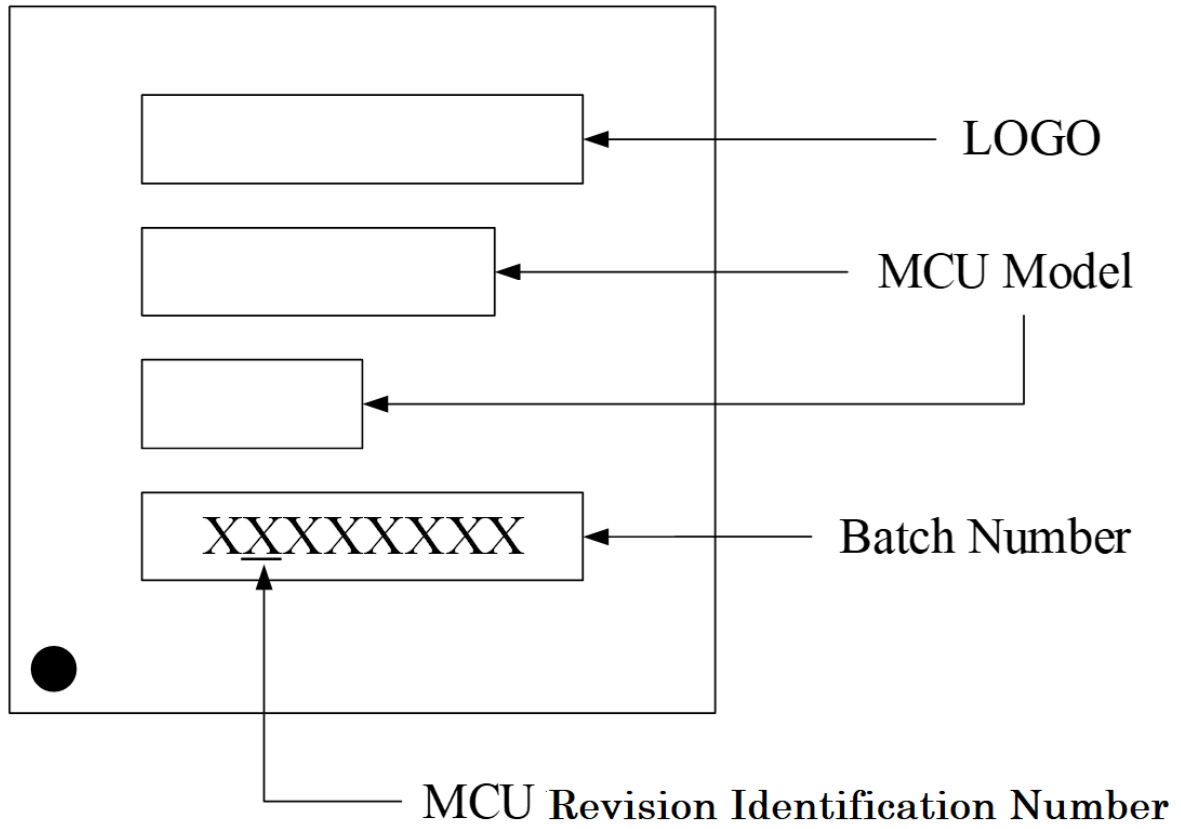
**5.5 LQFP64 (7mm×7mm)**

**Figure 5-5 LQFP64(7mm×7mm) Package Dimensions**



### 5.6 Marking Information

Figure 5-6 Marking Information



## 6 Version History

Version	Date	Changes
V0.6	2020.7.29	Initial release
V0.8	2020.11.13	<ol style="list-style-type: none"> <li>Improved electrical characteristics</li> <li>Modified the maximum speed of the SPI interface to 27Mbps.</li> <li>Unified SPI interface speed unit is Mbps.</li> </ol>
V0.9	2021.01.25	<ol style="list-style-type: none"> <li>Added N32G435G8Q7 model, pin definition, package size information</li> </ol>
V1.0	2021.04.15	<ol style="list-style-type: none"> <li>4.3 Chapter Data Check</li> </ol>
V1.1	2021.06.12	<ol style="list-style-type: none"> <li>Added model N32G435GBQ7.</li> <li>Modified the timing diagram of I2S master mode.</li> <li>Added PA2/PA3 COMP_INP version note.</li> <li>Added LQFP64 (7mmx7mm) model and package size.</li> <li>Added the introduction of LPRUN mode.</li> <li>Modified 4.3.18 Figure 4-19 Remove the upper tube of ADC pin.</li> <li>Modified 4.3.11 I/O port characteristics.</li> <li>Modified 4.3.7.1 MSI Maximum.</li> <li>Modified Figure 4-10</li> <li>Modified Table 3 1 IO/level to IO/structure</li> </ol>
V1.2	2022.07.11	<ol style="list-style-type: none"> <li>Modified Table 4-18 and Added Note 3</li> <li>Modified Table 2-1 Timer function comparison</li> <li>Added 4.3.19 ADC chapter notes</li> <li>Deleted 3.2 Pin Alternate Definition Note 4 PC13, PC14 and PC15 pins can only sink limited current (3mA)</li> <li>Modified Table 4-42 ADC characteristic <math>t_{STAB}</math> value</li> <li>Modified Table 4-16 to remove ESR CL restrictions</li> <li>Added NJTRST function</li> <li>Table 4-42 <math>t_{CONV}</math> increase Note 3</li> <li>Modified Figure 4-8 Typical application using 32.768kHz crystal</li> <li>Added Table 4-32, Table 4-33, Table 4-34, and Table 4-35</li> <li>Modified Table 4-2 NRST pin injection current</li> <li>Modified the number of shielded interrupt channels of interrupt controller</li> <li>Revise the number of edge detectors of EXTI in Section 2.3</li> <li>Revise the CPU frequency requirements for USB usage in Section 2.4</li> </ol>

	<ol style="list-style-type: none"> <li>15. Added the description of LP-sleep mode in Section 2.10</li> <li>16. Added the wake up condition of STOP2 mode in 2.10</li> <li>17. Revise PMBus compatibility in I2C main Features in 2.14</li> <li>18. Revise CRC calculation time to 1 AHB clock cycle</li> <li>19. Modified the actual frequency deviation of the HSI oscillator in Note 3 of Table 4-18</li> <li>20. Modified the conditions of the power supply current in Table 4-22: Read mode, fHCLK = 108MHz, three waiting periods</li> <li>21. Revise GPIOx_DS.DSy[1:0] of 4/8mA in Table 4-29</li> <li>22. Modified Table 4-37 SPI slave mode input clock duty cycle</li> <li>23. Modified the maximum and minimum values of V<sub>REFINT</sub> in Table 4-7 and delete the V<sub>REFBUFFER</sub></li> <li>24. Modified the minimum value of f<sub>HSE_ext</sub> in Table 4-13 and Added (Bypass mode) to the table name</li> <li>25. Modified the maximum value of V<sub>LSEL</sub> in Table 4-14 and Added (Bypass mode) to the table name</li> <li>26. Figure 4-5 and Figure 4-6 are modified</li> <li>27. Modified the description of Table 4-15 and comments</li> <li>28. Figure 4-7 Added comment 2</li> <li>29. Modified the maximum and minimum gm values in Table 4-16. Added comment 4 and comment 5</li> <li>30. Modified the maximum, typical, and minimum values in Table 4-18. Added comment 4 and comment 5</li> <li>31. Modified the typical and maximum values for t<sub>SU(LSI)</sub> and typical values for I<sub>DD(LSI)</sub> in Table 4-19</li> <li>32. Modified the conditions listed in Table 4-24</li> <li>33. Table 4-25 Added +85 °C, Added comments 1 and comment 2</li> <li>34. Modified the minimum, typical, and maximum values in Table 4-26 and Modified the comments for the table</li> <li>35. Added Table 4-27 and table comments</li> <li>36. Modified The conditions in Table 4-28, and Added comment 3</li> <li>37. Delete V<sub>CRS</sub> listed in Table 4-41</li> <li>38. Table 4-43 and Added table comments</li> <li>39. Added comment 5 in Table 4-44</li> <li>40. Figure 4-19 is modified</li> <li>41. Modified the minimum and maximum values of V<sub>REFBUF_OUT</sub> in Table 4-45</li> </ol>
--	--

		<p>42. Table 4-46 Added DAC_OUT Min and DAC_OUT Max, modified the typical values for DNL, INL, and offsets, and modified the typical values and maximum values for <math>t_{SETTLING}</math></p> <p>43. Modified the typical value and maximum value of <math>I_{LOAD}</math> and typical value of SR in Table 4-47</p> <p>44. Modified the minimum, typical, and maximum values of Avg_Slope in Table 4-51</p> <p>45. Modified the condition and minimum value of <math>t_{RET}</math> in Table 4-23</p> <p>46. Modified the Figure 4-16</p>
V1.3	2022.08.30	<p>1. Modified the description of Note 2 in Table 4-42</p> <p>2. Modified the description of the output drive current and output voltage section in chapter 4.3.12</p> <p>3. Added "-" to blank (no data) part of all tables in Section 4</p> <p>4. Modified the description of Note 3 in Table 4-18</p> <p>5. Added note 9 in chapter 3.2</p> <p>6. Added note 7 in chapter 4.3.12</p> <p>7. Delete OPAMP2_VINP function from PB0 in chapter 3.2</p> <p>8. Modified the table of Flash endurance and data retention life in chapter 4.3.10</p> <p>9. Modified Table 6-1 I2C interface characteristics</p> <p>10. Modified PC8 pin serial number in table 3-1</p>
V1.4	2023.02.10	<p>1. Note 4 is Added to describe MSI oscillator characteristics in chapter 4.3.7.1</p> <p>2. STANDBY mode wakeup delete RTC periodic wakeup in chapter 2.10</p>

## 7 Disclaimer

This document is the exclusive property of NSING TECHNOLOGIES PTE. LTD.(Hereinafter referred to as NSING).

This document, and the product of NSING described herein (Hereinafter referred to as the Product) are owned by NSING under the laws and treaties of Republic of Singapore and other applicable jurisdictions worldwide. The intellectual properties of the product belong to Nations Technologies Inc. and Nations Technologies Inc. does not grant any third party any license under its patents, copyrights, trademarks, or other intellectual property rights. Names and brands of third party may be mentioned or referred thereto (if any) for identification purposes only. NSING reserves the right to make changes, corrections, enhancements, modifications, and improvements to this document at any time without notice. Please contact NSING and obtain the latest version of this document before placing orders. Although NATIONS has attempted to provide accurate and reliable information, NATIONS assumes no responsibility for the accuracy and reliability of this document. It is the responsibility of the user of this document to properly design, program, and test the functionality and safety of any application made of this information and any resulting product. In no event shall NATIONS be liable for any direct, indirect, incidental, special, exemplary, or consequential damages arising in any way out of the use of this document or the Product.

NATIONS Products are neither intended nor warranted for usage in systems or equipment, any malfunction or failure of which may cause loss of human life, bodily injury or severe property damage. Such applications are deemed, 'Insecure Usage'. Insecure usage includes, but is not limited to: equipment for surgical implementation, atomic energy control instruments, airplane or spaceship instruments, all types of safety devices, and other applications intended to supporter sustain life. All Insecure Usage shall be made at user's risk. User shall indemnify NATIONS and hold NATIONS harmless from and against all claims, costs, damages, and other liabilities, arising from or related to any customer's Insecure Usage Any express or implied warranty with regard to this document or the Product, including, but not limited to. The warranties of merchantability, fitness for a particular purpose and non-infringement are disclaimed to the fullest extent permitted by law. Unless otherwise explicitly permitted by NATIONS, anyone may not use, duplicate, modify, transcribe or otherwise distribute this document for any purposes, in whole or in part.