

# Design Guide

---

## Hardware Design Guide

---

### Introduction

This document details the hardware design checklist for N32G45X&N32G4FR series MCUs to provide users with hardware design guidance.

## CONTENTS

<b>1. N32G45X&amp;N32G4FR Series MCU Hardware Design Checklist.....</b>	<b>3</b>
1.1 Introduction to Power Supply .....	3
1.2 VDD Power Supply Scheme.....	3
1.3 Spare Battery .....	3
1.4 External Pin Reset Circuit.....	3
1.5 External Clock Circuit .....	4
1.6 Boot Pin Connection.....	4
1.7 Independent ADC Converter .....	5
1.8 IO Pulse Processing During Power On.....	7
1.9 IO Voltage Tolerance.....	9
1.10 ESD Protection Design .....	10
1.10.1 PCB Design.....	10
1.10.2 ESD Protection Devices.....	10
1.11 Debug Interface.....	10
1.12 BOOT Serial Interface .....	11
<b>2. Overall Design Suggestions .....</b>	<b>12</b>
<b>3. Minimum System Reference Design Schematic .....</b>	<b>13</b>
3.1 LQFP100.....	13
3.2 LQFP80.....	14
3.3 LQFP64.....	14
3.4 LQFP48.....	15
3.5 LQFP32.....	16
3.6 QFN40 .....	17
3.7 QFN32 .....	18
<b>4. PCB LAYOUT Reference.....</b>	<b>20</b>
<b>5. Typical Fault Analysis.....</b>	<b>21</b>
5.1 Short Circuit Between Power Pins And Ground.....	21
5.2 GPIO Damage.....	21
5.3 ADC Sampling Inaccurate .....	21
<b>6. Version History.....</b>	<b>22</b>
<b>7. Disclaimer.....</b>	<b>23</b>

# 1. N32G45X&N32G4FR Series MCU Hardware Design Checklist

## 1.1 Introduction to Power Supply

The operating voltage (VDD) of N32G45X/N32G4FR series chips is 1.8V~3.6V. The main pins include: VDD and VDDA pins. For details, please refer to the relevant datasheet.

## 1.2 VDD Power Supply Scheme

VDD is the main power supply of the MCU, which must be powered by a stable external power source. The voltage ranges from 1.8V to 3.6V, a 0.1uF decoupling capacitor should be placed nearby all VDD pins, and one VDD pin needs to add a 4.7uF decoupling capacitors additionally. For the specific design of the decoupling capacitor, please refer to the reference design schematic diagram of the minimum system of each package in Chapter 3.

VDDA is an analog power supply, which provides power for ADC, DAC, OPAMP, COMP. It is recommended to place a 0.1uF and a 1uF capacitor nearby the VDDA input pin.

## 1.3 Spare Battery

The VBAT pin mainly supplies power to the RTC unit, so that the RTC can still operate normally when the main power supply (VDD) is turned off. If there is no external battery in the application, VBAT must be connected externally to VDD.

## 1.4 External Pin Reset Circuit

A system reset occurs when a low level (external reset) occurs on the NRST pin. The reference circuit of external NRST pin reset is as follows.

Figure 1-1 System Reset Diagram

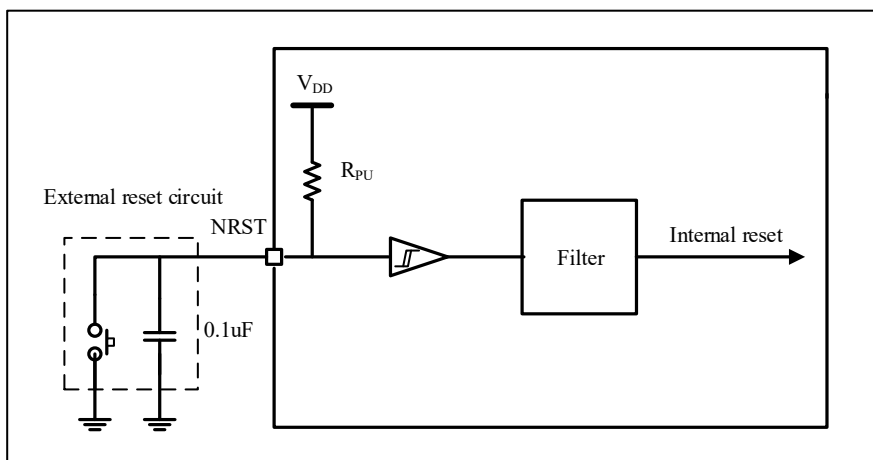

*Note: The reset pin NRST cannot be*

*left floating during design, and the external capacitor 0.1uF is given as a typical reference value. If the reset time needs to be accelerated, the NRST pin can be pulled up externally, and the typical value of the pull-up resistor is 10K. In addition, the user can decide whether to add a reset button according to the actual product*

requirements.

### 1.5 External Clock Circuit

N32G45X/N32G4FR series MCU contains 2 external clocks: external high-speed clock HSE (4MHz~32MHz) and external low-speed clock LSE (usually 32.768KHz).

Configure the corresponding load capacitors for HSE and LSE according to the characteristics of the crystal oscillator. For details, please refer to the description of the external clock characteristics in the relevant datasheet.

When using LSE, the adjacent IO pins (take LQFP64 package pins as an example: PC13 and PD0) cannot have GPIO toggle level signals. Refer to Figure 1-2 for adjacent pins. Inverted level signal will cause unstable LSE operation.

**Figure 1-2 PC13/PD14 Pins Cannot Have Flip Signals**

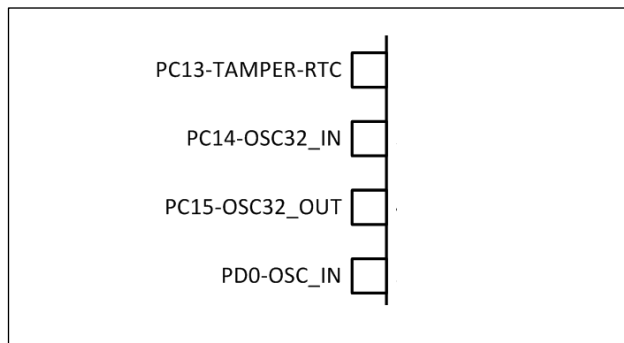

### 1.6 Boot Pin Connection

The figure below shows the external connections required for the N32G45X/N32G4FR series chip to select the boot memory. Please refer to the relevant section of the datasheet for the startup mode.

**Figure 1-3 Implementation Example Of Startup Mode**

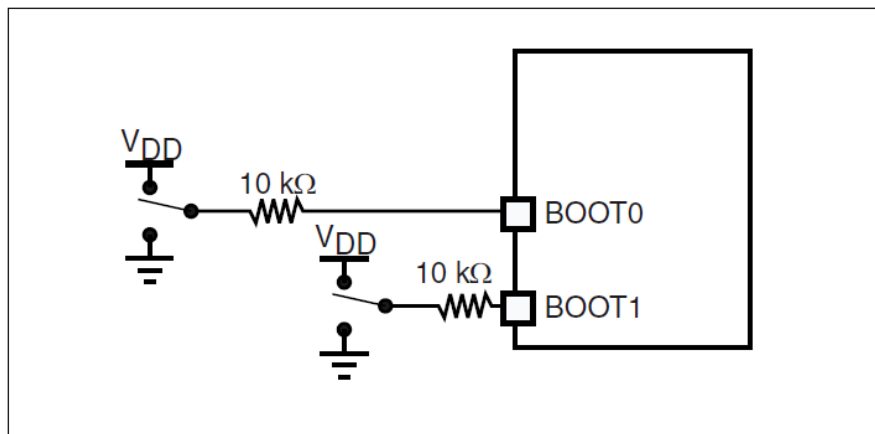

The BOOT pin is pulled high, and the chip will boot from the BOOT area after reset; the BOOT pin is pulled low, and the chip will boot from the user area after reset.

*Note: The resistance values in the figure are given as typical reference values only.*

## 1.7 Independent ADC Converter

In order to improve the conversion accuracy, the ADC has a pair of independent power supplies, an independent VDDA pin supplies power to the ADC, and the VSSA pin is used as the ground terminal of the analog power supply. It can be separately filtered and shielded from noise on the PCB to power the ADC.

Regarding the ADC circuit design, please pay attention to the following points:

- 1) When using ADC sampling, it is recommended to shorten the external wiring distance
- 2) It is recommended to keep away from some high frequency switching signals around the input signal of ADC
- 3) Note the maximum supported rates for slow and fast channels:

When the input frequency of N32G45X/N32G4FR series is 72MHZ, the sampling rate of ADC fast channel should not exceed 5Msps, and the sampling rate of ADC slow channel should not exceed 2.5Msps

- 4) During ADC conversion, the chip does not support modifying the ADC configuration. If configuration changes are needed, it is necessary to wait for the current conversion to end or disable the ADC before configuring
- 5) When a certain ADC channel is used, negative voltage (such as -0.2V) cannot be applied to other unused ADC sampling channels. If this negative voltage is applied, the voltage of the normally sampled ADC channel will be reduced, resulting in inaccurate data reading
- 6) When a certain ADC channel is used, high voltage (greater than VDD voltage) cannot be applied to other unused ADC sampling channels. If this high voltage is applied, the voltage of the normally sampled ADC channel will be pulled up, resulting in inaccurate data reading;
- 7) When using ADC, the maximum value of RAIN cannot be too large, and it needs to comply with the following formula:

$$R_{AIN} < \frac{T_s}{f_{ADC} \times C_{ADC} \times \ln(2^{N+2})} - R_{ADC}$$

**Figure 1-4 Influence of Series Resistance Of ADC Input Port**

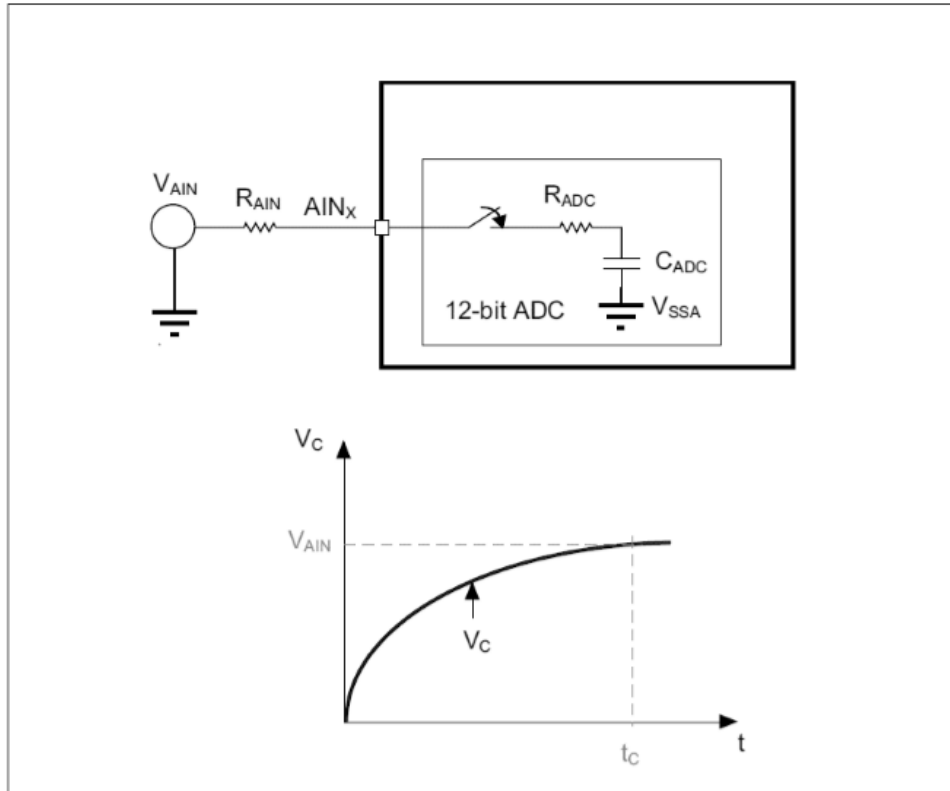

The following figure shows the ADC sampling configuration rule table under typical input impedance:

**Figure 1-5 N32G45X/N32G4FR Series ADC Sampling Configuration Rule Table**

ADC input clock frequency:72MHz				
Equivalent impedance( $\Omega$ )	Min Sampling cycle	Min Sampling Time(ns)	ADC Sampleing+ Convert Time(us)	ADC maximum sample rate (Ksps)
0	1.75	24.26	0.198	5053.8
100	2.10	29.11	0.203	4932.8
330	2.90	40.27	0.214	4675.5
470	3.39	47.06	0.221	4531.5
1000	5.24	72.78	0.246	4058.6
2200	9.43	131.00	0.305	3282.8
4700	18.17	252.31	0.426	2347.9
10000	36.68	509.46	0.683	1464.0
30000	106.55	1479.87	1.653	604.8
51000	179.91	2498.80	2.672	374.2
100000	351.09	4876.29	5.050	198.0
470000	1643.67	22828.80	23.002	43.5
1000000	3495.21	48544.56	48.718	20.5

*Note: The sampling time needs to be comprehensively configured according to the input clock and the optional sampling period of the ADC register. In principle, the ADC sampling period configuration should be greater than or equal to the minimum number of sampling periods in the table.*

## 1.8 IO Pulse Processing During Power On

During the power-on process, because of the high-impedance state of IO and the internal circuit coupling characteristics, a high-level pulse will occur on the IO at the moment of power-on (the actual high-pulse voltage value should be measured by the user). If the pulse will affect its application, it is recommended to add an appropriate capacitor (1nF~100nF) or an appropriate pull-down resistor (10K~100K) on the corresponding IO.

The following picture shows the waveform of IO (PB12) during the power-on process of the development board N32G45XVL-STB V1.1:

Figure 1-6 IO (PB12) Waveform During Power-On

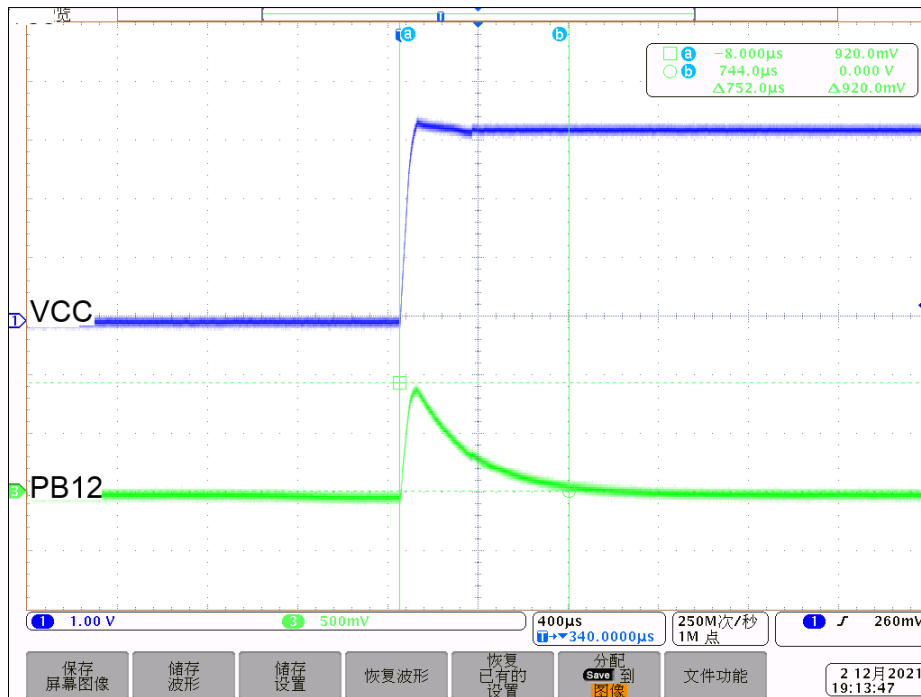

The following figure shows the waveform of the development board N32G45XVL-STB V1.1 after the IO (PB12) is added with a 10K pull-down resistor during the power-on process:



Figure 1-7 Waveform After IO (PA9) Plus Pull-Down Resistor During Power-On Process

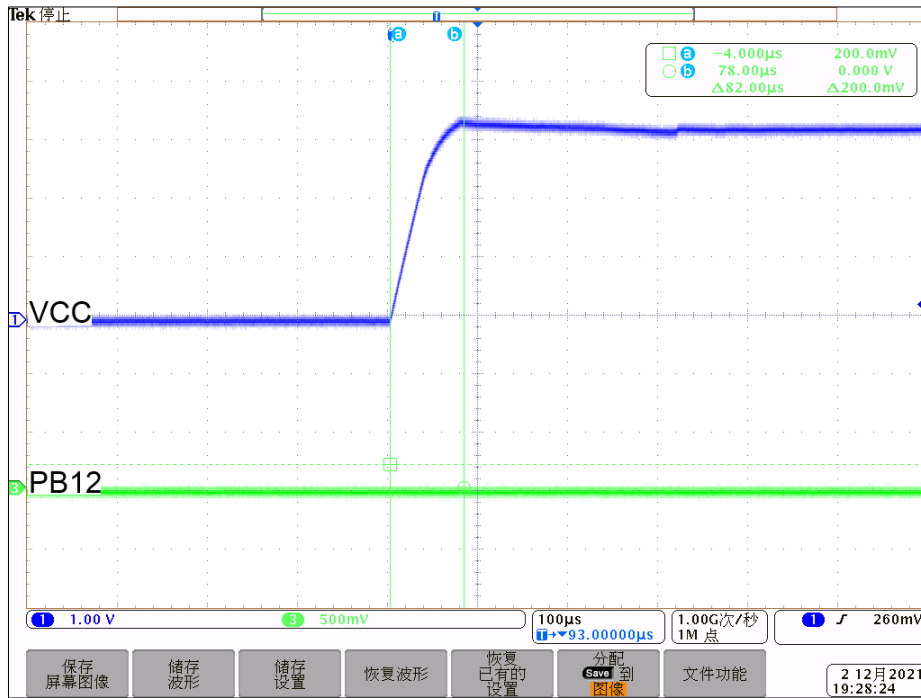

### 1.9 IO Voltage Tolerance

When using the chip, please pay attention to the voltage tolerance value of each IO. In the datasheet, the I/O structure defined by pin multiplexing indicates TC: 3.3V standard IO. This type of IO requires level conversion when communicating with external IO in different voltage domains.

Figure 1-8 I/O Structure Defined by Pin Multiplexing In The Datasheet

封装				管脚名称	类型 <sup>(1)</sup>	I/O 电平 <sup>(2)</sup>	Fail-safe <sup>(9)</sup> 支持	主功能 <sup>(3)</sup> (复位后)	可选的复用功能 <sup>(6) (8)</sup>	
QFN32	QFN40	LQFP64	LQFP80						默认	重定义
-	-	-	1	PE2	I/O	FT	Yes	PE2	TRACECK UART6_TX	DVP_HSYNC
-	-	-	2	PE3	I/O	FT	Yes	PE3	TRACED0 UART6_RX	DVP_VSYNC
-	-	1	3	VBAT	S	-	-	VBAT	-	-
-	-	2	4	PC13-TAMPER- RTC <sup>(4)</sup>	I/O	TC	Yes	PC13 <sup>(5)</sup>	TAMPER-RTC	-

Note:

TTa: 3.3V standard IO. When using the chip, pay attention to the impact of signals higher than 3.3V on IO.

## 1.10 ESD Protection Design

### 1.10.1 PCB Design

For the PCB design of ordinary two-layer boards, it is recommended to do wrapping around the signal lines, and try to cover the edges of the PCB as much as possible. If the cost allows, it can be designed with a four-layer board or a multi-layer board. In a multi-layer PCB, the ground plane acts as an important charge source, which can offset the charge on the electrostatic discharge source, which is conducive to reducing the electrostatic field band. The ground plane of the PCB can also be used as a shield for the signal line (of course, the larger the opening of the ground plane, the lower the shielding effectiveness). In addition, if a discharge occurs, since the ground plane of the PCB board is large, the charge is easily injected into the ground plane, rather than into the signal line. This will help protect the component, because the charge can be drained before causing component damage.

### 1.10.2 ESD Protection Devices

In the actual product design, the chip itself has a certain ESD protection ability. N32G45X/N32G4FR series have an MCU ESD (HBM) rating of +/-4KV. However, if there are higher ESD protection level requirement, and some pins of the chip which need direct external connection are used as the output or input port of the product, these pins are directly exposed to the outside of the product, and cannot be isolated by laying the ground or other means. Under this condition, it is generally necessary to consider an external ESD protection device. TVS diode is a typical ESD protection device. The following is an example of a typical connection method.

**Figure 1-9 TVS Connection On I/O Pins**

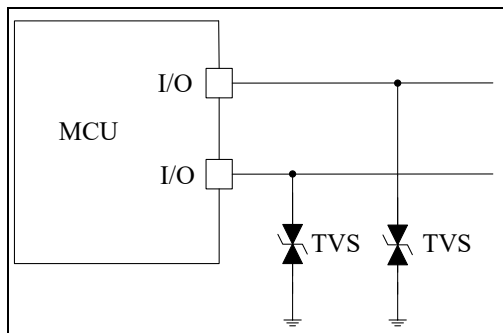

### 1.11 Debug Interface

N32G45X/N32G4FR series chips support serial interface (SWD) and JTAG debug interface, please refer to the relevant user manual for detailed application.

**Table 1-1 Debug Interface**

Debug Signal	GPIO Pins
JTMS/SWDIO	PA13
JTCK/SWCLK	PA14
JTDI	PA15
JTDO	PB3
JNTRST	PB4

## 1.12 BOOT Serial Interface

N32G45X/N32G4FR series chips support BOOT serial communication. The serial interface is as follows:

**Table 1-2 Serial Port Interface**

BOOT Serial Port	GPIO Pins
USART1_TX	PA9
USART1_RX	PA10

## 2. Overall Design Suggestions

### 1) Printed circuit board

It is recommended to use a multi-layer printed circuit board with a dedicated independent ground plane (VSS) and a dedicated independent power supply plane (VDD), which can provide good coupling performance and shielding effect. In practical applications, if a multi-layer printed circuit board cannot be used considering the economical reason, a good grounding and power supply structure must be ensured when designing the circuit.

### 2) Component layout

In PCB design, different circuits need to be laid out separately according to the different effects of each device on EMI. For example, high-current circuits, low-voltage circuits, and high-frequency devices. Thereby reducing cross-coupling on the PCB.

### 3) ground and Power (VSS, VDD)

Each module (analog circuit, digital circuit, low-sensitivity circuit) should be grounded separately, the digital ground and the analog ground should be separated, and all the grounds should be connected together at one point eventually. According to the size of the printed circuit board current, try to increase the width of the power line to reduce the loop resistance. At the same time, the direction of the power wire and the ground wire and the direction of the current should be as consistent as possible, and the power supply should be as close to the ground wire as possible to reduce the area of the loop. This helps to enhance noise immunity. The area on the PCB without devices needs to be filled with ground to provide good shielding effect.

### 4) Decoupling

All power pins need to be properly connected to power. These connections, including pads, wires, and vias, should have as low impedance as possible. The method of increasing the wiring width is usually adopted, and decoupling capacitors must be placed close to the chip for each pair of VDD and VSS pins. The figure below shows a typical layout of the power/ground pins.

Figure 2-1 Typical Layout Of VDD/VSS Pins

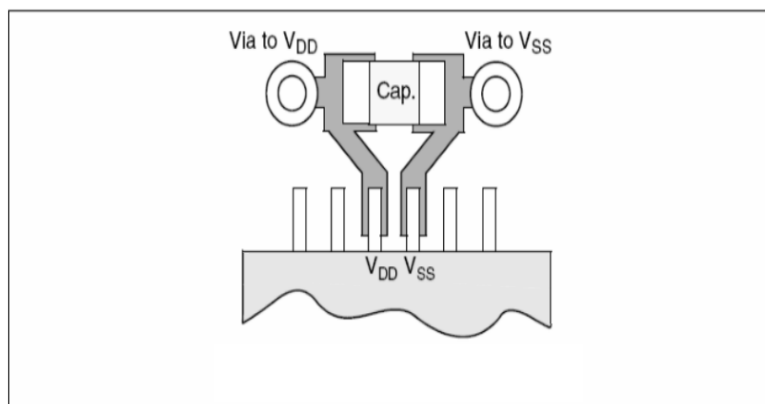

### 3. Minimum System Reference Design Schematic

#### 3.1 LQFP100

Figure 3-1 LQFP100 Package Minimum System Reference Design Schematic

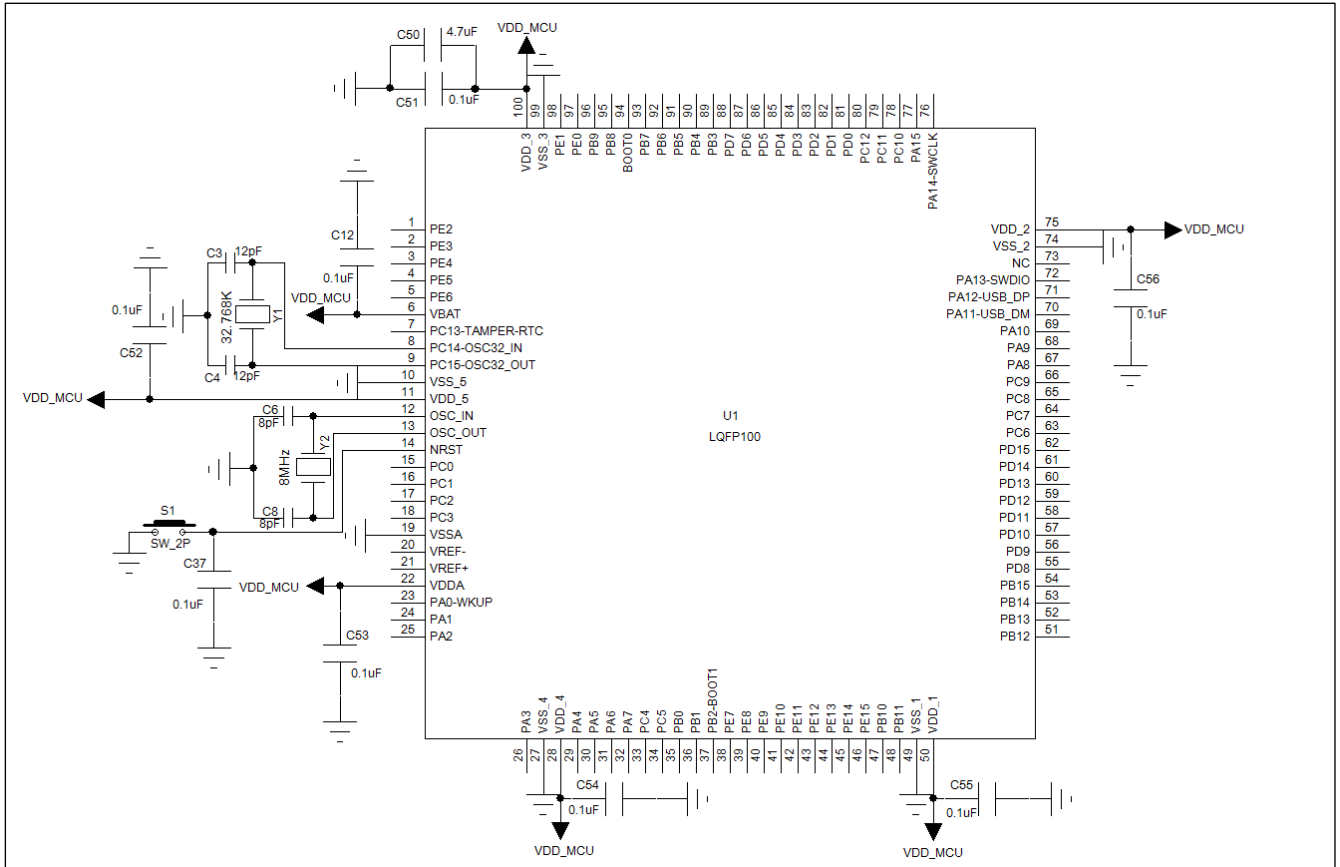

### 3.2 LQFP80

Figure 3-2 LQFP80 Package Minimum System Reference Design Schematic

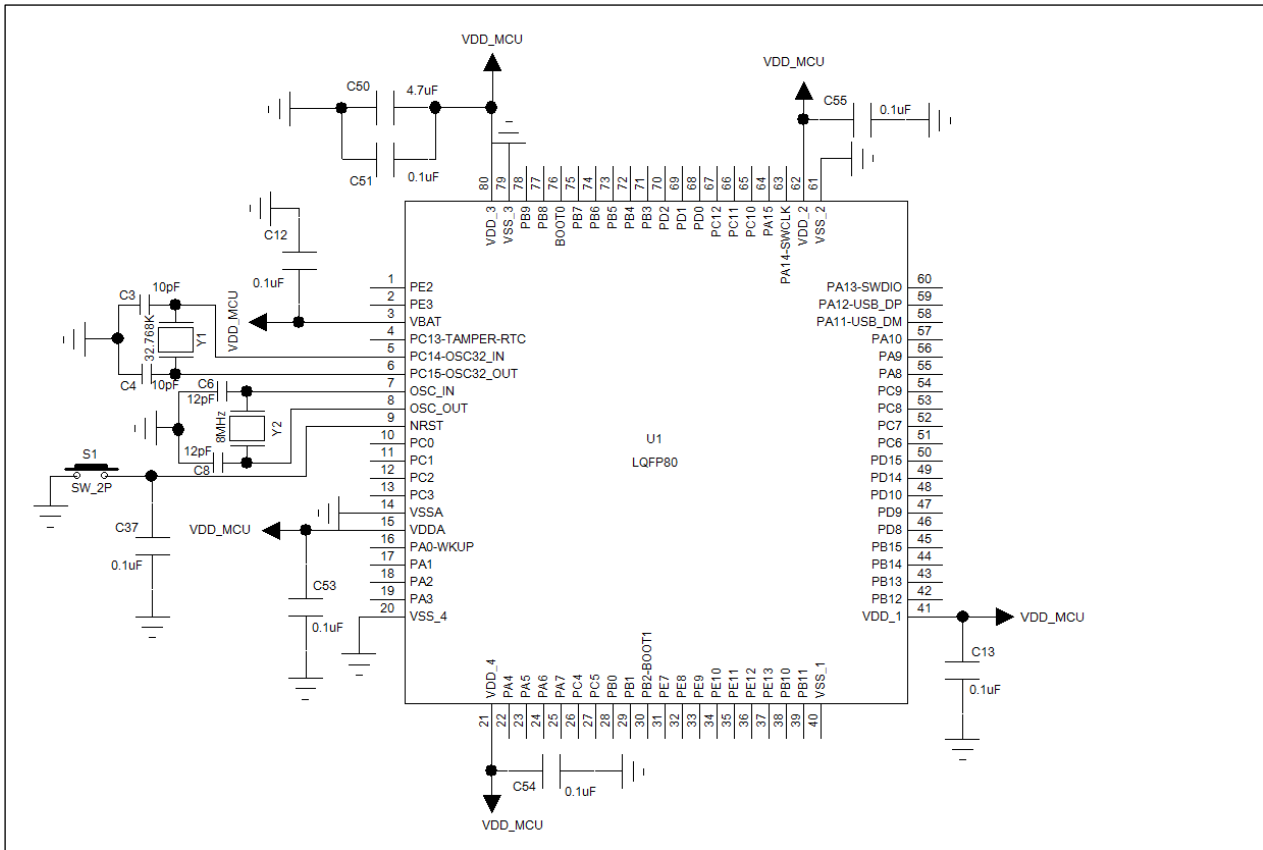

### 3.3 LQFP64

Figure 3-3 LQFP64 Package Minimum System Reference Design Schematic

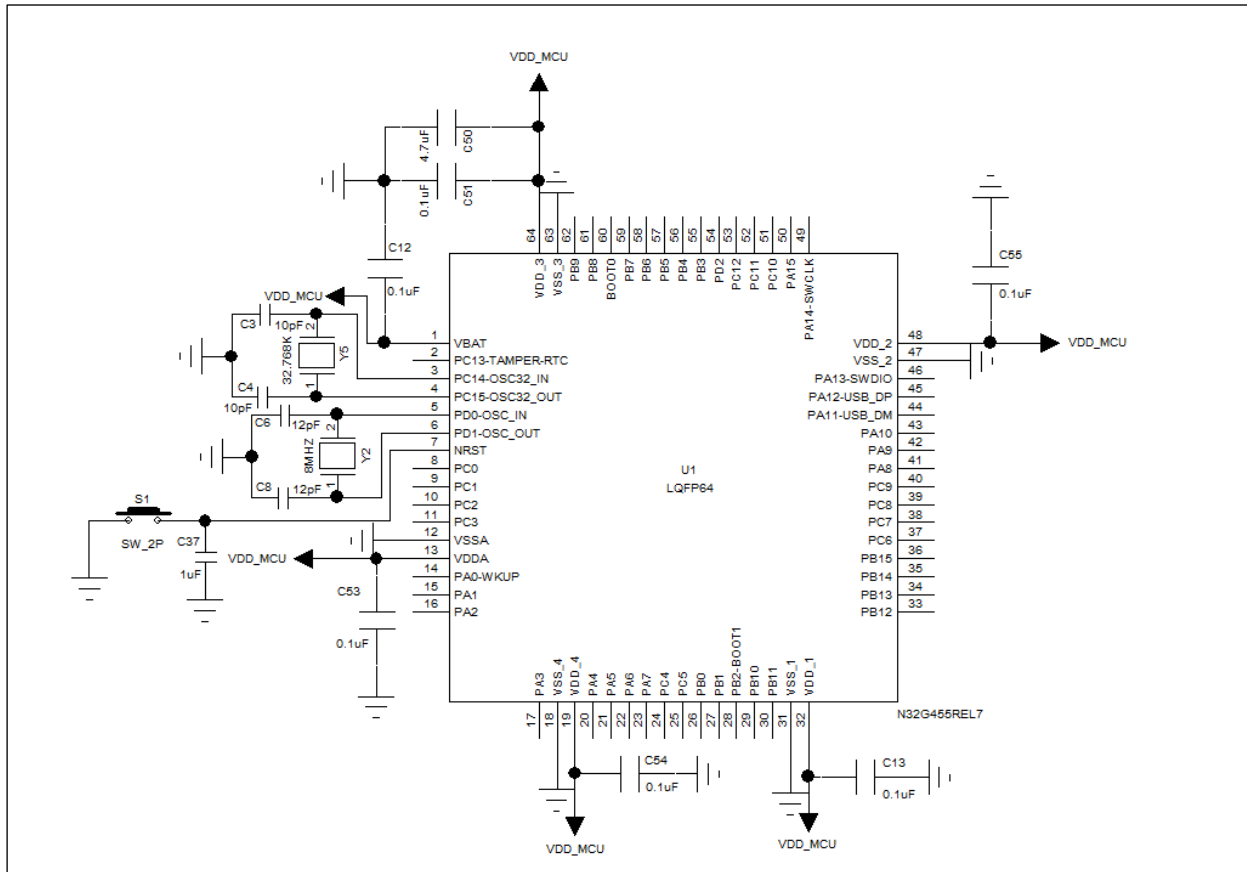

### 3.4 LQFP48

Figure 3-4 LQFP48 Package Minimum System Reference Design Schematic

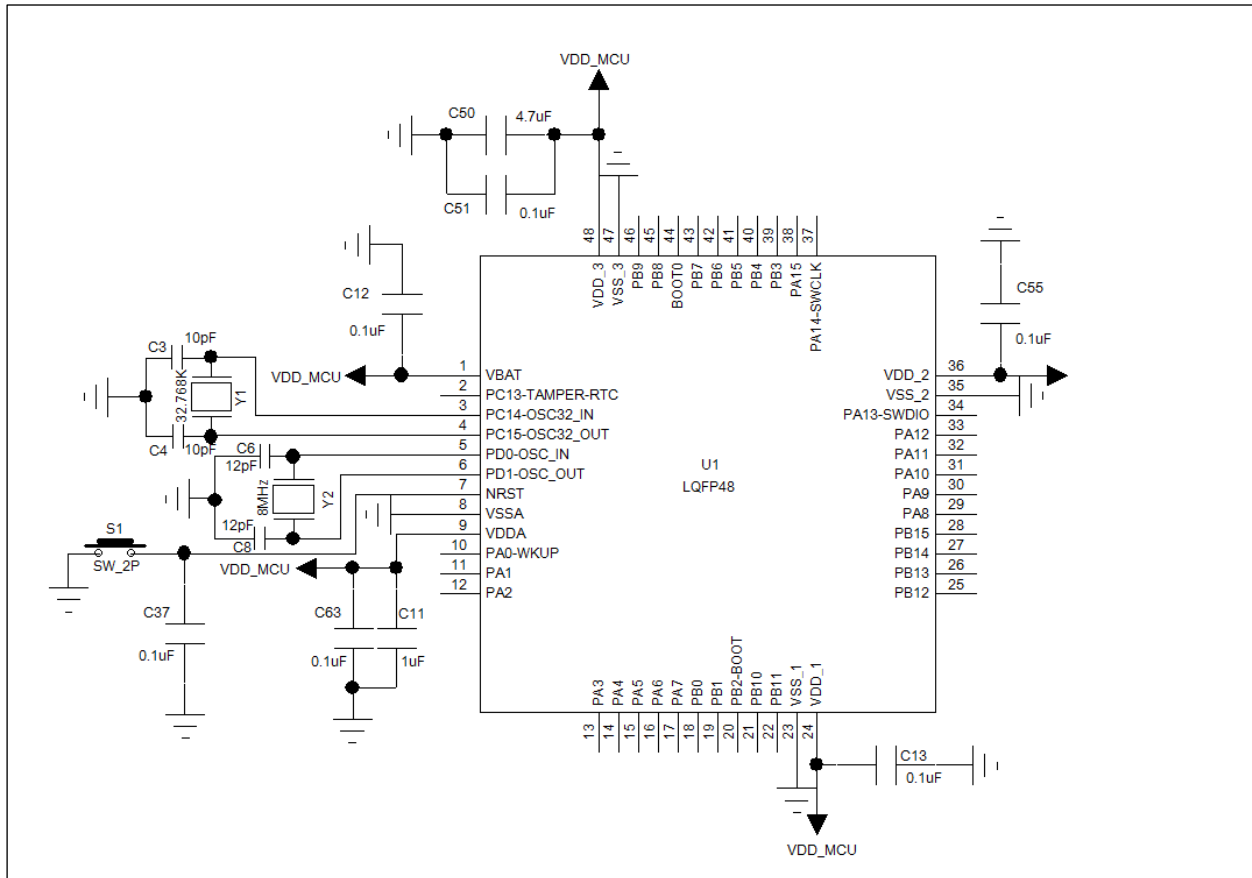

### 3.5 LQFP32

Figure 3-5 LQFP32 Package Minimum System Reference Design Schematic



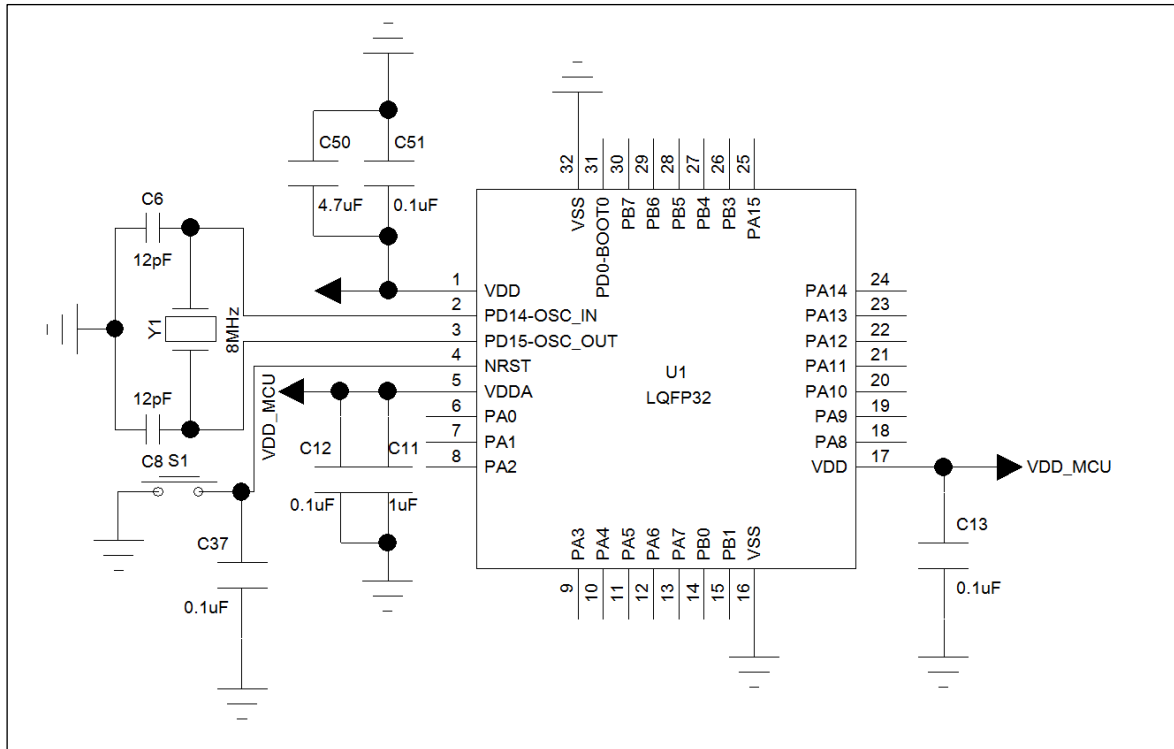

### 3.6 QFN40

Figure 3-6 QFN40 Package Minimum System Reference Design Schematic

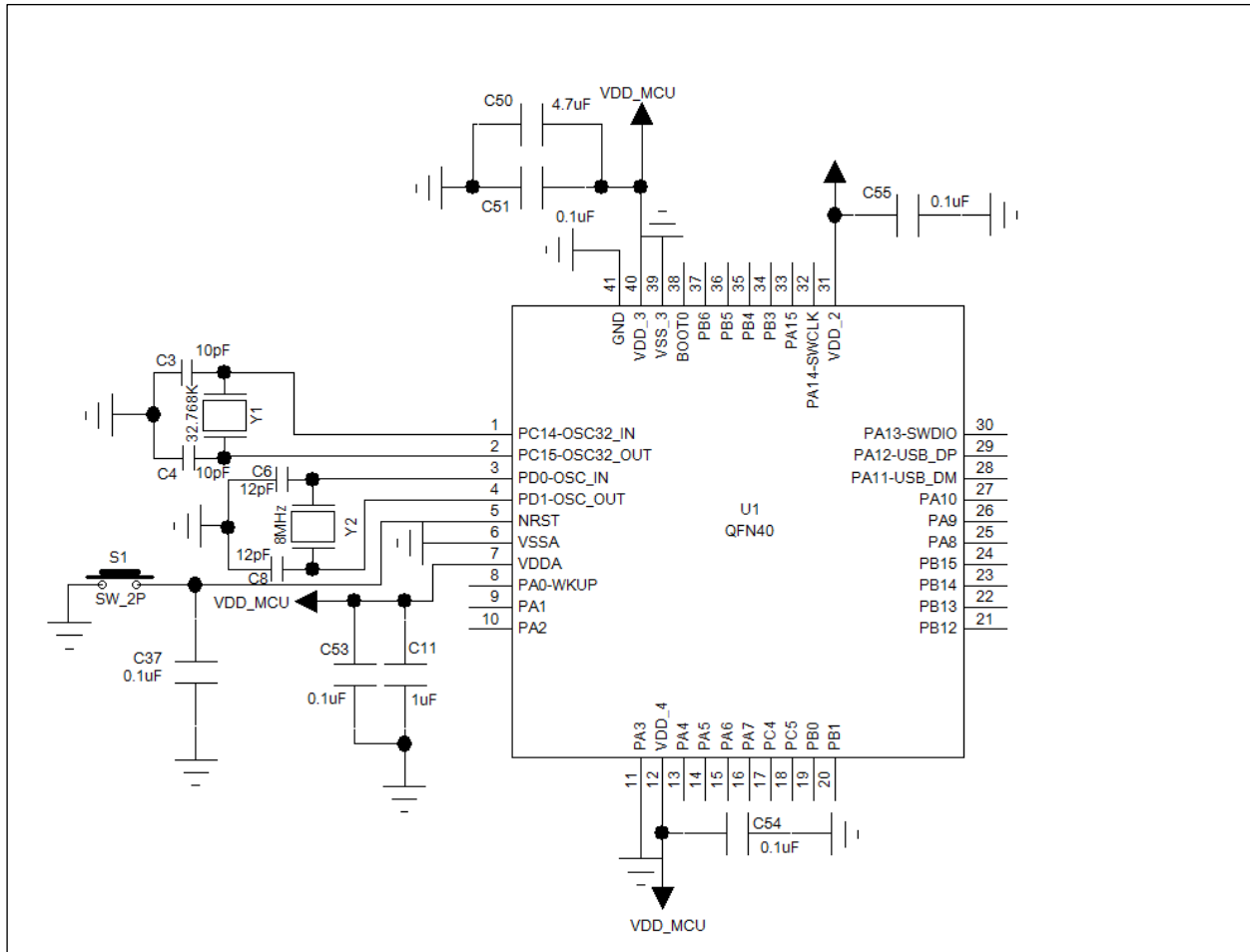

### 3.7 QFN32

Figure 3-7 QFN32 Package Minimum System Reference Design Schematic

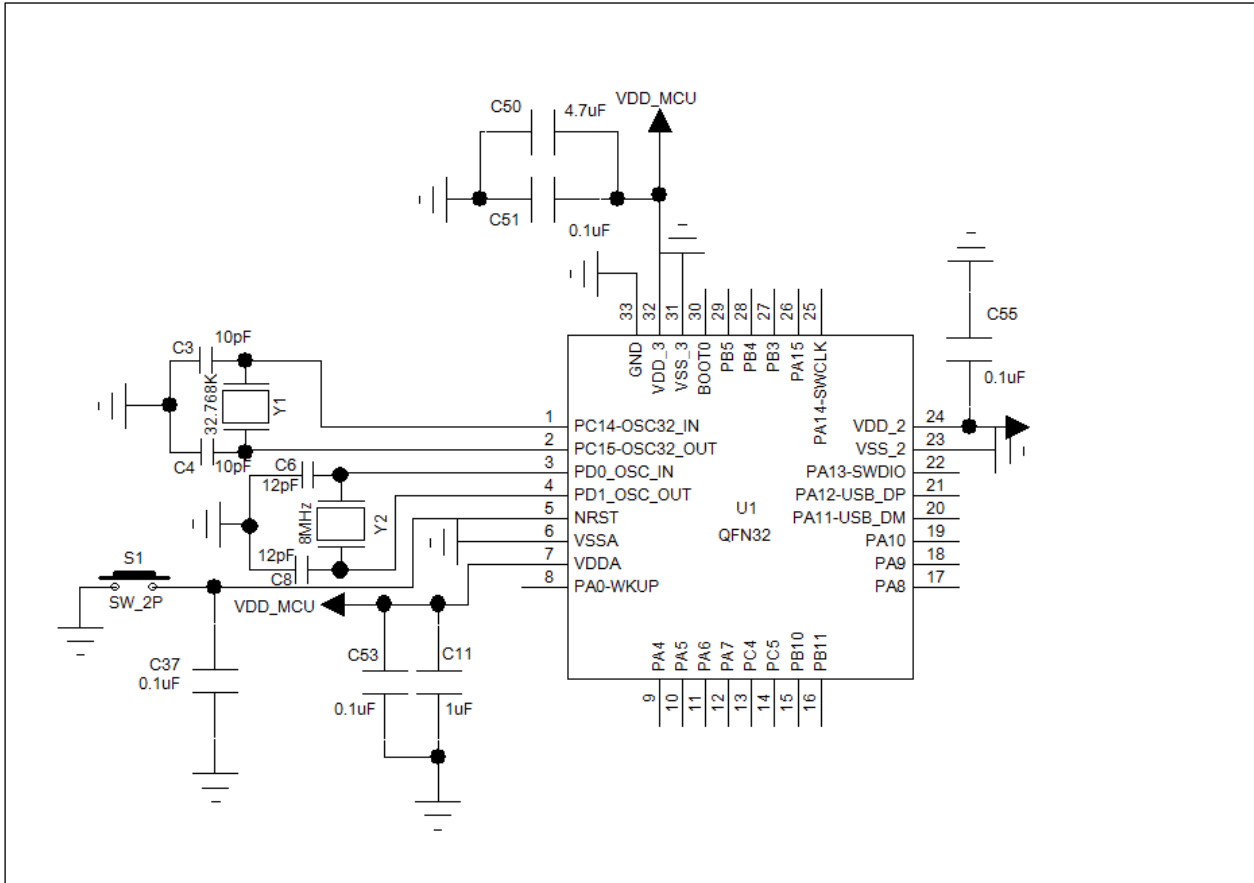

**Error! Reference source not found.** to **Error! Reference source not found.** are the schematic diagrams of the minimum system reference design of each package of the N32G45X/N32G4FR series, which mainly reflect the design of power supply decoupling capacitors, clocks, reset circuits, etc. The clock circuit depends on the user's design, and the chip supports internal high-speed and low-speed clocks available to the user for selection.

### 4. PCB LAYOUT Reference

Figure 4-1 LQFP100 Package PCB LAYOUT Reference Diagram

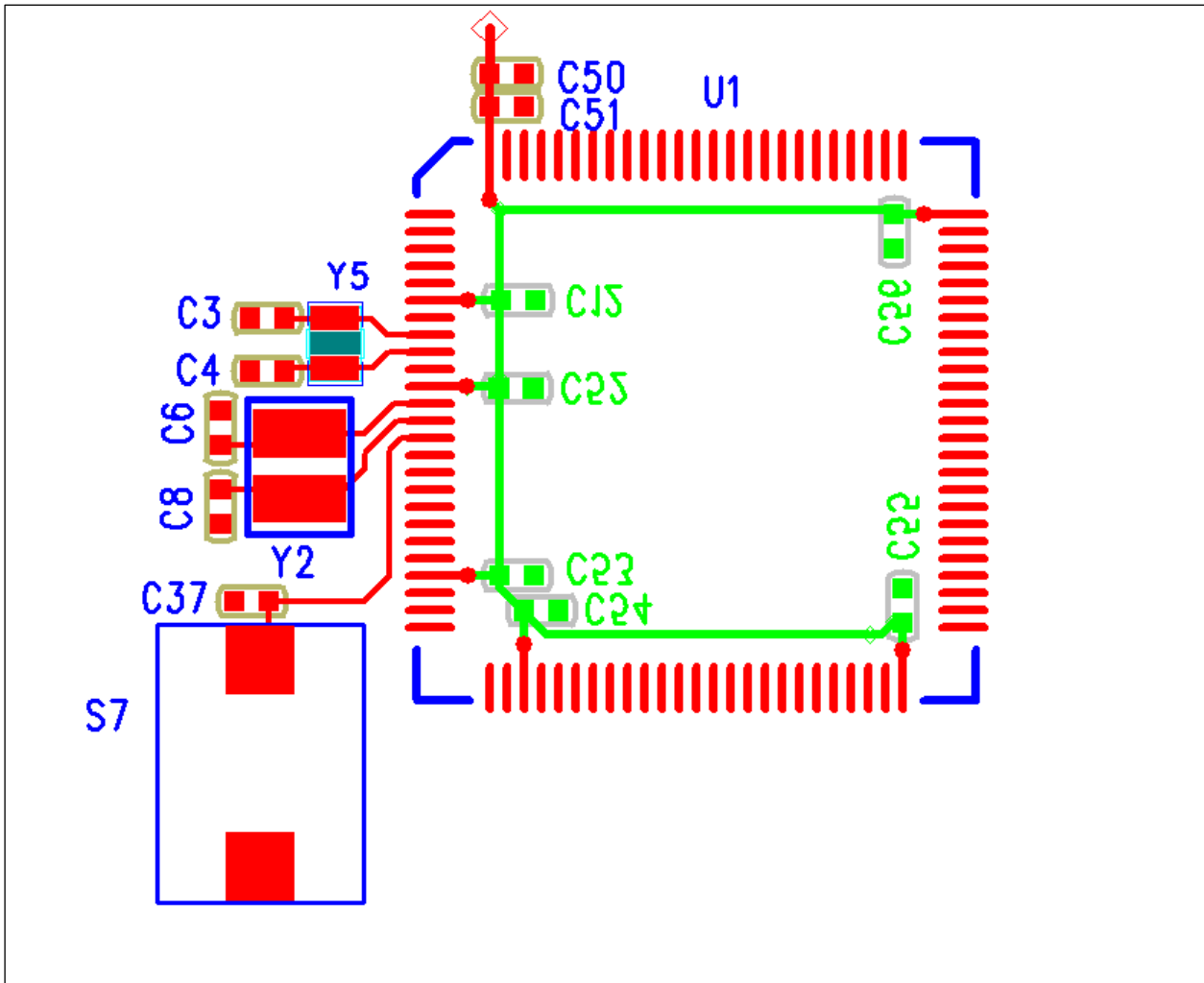

During PCB LAYOUT design, decoupling capacitors need to be placed near each power pin. The external crystals and traces of the HSE and LSE should be grounded as much as possible. The area below the crystals close to the crystals also needs to be grounded, and no signal lines can pass through them to prevent the signal lines from interfering with the crystal signals.

## 5. Typical Fault Analysis

The common problems and analysis methods encountered by customers in the process of using the chip are described as follows.

### 5.1 Short Circuit Between Power Pins And Ground

#### Problem Description:

The VDD pin of the chip is short-circuited with the GND test, and the chip is abnormally hot after power-on.

#### Problem check:

- 1) Whether the VDD decoupling capacitor has insufficient voltage tolerance to cause the capacitor to break down and short circuit.
- 2) When the product starts up, whether the VDD voltage exceeds the specified maximum value.
- 3) Whether there is an overshoot voltage exceeding the maximum value of VDD during the operation of the product.
- 4) In the process of production and use, whether there is static electricity that causes chip damage.

### 5.2 GPIO Damage

#### Problem Description:

The chip GPIO cannot output a high level or a low level normally, the GPIO is used as an input to detect the level error, the VIH or VIL test value is abnormal, and the pin impedance is abnormal.

#### Problem check:

- 1) Whether the external input voltage to the chip GPIO exceeds the maximum value, such as the 5V-tolerant I/O input voltage exceeding 5V.
- 2) In the process of product production and testing, whether there is a high voltage input to the GPIO port.
- 3) In product design, whether there is a high-voltage signal near the GPIO trace coupled to the GPIO input port.
- 4) In the process of production and use, whether there is static electricity that causes chip damage.

### 5.3 ADC Sampling Inaccurate

#### Problem Description:

When sampling the voltage at the ADC input port of the chip, the sampling voltage is inaccurate.

#### Problem check:

Refer to Section 1.7 to confirm whether the hardware and software settings meet the requirements of ADC considerations.

## 6. Version History

Version	Date	Changes
V1.0	2022.4.6	1、 Create documentation
V1.1	2022.6.8	1、 Modified the chapter 1.4 External Clock Circuit (added the precautions for using LSE) 2、 Added chapter 1.5 Startup Pin Connection 3、 Modify the chapter 1.6 Independent ADC Converter (modify the precautions for ADC use) 4、 Added chapter 1.7 IO port power-on pulse processing 5、 Add chapter 1.8 IO withstand voltage value 6、 Add Chapter 1.9 Anti-static Design 7、 Added chapter 1.10 Debug Interface 8、 Added chapter 1.11 BOOT serial port 9、 Add Chapter 5 Typical Failure Analysis

## 7. Disclaimer

This document is the exclusive property of NSING TECHNOLOGIES PTE. LTD.(Hereinafter referred to as NSING).

This document, and the product of NSING described herein (Hereinafter referred to as the Product) are owned by NSING under the laws and treaties of Republic of Singapore and other applicable jurisdictions worldwide. The intellectual properties of the product belong to Nations Technologies Inc. and Nations Technologies Inc. does not grant any third party any license under its patents, copyrights, trademarks, or other intellectual property rights. Names and brands of third party may be mentioned or referred thereto (if any) for identification purposes only. NSING reserves the right to make changes, corrections, enhancements, modifications, and improvements to this document at any time without notice. Please contact NSING and obtain the latest version of this document before placing orders.

Although NATIONS has attempted to provide accurate and reliable information, NATIONS assumes no responsibility for the accuracy and reliability of this document. It is the responsibility of the user of this document to properly design, program, and test the functionality and safety of any application made of this information and any resulting product. In no event shall NATIONS be liable for any direct, indirect, incidental, special, exemplary, or consequential damages arising in any way out of the use of this document or the Product.

NATIONS Products are neither intended nor warranted for usage in systems or equipment, any malfunction or failure of which may cause loss of human life, bodily injury or severe property damage. Such applications are deemed, 'Insecure Usage'. Insecure usage includes, but is not limited to: equipment for surgical implementation, atomic energy control instruments, airplane or spaceship instruments, all types of safety devices, and other applications intended to supporter sustain life. All Insecure Usage shall be made at user's risk. User shall indemnify NATIONS and hold NATIONS harmless from and against all claims, costs, damages, and other liabilities, arising from or related to any customer's Insecure Usage Any express or implied warranty with regard to this document or the Product, including, but not limited to. The warranties of merchantability, fitness for a particular purpose and non-infringement are disclaimed to the fullest extent permitted by law. Unless otherwise explicitly permitted by NATIONS, anyone may not use, duplicate, modify, transcribe or otherwise distribute this document for any purposes, in whole or in part.