

N32G457 Series Errata Sheet

CONTENTS

1 Errata list.....	4
2 Power control (PWR)	6
2.1 Stop2 Mode wakes up	6
3 Reset and Clock Control (RCC)	7
3.1 System Timer (SysTick).....	7
4 GPIO and AFIO.....	8
4.1 SPI1 slave mode, USART2 synchronous mode	8
4.2 SPI1 master mode, USART2 synchronous mode	8
4.3 SPI2 slave mode, USART3 synchronous mode	8
4.4 SPI2 master mode, USART3 synchronous mode	8
5 Analog/Digital Conversion (ADC).....	10
5.1 ADC data left-align.....	10
5.2 ADC analog watchdog	10
5.3 ADC injection channels trigger regular channel conversions	10
5.4 The master ADC conversion is started under the influence of the slave ADC conversion.....	11
5.5 Adjacent ADC data registers are affected	11
6 Serial Peripheral Interface (SPI).....	12
6.1 SPI interface.....	12
6.1.1 SPI baud rate setting.....	12
6.1.2 CRC check from mode	12
6.2 I2S interface	13
6.2.1 PCM long frame mode	13
7 I2C interface.....	14
7.1 Software events that must be managed before the current byte transfer	14
7.2 Considerations when reading single or double bytes at a time	14
7.3 Use DMA in conjunction with other peripherals	15
8 Universal Synchronous asynchronous Receiver (USART).....	16
8.1 Check error flag	16
8.2 RTS hardware flow control.....	16

9 Debug Interface (DBG)	17
9.1 The Debug registers	17
10 Timer (TIM)	18
10.1 The timer repeats capture detection	18
11 Real Time Clock (RTC)	19
11.1 RTC prescaler	19
11.2 RTC calibration.....	19
11.3 RTC clock.....	19
11.4 RTC wake up	19
12 Chip screen printing and version description	20
13 Version history	21
14 NOTICE	Error! Bookmark not defined.

1 Errata list

Table 1-1 Overview of errata

Errata link		Chip version	
		Version B	
Chapter 2: Power Control (PWR)	Section 2.1: Stop2 Mode wakes up	•	
Chapter 3: Reset and Clock Control (RCC)	Section 3.1: System Timer (SysTick)	•	
Chapter 4: GPIO and AFIO	Section 4.1: SPI1 slave mode, USART2 synchronization mode	•	
	Section 4.2: SPI1 master mode, USART2 synchronous mode	•	
	Section 4.3: SPI2 slave mode, USART3 synchronization mode	•	
	Section 4.4: SPI2 master mode, USART3 synchronization mode	•	
Chapter 5: Analog/Digital Conversion (ADC)	Section 5.1: ADC data left-align	•	
	Section 5.2: ADC analog watchdog	•	
	Section 5.3: ADC injection channels trigger regular channel conversions	•	
	Section 5.4: The master ADC conversion is started under the influence of the slave ADC conversion	•	
	Section 5.5: Adjacent ADC data registers are affected	•	
Chapter 6: Serial Peripheral Interface (SPI)	Section 6.1: SPI Interface	Section 6.1.1: SPI baud rate setting	•
		Section 6.1.2: CRC check from mode	•
	Section 6.2: I2S interface	Section 6.2.1: PCM long frame mode	•
Chapter 7: I2C interface	Section 7.1: Software events that must be managed before the current byte transfer	•	

	Section 7.2: Considerations when reading single or double bytes at a time	•
	Section 7.3: Use DMA in conjunction with other peripherals	•
Chapter 8: Universal Synchronous Asynchronous Receiver (USART)	Section 8.1: Check error flag	•
	Section 8.2: RTS hardware flow control	•
Chapter 9: Debug Interface (DBG)	Section 9.1: The Debug registers	•
Chapter 10: Timer (TIM)	Section 10.1: The timer repeats capture detection	•
Chapter 11: Real Time Clock (RTC)	Section 11.1: RTC prescaler	•
	Section 11.2: RTC calibration	•
	Section 11.3: RTC clock	•
	Section 11.4: RTC wake up	•

2 Power control (PWR)

2.1 Stop2 Mode wakes up

Description

MCU is in Stop2 mode. If NRST reset occurs at the same time when MCU is awakened, NRST cannot reset MCU, awakening takes precedence and MCU will respond to awakening first.

Workaround

Avoid NRST resetting the MCU at the same time of awakening, or NRST resetting the MCU twice in a row in a scenario where NRST resetting is required.

3 Reset and Clock Control (RCC)

3.1 System Timer (SysTick)

Description

Set the CLKSOURCE control bit of the SysTick control register. If the External Reference Clock (STCLK) is set as the clock source, MCU cannot be woken up. When Use-core-clock is set as the clock source, the clock works normally.

Workaround

Set the Use-core-clock as the clock source.

4 GPIO and AFIO

4.1 SPI1 slave mode, USART2 synchronous mode

Description

SPI1 and USART2 clocks are enabled, pin PA4 is set to multiplexed output. SPI1 works in slave mode and is in NSS software mode (SSMEN=1, SSEL=0), USART2 clock working in synchronous mode cannot be emitted.

Workaround

None

4.2 SPI1 master mode, USART2 synchronous mode

Description

SPI1 and USART2 clocks are enabled, pin PA4 is set to multiplexed output. SPI1 works in master mode and is in NSS software mode (SSMEN=1, SSEL=0), USART2 clock working in synchronous mode cannot be emitted.

Workaround

Enable the SSOEN bit in SPI1 master mode.

4.3 SPI2 slave mode, USART3 synchronous mode

Description

SPI2 and USART3 clocks are enabled, pin PB12 is set to multiplexed output. SPI2 works in slave mode and is in NSS software mode (SSMEN=1, SSEL=0), USART3 clock working in synchronous mode cannot be emitted.

Workaround

None

4.4 SPI2 master mode, USART3 synchronous mode

Description

SP2 and USART3 clocks are enabled and pin PB12 is set to reuse output. SPI2 working in master mode and in NSS software mode (SSMEN=1, SSEL=0), USART3 clock working in synchronous mode cannot be emitted

Workaround

Enable the SSOEN bit in SPI2 master mode.

5 Analog/Digital Conversion (ADC)

5.1 ADC data left-align

Description

ADC single conversion mode, non-12bit precision and left aligned, the software triggers the conversion rule channel, in the ADC_DAT register, the highest invalid bit is 1.

Workaround

Retain only valid data bits or use right-aligned mode.

5.2 ADC analog watchdog

Description

When the ADC works in independent mode and converts once and the accuracy is not 12bit, the analog watchdog function is enabled, and the software triggers the conversion rule channel/injection channel. The effective bits of the analog watchdog high threshold value are set equal to the value of the ADC data register. When the invalid bits are all 0, the analog watchdog may be triggered by mistake.

Workaround

In this case, the highest position 1 of the invalid bit of the simulated watchdog high threshold is not triggered.

5.3 ADC injection channels trigger regular channel conversions

Description

When the software triggers the injection channel conversion, the regular channel conversion may be started. As a result, data is generated in ADC_DAT, and the corresponding status bit of ADC_STS regular channel conversion will be set.

Workaround

Flag bits and data generated by regular channels are ignored.

5.4 The master ADC conversion is started under the influence of the slave

ADC conversion

Description:

ADC works in dual ADC mode and synchronous injection mode. Only the software triggers the regular channel conversion of the primary ADC, the regular channel conversion of the secondary ADC, and the lower 16 bits from ADC_DAT are merged into the higher 16 bits of the primary ADC_DAT

Workaround:

None

5.5 Adjacent ADC data registers are affected

Description:

Independent working mode, software triggers ADC4/2 regular channel conversion, ADC4/2 DAT register 16 bits lower content will be merged into ADC3/1 DAT register 16 bits higher.

Workaround:

None

6 Serial Peripheral Interface (SPI)

6.1 SPI interface

6.1.1 SPI baud rate setting

Description

When the baud rate control bit (BR[2:0]) is set to $f_{PLCK}/2$ in SPI master mode, CRC check will fail.

Workaround

In this case, avoid setting baud rate control bit (BR[2:0]) to $f_{PLCK}/2$.

6.1.2 CRC check from mode

Description

The SPI operates in slave mode and CRC verification is enabled. Even if the NSS pin is high, CRC calculations are performed whenever the SPI receives a clock signal

Workaround

Before using THE CRC check, clear the CRC data register to synchronize the CRC check between the primary and secondary devices

The clearing steps are as follows:

1. Reset the SPI enable bit (set 0)
2. Reset the CRC check bit (set 0)
3. Reset the CRC check bit (set 1)
4. Set the SPI enable bit (set 1)

6.2 I2S interface

6.2.1 PCM long frame mode

Description

When the I2S work in master mode, PCM long frame mode, and the data format is “32bit” or “16bit extended to 32bit”, the WS signal is cycles every 16bit instead of 32bit.

Workaround

When I2S is in master mode and long frame mode must be used, 16bit data mode should be used.

7 I2C interface

7.1 Software events that must be managed before the current byte transfer

Description

When EV7, EV7_1, EV6_1, EV6, EV2, EV8, and EV3 events occur, the events must be processed before the current byte is transferred. Otherwise, one more byte may be read, duplicate data may be read, or data may be lost.

If the data N-1 is not read by the software before the stop signal is generated, the data N in the shift register is corrupted (moved one bit to the left).

Workaround

1. Use DMA when transferring more than one byte using I2C
2. When using I2C interrupts, the interrupt priority is set to the highest priority of the application
3. When the read data reaches the N-1 byte:
 - a) Check BSF is 1
 - b) Set SCL to GPIO open miss output and set it to 0
 - c) Set STOPGEN to 1
 - d) Read the N-1 byte
 - e) Set SCL to open/miss output mode for I2C multiplexing
 - f) Read the last byte

7.2 Considerations when reading single or double bytes at a time

Description

In host read mode, data read errors may occur when the bytes read are single or double bytes.

Workaround

1. Single byte reading:
 - a) Upon receipt of ADDR_F
 - b) Set the ACKEN bit to 0
 - c) Clear the ADDR_F bit (by reading STS1 and then STS2)
 - d) Set STOPGEN to 1

- e) Read one byte of data.
- 2. Double-byte read:
 - a) Upon receipt of ADDRf
 - b) Set the ACKPOS bit to 1
 - c) Clear the ADDRf bit (by reading STS1 and then STS2)
 - d) Set the ACKEN bit to 0
 - e) The BSF level was 1
 - f) Set STOPGEN to 1
 - g) Read two bytes of data in a row

7.3 Use DMA in conjunction with other peripherals

Description

If other peripherals are using the same DMA controller during DMA communication, I2C communication will be abnormal

Workaround

- 1. Use different DMA controllers.
- 2. I2C turns off DMA for other peripherals during DMA communication.

8 Universal Synchronous asynchronous Receiver (USART)

8.1 Check error flag

Description

During the receipt of a byte of data, a checksum error is detected before the stop bit is received, and the checksum error flag bit is set, during which the checksum error flag bit cannot be cleared by software (read status register, read data register again). If checksum interrupt is enabled, the checksum interrupt handler will be entered several times.

Workaround

The read buffer flag bit is set, and the error flag bit operation is performed after the data is received.

If checksum error interrupt is enabled, to avoid entering the interrupt processing function for multiple times, the checksum error interrupt is disabled when entering the checksum error interrupt for the first time. After receiving data, the checksum error interrupt is enabled again.

8.2 RTS hardware flow control

Description

When the RTS hardware flow control is enabled, the USART receives a frame of data. When the first byte of data is received, the RTS signal is automatically pulled up. If the first byte of data is not read out of the data register in time, the RTS signal is pulled down again after the next byte of data is received, and the USART waits for the next frame of data to be received.

Workaround

Read the data from the data register in time before receiving the next new data.

9 Debug Interface (DBG)

9.1 The Debug registers

Description

The DBGMCU_IDCODE debug register can only be accessed in debug mode (not by user programs), and the value returned by reading in user mode is 0xFF.

Workaround

Avoid using IDCODE in user applications.

10 Timer (TIM)

10.1 The timer repeats capture detection

Description

When an input capture is generated, if a new input capture is generated during reading of the TIMx_CCDA Tx (capture/compare register X) (the read operation automatically clears the capture flag bit), CCxOCF(capture/compare X repeat capture flag) may still be set.

Workaround

None

11 Real Time Clock (RTC)

11.1 RTC prescaler

Description

The RTC asynchronous prescaler coefficient and the synchronous prescaler coefficient cannot be set to 0, otherwise it will easily cause the RTC pre-allocation to fail.

Workaround

Avoid setting the DIVA[6:0](asynchronous pre-band) and DIVS[14:0](synchronous pre-band) registers of TRC_PRE to 0.

11.2 RTC calibration

Description

If DIVA is not 128/64/32/16/8 during RTC automatic calibration (RTC_CALIB register CP position 1), the RTC automatic calibration will not succeed.

Workaround

If RTC automatic calibration is required, the DIVA coefficient should be 128/64/32/16/8.

11.3 RTC clock

Description

If NRST reset occurs during RTC operation, RTC timing will be suspended during the reset.

Workaround

None

11.4 RTC wake up

Description

The RTC module cannot wake-up periodically in Standby mode.

Workaround

Use RTC alarm to wake-up Standby mode.

12 Chip screen printing and version description

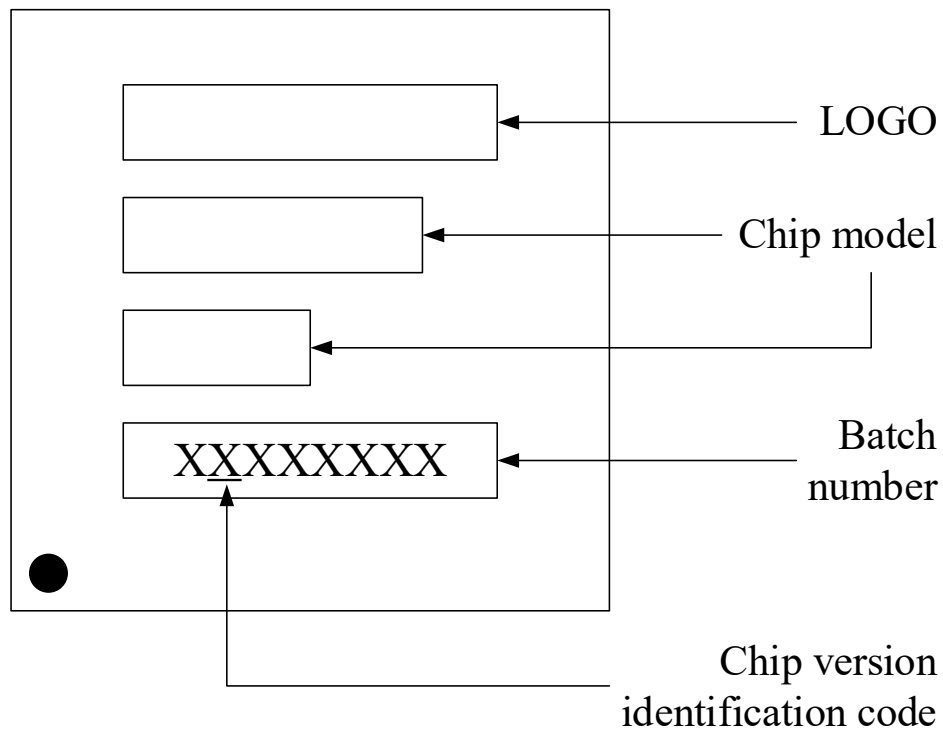

13 Version History

Version	Date	Changes
V1.0	2021.09.17	Initial release
V1.1.0	2022.09.02	Added the RTC wake Corrigendum

14 Disclaimer

This document is the exclusive property of NSING TECHNOLOGIES PTE. LTD. (Hereinafter referred to as NSING).

This document, and the product of NSING described herein (Hereinafter referred to as the Product) are owned by NSING under the laws and treaties of Republic of Singapore and other applicable jurisdictions worldwide. The intellectual properties of the product belong to Nations Technologies Inc. and Nations Technologies Inc. does not grant any third party any license under its patents, copyrights, trademarks, or other intellectual property rights. Names and brands of third party may be mentioned or referred thereto (if any) for identification purposes only. NSING reserves the right to make changes, corrections, enhancements, modifications, and improvements to this document at any time without notice. Please contact NSING and obtain the latest version of this document before placing orders.

Although NATIONS has attempted to provide accurate and reliable information, NATIONS assumes no responsibility for the accuracy and reliability of this document. It is the responsibility of the user of this document to properly design, program, and test the functionality and safety of any application made of this information and any resulting product. In no event shall NATIONS be liable for any direct, indirect, incidental, special, exemplary, or consequential damages arising in any way out of the use of this document or the Product.

NATIONS Products are neither intended nor warranted for usage in systems or equipment, any malfunction or failure of which may cause loss of human life, bodily injury or severe property damage. Such applications are deemed, 'Insecure Usage'. Insecure usage includes, but is not limited to: equipment for surgical implementation, atomic energy control instruments, airplane or spaceship instruments, all types of safety devices, and other applications intended to supporter sustain life. All Insecure Usage shall be made at user's risk. User shall indemnify NATIONS and hold NATIONS harmless from and against all claims, costs, damages, and other liabilities, arising from or related to any customer's Insecure Usage Any express or implied warranty with regard to this document or the Product, including, but not limited to. The warranties of merchantability, fitness for a particular purpose and non-infringement are disclaimed to the fullest extent permitted by law. Unless otherwise explicitly permitted by NATIONS, anyone may not use, duplicate, modify, transcribe or otherwise distribute this document for any purposes, in whole or in part.