

**N32G031 series**

**32-bit ARM Cortex<sup>®</sup>-M0 microcontroller**

User manual

# Contents

|  |           |
|--|-----------|
| <b>1 ABBREVIATIONS IN THE TEXT .....</b>               | <b>27</b> |
| 1.1 LIST OF ABBREVIATIONS FOR REGISTERS.....           | 27        |
| 1.2 AVAILABLE PERIPHERALS .....                        | 27        |
| <b>2 MEMORY AND BUS ARCHITECTURE .....</b>             | <b>28</b> |
| 2.1 SYSTEM ARCHITECTURE.....                           | 28        |
| 2.1.1 Bus Architecture .....                           | 28        |
| 2.1.2 Bus Address Mapping.....                         | 30        |
| 2.1.3 Boot Management.....                             | 32        |
| 2.2 MEMORY SYSTEM.....                                 | 33        |
| 2.2.1 FLASH Specification.....                         | 33        |
| 2.2.2 SRAM.....  | 46        |
| 2.2.3 FLASH Register Description.....                  | 46        |
| <b>3 POWER CONTROL (PWR).....</b>                      | <b>53</b> |
| 3.1 GENERAL DESCRIPTION .....                          | 53        |
| 3.1.1 Power Supply.....                                | 53        |
| 3.1.2 Power Supply Supervisor.....                     | 54        |
| 3.1.3 NRST .....                                       | 56        |
| 3.2 POWER MODES.....                                   | 56        |
| 3.2.1 LPRUN Mode.....                                  | 58        |
| 3.2.2 SLEEP Mode .....                                 | 59        |
| 3.2.3 STOP Mode.....                                   | 59        |
| 3.2.4 PD Mode.....                                     | 60        |
| 3.3 DEBUG SUPPORT .....                                | 60        |
| 3.3.1 Low Power Mode Debug Support .....               | 61        |
| 3.3.2 Peripheral Debug Support.....                    | 61        |
| 3.4 PWR REGISTERS.....                                 | 61        |
| 3.4.1 PWR Register Overview.....                       | 61        |
| 3.4.2 Power Control Register (PWR_CTRL) .....          | 62        |
| 3.4.3 Power Control Status Register (PWR_CTRLSTS)..... | 63        |
| 3.4.4 Power Control Register 2 (PWR_CTRL2) .....       | 64        |
| 3.4.5 Power Control Register 3 (PWR_CTRL3) .....       | 65        |
| 3.4.6 Power Control Register 4 (PWR_CTRL4) .....       | 65        |
| 3.4.7 Power Control Register 5 (PWR_CTRL5) .....       | 66        |
| 3.4.8 Power Control Register 6 (PWR_CTRL6) .....       | 66        |
| 3.4.9 Debug Control Register (Dbg_CTRL).....           | 67        |
| <b>4 RESET AND CLOCK CONTROL (RCC) .....</b>           | <b>70</b> |
| 4.1 RESET CONTROL UNIT.....                            | 70        |

|            |   |            |
|------------|---|------------|
| 4.1.1      | Power Reset .....   | 70         |
| 4.1.2      | System Reset.....   | 70         |
| <b>4.2</b> | <b>CLOCK CONTROL UNIT .....</b>                             | <b>72</b>  |
| 4.2.1      | Clock Tree Diagram.....                                     | 74         |
| 4.2.2      | HSE Clock .....   | 74         |
| 4.2.3      | HSI Clock .....   | 75         |
| 4.2.4      | PLL Clock.....  | 76         |
| 4.2.5      | LSE Clock.....  | 76         |
| 4.2.6      | LSI Clock.....  | 77         |
| 4.2.7      | System Clock (SYSCLK) Selection .....                       | 77         |
| 4.2.8      | Clock Security System (CLKSS).....                          | 77         |
| 4.2.9      | RTC Clock .....   | 78         |
| 4.2.10     | Watchdog Clock.....   | 78         |
| 4.2.11     | LPUART Clock .....  | 78         |
| 4.2.12     | LPTIME Clock .....  | 78         |
| 4.2.13     | Microcontroller Clock Output(MCO).....                      | 78         |
| <b>4.3</b> | <b>RCC REGISTERS .....</b>                                  | <b>79</b>  |
| 4.3.1      | RCC Register Overview .....                                 | 79         |
| 4.3.2      | Clock Control Register (RCC_CTRL).....                      | 80         |
| 4.3.3      | Clock Configuration Register (RCC_CFG).....                 | 81         |
| 4.3.4      | Clock Interrupt Register (RCC_CLKINT).....                  | 84         |
| 4.3.5      | APB2 Peripheral Reset Register (RCC_APB2PRST) .....         | 87         |
| 4.3.6      | APB1 Peripheral Reset Register (RCC_APB1PRST) .....         | 88         |
| 4.3.7      | AHB Peripheral Clock Enable Register (RCC_AHBPCCLKEN).....  | 90         |
| 4.3.8      | APB2 Peripheral Clock Enable Register (RCC_APB2PCLKEN)..... | 91         |
| 4.3.9      | APB1 Peripheral Clock Enable Register (RCC_APB1PCLKEN)..... | 92         |
| 4.3.10     | Low Speed Clock Control Register (RCC_LSCTRL) .....         | 94         |
| 4.3.11     | Control/Status Register (RCC_CTRLSTS) .....                 | 95         |
| 4.3.12     | AHB Peripheral Reset Register (RCC_AHBPRST).....            | 97         |
| 4.3.13     | Clock Configuration Register 2(RCC_CFG2).....               | 98         |
| 4.3.14     | EMC Control Register 3 (RCC_EMCCTRL).....                   | 100        |
| <b>5</b>   | <b>GPIO AND AFIO .....</b>                                  | <b>103</b> |
| 5.1        | SUMMARY .....   | 103        |
| 5.2        | FUNCTION DESCRIPTION.....                                   | 104        |
| 5.2.1      | I/O Mode Configuration .....                                | 104        |
| 5.2.2      | Status After Reset.....                                     | 109        |
| 5.2.3      | Individual Bit Setting and Bit Clearing.....                | 109        |
| 5.2.4      | External Interrupt/Wakeup Line.....                         | 109        |
| 5.2.5      | Alternate Function .....                                    | 109        |
| 5.2.6      | I/O Configuration of Peripherals.....                       | 119        |
| 5.2.7      | GPIO Locking Mechanism .....                                | 121        |
| 5.3        | GPIO REGISTERS .....  | 121        |

|          |  |            |
|----------|--|------------|
| 5.3.1    | GPIO Register Overview .....   | 121        |
| 5.3.2    | GPIO Port Mode Description Register (GPIOx_PMODE).....                 | 123        |
| 5.3.3    | GPIO Port Type Definition (GPIOx_POTYPE) .....                         | 124        |
| 5.3.4    | GPIO Slew Rate Configuration Register (GPIOx_SR).....                  | 124        |
| 5.3.5    | GPIO Port Pull-Up/Pull-Down Register (GPIOx_PUPD) .....                | 125        |
| 5.3.6    | GPIO Port Input Data Register (GPIOx_PID).....                         | 125        |
| 5.3.7    | GPIO Port Output Data Register (GPIOx_POD).....                        | 126        |
| 5.3.8    | GPIO Port Bit Set/Clear Register (GPIOx_PBSC).....                     | 126        |
| 5.3.9    | GPIO Port Configuration Lock Register (GPIOx_PLOCK).....               | 127        |
| 5.3.10   | GPIO Alternate Function Low Register (GPIOx_AFL) .....                 | 128        |
| 5.3.11   | GPIO Alternate Function High Register (GPIOx_AFH) .....                | 129        |
| 5.3.12   | GPIO Port Bit Clear Register (GPIOx_PBC) .....                         | 130        |
| 5.3.13   | GPIO Driver Strength Configuration Register (GPIOx_DS).....            | 130        |
| 5.4      | AFIO REGISTERS.....  | 131        |
| 5.4.1    | AFIO Register Overview .....   | 131        |
| 5.4.2    | AFIO Configuration Register (AFIO_CFG).....                            | 131        |
| 5.4.3    | AFIO External Interrupt Configuration Register 1 (AFIO_EXTI_CFG1)..... | 132        |
| 5.4.4    | AFIO External Interrupt Configuration Register 2 (AFIO_EXTI_CFG2)..... | 133        |
| 5.4.5    | AFIO External Interrupt Configuration Register 3 (AFIO_EXTI_CFG3)..... | 134        |
| 5.4.6    | AFIO External Interrupt Configuration Register 4 (AFIO_EXTI_CFG4)..... | 134        |
| <b>6</b> | <b>INTERRUPTS AND EVENTS.....</b>                                      | <b>135</b> |
| 6.1      | NESTED VECTORED INTERRUPT CONTROLLER.....                              | 135        |
| 6.1.1    | Systick Calibration Value Register.....                                | 135        |
| 6.1.2    | Interrupt and Exception Vectors.....                                   | 135        |
| 6.2      | EXTENDED INTERRUPT/EVENT CONTROLLER (EXTI).....                        | 138        |
| 6.2.1    | Introduction.....  | 138        |
| 6.2.2    | Main Features .....  | 138        |
| 6.2.3    | Functional Description.....  | 139        |
| 6.2.4    | EXTI Line Mapping.....   | 141        |
| 6.3      | EXTI REGISTERS .....   | 143        |
| 6.3.1    | EXTI Register Overview .....   | 143        |
| 6.3.2    | Interrupt Mask Register(EXTI_IMASK).....                               | 143        |
| 6.3.3    | Event Mask Register(EXTI_EMASK) .....                                  | 144        |
| 6.3.4    | Rising Edge Trigger Selection Register(EXTI_RT_CFG).....               | 144        |
| 6.3.5    | Falling Edge Trigger Selection Register(EXTI_FT_CFG) .....             | 145        |
| 6.3.6    | Software Interrupt Enable Register(EXTI_SWIE) .....                    | 145        |
| 6.3.7    | Interrupt Request Pending Register(EXTI_PEND) .....                    | 146        |
| 6.3.8    | RTC Timestamp Trigger Source Selection Register (EXTI_TS_SEL).....     | 147        |
| <b>7</b> | <b>DMA CONTROLLER.....</b>   | <b>148</b> |
| 7.1      | INTRODUCTION.....  | 148        |
| 7.2      | MAIN FEATURES .....  | 148        |

|   |            |
|---|------------|
| 7.3 BLOCK DIAGRAM .....   | 149        |
| 7.4 FUNCTION DESCRIPTION.....   | 149        |
| 7.4.1 DMA Operation .....   | 149        |
| 7.4.2 Channel Priority and Arbitration.....                           | 150        |
| 7.4.3 DMA Channels and Number Of Transfers.....                       | 150        |
| 7.4.4 Programmable Data Bit Width, Alignment and Endians.....         | 150        |
| 7.4.5 Peripheral/Memory Address Incrementation .....                  | 152        |
| 7.4.6 Channel Configuration Process.....                              | 152        |
| 7.4.7 Flow Control.....   | 153        |
| 7.4.8 Circular Mode.....  | 153        |
| 7.4.9 Error Management .....  | 154        |
| 7.4.10 Interrupt .....  | 154        |
| 7.4.11 DMA Request Mapping.....                                       | 154        |
| 7.5 DMA REGISTERS .....   | 155        |
| 7.5.1 DMA Register Overview .....                                     | 155        |
| 7.5.2 DMA Interrupt Status Register (DMA_INTSTS).....                 | 156        |
| 7.5.3 DMA Interrupt Flag Clear Register (DMA_INTCLR) .....            | 157        |
| 7.5.4 DMA Channel x Configuration Register (DMA_CHCFGx) .....         | 158        |
| 7.5.5 DMA Channel x Transfer Number Register (DMA_TXNUMx) .....       | 159        |
| 7.5.6 DMA Channel x Peripheral Address Register (DMA_PADDRx).....     | 160        |
| 7.5.7 DMA Channel x Memory Address Register (DMA_MADDRx).....         | 160        |
| 7.5.8 DMA Channel x Channel Request Select Register (DMA_CHSELx)..... | 161        |
| <b>8 CRC CALCULATION UNIT.....</b>                                    | <b>162</b> |
| 8.1 CRC INTRODUCTION.....   | 162        |
| 8.2 CRC MAIN FEATURES .....   | 162        |
| 8.2.1 CRC32 Module.....   | 162        |
| 8.2.2 CRC16 Module.....   | 162        |
| 8.3 CRC FUNCTION DESCRIPTION .....                                    | 163        |
| 8.3.1 CRC32 .....   | 163        |
| 8.3.2 CRC16 .....   | 163        |
| 8.4 CRC REGISTERS.....  | 164        |
| 8.4.1 CRC Register Overview .....                                     | 164        |
| 8.4.2 CRC32 Data Register (CRC_CRC32DAT) .....                        | 164        |
| 8.4.3 CRC32 Independent Data Register (CRC_CRC32IDAT).....            | 164        |
| 8.4.4 CRC32 Control Register (CRC_CRC32CTRL).....                     | 165        |
| 8.4.5 CRC16 Control Register (CRC_CRC16CTRL) .....                    | 165        |
| 8.4.6 CRC16 Input Data Register (CRC_CRC16DAT) .....                  | 166        |
| 8.4.7 CRC Cyclic Redundancy Check Code Register (CRC_CRC16D).....     | 166        |
| 8.4.8 LRC Result Register (CRC_LRC).....                              | 167        |
| <b>9 ADVANCED CONTROL TIMERS (TIM1 AND TIM8) .....</b>                | <b>168</b> |
| 9.1 TIM1 AND TIM8 INTRODUCTION .....                                  | 168        |

|   |     |
|---|-----|
| 9.2 MAIN FEATURES OF TIM1 AND TIM8 .....                    | 168 |
| 9.3 TIM1 AND TIM8 FUNCTION DESCRIPTION .....                | 169 |
| 9.3.1 Time-base Unit .....                                  | 169 |
| 9.3.2 Counter Mode .....                                    | 170 |
| 9.3.3 Repetition Counter .....                              | 175 |
| 9.3.4 Clock Selection .....                                 | 178 |
| 9.3.5 Capture/Compare Channels.....                         | 181 |
| 9.3.6 Input Capture Mode.....                               | 184 |
| 9.3.7 PWM Input Mode.....                                   | 185 |
| 9.3.8 Forced Output Mode.....                               | 186 |
| 9.3.9 Output Compare Mode .....                             | 186 |
| 9.3.10 PWM Mode .....                                       | 188 |
| 9.3.11 One-pulse Mode.....                                  | 191 |
| 9.3.12 Clearing The Ocxref Signal on An External Event..... | 192 |
| 9.3.13 Complementary Outputs and Dead-time Insertion .....  | 193 |
| 9.3.14 Break Function.....                                  | 195 |
| 9.3.15 Debug Mode .....                                     | 196 |
| 9.3.16 TIMx and External Trigger Synchronization.....       | 197 |
| 9.3.17 Timer Synchronization .....                          | 200 |
| 9.3.18 Generating Six-step PWM Output.....                  | 200 |
| 9.3.19 Encoder Interface Mode.....                          | 201 |
| 9.3.20 Interfacing with Hall Sensor .....                   | 204 |
| 9.4 TIMx REGISTER DESCRIPTION(x=1, 8) .....                 | 206 |
| 9.4.1 Register Overview .....                               | 206 |
| 9.4.2 Control Register 1 (TIMx_CTRL1).....                  | 207 |
| 9.4.3 Control Register 2 (TIMx_CTRL2).....                  | 209 |
| 9.4.4 Slave Mode Control Register (TIMx_SMCTRL) .....       | 211 |
| 9.4.5 DMA/Interrupt Enable Registers (TIMx_DINTEN).....     | 214 |
| 9.4.6 Status Registers (TIMx_STS) .....                     | 215 |
| 9.4.7 Event Generation Registers (TIMx_EVTGEN).....         | 217 |
| 9.4.8 Capture/Compare Mode Register 1 (TIMx_CCMOD1).....    | 218 |
| 9.4.9 Capture/Compare Mode Register 2 (TIMx_CCMOD2).....    | 222 |
| 9.4.10 Capture/Compare Enable Registers (TIMx_CCEN).....    | 223 |
| 9.4.11 Counters (TIMx_CNT).....                             | 226 |
| 9.4.12 Prescaler (TIMx_PSC) .....                           | 226 |
| 9.4.13 Auto-reload Register (TIMx_AR).....                  | 227 |
| 9.4.14 Repeat Count Registers (TIMx_REPCNT) .....           | 227 |
| 9.4.15 Capture/Compare Register 1 (TIMx_CCDAT1).....        | 227 |
| 9.4.16 Capture/Compare Register 2 (TIMx_CCDAT2).....        | 228 |
| 9.4.17 Capture/Compare Register 3 (TIMx_CCDAT3).....        | 228 |
| 9.4.18 Capture/Compare Register 4 (TIMx_CCDAT4).....        | 229 |
| 9.4.19 Break and Dead-time Registers (TIMx_BKDT).....       | 230 |

|  |   |            |
|--|---|------------|
| 9.4.20                                       | DMA Control Register (TIMx_DCTRL) .....               | 231        |
| 9.4.21                                       | DMA Transfer Buffer Register (TIMx_DADDR) .....       | 232        |
| 9.4.22                                       | Capture/Compare Mode Registers 3(TIMx_CCMOD3) .....   | 233        |
| 9.4.23                                       | Capture/Compare Register 5 (TIMx_CC DAT5).....        | 233        |
| 9.4.24                                       | Capture/Compare Register 6 (TIMx_CC DAT6).....        | 234        |
| <b>10 GENERAL-PURPOSE TIMER (TIM3) .....</b> |   | <b>235</b> |
| 10.1   | GENERAL-PURPOSE TIMER INTRODUCTION .....              | 235        |
| 10.2   | MAIN FEATURES OF GENERAL-PURPOSE TIMER .....          | 235        |
| 10.3   | GENERAL-PURPOSE TIMERS DESCRIPTION .....              | 236        |
| 10.3.1                                       | Time-base Unit.....                                   | 236        |
| 10.3.2                                       | Counter Mode .....                                    | 237        |
| 10.3.3                                       | Clock Selection .....                                 | 242        |
| 10.3.4                                       | Capture/Compare Channels .....                        | 246        |
| 10.3.5                                       | Input Capture Mode.....                               | 249        |
| 10.3.6                                       | PWM Input Mode .....                                  | 250        |
| 10.3.7                                       | Forced Output Mode.....                               | 251        |
| 10.3.8                                       | Output Compare Mode .....                             | 251        |
| 10.3.9                                       | PWM Mode .....  | 253        |
| 10.3.10                                      | One-pulse Mode .....                                  | 256        |
| 10.3.11                                      | Clearing The Ocxref Signal on An External Event ..... | 257        |
| 10.3.12                                      | Debug Mode .....                                      | 258        |
| 10.3.13                                      | TIMx and External Trigger Synchronization.....        | 258        |
| 10.3.14                                      | Timer Synchronization .....                           | 258        |
| 10.3.15                                      | Encoder Interface Mode.....                           | 262        |
| 10.3.16                                      | Interfacing with Hall Sensor .....                    | 264        |
| 10.4   | TIMX REGISTER DESCRIPTION(X=3).....                   | 264        |
| 10.4.1                                       | Register Overview.....                                | 264        |
| 10.4.2                                       | Control Register 1 (TIMx_CTRL1).....                  | 266        |
| 10.4.3                                       | Control Register 2 (TIMx_CTRL2).....                  | 268        |
| 10.4.4                                       | Slave Mode Control Register (TIMx_SMCTRL) .....       | 269        |
| 10.4.5                                       | DMA/Interrupt Enable Registers (TIMx_DINTEN).....     | 271        |
| 10.4.6                                       | Status Registers (TIMx_STS) .....                     | 273        |
| 10.4.7                                       | Event Generation Registers (TIMx_EVTGEN).....         | 274        |
| 10.4.8                                       | Capture/Compare Mode Register 1 (TIMx_CCMOD1) .....   | 275        |
| 10.4.9                                       | Capture/Compare Mode Register 2 (TIMx_CCMOD2) .....   | 279        |
| 10.4.10                                      | Capture/Compare Enable Registers (TIMx_CCEN).....     | 280        |
| 10.4.11                                      | Counters (TIMx_CNT).....                              | 282        |
| 10.4.12                                      | Prescaler (TIMx_PSC) .....                            | 282        |
| 10.4.13                                      | Auto-reload Register (TIMx_AR) .....                  | 282        |
| 10.4.14                                      | Capture/Compare Register 1 (TIMx_CC DAT1).....        | 282        |
| 10.4.15                                      | Capture/Compare Register 2 (TIMx_CC DAT2).....        | 283        |
| 10.4.16                                      | Capture/Compare Register 3 (TIMx_CC DAT3).....        | 283        |

|           |   |            |
|-----------|---|------------|
| 10.4.17   | Capture/Compare Register 4 (TIMx_CC DAT4).....          | 284        |
| 10.4.18   | DMA Control Register (TIMx_DCTRL).....                  | 285        |
| 10.4.19   | DMA Transfer Buffer Register (TIMx_DADDR).....          | 285        |
| <b>11</b> | <b>BASIC TIMER (TIM6).....</b>                          | <b>287</b> |
| 11.1      | BASIC TIMER INTRODUCTION.....                           | 287        |
| 11.2      | MAIN FEATURES OF BASIC TIMER.....                       | 287        |
| 11.3      | BASIC TIMERS DESCRIPTION.....                           | 287        |
| 11.3.1    | Time-base Unit.....                                     | 287        |
| 11.3.2    | Counter Mode.....                                       | 288        |
| 11.3.3    | Clock Selection.....                                    | 291        |
| 11.3.4    | Debug Mode.....   | 291        |
| 11.4      | TIMx REGISTER DESCRIPTION(x=6).....                     | 291        |
| 11.4.1    | Register Overview.....                                  | 292        |
| 11.4.2    | Control Register 1 (TIMx_CTRL1).....                    | 292        |
| 11.4.3    | DMA/Interrupt Enable Registers (TIMx_DINTEN).....       | 293        |
| 11.4.4    | Status Registers (TIMx_STS).....                        | 294        |
| 11.4.5    | Event Generation Registers (TIMx_EVTGEN).....           | 294        |
| 11.4.6    | Counters (TIMx_CNT).....                                | 295        |
| 11.4.7    | Prescaler (TIMx_PSC).....                               | 295        |
| 11.4.8    | Automatic Reload Register (TIMx_AR).....                | 295        |
| <b>12</b> | <b>LOW POWER TIMER (LPTIM).....</b>                     | <b>297</b> |
| 12.1      | INTRODUCTION.....                                       | 297        |
| 12.2      | MAIN FEATURES.....                                      | 297        |
| 12.3      | BLOCK DIAGRAM.....                                      | 298        |
| 12.4      | FUNCTION DESCRIPTION.....                               | 298        |
| 12.4.1    | LPTIM Clocks and on-off Control.....                    | 298        |
| 12.4.2    | Prescaler.....  | 299        |
| 12.4.3    | Glitch Filter.....                                      | 299        |
| 12.4.4    | Timer Enable.....                                       | 300        |
| 12.4.5    | Trigger Multiplexer.....                                | 300        |
| 12.4.6    | Operating Mode.....                                     | 301        |
| 12.4.7    | Waveform Generation.....                                | 303        |
| 12.4.8    | Register Update.....                                    | 304        |
| 12.4.9    | Counter Mode.....                                       | 305        |
| 12.4.10   | Encoder Mode.....                                       | 305        |
| 12.4.11   | Non-quadrature Encoder Mode.....                        | 307        |
| 12.4.12   | Timeout Function.....                                   | 308        |
| 12.4.13   | LPTIM Interrupts.....                                   | 308        |
| 12.5      | LPTIM REGISTERS.....                                    | 309        |
| 12.5.1    | LPTIM Register Overview.....                            | 309        |
| 12.5.2    | LPTIM Interrupt and Status Register (LPTIM_INTSTS)..... | 310        |



|           |  |            |
|-----------|--|------------|
| 12.5.3    | LPTIM Interrupt Clear Register (LPTIM_INTCLR).....         | 311        |
| 12.5.4    | LPTIM Interrupt Enable Register (LPTIM_INTEN).....         | 312        |
| 12.5.5    | LPTIM Configuration Register (LPTIM_CFG) .....             | 312        |
| 12.5.6    | LPTIM Control Register (LPTIM_CTRL) .....                  | 315        |
| 12.5.7    | LPTIM Compare Register (LPTIM_COMP).....                   | 316        |
| 12.5.8    | LPTIM Auto-reload Register (LPTIM_ARR) .....               | 317        |
| 12.5.9    | LPTIM Counter Register (LPTIM_CNT).....                    | 317        |
| <b>13</b> | <b>INDEPENDENT WATCHDOG (IWDG).....</b>                    | <b>319</b> |
| 13.1      | INTRODUCTION.....  | 319        |
| 13.2      | MAIN FEATURES .....  | 319        |
| 13.3      | FUNCTION DESCRIPTION.....                                  | 320        |
| 13.3.1    | Register Access Protection.....                            | 320        |
| 13.3.2    | Debug Mode .....   | 321        |
| 13.4      | USER INTERFACE .....                                       | 321        |
| 13.4.1    | Operating Process .....                                    | 321        |
| 13.5      | IWDG REGISTERS.....  | 322        |
| 13.5.1    | IWDG Register Overview .....                               | 322        |
| 13.5.2    | IWDG Key Register (IWDG_KEY).....                          | 322        |
| 13.5.3    | IWDG Pre-scaler Register (IWDG_PREDIV) .....               | 322        |
| 13.5.4    | IWDG Reload Register (IWDG_RELV) .....                     | 323        |
| 13.5.5    | IWDG Status Register (IWDG_STS).....                       | 324        |
| <b>14</b> | <b>WINDOW WATCHDOG (WWDG).....</b>                         | <b>324</b> |
| 14.1      | INTRODUCTION.....  | 324        |
| 14.2      | MAIN FEATURES .....  | 325        |
| 14.3      | FUNCTION DESCRIPTION.....                                  | 325        |
| 14.4      | TIMING FOR REFRESH WATCHDOG AND INTERRUPT GENERATION ..... | 326        |
| 14.5      | DEBUG MODE.....  | 327        |
| 14.6      | USER INTERFACE .....                                       | 327        |
| 14.6.1    | WWDG Configuration Flow .....                              | 327        |
| 14.7      | WWDG REGISTERS .....                                       | 327        |
| 14.7.1    | WWDG Register Overview .....                               | 327        |
| 14.7.2    | WWDG Control Register (WWDG_CTRL).....                     | 328        |
| 14.7.3    | WWDG Config Register (WWDG_CFG).....                       | 328        |
| 14.7.4    | WWDG Status Register (WWDG_STS).....                       | 329        |
| <b>15</b> | <b>ANALOG TO DIGITAL CONVERSION (ADC) .....</b>            | <b>330</b> |
| 15.1      | INTRODUCTION.....  | 330        |
| 15.2      | MAIN FEATURES.....   | 330        |
| 15.3      | FUNCTION DESCRIPTION.....                                  | 331        |
| 15.3.1    | ADC Clock .....  | 332        |
| 15.3.2    | ADC Switch Control .....                                   | 332        |

|           |  |            |
|-----------|--|------------|
| 15.3.3    | Channel Selection.....   | 333        |
| 15.3.4    | Internal Channel.....  | 333        |
| 15.3.5    | Single Conversion Mode .....   | 333        |
| 15.3.6    | Continuous Conversion Mode.....  | 334        |
| 15.3.7    | Timing Diagram .....   | 334        |
| 15.3.8    | Analog Watchdog .....  | 334        |
| 15.3.9    | Scan Mode .....  | 335        |
| 15.3.10   | Injection Channel Management.....  | 335        |
| 15.3.11   | Discontinuous Mode.....  | 336        |
| 15.4      | DATA ALIGNED.....  | 337        |
| 15.5      | PROGRAMMABLE CHANNEL SAMPLING TIME.....                                  | 337        |
| 15.6      | EXTERNALLY TRIGGERED CONVERSION .....                                    | 338        |
| 15.7      | DMA REQUESTS.....  | 339        |
| 15.8      | TEMPERATURE SENSOR.....  | 339        |
| 15.8.1    | Temperature Sensor Using Flow.....                                       | 340        |
| 15.9      | ADC INTERRUPT.....   | 340        |
| 15.10     | OPA CHANNEL CONTROL .....  | 340        |
| 15.11     | ADC REGISTERS.....   | 342        |
| 15.11.1   | ADC Register Overview .....  | 342        |
| 15.11.2   | ADC Status Register (ADC_STS).....                                       | 343        |
| 15.11.3   | ADC Control Register 1 (ADC_CTRL1) .....                                 | 344        |
| 15.11.4   | ADC Control Register 2 (ADC_CTRL2) .....                                 | 346        |
| 15.11.5   | ADC Sampling Time Register 1 (ADC_SAMPT1).....                           | 348        |
| 15.11.6   | ADC Sampling Time Register 2 (ADC_SAMPT2).....                           | 349        |
| 15.11.7   | ADC Sampling Time Register 3 (ADC_SAMPT3).....                           | 349        |
| 15.11.8   | ADC Injected Channel Data Offset Register X (ADC_JOFFSETx) (X=1..4)..... | 350        |
| 15.11.9   | ADC Watchdog High Threshold Register (ADC_WDGHIGH) .....                 | 350        |
| 15.11.10  | ADC Watchdog Low Threshold Register (ADC_WDGLow).....                    | 351        |
| 15.11.11  | ADC Regular Sequence Register 1 (ADC_RSEQ1) .....                        | 351        |
| 15.11.12  | ADC Regular Sequence Register 2 (ADC_RSEQ2) .....                        | 352        |
| 15.11.13  | ADC Regular Sequence Register 3 (ADC_RSEQ3) .....                        | 352        |
| 15.11.14  | ADC Injection Sequence Register (ADC_JSEQ).....                          | 353        |
| 15.11.15  | ADC Injection Data Register X (ADC_JDATx) (X= 1..4).....                 | 354        |
| 15.11.16  | ADC Regulars Data Register (ADC_DAT).....                                | 354        |
| 15.11.17  | ADC Control Register 3 (ADC_CTRL3) .....                                 | 355        |
| 15.11.18  | ADC Test Register (ADC_TEST) .....                                       | 356        |
| 15.11.19  | ADC OPA Control Register (ADC_OPACTRL) .....                             | 356        |
| <b>16</b> | <b>COMPARATOR (COMP).....</b>  | <b>358</b> |
| 16.1      | COMP SYSTEM CONNECTION BLOCK DIAGRAM .....                               | 358        |
| 16.2      | COMP FEATURES .....  | 358        |
| 16.3      | COMP CONFIGURATION PRECEDURE .....                                       | 359        |
| 16.4      | COMP OPERATING MODE .....  | 359        |

|           |  |            |
|-----------|--|------------|
| 16.4.1    | Independent Comparator.....  | 359        |
| 16.5      | COMPARATOR INTERCONNECTION .....   | 360        |
| 16.6      | INTERRUPT .....  | 360        |
| 16.7      | COMP REGISTER.....   | 361        |
| 16.7.1    | COMP Register Overview .....   | 361        |
| 16.7.2    | COMP Interrupt Enable Register (COMP_INTEN) .....                            | 361        |
| 16.7.3    | COMP Interrupt Register (COMP_INTSTS).....                                   | 362        |
| 16.7.4    | COMP Lock Register(COMP_LOCK).....   | 362        |
| 16.7.5    | COMP Control Register (COMP_CTRL).....                                       | 363        |
| 16.7.6    | COMP Filter Control Register (COMP_FILC).....                                | 364        |
| 16.7.7    | COMP Filter Frequency Division Register (COMP_FILP).....                     | 365        |
| 16.7.8    | COMP Reference Input Compare Voltage Register (COMP_INVREF).....             | 365        |
| <b>17</b> | <b>I<sup>2</sup>C INTERFACE .....</b>  | <b>367</b> |
| 17.1      | INTRODUCTION.....  | 367        |
| 17.2      | MAIN FEATURES .....  | 367        |
| 17.3      | FUNCTION DESCRIPTION.....  | 368        |
| 17.3.1    | SDA and SCL Line Control .....   | 368        |
| 17.3.2    | Software Communication Process .....   | 369        |
| 17.3.3    | Error Conditions Description.....  | 379        |
| 17.3.4    | DMA Application.....   | 380        |
| 17.3.5    | Packet Error Check(PEC) .....  | 381        |
| 17.3.6    | SMBus .....  | 382        |
| 17.4      | DEBUG MODE.....  | 384        |
| 17.5      | INTERRUPT REQUEST .....  | 384        |
| 17.6      | I <sup>2</sup> C REGISTERS.....  | 385        |
| 17.6.1    | I <sup>2</sup> C Register Overview .....                                     | 385        |
| 17.6.2    | I <sup>2</sup> C Control Register 1 (I2C_CTRL1).....                         | 386        |
| 17.6.3    | I <sup>2</sup> C Control Register 2 (I2C_CTRL2).....                         | 388        |
| 17.6.4    | I <sup>2</sup> C Own Address Register 1 (I2C_OADDR1) .....                   | 389        |
| 17.6.5    | I <sup>2</sup> C Own Address Register 2 (I2C_OADDR2) .....                   | 390        |
| 17.6.6    | I <sup>2</sup> C Data Register (I2C_DAT).....                                | 390        |
| 17.6.7    | I <sup>2</sup> C Status Register 1 (I2C_STS1).....                           | 391        |
| 17.6.8    | I <sup>2</sup> C Status Register 2 (I2C_STS2).....                           | 394        |
| 17.6.9    | I <sup>2</sup> C Clock Control Register (I2C_CLKCTRL) .....                  | 395        |
| 17.6.10   | I <sup>2</sup> C Rise Time Register (I2C_TMRISE) .....                       | 396        |
| <b>18</b> | <b>UNIVERSAL SYNCHRONOUS ASYNCHRONOUS RECEIVER TRANSMITTER (USART) .....</b> | <b>398</b> |
| 18.1      | INTRODUCTION.....  | 398        |
| 18.2      | MAIN FEATURES .....  | 398        |
| 18.3      | FUNCTIONAL BLOCK DIAGRAM .....   | 401        |
| 18.4      | FUNCTION DESCRIPTION.....  | 401        |
| 18.4.1    | USART Frame Format.....  | 402        |

|           |   |            |
|-----------|---|------------|
| 18.4.2    | Transmitter.....  | 403        |
| 18.4.3    | Receiver.....   | 406        |
| 18.4.4    | Generation of Fractional Baud Rate .....                                    | 410        |
| 18.4.5    | Receiver's Tolerance Clock Deviation.....                                   | 411        |
| 18.4.6    | Parity Control .....  | 412        |
| 18.4.7    | DMA Communication .....   | 413        |
| 18.4.8    | Hardware Flow Control .....   | 415        |
| 18.4.9    | Multiprocessor Communication .....  | 417        |
| 18.4.10   | Synchronous Mode .....  | 419        |
| 18.4.11   | Single-wire Half-duplex Mode .....  | 422        |
| 18.4.12   | Serial IrDA Infrared Encoding/Decoding Mode .....                           | 423        |
| 18.4.13   | LIN Mode .....  | 425        |
| 18.4.14   | Smartcard Mode (ISO7816).....   | 427        |
| 18.5      | INTERRUPT REQUEST .....   | 429        |
| 18.6      | MODE SUPPORT .....  | 430        |
| 18.7      | USART REGISTER .....  | 430        |
| 18.7.1    | USART Register Overview.....  | 430        |
| 18.7.2    | USART Status Register (USART_STS) .....                                     | 431        |
| 18.7.3    | USART Data Register (USART_DAT).....  | 433        |
| 18.7.4    | USART Baud Rate Register (USART_BRCF) .....                                 | 434        |
| 18.7.5    | USART Control Register 1 Register (USART_CTRL1) .....                       | 434        |
| 18.7.6    | USART Control Register 2 Register (USART_CTRL2) .....                       | 436        |
| 18.7.7    | USART Control Register 3 Register (USART_CTRL3) .....                       | 437        |
| 18.7.8    | USART Guard Time and Prescaler Register (USART_GTP).....                    | 439        |
| <b>19</b> | <b>LOW POWER UNIVERSAL ASYNCHRONOUS RECEIVER TRANSMITTER (LPUART) .....</b> | <b>441</b> |
| 19.1      | INTRODUCTION.....   | 441        |
| 19.2      | MAIN FEATURES .....   | 441        |
| 19.3      | FUNCTIONAL BLOCK DIAGRAM .....  | 442        |
| 19.4      | FUNCTION DESCRIPTION.....   | 442        |
| 19.4.1    | LPUART Frame Format .....   | 443        |
| 19.4.2    | Transmitter.....  | 443        |
| 19.4.3    | Receiver.....   | 445        |
| 19.4.4    | Fractional Baud Rate Generation.....  | 447        |
| 19.4.5    | Parity Control .....  | 448        |
| 19.4.6    | DMA Application.....  | 449        |
| 19.4.7    | Hardware Flow Control .....   | 451        |
| 19.4.8    | Low Power Wake Up .....   | 453        |
| 19.5      | INTERRUPT REQUEST .....   | 453        |
| 19.6      | LPUART REGISTERS.....   | 453        |
| 19.6.1    | LPUART Register Overview .....  | 453        |
| 19.6.2    | LPUART Status Register (LPUART_STS) .....                                   | 454        |
| 19.6.3    | LPUART Interrupt Enable Register (LPUART_INTEN) .....                       | 455        |

|  |  |            |
|--|--|------------|
| 19.6.4   | LPUART Control Register (LPUART_CTRL).....   | 456        |
| 19.6.5   | LPUART Baud Rate Configuration Register 1 (LPUART_BRCFG1).....                     | 457        |
| 19.6.6   | LPUART Data Register (LPUART_DAT).....   | 457        |
| 19.6.7   | LPUART Baud Rate Configuration Register 2 (LPUART_BRCFG2).....                     | 458        |
| 19.6.8   | LPUART Wake Up Data Register (LPUART_WUDAT) .....                                  | 458        |
| <b>20 SERIAL PERIPHERAL INTERFACE/INTER-IC SOUND (SPI/ I<sup>2</sup>S) .....</b> |  | <b>460</b> |
| 20.1   | SPI AND I <sup>2</sup> S INTRODUCTIONS .....                                       | 460        |
| 20.2   | SPI AND I <sup>2</sup> S MAIN FEATURES .....                                       | 460        |
| 20.2.1   | SPI Features .....   | 460        |
| 20.2.2   | I <sup>2</sup> S Features .....  | 461        |
| 20.3   | SPI FUNCTION DESCRIPTION .....   | 462        |
| 20.3.1   | General Description .....  | 462        |
| 20.3.2   | SPI Operating Mode .....   | 465        |
| 20.3.3   | Status Flag .....  | 471        |
| 20.3.4   | Turn off SPI .....   | 472        |
| 20.3.5   | SPI Communication Using DMA .....  | 473        |
| 20.3.6   | CRC Calculation .....  | 474        |
| 20.3.7   | Error Flag.....  | 475        |
| 20.3.8   | SPI Interrupt .....  | 476        |
| 20.4   | I <sup>2</sup> S FUNCTION DESCRIPTION.....   | 477        |
| 20.4.1   | Supported Audio Protocols .....  | 478        |
| 20.4.2   | Clock Generator.....   | 484        |
| 20.4.3   | I <sup>2</sup> S Transmit and Receive Sequence .....                               | 486        |
| 20.4.4   | Status Flag .....  | 488        |
| 20.4.5   | Error Flag.....  | 489        |
| 20.4.6   | I <sup>2</sup> S Interrupt .....   | 489        |
| 20.4.7   | DMA Function.....  | 489        |
| 20.5   | SPI AND I <sup>2</sup> S REGISTER DESCRIPTION .....                                | 490        |
| 20.5.1   | SPI Register Overview.....   | 490        |
| 20.5.2   | SPI Control Register 1 (SPI_CTRL1) (Not Used in I <sup>2</sup> S Mode).....        | 490        |
| 20.5.3   | SPI Control Register 2 (SPI_CTRL2).....  | 493        |
| 20.5.4   | SPI Status Register (SPI_STS) .....  | 493        |
| 20.5.5   | SPI Data Register (SPI_DAT).....   | 495        |
| 20.5.6   | SPI CRC Polynomial Register (SPI_CRCPOLY) (Not Used in I <sup>2</sup> S Mode)..... | 495        |
| 20.5.7   | SPI RX CRC Register (SPI_CRCRDAT) (Not Used in I <sup>2</sup> S Mode).....         | 496        |
| 20.5.8   | SPI TX CRC Register (SPI_CRCTDAT) .....  | 496        |
| 20.5.9   | SPI I <sup>2</sup> S Configuration Register (SPI_I2SCFG) .....                     | 496        |
| 20.5.10  | SPI I <sup>2</sup> S Prescaler Register (SPI_I2SPREDIV).....                       | 498        |
| <b>21 REAL-TIME CLOCK (RTC) .....</b>  |  | <b>499</b> |
| 21.1   | DESCRIPTION .....  | 499        |
| 21.2   | MAIN FEATURES.....   | 499        |

|  |            |
|--|------------|
| 21.3 RTC FUNCTION DESCRIPTION.....                           | 500        |
| 21.3.1 RTC Block Diagram .....                               | 500        |
| 21.3.2 GPIOs of RTC.....                                     | 501        |
| 21.3.3 RTC Register Write Protection .....                   | 501        |
| 21.3.4 RTC Clock and Prescaler.....                          | 501        |
| 21.3.5 RTC Calendar .....                                    | 502        |
| 21.3.6 Calendar Initialization and Configuration.....        | 502        |
| 21.3.7 Calendar Reading.....                                 | 503        |
| 21.3.8 Calibration Clock Output.....                         | 503        |
| 21.3.9 Programmable Alarms .....                             | 504        |
| 21.3.10 Alarm Configuration.....                             | 504        |
| 21.3.11 Alarm Output.....                                    | 504        |
| 21.3.12 Periodic Automatic Wakeup.....                       | 504        |
| 21.3.13 Wakeup Timer Configuration .....                     | 505        |
| 21.3.14 Timestamp Function .....                             | 505        |
| 21.3.15 Tamper Detection.....                                | 506        |
| 21.3.16 Daylight Saving Time Function Configuration.....     | 506        |
| 21.3.17 RTC Sub-second Register Shift .....                  | 506        |
| 21.3.18 RTC Digital Clock Precision Calibration.....         | 507        |
| 21.3.19 RTC Low Power Mode .....                             | 508        |
| 21.4 RTC REGISTERS .....                                     | 508        |
| 21.4.1 RTC Register Overview .....                           | 508        |
| 21.4.2 RTC Calendar Time Register (RTC_TSH) .....            | 509        |
| 21.4.3 RTC Calendar Date Register (RTC_DATE) .....           | 510        |
| 21.4.4 RTC Control Register (RTC_CTRL) .....                 | 511        |
| 21.4.5 RTC Initial Status Register (RTC_INITSTS) .....       | 513        |
| 21.4.6 RTC Prescaler Register (RTC_PRE) .....                | 515        |
| 21.4.7 RTC Wakeup Timer Register (RTC_WKUPT).....            | 516        |
| 21.4.8 RTC Alarm A Register (RTC_ALARMa).....                | 516        |
| 21.4.9 RTC Alarm B Register (RTC_ALARMb).....                | 517        |
| 21.4.10 RTC Write Protection Register (RTC_WRP).....         | 518        |
| 21.4.11 RTC Sub-second Register (RTC_SUBS).....              | 519        |
| 21.4.12 RTC Shift Control Register (RTC_SCTRL) .....         | 519        |
| 21.4.13 RTC Timestamp Time Register (RTC_TST) .....          | 520        |
| 21.4.14 RTC Timestamp Date Register (RTC_TSD).....           | 520        |
| 21.4.15 RTC Timestamp Sub-second Register (RTC_TSSS) .....   | 521        |
| 21.4.16 Rtc Calibration Register (RTC_CALIB).....            | 521        |
| 21.4.17 RTC Tamper Configuration Register (RTC_TMPCFG) ..... | 522        |
| 21.4.18 RTC Alarm A Sub-second Register (RTC_ALRMAS).....    | 524        |
| 21.4.19 RTC Alarm B Sub-second Register (RTC_ALRMBSS).....   | 525        |
| <b>22 OPERATIONAL AMPLIFIER (OPAMP) .....</b>                | <b>527</b> |
| 22.1 OPAMP FEATURES .....                                    | 527        |

|           |  |            |
|-----------|--|------------|
| 22.1.1    | OPAMP Function Description .....                 | 527        |
| 22.2      | OPAMP OPERATING MODE .....                       | 528        |
| 22.2.1    | External Gain Mode.....                          | 528        |
| 22.2.2    | Follower Mode.....                               | 529        |
| 22.2.3    | Programmable Gain Amplification (PGA) Mode ..... | 530        |
| 22.2.4    | Independent Write Protection .....               | 531        |
| 22.2.5    | TIMER Controls The Switching Mode.....           | 531        |
| 22.3      | OPAMP REGISTERS .....                            | 531        |
| 22.3.1    | OPAMP Register Overview .....                    | 531        |
| 22.3.2    | Opamp Control Status Register (OPAMP_CS).....    | 532        |
| 22.3.3    | Opamp Lock Register (OPAMP_LOCK) .....           | 533        |
| <b>23</b> | <b>BEEPER.....</b>                               | <b>534</b> |
| 23.1      | INTRODUCTION.....                                | 534        |
| 23.2      | FUNCTION DESCRIPTION.....                        | 534        |
| 23.3      | BEEPER REGISTERS .....                           | 534        |
| 23.3.1    | Beeper Register Overview .....                   | 534        |
| 23.3.2    | Beeper Control Register (BEEPER_CTRL).....       | 534        |
| <b>24</b> | <b>ARITHMETIC UNITS (HDIV AND SQRT).....</b>     | <b>537</b> |
| 24.1      | INTRODUCTIONS OF HDIV AND SQRT .....             | 537        |
| 24.2      | HDIV AND SQRT FUNCTION DESCRIPTION.....          | 537        |
| 24.3      | HDIV REGISTERS .....                             | 537        |
| 24.3.1    | HDIV Register Overview .....                     | 537        |
| 24.3.2    | HDIV Control Status Register (HDIV_CTRLSTS)..... | 538        |
| 24.3.3    | HDIV Dividend Register (HDIV_DIVIDEND) .....     | 538        |
| 24.3.4    | HDIV Divisor Register (HDIV_DIVISOR) .....       | 539        |
| 24.3.5    | HDIV Quotient Register (HDIV_QUOTIENT).....      | 539        |
| 24.3.6    | HDIV Remainder Register (HDIV_REMAINDER) .....   | 539        |
| 24.3.7    | HDIV Divide by Zero Register (HDIV_DIVBY0).....  | 540        |
| 24.4      | SQRT REGISTERS.....                              | 540        |
| 24.4.1    | SQRT Register Overview .....                     | 540        |
| 24.4.2    | SQRT Control Status Register (SQRT_CTRLSTS)..... | 540        |
| 24.4.3    | SQRT Radicand Register (SQRT_RADICAND).....      | 541        |
| 24.4.4    | SQRT Square Root Register (SQRT_ROOT).....       | 542        |
| <b>25</b> | <b>DEBUG SUPPORT (DBG) .....</b>                 | <b>543</b> |
| 25.1      | OVERVIEW.....                                    | 543        |
| 25.2      | SWD FUNCTION.....                                | 544        |
| 25.2.1    | Pin Assignment .....                             | 544        |
| <b>26</b> | <b>UNIQUE DEVICE SERIAL NUMBER (UID) .....</b>   | <b>545</b> |
| 26.1      | INTRODUCTION.....                                | 545        |

26.2 UID REGISTER..... 545

26.3 UCID REGISTER..... 545

26.4 DBGMCU\_ID REGISTER ..... 545

**27 VERSION HISTORY .....547**

**28 DISCLAIMER .....548**



## List of Table

|   |     |
|---|-----|
| Table 2-1 List of Peripheral Register Addresses.....                          | 31  |
| Table 2-2 List of Boot Mode .....   | 33  |
| Table 2-3 Flash Bus Address List.....   | 34  |
| Table 2-4 Option Byte List.....   | 38  |
| Table 2-5 Read Protection Configuration List.....                             | 39  |
| Table 2-6 Flash Read-write-erase <sup>(1)</sup> Permission Control Table..... | 41  |
| Table 2-7 FLASH Register Overview .....                                       | 46  |
| Table 3-1 Power Modes.....  | 56  |
| Table 3-2 Peripheral Running Status .....                                     | 57  |
| Table 3-3 PWR Register Overview .....   | 61  |
| Table 4-1 RCC Register Overview.....  | 79  |
| Table 5-1 I/O Port Configuration Table.....                                   | 104 |
| Table 5-2 I/O List of Functional Features of The Pin.....                     | 105 |
| Table 5-3 I/O List of Functional Features of The Pin.....                     | 110 |
| Table 5-4 TIM1 Alternate Function I/O Remapping .....                         | 110 |
| Table 5-5 TIM8 Alternate Function I/O Remapping .....                         | 111 |
| Table 5-6 TIM3 Alternate Function I/O Remapping .....                         | 111 |
| Table 5-7 LPTIM Alternate Function I/O Remapping.....                         | 112 |
| Table 5-8 USART1 Alternate Function I/O Remapping.....                        | 112 |
| Table 5-9 USART2 Alternate Function I/O Remapping.....                        | 113 |
| Table 5-10 LPUART Alternate Function I/O Remapping .....                      | 113 |
| Table 5-11 I <sup>2</sup> C1 Alternate Function I/O Remapping .....           | 114 |
| Table 5-12 I <sup>2</sup> C2 Alternate Function I/O Remapping .....           | 114 |
| Table 5-13 SPI1/I <sup>2</sup> S Alternate Function I/O Remapping.....        | 115 |
| Table 5-14 SPI2 Alternate Function I/O Remapping.....                         | 116 |
| Table 5-15 COMP Alternate Function I/O Remapping .....                        | 116 |
| Table 5-16 BEEPER Alternate Function I/O Remapping.....                       | 116 |
| Table 5-17 EVENTOUT Alternate Function I/O Remapping.....                     | 116 |
| Table 5-18 RTC Alternate Function I/O Remapping .....                         | 117 |

|  |     |
|--|-----|
| Table 5-19 RCC Alternate Function I/O Remapping.....   | 117 |
| Table 5-20 OSC_IN/OSC_OUT Alternate Function I/O Remapping.....                                | 117 |
| Table 5-21 OSC32 Alternate Function Remapping .....  | 118 |
| Table 5-22 OSC Alternate Function Remapping .....  | 118 |
| Table 5-23 ADC External Trigger Injection Conversion Alternate Function Remapping .....        | 118 |
| Table 5-24 ADC External Trigger Regular Conversion Alternate Function Remapping.....           | 119 |
| Table 5-25 ADC.....  | 119 |
| Table 5-26 PVD.....  | 119 |
| Table 5-27 TIM1/TIM8 .....   | 119 |
| Table 5-28 TIM3 and LPTIM .....  | 119 |
| Table 5-29 USART .....   | 119 |
| Table 5-30 LPUART.....   | 120 |
| Table 5-31 I <sup>2</sup> C .....  | 120 |
| Table 5-32 SPI.....  | 120 |
| Table 5-33 COMP .....  | 120 |
| Table 5-34 BEEPER.....   | 121 |
| Table 5-35 Other.....  | 121 |
| Table 5-36 GPIO Register Overview.....   | 122 |
| Table 5-37 AFIO Register Overview .....  | 131 |
| Table 6-1 Vector Table.....  | 135 |
| Table 6-2 EXTI Register Overview .....   | 143 |
| Table 7-1 Programmable Data Width and Endian Operation (When PINC = MINC = 1) .....            | 150 |
| Table 7-2 Flow Control Table.....  | 153 |
| Table 7-3 DMA Interrupt Request .....  | 154 |
| Table 7-4 DMA Request Mapping.....   | 155 |
| Table 7-5 DMA Register Overview .....  | 155 |
| Table 8-1 CRC Register Overview .....  | 164 |
| Table 9-1 Counting Direction Versus Encoder Signals.....                                       | 202 |
| Table 9-2 Register Overview .....  | 206 |
| Table 9-3 TIMx Internal Trigger Connection .....   | 213 |
| Table 9-4 Output Control Bits of Complementary OCx and OCxN Channels with Break Function ..... | 225 |

|   |     |
|---|-----|
| Table 10-1 Counting Direction Versus Encoder Signals.....                     | 262 |
| Table 10-2 Register Overview .....  | 264 |
| Table 10-3 TIMx Internal Trigger Connection .....                             | 271 |
| Table 10-4 Output Control Bits of Standard OCx Channel .....                  | 281 |
| Table 11-1 Register Overview .....  | 292 |
| Table 12-1 Pre-scaler Division Ratios .....                                   | 299 |
| Table 12-2 6 Trigger Inputs Corresponding to LPTIM_CFG.TRGSEL[2:0] Bits ..... | 300 |
| Table 13-1 IWDG Counting Maximum and Minimum Reset Time .....                 | 321 |
| Table 13-2 IWDG Register Overview .....                                       | 322 |
| Table 14-1 Maximum and Minimum Counting Time of WWDG .....                    | 327 |
| Table 14-2 WWDG Register Overview.....  | 327 |
| Table 15-1 ADC Pins.....  | 331 |
| Table 15-2 Analog Watchdog Channel Selection .....                            | 335 |
| Table 15-3 Right-align Data .....   | 337 |
| Table 15-4 Left-align Data.....   | 337 |
| Table 15-5 ADC is Used for External Triggering of Regular Channels .....      | 338 |
| Table 15-6 ADC Is Used for External Triggering of Injection Channels.....     | 338 |
| Table 15-7 ADC Interrupt.....   | 340 |
| Table 15-8 OPA Channel Selection .....  | 341 |
| Table 15-9 ADC Register Overview.....   | 342 |
| Table 16-1 COMP Register Overview.....  | 361 |
| Table 17-1 Comparison Between SMBus and I <sup>2</sup> C.....                 | 382 |
| Table 17-2 I <sup>2</sup> C Interrupt Request.....                            | 384 |
| Table 17-3 I <sup>2</sup> C Register Overview.....                            | 385 |
| Table 18-1 Mode Configuration for USARTx and LPUART .....                     | 399 |
| Table 18-2 Stop Bit Configuration .....                                       | 403 |
| Table 18-3 Data Sampling for Noise Detection.....                             | 409 |
| Table 18-4 Error Calculation When Setting Baud Rate.....                      | 411 |
| Table 18-5 When DIV_Decimal = 0. Tolerance of USART Receiver .....            | 411 |
| Table 18-6 When DIV_Decimal != 0. Tolerance of USART Receiver.....            | 412 |
| Table 18-7 Frame Format .....   | 412 |

|  |     |
|--|-----|
| Table 18-8 USART Interrupt Request .....   | 429 |
| Table 18-9 USART Mode Setting <sup>(1)</sup> .....                               | 430 |
| Table 18-10 USART Register Overview .....  | 430 |
| Table 19-1 Data Sampling for Noise Detection.....                                | 447 |
| Table 19-2 Parity Frame Format.....  | 449 |
| Table 19-3 LPUART Interrupt Requests .....                                       | 453 |
| Table 19-4 LPUART Register Overview.....   | 453 |
| Table 20-1 SPI Interrupt Request .....   | 476 |
| Table 20-2 Use The Standard 8MHz HSE Clock to Get Accurate Audio Frequency. .... | 486 |
| Table 20-3 I <sup>2</sup> S interrupt request.....                               | 489 |
| Table 20-4 SPI Register Overview .....   | 490 |
| Table 21-1 RTC Feature Support.....  | 499 |
| Table 21-2 RTC Register Overview .....   | 508 |
| Table 22-1 OPAMP Register Overview.....  | 531 |
| Table 23-1 Beeper Register Overview.....   | 534 |
| Table 24-1 HDIV Register Overview .....  | 537 |
| Table 24-2 SQRT Register Overview .....  | 540 |
| Table 26-1 DBGMCU_ID Bit Description.....  | 545 |

## List of Figure

|  |     |
|--|-----|
| Figure 2-1 Bus Architecture .....  | 29  |
| Figure 2-2 Bus Address Map .....   | 30  |
| Figure 3-1 Power Supply Block Diagram .....  | 54  |
| Figure 3-2 Power on Reset/Power down Reset Waveform.....   | 55  |
| Figure 3-3 PVD Threshold Diagram .....   | 56  |
| Figure 4-1 System Reset Generation .....   | 71  |
| Figure 4-2 Clock Tree.....   | 74  |
| Figure 4-3 HSE Clock Source .....  | 75  |
| Figure 4-4 PLL Clock Configuration .....   | 76  |
| Figure 5-1 Basic Structure of I/O Ports .....  | 104 |
| Figure 5-2 Input Floating/Pull-up/Pull-down Configuration Mode.....  | 106 |
| Figure 5-3 Output Mode.....  | 107 |
| Figure 5-4 Alternate Function Mode .....   | 108 |
| Figure 5-5 Analog Function Mode with High Impedance .....  | 108 |
| Figure 6-1 External Interrupt/Event Controller Block Diagram .....   | 139 |
| Figure 6-2 External Interrupt Generic I/O Mapping.....   | 141 |
| Figure 7-1 DMA Block Diagram.....  | 149 |
| Figure 8-1 CRC Calculation Unit Block Diagram.....   | 163 |
| Figure 9-1 Block Diagram of TIM1 and TIM8 .....  | 169 |
| Figure 9-2 Counter Timing Diagram with Prescaler Division Change from 1 to 4 .....                           | 170 |
| Figure 9-3 Timing Diagram of Up-counting. The Internal Clock Divider Factor = 2/N .....                      | 171 |
| Figure 9-4 Timing Diagram of The Up-counting, Update Event When ARPEN = 0/1 .....                            | 172 |
| Figure 9-5 Timing Diagram of The Down-counting, Internal Clock Divided Factor = 2/N.....                     | 173 |
| Figure 9-6 Timing Diagram of The Center-aligned, Internal Clock Divided Factor =2/N .....                    | 174 |
| Figure 9-7 A Center-aligned Sequence Diagram That Includes Counter Overflows and Underflows (ARPEN = 1)..... | 175 |
| Figure 9-8 Repeat Count Sequence Diagram in Down-counting Mode .....   | 176 |
| Figure 9-9 Repeat Count Sequence Diagram in Up-counting Mode .....   | 177 |
| Figure 9-10 Repeat Count Sequence Diagram in Center-aligned Mode.....  | 177 |
| Figure 9-11 Control Circuit in Normal Mode, Internal Clock Divided By 1.....                                 | 178 |

Figure 9-12 TI2 External Clock Connection Example ..... 179

Figure 9-13 Control Circuit in External Clock Mode 1 ..... 180

Figure 9-14 External Trigger Input Block Diagram ..... 180

Figure 9-15 Control Circuit in External Clock Mode 2 ..... 181

Figure 9-16 Capture/Compare Channel (Example: Channel 1 Input Stage)..... 182

Figure 9-17 Capture/Compare Channel 1 Main Circuit ..... 183

Figure 9-18 Output Part of Channelx (x= 1,2,3, Take Channel 1 As Example) ..... 183

Figure 9-19 Output Part of Channelx (x= 4) ..... 184

Figure 9-20 PWM Input Mode Timing..... 186

Figure 9-21 Output Compare Mode, Toggle on OC1 ..... 188

Figure 9-22 Center-aligned PWM Waveform (AR=8) ..... 189

Figure 9-23 Edge-aligned PWM Waveform (APR=8) ..... 190

Figure 9-24 Example of One-pulse Mode ..... 191

Figure 9-25 Clearing The OCxREF of TIMx ..... 192

Figure 9-26 Complementary Output with Dead-time Insertion..... 194

Figure 9-27 Output Behavior in Response to A Break ..... 196

Figure 9-28 Control Circuit in Reset Mode ..... 197

Figure 9-29 Control Circuit in Trigger Mode ..... 198

Figure 9-30 Control Circuit in Gated Mode ..... 199

Figure 9-31 Control Circuit in Trigger Mode + External Clock Mode2..... 200

Figure 9-32 6-step PWM Generation, COM Example (OSSR=1) ..... 201

Figure 9-33 Example of Counter Operation in Encoder Interface Mode ..... 202

Figure 9-34 Encoder Interface Mode Example with IC1FP1 Polarity Inverted ..... 203

Figure 9-35 Example of Hall Sensor Interface ..... 205

Figure 10-1 Block Diagram of TIMx (x=3) ..... 236

Figure 10-2 Counter Timing Diagram with Prescaler Division Change from 1 to 4 ..... 237

Figure 10-3 Timing Diagram of Up-counting. The Internal Clock Divider Factor = 2/N ..... 238

Figure 10-4 Timing Diagram of The Up-counting, Update Event When ARPEN=0/1 ..... 239

Figure 10-5 Timing Diagram of The Down-counting, Internal Clock Divided Factor = 2/N..... 240

Figure 10-6 Timing Diagram of The Center-aligned, Internal Clock Divided Factor =2/N ..... 241

Figure 10-7 A Center-aligned Sequence Diagram That Includes Counter Overflows and Underflows (ARPEN = 1)

..... 242

Figure 10-8 Control Circuit in Normal Mode, Internal Clock Divided by 1 ..... 243

Figure 10-9 TI2 External Clock Connection Example ..... 244

Figure 10-10 Control Circuit in External Clock Mode 1 ..... 245

Figure 10-11 External Trigger Input Block Diagram ..... 245

Figure 10-12 Control Circuit in External Clock Mode 2 ..... 246

Figure 10-13 Capture/Compare Channel (Example: Channel 1 Input Stage)..... 247

Figure 10-14 Capture/Compare Channel 1 Main Circuit ..... 248

Figure 10-15 Output Part of Channelx (x = 1,2,3,4, Using Channel 4 as An Example ) ..... 249

Figure 10-16 PWM Input Mode Timing..... 251

Figure 10-17 Output Compare Mode, Toggle on OC1 ..... 253

Figure 10-18 Center-aligned PWM Waveform (AR=8) ..... 254

Figure 10-19 Edge-aligned PWM Waveform (APR=8) ..... 255

Figure 10-20 Example of One-pulse Mode ..... 256

Figure 10-21 Control Circuit in Reset Mode ..... 257

Figure 10-22 Block Diagram of Timer Interconnection ..... 258

Figure 10-23 TIM3 Gated by OC1REF of TIM1 ..... 259

Figure 10-24 TIM3 Gated by Enable Signal of TIM1 ..... 260

Figure 10-25 Trigger TIM3 with An Update of TIM1 ..... 261

Figure 10-26 Triggers Timers 1 and 3 Using The TI1 Input of TIM1 ..... 262

Figure 10-27 Example of Counter Operation in Encoder Interface Mode ..... 263

Figure 11-1 Block Diagram of TIMx (x = 6) ..... 287

Figure 11-2 Counter Timing Diagram with Prescaler Division Change from 1 to 4 ..... 288

Figure 11-3 Timing Diagram of Up-counting. The Internal Clock Divider Factor = 2/N ..... 289

Figure 11-4 Timing Diagram of The Up-counting, Update Event When ARPEN= 0/1 ..... 290

Figure 11-5 Control Circuit in Normal Mode, Internal Clock Divided by 1 ..... 291

Figure 12-1 LPTIM Diagram ..... 298

Figure 12-2 Glitch Filter Timing Diagram ..... 299

Figure 12-3 LPTIM Output Waveform, Continuous Counting Mode Configuration ..... 301

Figure 12-4 PTIM Output Waveform, Single Counting Mode Configuration..... 302

Figure 12-5 LPTIM Output Waveform, Single Counting Mode Configuration and Set-once Mode Activated ..... 303

Figure 12-6 Waveform Generation ..... 304

Figure 12-7 Encoder Mode Counting Sequence ..... 307

Figure 12-8 Input Waveforms of Input1 and Input2 When The Decoder Module Is Operating normally ..... 308

Figure 12-9 Input1 and Input2 Input Waveforms When Decoder Module Is Not Operating ..... 308

Figure 13-1 Functional Block Diagram of The Independent Watchdog Module ..... 320

Figure 14-1 Watchdog Block Diagram ..... 325

Figure 14-2 Refresh Window and Interrupt Timing of WWDG ..... 326

Figure 15-1 Block Diagram of A Single ADC ..... 331

Figure 15-2 ADC Clock ..... 332

Figure 15-3 Timing Diagram ..... 334

Figure 15-4 Injection Conversion Delay ..... 336

Figure 15-5 Temperature Sensor and VREFINT Diagram of The Channel ..... 339

Figure 15-6 TIM1 CC4 Triggers OPA Channel Switching ADC Injection Sampling ..... 341

Figure 16-1 Comparator System Connection Diagram ..... 358

Figure 17-1 I<sup>2</sup>C Functional Block Diagram ..... 370

Figure 17-2 I<sup>2</sup>C Bus Protocol ..... 370

Figure 17-3 Slave Transmitter Transfer Sequence Diagram ..... 373

Figure 17-4 Slave Receiver Transfer Sequence Diagram ..... 374

Figure 17-5 Master Transmitter Transfer Sequence Diagram ..... 376

Figure 17-6 Master Receiver Transfer Sequence Diagram ..... 378

Figure 18-1 USART Block Diagram ..... 401

Figure 18-2 Word Length = 8 Setting ..... 402

Figure 18-3 Word Length = 9 Setting ..... 403

Figure 18-4 Configuration Stop Bit ..... 404

Figure 18-5 TXC/TXDE Changes During Transmission ..... 406

Figure 18-6 Start Bit Detection ..... 407

Figure 18-7 Transmission Using DMA ..... 414

Figure 18-8 Reception Using DMA ..... 415

Figure 18-9 Hardware Flow Control Between Two USART ..... 415

Figure 18-10 RTS Flow Control ..... 416

Figure 18-11 CTS Flow Controls ..... 417



Figure 18-12 Mute Mode Using Idle Line Detection ..... 418

Figure 18-13 Mute Mode Detected Using Address Mark..... 419

Figure 18-14 USART Synchronous Transmission Example ..... 420

Figure 18-15 USART Data Clock Timing Example (WL=0)..... 421

Figure 18-16 USART Data Clock Timing Example (WL=1)..... 422

Figure 18-17 RX Data Sampling/Holding Time..... 422

Figure 18-18 IrDA Block Diagram..... 424

Figure 18-19 IrDA Data Modulation (3/16)-Normal Mode..... 424

Figure 18-20 Break Detection in LIN Mode (11-bit Break Length, The LINBDL Bit Is Set) ..... 426

Figure 18-21 Break Detection and Framing Error Detection in LIN Mode ..... 427

Figure 18-22 ISO7816-3 Asynchronous Protocol ..... 428

Figure 18-23 Use 1.5 Stop Bits to Detect Parity Errors..... 429

Figure 19-1 LPUART Block Diagram..... 442

Figure 19-2 Frame Format..... 443

Figure 19-3 TXC Changes During Transmission ..... 445

Figure 19-4 Data Sampling for Noise Detection ..... 447

Figure 19-5 Sending Using DMA ..... 450

Figure 19-6 Receiving with DMA..... 451

Figure 19-7 Hardware Flow Control Between Two LPUART ..... 451

Figure 19-8 RTS Flow Control..... 452

Figure 19-9 CTS Flow Control..... 452

Figure 20-1 SPI Block Diagram ..... 462

Figure 20-2 Selective Management of Hardware/Software..... 463

Figure 20-3 Master and Slave Applications..... 464

Figure 20-4 Data Clock Timing Diagram..... 465

Figure 20-5 Changes of TE/RNE/BUSY During Continuous Transmission in Master Full Duplex Mode..... 466

Figure 20-6 Changes of TE/BUSY During The Host Transmits Continuously in One-way Transmit-only Mode... 467

Figure 20-7 Changes of RNE During Continuous Transmission Occurs in Receive-only Mode (BIDIRMODE = 0 and RONLY = 1)..... 467

Figure 20-8 Changes of TE/RNE/BUSY During The Slave Is Continuously Transmitting in Full Duplex Mode... 469

Figure 20-9 Changes of TE/BUSY During Continuous Transmission in Slave Unidirectional Transmit-only Mode

..... 469

Figure 20-10 Schematic Diagram of TE/BUSY Change When BIDIRMODE = 0 and RONLY = 0 Are Transmitted Discontinuously..... 471

Figure 20-11 Transmission Using DMA ..... 474

Figure 20-12 Reception Using DMA ..... 474

Figure 20-13 I<sup>2</sup>S Block Diagram ..... 477

Figure 20-14 I<sup>2</sup>S Philips Protocol Waveform (16/32-bit Full Precision, CLKPOL = 0) ..... 479

Figure 20-15 I<sup>2</sup>S Philips Protocol Standard Waveform (24-bit Frame, CLKPOL = 0) ..... 479

Figure 20-16 I<sup>2</sup>S Philips Protocol Standard Waveform (16-bit Extended to 32-bit Packet Frame, CLKPOL = 0) .. 480

Figure 20-17 The MSB Is Aligned with 16-bit or 32-bit Full Precision, CLKPOL = 0. .... 481

Figure 20-18 MSB Aligns 24-bit Data, CLKPOL = 0 ..... 481

Figure 20-19 MSB-aligned 16-bit Data Is Extended to 32-bit Packet Frame, CLKPOL = 0 ..... 482

Figure 20-20 LSB Alignment 16-bit or 32-bit Full Precision, CLKPOL = 0 ..... 482

Figure 20-21 LSB Aligns 24-bit Data, CLKPOL = 0 ..... 483

Figure 20-22 LSB Aligned 16-bit Data Is Extended to 32-Bit Packet Frame, CLKPOL = 0 ..... 483

Figure 20-23 PCM Standard Waveform (16 Bits) ..... 484

Figure 20-24 PCM Standard Waveform (16-bit Extended to 32-bit Packet Frame)..... 484

Figure 20-25 I<sup>2</sup>S Clock Generator Structure ..... 485

Figure 20-26 Audio Sampling Frequency Definition ..... 485

Figure 21-1 RTC Block Diagram ..... 500

Figure 22-1 Block Diagram of OPAMP Connection Diagram ..... 527

Figure 22-2 OPAMP External Gain Mode..... 529

Figure 22-3 OPAMP Follower Mode ..... 530

Figure 22-4 OPAMP Programmable Gain Mode..... 531

# 1 Abbreviations in The Text

## 1.1 List of Abbreviations for Registers

The following abbreviations are used in register descriptions:

|                               |   |
|-------------------------------|---|
| read/write(rw)                | Software can read and write this bit.   |
| read-only(r)                  | Software can only read this bit.  |
| write-only(w)                 | Software can only write this bit, and reading this bit will return the reset value.                                     |
| read/clear(rc_w1)             | Software can read this bit or clear it by writing '1', and writing '0' has no effect on this bit.                       |
| read/clear(rc_w0)             | Software can read this bit or clear it by writing '0', and writing '1' has no effect on this bit.                       |
| read/clear by read(rc_r)      | Software can read this bit. Reading this bit will automatically clear it to '0'. Writing '0' has no effect on this bit. |
| read/set(rs)                  | Software can read or set this bit. Writing '0' has no effect on this bit.   |
| read-only write trigger(rt_w) | Software can read this bit and write '0' or '1' to trigger an event, but it has no effect on this bit value.            |
| toggle(t)                     | Software can only flip this bit by writing '1', and writing '0' has no effect on this bit.                              |
| Reserved(Res.)                | Reserved bit, must be kept at reset value.  |

## 1.2 Available Peripherals

For all models of N32G031 microcontroller series, the existence and number of a peripheral, please refer to the data sheet of the corresponding model.

## 2 Memory and Bus Architecture

### 2.1 System Architecture

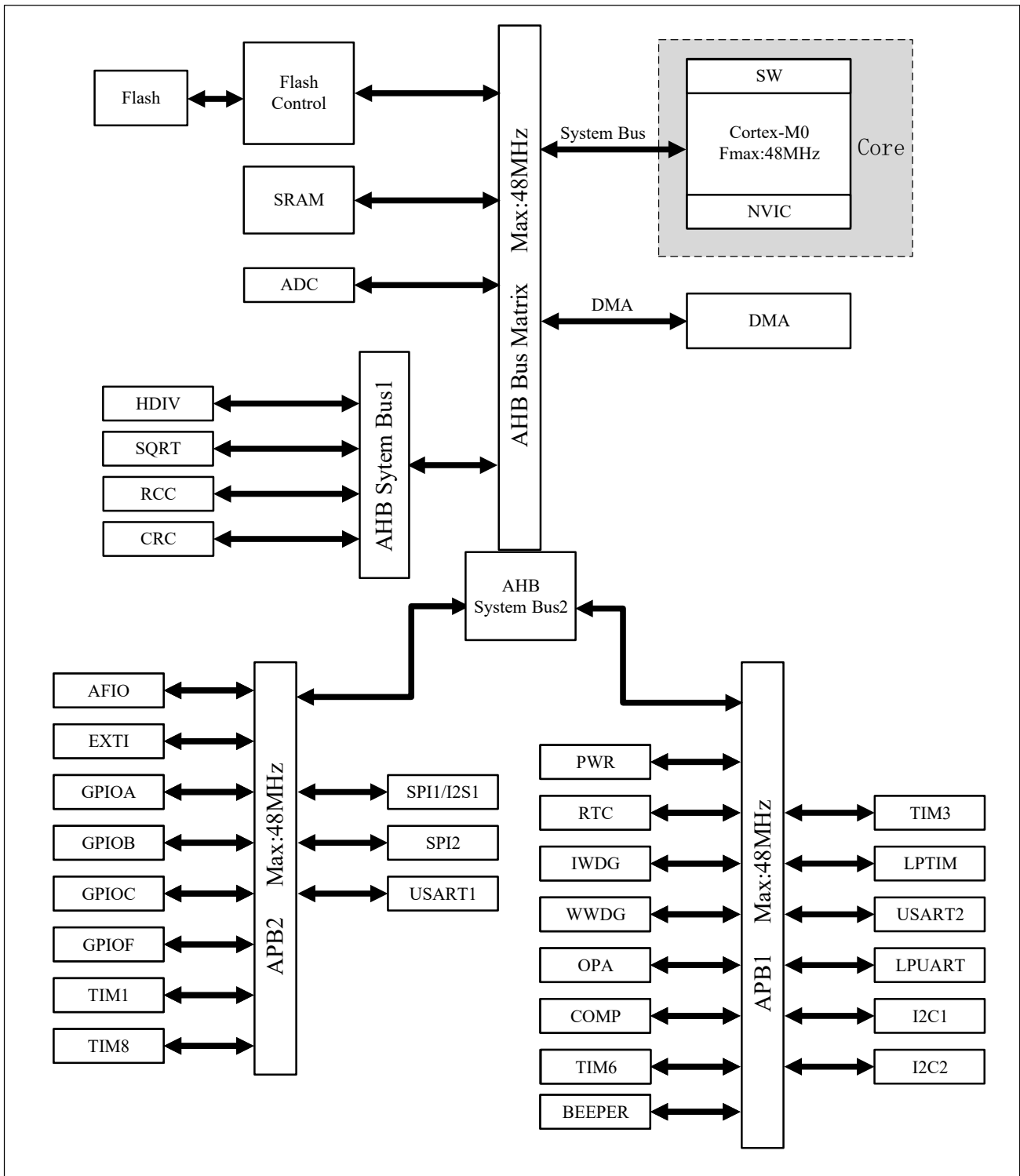
#### 2.1.1 Bus Architecture

The main system consists of the following parts:

- Two main drive units:
  - Cortex®-M0 core system bus
  - General purpose DMA
- Six passive units
  - Internal SRAM
  - Internal Flash memory
  - ADC
  - AHB to AHB bridge, it connects some AHB devices
  - AHB to APB bridges (AHB2APB1 and AHB2APB2), which connect all APB devices

These are connected to each other through a multi-level AHB bus architecture, as shown in **Figure 2-1**:

Figure 2-1 Bus Architecture



- CPU System bus: It connects the kernel Sbus of the Cortex®-M0 to bus matrix,, and is used for instruction pre-fetch, data loading (constant loading and debug access) and AHB/APB peripheral access.
- DMA bus: The DMA's AHB master interface is connected to the bus matrix, which coordinates access from the kernel

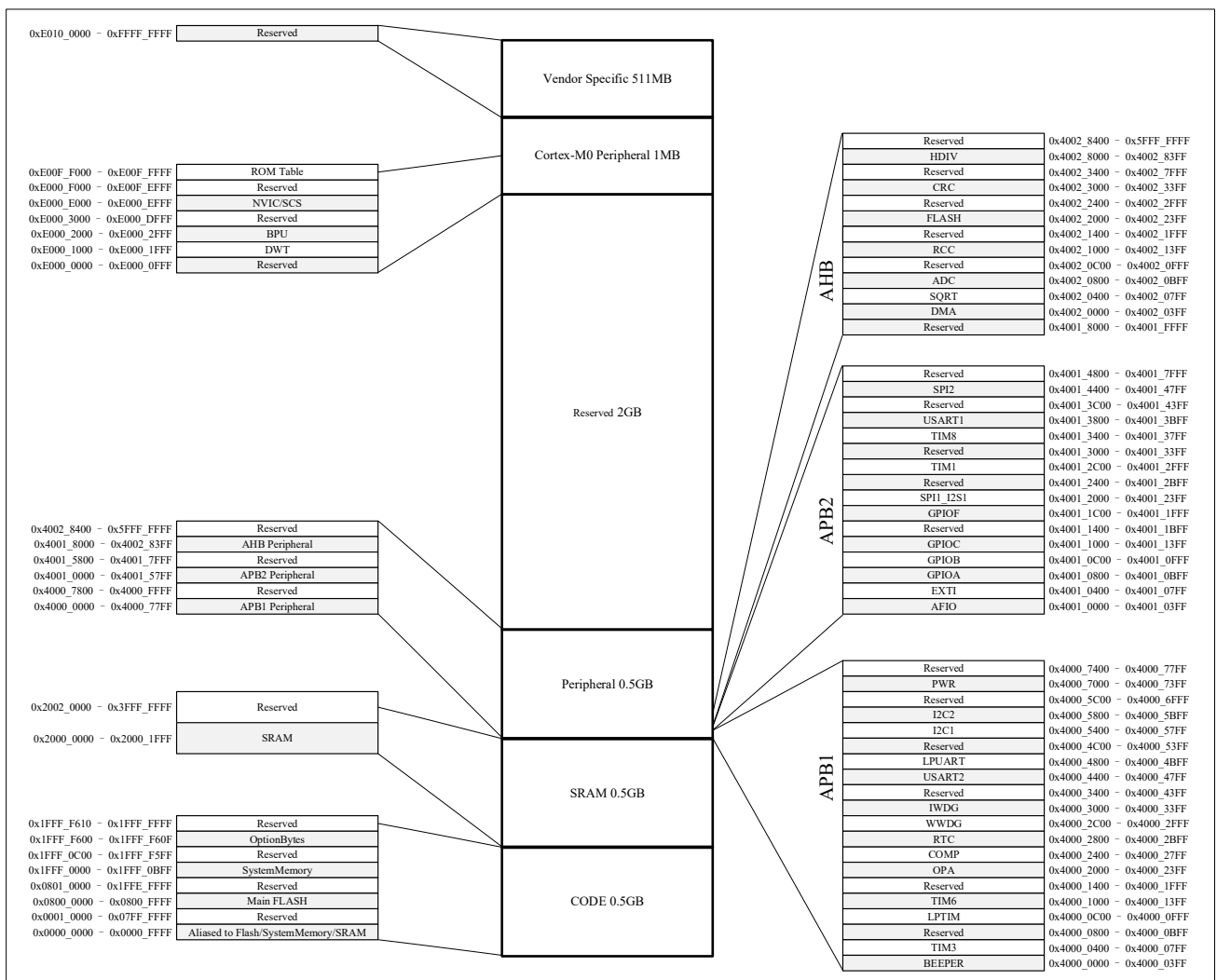
and DMA to SRAM, Flash and peripherals.

- The bus matrix coordinates access arbitration between the kernel system bus and the DMA master bus. The arbitration uses a Round Robin algorithm. The bus matrix consists of two driver components (CPU system bus, DMA bus) and six slave components (Flash memory interface, SRAM, ADC, and AHB system bus 1/2). Some AHB peripherals are connected to AHB system bus 1 through a bus matrix, and AHB system bus 2 is connected to two AHB2APB Bridges.
- The system consists of two AHB2APB Bridges, i.e. AHB2APB1 and AHB2APB2. APB1 contains 14 APB peripherals and the maximum speed of PCLK is 48MHz. APB2 contains 11 APB peripherals with a maximum PCLK speed equal to 48MHz.

### 2.1.2 Bus Address Mapping

The address mapping includes all AHB and APB peripherals: AHB peripherals, APB1 peripherals, APB2 peripherals, Flash, SRAM, System Memory, etc. The specific mapping is as follows:

**Figure 2-2 Bus Address Map**



**Table 2-1 List of Peripheral Register Addresses**

| Address range             | Peripherals           | Bus  |
|---------------------------|-----------------------|------|
| 0x4002_8400 – 0x5FFF_FFFF | Reserved              | AHB  |
| 0x4002_8000 – 0x4002_83FF | HDIV                  |      |
| 0x4002_3400 – 0x4002_7FFF | Reserved              |      |
| 0x4002_3000 – 0x4002_33FF | CRC                   |      |
| 0x4002_2400 – 0x4002_2FFF | Reserved              |      |
| 0x4002_2000 – 0x4002_23FF | Flash                 |      |
| 0x4002_1400 – 0x4002_1FFF | Reserved              |      |
| 0x4002_1000 – 0x4002_13FF | RCC                   |      |
| 0x4002_0C00 – 0x4002_0FFF | Reserved              |      |
| 0x4002_0800 – 0x4002_0BFF | ADC                   |      |
| 0x4002_0400 – 0x4002_07FF | SQRT                  |      |
| 0x4002_0000 – 0x4002_03FF | DMA                   |      |
| 0x4001_8000 – 0x4001_FFFF | Reserved              |      |
| 0x4001_4800 – 0x4001_7FFF | Reserved              |      |
| 0x4001_4400 – 0x4001_47FF | SPI2                  |      |
| 0x4001_3C00 – 0x4001_43FF | Reserved              |      |
| 0x4001_3800 – 0x4001_3BFF | USART1                |      |
| 0x4001_3400 – 0x4001_37FF | TIM8                  |      |
| 0x4001_3000 – 0x4001_33FF | Reserved              |      |
| 0x4001_2C00 – 0x4001_2FFF | TIM1                  |      |
| 0x4001_2400 – 0x4001_2BFF | Reserved              |      |
| 0x4001_2000 – 0x4001_23FF | SPI1_I <sup>2</sup> S |      |
| 0x4001_1C00 – 0x4001_1FFF | GPIOF                 |      |
| 0x4001_1400 – 0x4001_1BFF | Reserved              |      |
| 0x4001_1000 – 0x4001_13FF | GPIOC                 |      |
| 0x4001_0C00 – 0x4001_0FFF | GPIOB                 |      |
| 0x4001_0800 – 0x4001_0BFF | GPIOA                 |      |
| 0x4001_0400 – 0x4001_07FF | EXTI                  |      |
| 0x4001_0000 – 0x4001_03FF | AFIO                  | APB1 |
| 0x4000_7400 – 0x4000_FFFF | Reserved              |      |
| 0x4000_7000 – 0x4000_73FF | PWR                   |      |
| 0x4000_5C00 – 0x4000_6FFF | Reserved              |      |
| 0x4000_5800 – 0x4000_5BFF | I <sup>2</sup> C2     |      |
| 0x4000_5400 – 0x4000_57FF | I <sup>2</sup> C1     |      |
| 0x4000_4C00 – 0x4000_53FF | Reserved              |      |
| 0x4000_4800 – 0x4000_4BFF | LPUART                |      |

| Address range             | Peripherals | Bus |
|---------------------------|-------------|-----|
| 0x4000_4400 – 0x4000_47FF | USART2      |     |
| 0x4000_3400 – 0x4000_43FF | Reserved    |     |
| 0x4000_3000 – 0x4000_33FF | IWDG        |     |
| 0x4000_2C00 – 0x4000_2FFF | WWDG        |     |
| 0x4000_2800 – 0x4000_2BFF | RTC         |     |
| 0x4000_2400 – 0x4000_27FF | COMP        |     |
| 0x4000_2000 – 0x4000_23FF | OPAMP       |     |
| 0x4000_1400 – 0x4000_1FFF | Reserved    |     |
| 0x4000_1000 – 0x4000_13FF | TIM6        |     |
| 0x4000_0C00 – 0x4000_0FFF | LPTIM       |     |
| 0x4000_0800 – 0x4000_0BFF | Reserved    |     |
| 0x4000_0400 – 0x4000_07FF | TIM3        |     |
| 0x4000_0000 – 0x4000_03FF | BEEPER      |     |

### 2.1.3 Boot Management

#### 2.1.3.1 Boot address

During system startup, you can select the BOOT mode after the reset through the BOOT0 pin and the user option byte BOOT configuration. The value of the BOOT pin will be re-sampled after the system is reset or exits from the Power Down mode. After a startup delay has elapsed, the CPU fetches the top-of-stack value from address 0x0000\_0000 and executes the code from the reset vector address indicated by address 0x0000\_0004. Because of the Cortex®-M0 always gets the top-of-stack value and reset vector from addresses 0x0000\_0000 and 0x0000\_0004, so boot is only suitable for booting from the CODE area, and address remapping is designed for boot space. There are three boot modes to choose from:

- Boot from Main Flash:
  - Main Flash memory is mapped to the boot space (0x0000\_0000);
  - Main Flash memory is accessible in two address areas, 0x0000\_0000 or 0x0800\_0000;
- Boot from System Memory:
  - System Memory is mapped to boot space (0x0000\_0000);
  - System Memory can be accessed in two address areas, 0x0000\_0000 or 0x1FFF\_0000;
- Boot from the embedded SRAM:
  - The embedded SRAM is mapped to boot space (0x0000\_0000);
  - The embedded SRAM is accessible in two address areas, 0x0000\_0000 or 0x2000\_0000;

#### 2.1.3.2 Boot configuration

Three different BOOT modes can be selected through the BOOT0 pin and the user option byte BOOT configuration.



Table 2-2 List of Boot Mode

| Boot mode select pin |        |           |          | Boot mode           | Specifies the start address for accessing memory space in boot mode |                            |                            |
|----------------------|--------|-----------|----------|---------------------|---|----------------------------|----------------------------|
| nBOOT1               | nBOOT0 | BOOT0 pin | nSWBOOT0 |                     | Main Flash  | System Memory              | SRAM                       |
| X                    | X      | 0         | 1        | Main Flash start    | 0x0000_0000   | 0x1FFF_0000                | 0x2000_0000                |
| X                    | 1      | X         | 0        |                     | 0x0800_0000   |                            |                            |
| 1                    | X      | 1         | 1        | System Memory Start | 0x08000000  | 0x0000_0000<br>0x1FFF_0000 | 0x2000_0000                |
| 1                    | 0      | X         | 0        |                     |   |                            |                            |
| 0                    | X      | 1         | 1        | SRAM start          | 0x08000000  | 0x1FFF_0000                | 0x0000_0000<br>0x2000_0000 |
| 0                    | 0      | X         | 0        |                     |   |                            |                            |

Note: BOOT0 and GPIO are multiplexed, and input drop - down is used by default during power-on.

### 2.1.3.3 Embedded boot loader

The embedded boot loader is stored in System Memory for reprogramming Flash Memory through USART1. The USART1 interface can run not only with an external clock (HSE) but also with the internal 8MHz oscillator (HSI).. For further details, please refer to bootstrap manual .

## 2.2 Memory System

The program memory, data memory, registers and I/O ports are organized in the same 4GB linear address space. Data bytes are stored in the memory in Little Endian format. The lowest numbered byte in a word is regarded as the least significant byte of the word, while the highest numbered byte is the most significant byte. The specifications of program memory and data memory are as follows.

### 2.2.1 FLASH Specification

The Flash consists of a main memory block and an information block, which are described below: (The capacity value in the following description does not include ECC)

- The maximum main memory block is 64KB, also known as main Flash memory, which contains 128 pages for storing and running user programs and storing data.
- The information area is 5KB, including 10 Pages, and consists of system memory area (3KB), system configuration area (1.5KB) and option byte area (0.5KB).
  - The System Memory area is 3KB, including 6 Pages, also known as System Memory, and is used for storing and running the BOOT loader
  - The system configuration area is 1.5KB, including 3 Pages.
  - The Option Byte area is 0.5KB, including 1 Page, also known as Option Byte, with an effective space of 14B, Both the BOOT program and user programs can read, writn and erase this area.

#### 2.2.1.1 Flash memory module organization

Both the main memory block and the information block are allocated to bus address space memory

**Table 2-3 Flash Bus Address List**

| Memory Area                    | Page Name                 | Address Range             | Size   |
|--------------------------------|---------------------------|---------------------------|--------|
| The main memory area           | Page 0                    | 0x0800_0000 – 0x0800_01FF | 0.5 KB |
|                                | Page 1                    | 0x0800_0200 – 0x0800_03FF | 0.5 KB |
|                                | Page 2                    | 0x0800_0400 – 0x0800_05FF | 0.5 KB |
|                                | ⋮                         | ⋮                         | ⋮      |
|                                | Page 127                  | 0x0800_FE00 – 0x0800_FFFF | 0.5 KB |
| Information area               | System memory area        | 0x1FFF_0000 – 0x1FFF_0BFF | 3KB    |
|                                | System configuration area | 0x1FFF_F000 – 0x1FFF_F5FF | 1.5 KB |
|                                | Option byte area          | 0x1FFF_F600 – 0x1FFF_F60D | 14B    |
| Memory area interface register | FLASH_AC                  | 0x4002_2000 – 0x4002_2003 | 4B     |
|                                | FLASH_KEY                 | 0x4002_2004 – 0x4002_2007 | 4B     |
|                                | FLASH_OPTKEY              | 0x4002_2008 – 0x4002_200B | 4B     |
|                                | FLASH_STS                 | 0x4002_200C – 0x4002_200F | 4B     |
|                                | FLASH_CTRL                | 0x4002_2010 – 0x4002_2013 | 4B     |
|                                | FLASH_ADD                 | 0x4002_2014 – 0x4002_2017 | 4B     |
|                                | Reserved                  | 0x4002_2018 – 0x4002_201B | 4B     |
|                                | FLASH_OB                  | 0x4002_201C – 0x4002_201F | 4B     |
|                                | FLASH_WRP                 | 0x4002_2020 – 0x4002_2023 | 4B     |
|                                | FLASH_ECC                 | 0x4002_2024 – 0x4002_2027 | 4B     |

The Flash memory is organized into 32-bit wide memory units, which can store codes and data constants.

Information is divided into three parts:

- The system memory area is used to store the bootloader in the system memory. The bootloader uses USART1 serial interface to program the Flash memory.
- System configuration area, contains basic information about the chip.
- The option byte area, writing to main memory and information block is managed by embedded Flash programming/erasing controller.

There are two ways to protect Flash memory from illegal access (read, write and erase):

- Page write protection (WRP)
- Page readout protection (RDP)

When the Flash memory write operation is executed, any read operation to the Flash memory will stall the bus, and the read operation can only be performed correctly after the write operation is completed. This means that code or data fetches cannot be made while a program/erase operation is ongoing.

When performing Flash programming operations (write or erase), the internal RC oscillator (HSI) must be turned on .

*Note: In the low power consumption mode, all Flash memory operations are suspended.*

### 2.2.1.2 Read and write operation

The Flash operation only supports 32-bit operation, and the Flash should be erased before the write operation, and the minimum block size for erasing is one page 0.5KB. Write operation is divided into erasing and programming phases.

When reading Flash, the number of waiting cycles for reading can be configured by the register. When using, it needs to be calculated in combination with the clock frequency of SYSCLK interface. For example, when  $\text{SYSCLK} \leq 18\text{MHz}$ , the minimum number of waiting periods is 0; When  $18\text{MHz} < \text{SYSCLK} \leq 36\text{MHz}$ , the minimum number of waiting periods is 1; When  $36\text{MHz} < \text{SYSCLK} \leq 48\text{MHz}$ , the minimum number of waiting periods is 2.

*Note: Whether number of wait periods is not zero, enable prefetch buffer can improve overall efficiency.*

### 2.2.1.3 Unlock Flash

After reset, the Flash module is protected and cannot be written into the FLASH\_CTRL register to prevent accidental operation of Flash memory due to electrical disturbances and other reasons. By writing a specific sequence of key values into the FLASH\_KEY register, you can unlock the FLASH\_CTRL register. The specific sequence is: Firstly, writing KEY1 = 0x45670123 in the FLASH\_KEY register. Secondly, writing the key value KEY2 = 0xCDEF89AB in the FLASH\_KEY register.

If there is an error in sequence or key value, a bus error will be returned and the FLASH\_CTRL register will be locked until the next reset.

Software can check the FLASH\_CTRL.LOCK bit to confirm whether the Flash is unlocked. If normal locking is required, software can set the FLASH\_CTRL.LOCK bit to 1. After that, the Flash can be unlocked by writing the correct key sequence to the FLASH\_KEY register.

### 2.2.1.4 Erase and program

#### 2.2.1.4.1 Erase of main memory area

The main memory area can be erased page by page or whole.

- **Page Erase**

Page Erase process:

- Check the FLASH\_STS.BUSY bit to confirm that there are no other Flash operations in progress;
- Set the FLASH\_CTRL.PER bit to '1';
- Select the page to be erased with the FLASH\_ADD register;
- Set the FLASH\_CTRL.START bit to '1';
- Wait for the FLASH\_STS.BUSY bit to change to '0';
- Read out the content of the erased page and verify it.

- **Mass Erase**

Mass Erase process:

- Check the FLASH\_STS.BUSY bit to confirm that there are no other Flash operations in progress;
- Set the FLASH\_CTRL.MER bit to '1';

- Set the FLASH\_CTRL.START bit to '1';
- Wait for the FLASH\_STS.BUSY bit to change to '0';
- Read out all pages and verify them.

#### 2.2.1.4.2 Main memory area programming

The main memory block can be programmed with 32 bits at a time. When the FLASH\_CTRL.PG bit is '1', writing a word in a Flash address will start programming once; Writing any half word of data will result in a bus error. During the programming process (the FLASH\_STS.BUSY bit is '1'), any operation of reading or writing the Flash memory will cause the CPU to pause until the end of the Flash programming.

Main memory programming process:

- Check the FLASH\_STS.BUSY bit to confirm that there are no other Flash operations in progress;
- Set the FLASH\_CTRL.PG bit to '1';
- Write the word to be programmed at the specified address;
- Wait for the FLASH\_STS.BUSY bit to change to '0';
- Read the written address and verify the data.

*Note: When the FLASH\_STS.BUSY bit is '1', you cannot write to any register.*

#### 2.2.1.4.3 Option byte erase and programming

The option byte area is programmed differently from the main memory block. The number of option bytes is limited to 7 bytes (2 bytes for write protection, 2 bytes for readout protection, 1 byte for configuration and 2 bytes for storing user data). After unlocking the Flash, you must write KEY1 and KEY2 respectively (refer to 2.2.1.3) to the FLASH\_OPTKEY register, and then set the FLASH\_CTRL.OPTWE bit to '1'. At this time, the option byte area can be programmed: set the FLASH\_CTRL.OPTPG bit to '1' and then write a word to the specified address.

When programming the word in the option byte area, use the low byte in the half-word and automatically calculate the high byte (the high byte is the complement of the low byte), before starting the programming operation, this ensures that the option byte and its complement are always correct.

Option byte erase process:

- Check the FLASH\_STS.BUSY bit to confirm that there are no other Flash operations in progress;
- Unlock the FLASH\_CTRL.OPTWE bit;
- Set the FLASH\_CTRL.OPTER bit to '1';
- Set the FLASH\_CTRL.START bit to '1';
- Wait for the FLASH\_STS.BUSY bit to change to '0';
- Read the erased option byte and verify it.

Option byte area programming process:

- Check the FLASH\_STS.BUSY bit to confirm that there are no other Flash operations in progress;

- Set the FLASH\_CTRL.OPTWE bit to '1';
- Set the FLASH\_CTRL.OPTPG bit to '1';
- Writing the word to be programmed to the specified address;
- Wait for the FLASH\_STS.BUSY bit to change to '0';
- Read the written address and verify the data.

#### 2.2.1.5 ECC function

The Flash module supports the ECC functionality, enabling 1-bit error detection and correction. ECC encoding and decoding (error correction and error detection) are performed automatically by the hardware. If an error is detected, an error is set and an interrupt is generated.

#### 2.2.1.6 Instruction prefetching

The Flash module supports instruction prefetch function with the prefetch buffer size of 8B. Through instruction prefetching, the instruction execution efficiency of CPU can be improved. The instruction prefetch function can be configured to be enabled or disabled through the register, and it is enabled by default.

#### 2.2.1.7 Option byte

Option byte block is mainly used to configure read-write protection, boot mode configuration, software/hardware watchdog and reset options when the system is in PD or STOP mode, and bus address space is allocated to the option byte block for read-write access. They consist of 7 options bytes : 2 byte for write protection, 2 bytes for readout protection, 1 byte for configuration option, 2 bytes defined by user. The option byte block also contains the complement codes corresponding to these 7 option bytes. These complement codes need to be automatically calculated by hardware when the option bytes are written in the bus, and written into Flash together, and used for verification when the option bytes are read.

By default, the option byte block is always read-accessible and write-protected. To write (program/erase) the option byte block, first unlock the Flash, then unlock the option byte: write the correct key-value sequence (KEY1 = 0x45670123, KEY2 = 0xCDEF89AB) into the FLASH\_OPTKEY, and then write operation to the option byte block will be allowed. If the sequence is wrong or the key value is wrong, a bus error will be returned and the option byte will be locked until the next reset. To lock the option byte normally, write '0' to the FLASH\_CTRL.OPTWE bit by software, and then the option byte can be unlocked by writing the correct key value sequence in the FLASH\_OPTKEY.

After each system reset, the option byte data is read out from the option byte block and stored it in the option byte register (FLASH\_OB/FLASH\_WRP) with read-only property. At the same time, the option byte complement data read out together will be used to verify whether the option byte data is correct. If it does not match, an option byte error flag (FLASH\_OB.OBERR) will be generated. When an option byte error occurs, the corresponding option byte is forced to 0xFF. When the option byte and its complement are both 0xFF (the state after erasing), the above verification steps are skipped and verification is not required.

Table 2-4 Option Byte List

| Address     | [31:24]<br>Corresponding<br>complement code | [23:16]<br>Option byte | [15:8]<br>Corresponding<br>complement code | [7:0]<br>Option byte |
|-------------|---|------------------------|--|----------------------|
| 0x1FFF_F600 | nUSER                                       | USER                   | nRDP1                                      | RDP1                 |
| 0x1FFF_F604 | nData1                                      | Data1                  | nData0                                     | Data0                |
| 0x1FFF_F608 | nWRP1                                       | WRP1                   | nWRP0                                      | WRP0                 |
| 0x1FFF_F60C | Reserved                                    | Reserved               | nRDP2                                      | RDP2                 |

- Readout protection L1 level option byte: RDP1
  - Protect the code stored in the Flash memory;
  - When the correct value is written, it is not allowed to read the Flash memory;
  - The result of whether RDP1 is turned on or not can be inquired through FLASH\_OB[1];
- User configuration options: USER
  - The USER [7:6]: Reserved;
  - USER[5]: nSWBOOT0\_SEL configuration option, which can be queried by FLASH\_OB[7]
    - 0: nBOOT0 configuration option used for BOOT mode selection
    - 1: BOOT0 Pin is used to select the BOOT mode
  - USER[4]: nBOOT1 configuration option, which can be queried by FLASH\_OB[6]
  - USER[3]: nBOOT0 configuration option, which can be queried by FLASH\_OB[5]
  - USER[2]: nRST\_PD configuration option, which can be queried through FLASH\_OB[4]
    - 0: A reset occurs when PD mode is entered
    - 1: No reset occurs when entering PD mode
  - USER[1]: nRST\_STOP configuration option, which can be queried through FLASH\_OB[3]
    - 0: A reset occurs when entering STOP mode
    - 1: No reset occurs when entering the STOP mode
  - USER[0]: WDG\_SW configuration option, which can be queried by FLASH\_OB[2]
    - 0: Hardware watchdog
    - 1: Software watchdog
- 2 bytes of user data: Datax
  - Data1 (stored in FLASH\_OB[25:18]);
  - Data0 (stored in FLASH\_OB [17:10]);
- Write protection option byte: WRP0 ~ 1, which can be inquired through the register FLASH\_WRP [15:0]

- WRP0: Write protection for pages 0 to 63, bit[0] corresponds to Page (0 to 7)..., bit[7] corresponds to Page (56~63);
- WRP1: Write protection for pages 64~127, bit[0] corresponds to Page (64~71)..., bit[7] corresponds to Page (120~127);
- Readout protection L2 level option byte: RDP2
  - Add protection function on the basis of L1, refer to the detailed description of readout protection in section 2.2.1.9;
  - The result of whether RDP2 is turned on or not can be inquired through FLASH\_OB [31];

**2.2.1.8 Write protection**

Write protection can be configured for all pages of the Flash main memory area (maximum 64KB), to prevent accidental write operations caused by programcrashes or electrical disturbances. The basic unit of write protection is as follows: for Page 0 to 127, every 8 pages is a basic protection unit. Write protection can be configured by setting WRP0 andWRP1 in the option byte block; After each configuration, a system reset is required for the configured value to be reloaded to take effect. If an attempt is made to program or erase a protected page, a protection error flag will be returned in the FLASH\_STS.

The system information area contains the following blocks:

- The system memory block (3KB) in the system information area stores the boot program and cannot be changed.
- The system configuration block (1.5KB) in the system information area stores the basic information of the chip and cannot be changed.
- The option byte block (0.5KB) in the system information area stores the user-configurable option byte information. The write protection of the option byte block is achieved by writing 0 to the FLASH\_CTRL.OPTWE bit by software, and after that, you can write the correct key value sequence to FLASH\_OPTKEY to release the write protection of the option byte.

**2.2.1.9 Readout protection**

The user code in Flash can be protected against unauthorized reading by setting readout protection. Readout protection is set by configuring RDP bytes in the option byte block. Three different readout protection levels can be configured, as shown in the following Table

**Table 2-5 Read Protection Configuration List**

| Read Protection Status | RDP1                               | nRDP1 | nRDP2                         | RDP2 |
|------------------------|------------------------------------|-------|-------------------------------|------|
| L1 level               | 0xFF                               | 0xFF  | RDP2! = 0xCC    nRDP2! = 0x33 |      |
| Unprotected            | 0xA5                               | 0x5A  | RDP2! = 0xCC    nRDP2! = 0x33 |      |
| L2 level               | 0xFF                               | 0xFF  | 0x33                          | 0xCC |
| L1 level               | Not the above three configurations |       |                               |      |

- L0 level:
  - In unprotected state(RDP1 == 0xA5 & nRDP1 == 0x5A) && (RDP2!= 0xCC | nRDP2!= 0x33);
  - The main memory area and option bytes can be read arbitrarily;
  - The main memory area and options bytes can be programmed and erase, with configurable read/write protection.

- L1 level:
  - The corresponding  $\sim ((RDP1 == 0xA5 \& nRDP1 == 0x5A) \&\& (RDP2 != 0xCC \mid nRDP2 != 0x33)) \mid (RDP2 == 0xCC \& nRDP2 == 0x33)$ ;
  - Only the read operation of the main memory area from the user code is allowed, that is, the read operation of the main memory area is permitted only when the program is started from the main Flash memory in non debugging mode;
  - All main memory pages can be programmed by code executed in main Flash memory (for functions such as IAP or data memory)
  - All main memory pages are not allowed to perform write or erase operations in debug mode or after booting from internal SRAM (except for mass erase);
  - All functions of loading code into the embedded SRAM through JTAG/SWD remain effective, and they can be started from the embedded SRAM through JTAG/SWD, which can be used to remove readout protection;
  - When the read-protected option byte is rewritten to the unprotected L0 level, all the main memory areas will be automatically erased, and the process is as follows: (Erasing the option byte block will not result in automatic whole erasing operation, because the result of erasing is 0xFF, which is equivalent to remaining in the protection state of L1 level)
    - Write the correct key value sequence into FLASH\_OPTKEY to unlock the option byte block;
    - The bus initiates a command to erase the entire option byte area (Page erase);
    - Bus write 0xA5 to readout protection option byte;
    - Internally, automatically erase all main memory areas;
    - Internally, automatically write 0xA5 to readout protection option byte;
    - When the system is reset (such as software reset, etc.), the option byte block (including the new RDP value 0xA5) will be reloaded into the system, and the readout protection will be released;
- L2 level: Except that SRAM boot disabled, debug mode disabled, option byte write/page erase disabled and the protection level cannot be modified (irreversible), other features are the same as L1 level. The L2 level is realized by configuring another option byte, RDP2. No matter what the value of RDP1 is, as long as it satisfies  $(RDP2 == 0xCC \& nRDP2 == 0x33)$ , it is L2 level.

#### 2.2.1.10 Permission protection

- Flash main memory area permissions:
  - Under L0 level: the main memory area can be read; the write protection attributes for each Page can be configured in the main memory for programming and page erasing memory;
  - Under L1/2 level:
    - When executed in SWD debug mode or after booting from internal SRAM, all Pages is not allowed (W/R/PE) operations;
    - The Pages 0 to 7 are automatically write-protected, and other Pages can be programmed through the code



- executed in the main Flash memory area (implementing functions such as IAP or data memory);
- Other Pages can configure the write protection property of each Page;
- When the L1 level is modified to the L0 level, all Flash main memory areas will be automatically erased;
- Flash option byte area permission:
  - Under the L0/L1 level: all accesses are allowed (W/R/PE);
  - Under L2 level: except for debug mode, all other modes allow read-only access to the Flash option byte area.
- Flash system memory area permissions:
  - Only the code executed in the system memory area is allowed to access (W/R/PE), the code executed in Flash and SRAM, or through the debug interface, is not allowed access to the Flash system memory area.
  - Under L1/L2 level: jumping to system memory to execute code from SRAM is not allowed access to the Flash system memory area (W/R/PE); in other cases, access to the Flash system memory area is allowed (W/R/PE).
- Flash system configuration area:
  - User information: reading the area is only allowed after booting or jumping to system memory.
  - ID information: this area can be read at Level 0, access is prohibited through SWD debug mode at Level 1/L2, and access is prohibited after booting from SRAM at Level 1, refer to **Table 2-6** for details;

**Table 2-6 Flash Read-write-erase<sup>(1)</sup> Permission Control Table**

| Protect Level | Boot Mode                            | Main Flash       |                  |                  |                  | Changing A Protection Level   |
|---------------|--------------------------------------|------------------|------------------|------------------|------------------|-------------------------------|
|               | Perform user Access area             | SWD              | Main Flash       | System Memory    | SRAM             |                               |
| L0 level      | Before 4KB of Flash main memory area | Read-Write-Erase | Read-Write-Erase | Read-Write-Erase | Read-Write-Erase | Change to L1 or L2 is allowed |
|               | After 4KB of Flash main memory area  | Read-Write-Erase | Read-Write-Erase | Read-Write-Erase | Read-Write-Erase |                               |
|               | Flash main memory area mass erase    | Allow            | Allow            | Allow            | Allow            |                               |
|               | Flash option byte area               | Read-Write-Erase | Read-Write-Erase | Read-Write-Erase | Read-Write-Erase |                               |
|               | Flash system                         | prohibit         | prohibit         | Read-Write-      | prohibit         |                               |

|          | memory area                          |                                   |                  | Erase            |                  |   |
|----------|--------------------------------------|-----------------------------------|------------------|------------------|------------------|---|
|          | SRAM (All)                           | Read and write                    | Read and write   | Read and write   | Read and write   |   |
| L1 level | Before 4KB of Flash main memory area | Prohibit                          | Read-only        | Read-only        | Read-only        | Change to L0 or L2 is allowed.<br>When changed to L0, the main memory area is automatically erased. |
|          | After 4KB of Flash main memory area  | Prohibit                          | Read-Write-Erase | Read-Write-Erase | Read-Write-Erase |   |
|          | Flash main memory area mass erase    | Allow                             | Allow            | Allow            | Allow            |   |
|          | Flash option byte area               | Read-Write-Erase                  | Read-Write-Erase | Read-Write-Erase | Read-Write-Erase |   |
|          | Flash system memory area             | Prohibit                          | Prohibit         | Read-write-erase | Prohibit         |   |
|          | SRAM (All)                           | Read and write                    | Read and write   | Read and write   | Read and write   |   |
| L2 level | Before 4KB of Flash main memory area | SWD<br>The interface is disabled. | Read-only        | Read-only        | Read-only        | No modification is allowed.   |
|          | After 4KB of Flash main memory area  |                                   | Read-write-erase | Read-write-erase | Read-write-erase |   |
|          | Flash main memory area mass erase    |                                   | Allow            | Allow            | Allow            |   |
|          | Flash option byte area               |                                   | Read-only        | Read-only        | Read-only        |   |
|          | Flash system memory area             |                                   | Prohibit         | Read-write-erase | Prohibit         |   |
|          | SRAM (All)                           |                                   | Read and write   | Read and write   | Read and write   |   |

| protect level | Boot mode                            | SRAM             |                  |                  |                  | Changing a Protection Level  |
|---------------|--------------------------------------|------------------|------------------|------------------|------------------|--|
|               | Perform user Access to areas         | SWD              | Main Flash       | System Memory    | SRAM             |  |
| L0 level      | Before 4KB of Flash main memory area | Read-write-erase | Read-write-erase | Read-write-erase | Read-write-erase | Change to L1 or L2 is allowed  |
|               | After 4KB of Flash main memory area  | Read-write-erase | Read-write-erase | Read-write-erase | Read-write-erase |  |
|               | Flash main memory area mass erase    | Allow            | Allow            | Allow            | Allow            |  |
|               | Flash option byte area               | Read-write-erase | Read-write-erase | Read-write-erase | Read-write-erase |  |
|               | Flash system memory area             | Prohibit         | Prohibit         | Read-write-erase | Prohibit         |  |
|               | SRAM (All)                           | Read and write   | Read and write   | Read and write   | Read and write   |  |
| L1 level      | Before 4KB of Flash main memory area | Prohibit         | Read-only        | Read-only        | Prohibit         | Change to L0 or L2 is allowed. When changed to L0, the main memory area is automatically erased. |
|               | After 4KB of Flash main memory area  | Prohibit         | Read-write-erase | Read-write-erase | Prohibit         |  |
|               | Flash main memory area mass erase    | Allow            | Allow            | Allow            | Allow            |  |
|               | Flash option byte area               | Read-write-erase | Read-write-erase | Read-write-erase | Read-write-erase |  |
|               | Flash system memory area             | Prohibit         | Prohibit         | Prohibit         | Prohibit         |  |
|               | SRAM (All)                           | Read and         | Read and         | Read and write   | Read and         |  |

|               |                                      |  |                  |                         |                  |   |
|---------------|--------------------------------------|--|------------------|-------------------------|------------------|---|
|               |                                      | write                                      | write            |                         | write            |   |
| L2 level      | Before 4KB of Flash main memory area | L2 protection level, cannot boot from SRAM |                  |                         |                  | No modification is allowed.<br>SWD is banned. |
|               | After 4KB of Flash main memory area  |  |                  |                         |                  |   |
|               | Flash main memory area mass erase    |  |                  |                         |                  |   |
|               | Flash option byte area               |  |                  |                         |                  |   |
|               | Flash system memory area             |  |                  |                         |                  |   |
|               | SRAM (All)                           |  |                  |                         |                  |   |
|               |                                      |  |                  |                         |                  |   |
| protect level | Boot mode                            | System Memory                              |                  |                         |                  | Changing a Protection Level                   |
|               | Perform user Access to areas         | SWD  | Jump to Flash    | System Memory Start the | Jump to SRAM     |   |
| L0 level      | Before 4KB of Flash main memory area | Read-write-erase                           | Read-write-erase | Read-write-erase        | Read-write-erase | Change to L1 or L2 is allowed                 |
|               | After 4KB of Flash main memory area  | Read-write-erase                           | Read-write-erase | Read-write-erase        | Read-write-erase |   |
|               | Flash main memory area mass erase    | Allow                                      | Allow            | Allow                   | Allow            |   |
|               | Flash option byte area               | Read-write-erase                           | Read-write-erase | Read-write-erase        | Read-write-erase |   |
|               | Flash system memory area             | Prohibit                                   | Prohibit         | Read-write-erase        | Prohibit         |   |

|          | SRAM (All)                           | Read and write                    | Read and write   | Read and write   | Read and write   |   |
|----------|--------------------------------------|-----------------------------------|------------------|------------------|------------------|---|
| L1 level | Before 4KB of Flash main memory area | Prohibit                          | Read-only        | Read-only        | Read-only        | Change to L0 or L2 is allowed.<br>When changed to L0, the main memory area is automatically erased. |
|          | After 4KB of Flash main memory area  | Prohibit                          | Read-write-erase | Read-write-erase | Read-write-erase |   |
|          | Flash main memory area mass erase    | Allow                             | Allow            | Allow            | Allow            |   |
|          | Flash option byte area               | Read-write-erase                  | Read-write-erase | Read-write-erase | Read-write-erase |   |
|          | Flash system memory area             | Prohibit                          | Prohibit         | Read-write-erase | Prohibit         |   |
|          | SRAM (All)                           | Read and write                    | Read and write   | Read and write   | Read and write   |   |
| L2 level | Before 4KB of Flash main memory area | SWD<br>The interface is disabled. | Read-only        | Read-only        | Read-only        | No modification allowed   |
|          | After 4KB of Flash main memory area  |                                   | Read-write-erase | Read-write-erase | Read-write-erase |   |
|          | Flash main memory area mass erase    |                                   | Allow            | Allow            | Allow            |   |
|          | Flash option byte area               |                                   | Read-only        | Read-only        | Read-only        |   |
|          | Flash system memory area             |                                   | Prohibit         | Read-write-erase | Prohibit         |   |
|          | SRAM (All)                           |                                   | Read and write   | Read and write   | Read and write   |   |

Note: <sup>(1)</sup>Erase here refers to Flash page erase.

## 2.2.2 SRAM

SRAM is mainly used for operation to store variables and data or stacks during program execution. The maximum capacity is 8KB.

SRAM supports read-write access of byte, half-word and word.

SRAM supports code execution and can run programs at full speed in SRAM. The maximum address range of SRAM is 0x2000 0000 to 0x2000 1FFF.

In PD mode, data cannot be retained in SRAM; in other operating modes (RUN/LPRUN/SLEEP/STOP), data can be retained normally. The main features are as follows:

- The maximum capacity is 8KB in total.
- Supports byte/half word/word reading and writing.
- CPU/DMA can be accessed.
- The CPU BUS can be remapped to SRAM to run the program at full speed.

## 2.2.3 FLASH Register Description

All register operations must be performed in words (32 bits).

### 2.2.3.1 Flash register overview

**Table 2-7 Flash Register Overview**

| Offset | Register     | 31       | 30       | 29 | 28 | 27 | 26    | 25 | 24 | 23 | 22 | 21 | 20    | 19 | 18 | 17 | 16 | 15 | 14       | 13        | 12     | 11       | 10      | 9         | 8        | 7       | 6        | 5        | 4       | 3        | 2     | 1        | 0    |
|--------|--------------|----------|----------|----|----|----|-------|----|----|----|----|----|-------|----|----|----|----|----|----------|-----------|--------|----------|---------|-----------|----------|---------|----------|----------|---------|----------|-------|----------|------|
| 000h   | FLASH_AC     | Reserved |          |    |    |    |       |    |    |    |    |    |       |    |    |    |    |    |          |           |        |          |         |           |          | PRFTBFS | PRFTBFE  | Reserved | LATENCY |          |       |          |      |
|        | Reset Value  |          |          |    |    |    |       |    |    |    |    |    |       |    |    |    |    |    |          |           |        |          |         |           |          | 1       | 1        |          | 0       | 0        | 0     |          |      |
| 004h   | FLASH_KEY    | FKEY     |          |    |    |    |       |    |    |    |    |    |       |    |    |    |    |    |          |           |        |          |         |           |          |         |          |          |         |          |       |          |      |
|        | Reset Value  | 0        | 0        | 0  | 0  | 0  | 0     | 0  | 0  | 0  | 0  | 0  | 0     | 0  | 0  | 0  | 0  | 0  | 0        | 0         | 0      | 0        | 0       | 0         | 0        | 0       | 0        | 0        | 0       | 0        | 0     | 0        |      |
| 008h   | FLASH_OPTKEY | OPTKEY   |          |    |    |    |       |    |    |    |    |    |       |    |    |    |    |    |          |           |        |          |         |           |          |         |          |          |         |          |       |          |      |
|        | Reset Value  | 0        | 0        | 0  | 0  | 0  | 0     | 0  | 0  | 0  | 0  | 0  | 0     | 0  | 0  | 0  | 0  | 0  | 0        | 0         | 0      | 0        | 0       | 0         | 0        | 0       | 0        | 0        | 0       | 0        | 0     | 0        |      |
| 00Ch   | FLASH_STS    | Reserved |          |    |    |    |       |    |    |    |    |    |       |    |    |    |    |    |          |           |        |          |         |           |          | ECCERR  | Reserved | EOP      | WRPERR  | Reserved | PGERR | Reserved | BUSY |
|        | Reset Value  |          |          |    |    |    |       |    |    |    |    |    |       |    |    |    |    |    |          |           |        |          |         |           |          | 0       |          | 0        |         |          | 0     |          | 0    |
| 010h   | FLASH_CTRL   | Reserved |          |    |    |    |       |    |    |    |    |    |       |    |    |    |    |    |          | ECCERRITE | EOPITE | Reserved | ERRITE  | OPTWE     | Reserved | LOCK    | START    | OPTER    | OPTPG   | Reserved | MER   | PER      | PG   |
|        | Reset Value  |          |          |    |    |    |       |    |    |    |    |    |       |    |    |    |    |    |          | 0         | 0      |          | 0       | 0         |          | 1       | 0        | 0        | 0       |          | 0     | 0        | 0    |
| 014h   | FLASH_ADD    | FADD     |          |    |    |    |       |    |    |    |    |    |       |    |    |    |    |    |          |           |        |          |         |           |          |         |          |          |         |          |       |          |      |
|        | Reset Value  | 0        | 0        | 0  | 0  | 0  | 0     | 0  | 0  | 0  | 0  | 0  | 0     | 0  | 0  | 0  | 0  | 0  | 0        | 0         | 0      | 0        | 0       | 0         | 0        | 0       | 0        | 0        | 0       | 0        | 0     |          |      |
| 018h   | Reserved     |          |          |    |    |    |       |    |    |    |    |    |       |    |    |    |    |    |          |           |        |          |         |           |          |         |          |          |         |          |       |          |      |
| 01Ch   | FLASH_OB     | RDPRT2   | Reserved |    |    |    | Data1 |    |    |    |    |    | Data0 |    |    |    |    |    | Not Used | nSWBOOT0  | nBOOT1 | nBOOT0   | nRST_PD | nRST_STOP | WDG_SW   | RDPRT1  | OBERR    |          |         |          |       |          |      |

| Offset | Register    | 31       | 30 | 29 | 28 | 27 | 26 | 25 | 24 | 23 | 22 | 21 | 20 | 19 | 18 | 17 | 16 | 15   | 14 | 13 | 12 | 11 | 10 | 9 | 8 | 7   | 6 | 5 | 4 | 3 | 2 | 1 | 0 |
|--------|-------------|----------|----|----|----|----|----|----|----|----|----|----|----|----|----|----|----|------|----|----|----|----|----|---|---|-----|---|---|---|---|---|---|---|
|        | Reset Value | 0        |    |    |    |    |    | 1  | 1  | 1  | 1  | 1  | 1  | 1  | 1  | 1  | 1  | 1    | 1  | 1  | 1  | 1  | 1  | 1 | 1 | 1   | 1 | 1 | 1 | 1 | 1 | 0 | 0 |
| 020h   | FLASH_WRP   | Reserved |    |    |    |    |    |    |    |    |    |    |    |    |    |    |    | WRPT |    |    |    |    |    |   |   |     |   |   |   |   |   |   |   |
|        | Reset Value |          |    |    |    |    |    |    |    |    |    |    |    |    |    |    |    | 1    | 1  | 1  | 1  | 1  | 1  | 1 | 1 | 1   | 1 | 1 | 1 | 1 | 1 | 1 | 1 |
| 024h   | FLASH_ECC   | Reserved |    |    |    |    |    |    |    |    |    |    |    |    |    |    |    |      |    |    |    |    |    |   |   | ECC |   |   |   |   |   |   |   |
|        | Reset Value |          |    |    |    |    |    |    |    |    |    |    |    |    |    |    |    |      |    |    |    |    |    |   |   | 0   | 0 | 0 | 0 | 0 | 0 |   |   |

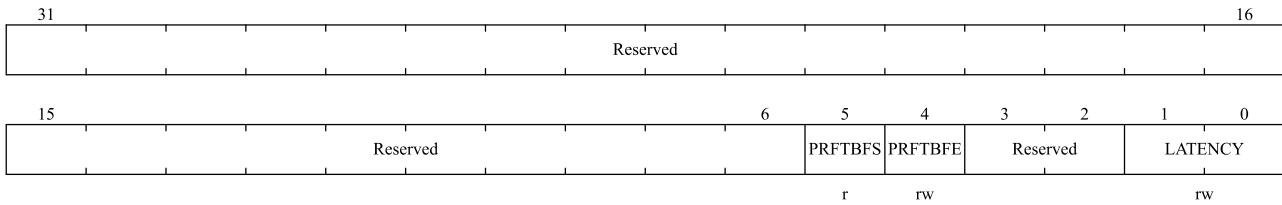
**2.2.3.2 Flash control and status registers**

For abbreviations related to register descriptions, please refer to section 1.1.

**2.2.3.3 Flash access control register (FLASH\_AC)**

Address offset: 0x00

Reset value: 0x0000 0030

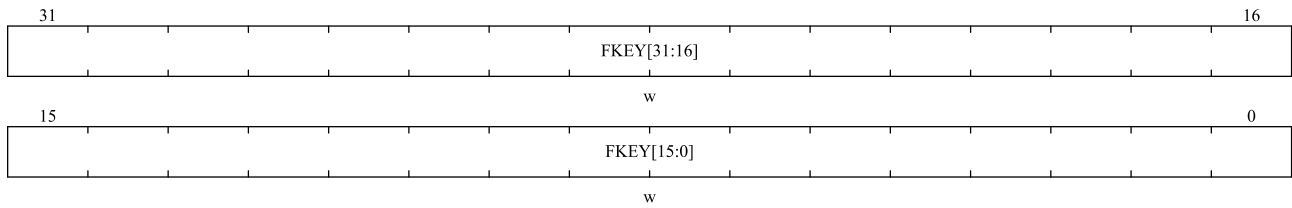


| Bit Field | Name     | Description  |
|-----------|----------|--|
| 31:6      | Reserved | Reserved, the reset value must be maintained.  |
| 5         | PRFTBFS  | Pre-fetch buffer status<br>This bit indicates the state of the pre-fetch buffer<br>0: The pre-fetch buffer is disabled.<br>1: The pre-fetch buffer is enabled.   |
| 4         | PRFTBFE  | The pre-fetch buffer is enabled<br>0: Disables the pre-fetch buffer.<br>1: Enables the pre-fetch buffer.   |
| 3:2       | Reserved | Reserved, the reset value must be maintained   |
| 1:0       | LATENCY  | Time delay<br>These bits represent the ratio of the SYSCLK (system clock) cycle to the flash access time<br>00: Zero periodic delay, when 0 < SYSCLK ≤ 18MHz<br>01: A periodic delay, when 18MHz < SYSCLK ≤ 36MHz<br>10: Two periodic delay, when 36MHz < SYSCLK ≤ 48MHz<br>11: Reserved |

**2.2.3.3.1 Flash key register (FLASH\_KEY)**

Address offset: 0x04

Reset value: 0xFFFF FFFF

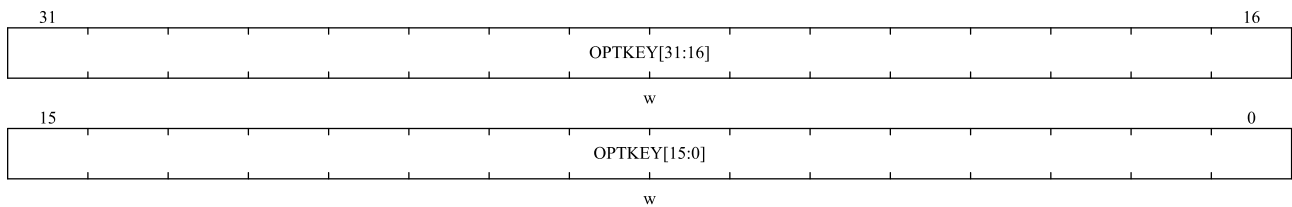


| Bit Field | Name | Description                             |
|-----------|------|---|
| 31:0      | FKEY | Used to unlock the FLASH_CTRL.LOCK bit. |

**2.2.3.3.2 Flash OPTKEY register (FLASH\_OPTKEY)**

Address offset: 0x08

Reset value: 0xXXXXX XXXX

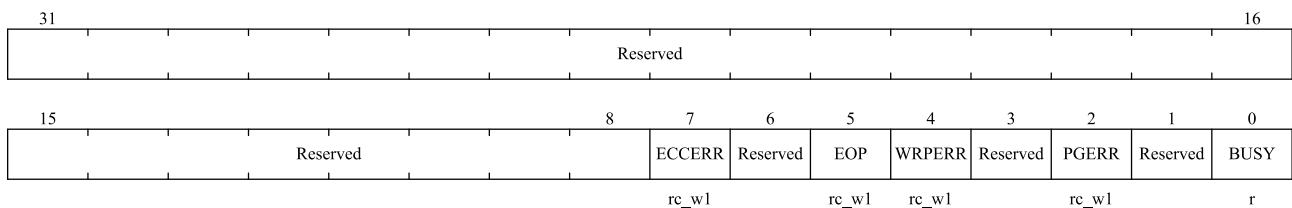


| Bit field | Name   | Description                              |
|-----------|--------|--|
| 31:0      | OPTKEY | Used to unlock the FLASH_CTRL.OPTWE bit. |

**2.2.3.3.3 Flash status register (FLASH\_STS)**

Address offset: 0x0C

Reset value: 0x0000 0000



| Bit Field | Name     | Description  |
|-----------|----------|--|
| 31:8      | Reserved | Reserved, the reset value must be maintained   |
| 7         | ECCERR   | ECC error<br>Error reading Flash, hardware set this to '1', write '1' to clear this state.   |
| 6         | Reserved | Reserved, the reset value must be maintained   |
| 5         | EOP      | End of the operation<br>When the Flash operation (programming/erasing) is complete, the hardware sets this to '1' and writing '1' clears this state.<br><i>Note: EOP status is set for each successful programming or erasure.</i> |
| 4         | WRPERR   | Write protection error   |

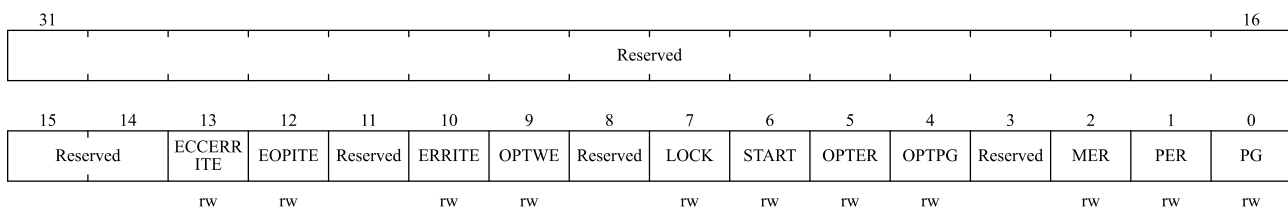


| Bit Field | Name     | Description  |
|-----------|----------|--|
|           |          | When attempting to program a write protected Flash address, hardware sets this to '1' and writing '1' clears this state.   |
| 3         | Reserved | Reserved, the reset value must be maintained   |
| 2         | PGERR    | Programming errors<br>When trying to program to an address whose content is not '0xFFFF_FFFF', the hardware sets this to '1'. Writing '1' clears this state.<br><i>Note: Before programming, the FLASH_CTRL.START bit must be cleared.</i> |
| 1         | Reserved | Reserved, the reset value must be maintained   |
| 0         | BUSY     | Busy<br>This bit indicates that a Flash operation is in progress. This bit is set to '1' at the start of the Flash operation; This bit is cleared to '0' at the end of the operation or when an error occurs.                              |

#### 2.2.3.3.4 Flash control register (FLASH\_CTRL)

Address offset: 0x10

Reset value: 0x0000 0080



| Bit Field | Name      | Description  |
|-----------|-----------|--|
| 31:14     | Reserved  | Reserved, the reset value must be maintained   |
| 13        | ECCERRITE | ECC error interrupt<br>This bit allows interrupts to occur when the FLASH_STS.ECCERR bit changes to '1'.<br>0: Forbid interruption.<br>1: Interrupts are allowed.  |
| 12        | EOPITE    | Allow operation completion interrupt.<br>This bit allows an interrupt to be generated when the FLASH_STS.EOP bit becomes '1'.<br>0: Forbid interruption.<br>1: Interrupts are allowed.                           |
| 11        | Reserved  | Reserved, the reset value must be maintained   |
| 10        | ERRITE    | Allow error status to be interrupted<br>This bit allows interrupts in the event of Flash errors (when FLASH_STS.PGERR/ FLASH_STS.WRPERR is set to '1').<br>0: Forbid interruption.<br>1: Interrupts are allowed. |

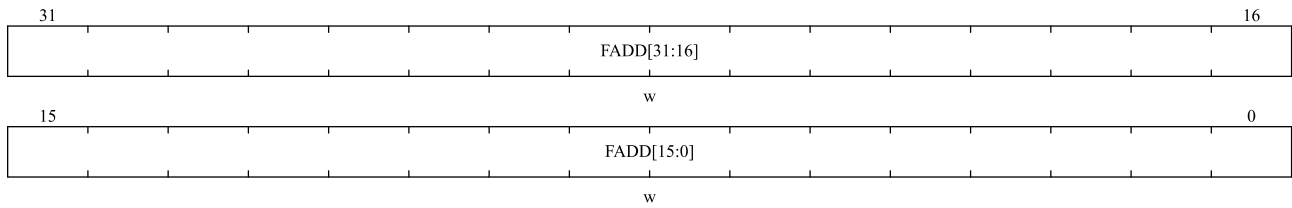
| Bit Field | Name     | Description  |
|-----------|----------|--|
| 9         | OPTWE    | Allows option bytes to be written<br>When the bit is '1', programmatic manipulation of the option byte is allowed.<br>When the correct key sequence is written to the FLASH_OPTKEY register, the bit is set to '1'.<br>Software can clear this bit.                              |
| 8         | Reserved | Reserved, the reset value must be maintained   |
| 7         | LOCK     | Lock<br>This bit can only be written as '1'. When the bit is '1', Flash and FLASH_CTRL are locked. Hardware clears this bit to '0' after detecting a correct unlock sequence.<br>After an unsuccessful unlock operation, this bit cannot be changed until the next system reset. |
| 6         | START    | Start<br>An erase operation is triggered when the bit is '1'. This bit can only be set by software to '1' and cleared to '0' when FLASH_STS.BUSY changes to '1'.   |
| 5         | OPTER    | Erase option bytes<br>0: Disable option bytes erase mode;<br>1: Enable option bytes erase mode.  |
| 4         | OPTPG    | Program option bytes<br>0: Disable option bytes program mode;<br>1: Enable option bytes program mode.  |
| 3         | Reserved | Reserved, the reset value must be maintained   |
| 2         | MER      | Mass erase<br>0: Disable mass erase mode;<br>1: Enable mass erase mode.  |
| 1         | PER      | Page erase<br>0: Disable mass erase mode;<br>1: Enable mass erase mode.  |
| 0         | PG       | Program<br>0: Disable Program mode;<br>1: Enable Program mode.   |

*Note: Please refer to Section 2.2.1.4 for programming and erasing.*

### 2.2.3.3.5 Flash address register (FLASH\_ADD)

Address offset: 0x14

Reset value: 0x0000 0000

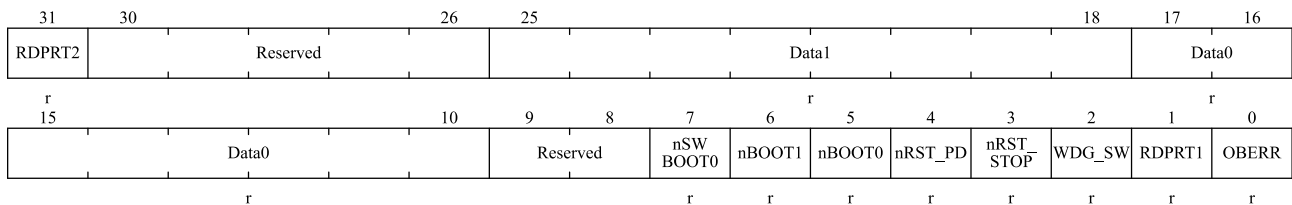


| Bit Field | Name | Description   |
|-----------|------|---|
| 31:0      | FADD | Flash memory address<br>Select the address to program when programming and the page to erase when erasing.<br><i>Note: When the FLASH_STS.BUSY bit is '1', this register cannot be written.</i> |

**2.2.3.3.6 Flash option byte register (FLASH\_OB)**

Address offset: 0x1C

Reset value: 0x03FF FFFC



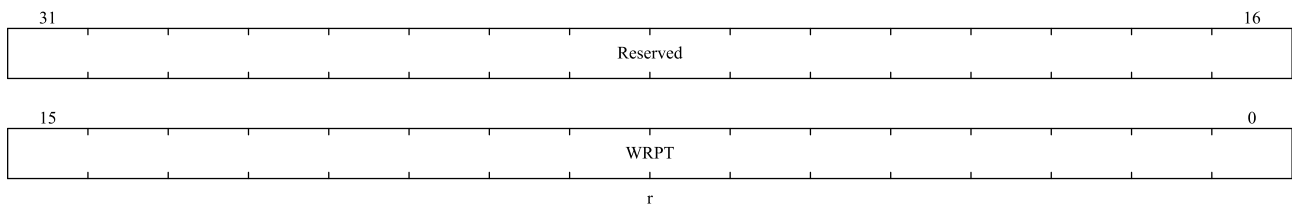
| Bit Field | Name       | Description  |
|-----------|------------|--|
| 31        | RDPRT2     | Readout protection level L2<br>0: Readout protection L2 is disabled.<br>1: Readout protection L2 is enabled.<br><i>Note: This bit is read-only.</i>  |
| 30:26     | Reserved   | Reserved, the reset value must be maintained   |
| 25:18     | Data1[7:0] | Data1<br><i>Note: This bit is read-only.</i>   |
| 17:10     | Data0[7:0] | Data0<br><i>Note: This bit is read-only.</i>   |
| 9:8       | Reserved   | Reserved, the reset value must be maintained   |
| 7         | nSWBOOT0   | For the usage rules, see 2.1.3.2 Boot configuration.   |
| 6         | nBOOT1     | For the usage rules, see 2.1.3.2 Boot configuration.   |
| 5         | nBOOT0     | For the usage rules, see 2.1.3.2 Boot configuration.   |
| 4         | nRST_PD    | The Power Down mode is used to reset the configuration<br>0: A reset occurs immediately after the system enters the Power Down mode.<br>Even if the system enters the Power Down mode, the system will be reset instead of entering the Power Down mode.<br>1: The system does not reset after entering the Power Down mode. |

| Bit Field | Name      | Description   |
|-----------|-----------|---|
|           |           | <i>Note: This bit is read-only.</i>   |
| 3         | nRST_STOP | Enter the STOP mode to reset the configuration<br>0: A reset occurs immediately after entering the STOP mode. Even if the process of entering the STOP mode is executed, the system will be reset instead of entering the STOP mode.<br>1: No reset is generated after the STOP mode is entered.<br><i>Note: This bit is read-only.</i> |
| 2         | WDG_SW    | Watchdog Settings<br>0: Hardware watchdog.<br>1: Software watchdog.<br><i>Note: This bit is read-only.</i>  |
| 1         | RDPRT1    | Readout protection level L1<br>0: The L1 level of readout protection is disabled.<br>1: L1 readout protection is enabled.<br><i>Note: This bit is read-only.</i>  |
| 0         | OBERR     | Option byte error<br>When this bit is '1', the option byte does not match its inverse.<br><i>Note: This bit is read-only.</i>   |

**2.2.3.3.7 Flash write protection register (FLASH\_WRP)**

Address offset: 0x20

Reset value: 0x0000 FFFF

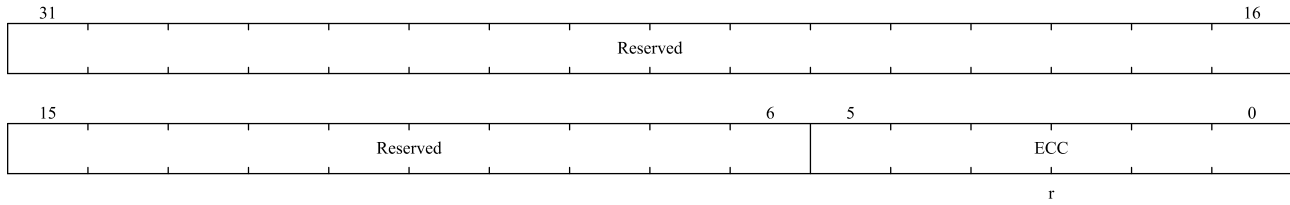


| Bit Field | Name     | Description   |
|-----------|----------|---|
| 31:16     | Reserved | Reserved, the reset value must be maintained  |
| 15:0      | WRPT     | Write protection<br>This register contains the write protection option byte loaded by option byte area.<br>0: Write protection takes effect.<br>1: Write protection is invalid.<br><i>Note: These bits are read-only.</i> |

**2.2.3.3.8 Flash ECC register (FLASH\_ECC)**

Address offset: 0x24

Reset value: 0x0000 0000



| Bit Field | Name     | Description   |
|-----------|----------|---|
| 31:6      | Reserved | Reserved, the reset value must be maintained  |
| 5:0       | ECC      | After writing a word to a 32-bit Flash address, the corresponding higher 6-bit ECC value. |

## 3 Power Control (PWR)

### 3.1 General Description

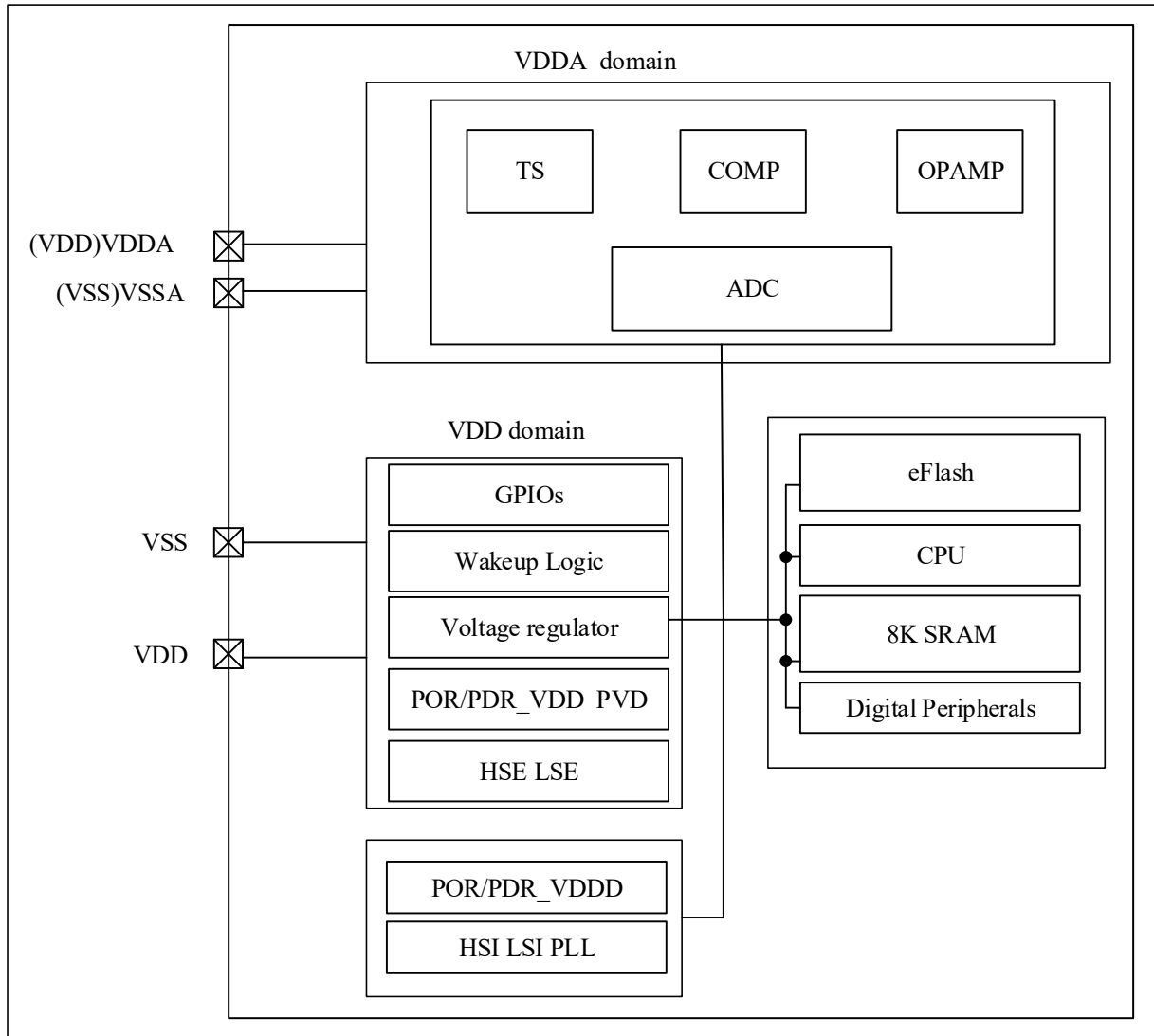
The PWR is power management unit to control status of different modules in different power modes. Its major function is to control MCU to enter different power modes and wakeup when events or interrupts happen. MCU supports the following modes: RUN, LPRUN, SLEEP, STOP and PD (Power Down) . PWR controls voltage regulator, Clock sources, Resets and Flash/SRAM/GPIO status in different power modes.

#### 3.1.1 Power Supply

- MCU has an external  $V_{DD}$  supply. Embedded voltage regulator is used to supply the internal 1.5V digital power supplies. Voltage regulator has two modes, normal mode and low power mode.
  - $V_{DD}$ : 1.8V~5.5V, which mainly provides power input for MR, IO and clock reset system.
  - $V_{DDA}$ : 1.8V~5.5V, which mainly provides power for most analog peripherals. For details, please refer to the electrical characteristics section of the relevant data sheet.
  - $V_{DDA}$  and  $V_{SSA}$  must be connected to  $V_{DD}$  and  $V_{SS}$  respectively.
- Voltage regulator operates in several different modes, depending on the application:
  - RUN mode: The voltage regulator provides power in normal power mode.
  - LPRUN mode: The voltage regulator provides power in normal power mode.
  - SLEEP mode: The voltage regulator provides power in normal power mode.

- STOP mode: The voltage regulator provides power in low power mode and the output voltage can be configured to 1.5V or 1.2V by software.
- PD mode: The voltage regulator is turned off.

**Figure 3-1 Power Supply Block Diagram**

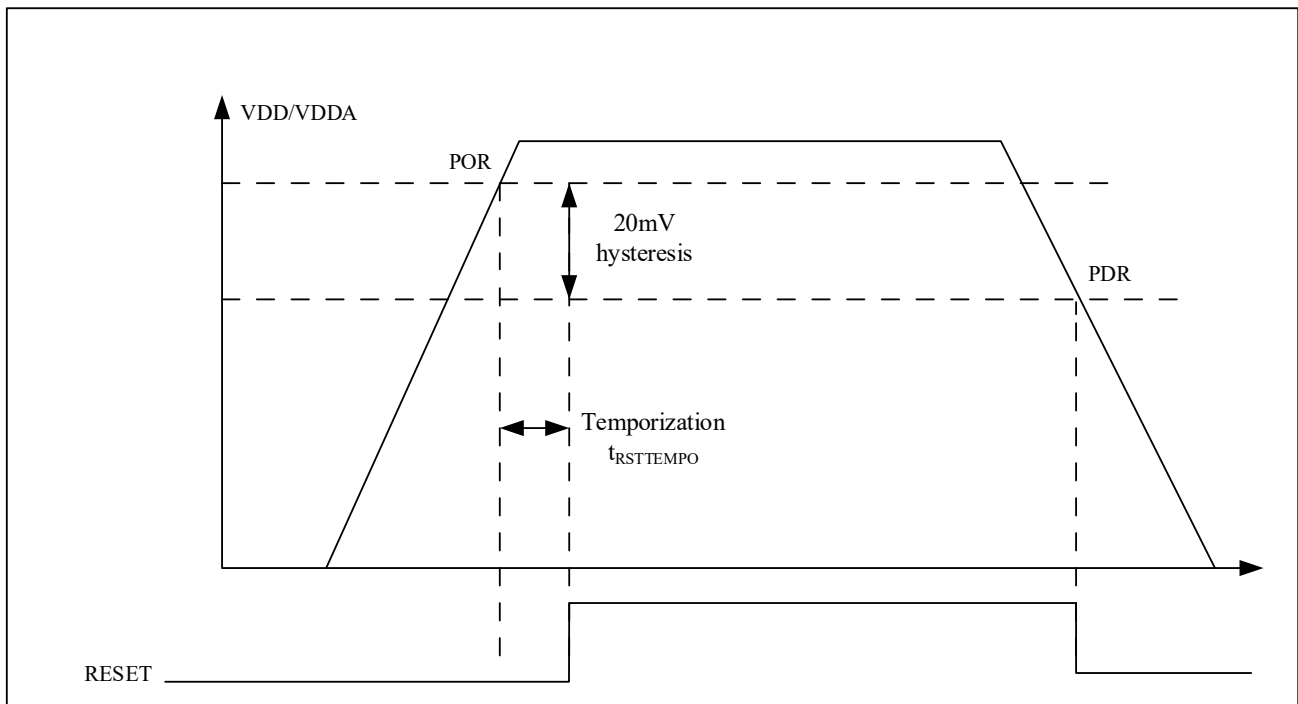


### 3.1.2 Power Supply Supervisor

#### 3.1.2.1 Power on reset (POR) and power down reset (PDR)

Power on reset (POR) and power down reset (PDR) circuits are integrated inside the chip. When  $V_{DD}/V_{DDA}$  is below the specified limit voltage  $V_{POR}/V_{PDR}$ , the system remains in a reset state without an external reset circuit. Refer to the electrical characteristics section of the data sheet for details on power-on and power-off resets.

Figure 3-2 Power on Reset/Power down Reset Waveform

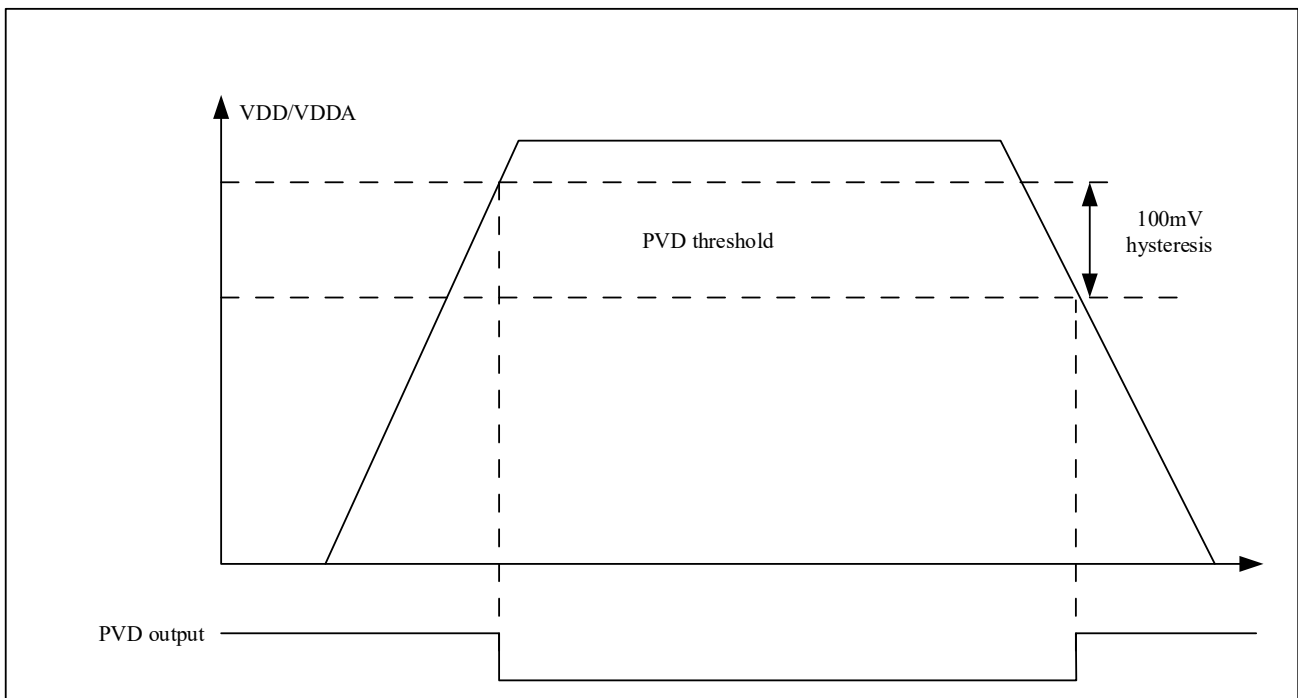


**3.1.2.2 Programmable voltage detector (PVD)**

The PVD monitors the power supply by comparing the V<sub>DD</sub> voltage with the relevant bits in the power control register (PWR\_CTRL). PWR\_CTRL.PLS select the threshold of the monitoring voltage. Enable PVD by setting the PWR\_CTRL.PVDEN.

The PWR\_CTRLSTS.PVDO flag is used to indicate whether the V<sub>DD</sub> is above/below the PVD voltage threshold. This event is connected internally to EXTI line16 and produces an interrupt if the interrupt is enabled in the external interrupt register. A PVD break occurs when the V<sub>DD</sub> drops below the PVD threshold and/or when the V<sub>DD</sub> rises above the PVD threshold, according to the rise/fall edge trigger setting of EXTI line 16. For example, this feature can be used to perform emergency shutdown tasks.

**Figure 3-3 PVD Threshold Diagram**



**3.1.3 NRST**

NRST is an analog PAD. In STOP mode, PWR detects NRST reset event and asynchronously switches voltage regulator back to normal mode.

**3.2 Power Modes**

The MCU has five power modes: RUN, LPRUN, SLEEP, STOP and PD. Different mode has different performance and power consumption. A summary of MCU power modes is shown below.

**Table 3-1 Power Modes**

| Mode               | Condition   | Enter   | Exit                                    |
|--------------------|---|---|---|
| RUN                | CPU is running<br>all peripherals are configurable.   | Power up, system reset,<br>or wakeup from other<br>power modes. | Enter LPRUN, SLEEP, STOP or<br>PD mode. |
| LPRUN from<br>SRAM | CPU runs at LSI or LSE, PLL is<br>turned off, and all peripherals are<br>configurable.<br>Voltage regulator is running in<br>normal mode.<br>Flash enter deep standby mode. | software control  | software control                        |



| Mode             | Condition   | Enter  | Exit  |
|------------------|---|--|---|
| LPRUN from Flash | CPU runs at LSI or LSE, PLL is turned off, all peripherals are configurable.<br>Voltage regulator is running in normal mode.  | software control   | software control                                      |
| SLEEP            | CPU enters sleep mode, the core is turned down;<br>all peripherals are configurable, regulator is running in normal mode;<br>Interrupts & Events can wakeup CPU.  | WFI<br>CPU returns from ISR<br>WFE   | Any interrupts wakeup event.                          |
| STOP             | CPU enters deep SLEEP, peripherals clock are disabled. Voltage regulator runs in LP mode. Flash enters deep standby mode. HSE/HSI/PLL are disabled. LSE/LSI are configurable. RTC//LPUART/LPTIM/COMP are optional. SRAM/All registers are retained All IO are retained . After waking up, HSI is enabled. | WFI/WFE:<br>1) SCB_SCR.SLEEPDE<br>EP = 1, no pending interrupts/events.<br>2) PWR_CTRL.PDSTP = 0 | Any interrupts wakeup event through EXTI, NRST, IWDG. |
| PD               | Voltage regulator is OFF, all clocks are OFF, most IO output High-Z. NRST/PA0_WKUP0/PC13_WKUP1 / PA2_WKUP2 can wake up the chip.  | WFI/WFE:<br>1) SCB_SCR.SLEEPDE<br>EP = 1, no pending interrupt/event.<br>2) PWR_CTRL.PDSTP = 1   | WKUP0/1/2 rising or falling edge, NRST reset.         |

Note: In STOP mode, after wakeup, the code can resume and continue from stopped location.

The operating enabled status of different modules in different power consumption modes are shown in the following table:

**Table 3-2 Peripheral Running Status**

| Peripheral              | Run/Active | Sleep | Low Power Run | Stop Mode |                   | Power Down Mode |                   |
|-------------------------|------------|-------|---------------|-----------|-------------------|-----------------|-------------------|
|                         |            |       |               | Status    | Wakeup Capability | Status          | Wakeup Capability |
| Cortex <sup>®</sup> -M0 | Y          | -     | Y             | -         | -                 | -               | -                 |
| Flash                   | O          | O     | O             | O         | -                 | -               | -                 |

|                    |   |   |   |   |   |   |        |
|--------------------|---|---|---|---|---|---|--------|
| SRAM8KB            | Y | Y | Y | Y | - | - | -      |
| POR/PDR            | Y | Y | Y | Y | Y | - | -      |
| PVD                | O | O | O | O | O | - | -      |
| DMA                | O | O | O | - | - | - | -      |
| USART/UART         | O | O | O | - | - | - | -      |
| LPUART             | O | O | O | O | O | - | -      |
| I <sup>2</sup> C   | O | O | O | - | - | - | -      |
| SPI                | O | O | O | - | - | - | -      |
| CAN                | O | O | O | - | - | - | -      |
| RTC                | O | O | O | O | O | - | -      |
| TIMER              | O | O | O | - | - | - | -      |
| LPTIMER            | O | O | O | O | O |   |        |
| HSE                | O | O | - | - | - | - | -      |
| HSI                | O | O | - | - | - | - | -      |
| LSE                | O | O | O | O | - | - | -      |
| LSI                | O | O | O | O | - | - | -      |
| PLL                | O | O | - | - | - | - | -      |
| IWDG               | O | O | O | O | O | - | -      |
| WWDG               | O | O | O | - | - | - | -      |
| ADC                | O | O | - | - | - | - | -      |
| Temperature Sensor | O | O | O | - | - | - | -      |
| OPA                | O | O | O | - | - | - | -      |
| LPCOMP             | O | O | O | O | O |   |        |
| SysTick timer      | O | O | O | - | - |   |        |
| CRC                | O | O | O | - | - | - | -      |
| HDIV/SQRT          | O | O | O | - | - | - | -      |
| GPIOs              | O | O | O | O | O | - | 3 pins |

Notes:

- (1) Y: Yes (Enable), O: Optional (Disabled by default, Enabled by software), -: Not available.
- (2) The pins that can wake up from the PD are PA0 (WKUP0), PC13 (WKUP1), PA2 (WKUP2), and NRST.

### 3.2.1 LPRUN Mode

In LPRUN mode, the system clock source can be configured as LSI or LSE by `RCC_LSCTRL.LPRUNCLKSEL`; PLL is off; all peripherals are configurable; the voltage regulator operates in normal mode. If the code runs in SRAM, `PWR_CTRL4.LPRUNFLH` can be configured to make the Flash enter deep standby mode. It cannot be configured if running on Flash. After entering LPRUN mode, the user cannot configure `RCC_CFG.SCLKSW[2:0]` to switch the system clock.

#### 3.2.1.1 Entering LPRUN mode

Before entering the LPRUN mode, user needs to turn on the LSI or LSE, and select the system clock source in the LPRUN mode through `RCC_LSCTRL.LPRUNCLKSEL`, and then configure `PWR_CTRL4.LPRUNEN = 1`, user can configure the

Flash to enter the deep standby mode as required. Note that a write key is required to enable write protection before accessing the PWR\_CTRL4 register.

### 3.2.1.2 Exiting LPRUN mode

Software sets PWR\_CTRL4.LPRUNEN = 0 to exit LPRUN mode, user can turn off LSI or LSE and switch system clock as needed. After exiting LPRUN mode, Flash automatically returns to normal mode.

## 3.2.2 SLEEP Mode

The CPU stops, all peripherals including peripherals around the Cortex<sup>®</sup>-M0 core (such as NVIC, SysTick, etc.) can run and wake up the CPU when an interrupt or event occurs.

### 3.2.2.1 Entering SLEEP mode

Enter SLEEP mode by executing WFI(Wait For Interrupt) or WFE(Wait For Event) instruction with SCB\_SCR.SLEEPDEEP = 0. Depending on the SCB\_SCR.SLEEPONEXIT, there are two options for SLEEP mode entry:

- SLEEP-NOW: If SCB\_SCR.SLEEPONEXIT = 0, the WFI or WFE instruction is executed immediately, and the system enters sleep mode immediately.
- SLEEP-ON-EXIT: If SCB\_SCR.SLEEPONEXIT = 1, the system immediately enters sleep mode when exiting from the lowest priority ISR.

### 3.2.2.2 Exiting SLEEP mode

If the WFI instruction is used to enter the SLEEP mode, any NVIC interrupts can wake up the device from the SLEEP mode.

If the WFE instruction is used to enter the SLEEP mode, MCU will exit the SLEEP mode immediately when the event occurs. Wake-up events can be generated in the following ways:

- Enable an interrupt in the peripheral control register instead of NVIC, and enable the SCB\_SCR.SEVONPEND. When MCU resumes from WFE, the peripheral interrupt pending bit and the peripheral NVIC interrupt channel suspend bit (in NVIC interrupt clear pending register) must be cleared.
- Configure an external or internal EXTI event mode. When the MCU wakes up, it is not necessary to clear the peripheral interrupt pending bit and the peripheral NVIC interrupt channel pending bit (in the NVIC interrupt clear pending register) because the pending bit corresponding to the event line is not set. This mode provides the shortest wake-up time because there is no time spent on interrupt entry or exit.

## 3.2.3 STOP Mode

STOP mode is based on the Cortex<sup>®</sup>-M0 deep sleep mode combined with peripheral clock gating. The voltage regulator operates in low power mode. The output voltage can be configured as 1.5V/1.2V. The HSE/HSI/PLL are disabled. The LSE/LSI can be configured to enable. All GPIO states, 8KB SRAM and all registers are retained. All IO, IWDG and PVD can be used to wake up the CPU. Or other peripherals (RTC/LPUART/LPTIM/COMP) can be configured to wake up. After waking up, the HSI is turned on, and the code starts from where it hangs. Flash is in deep sleep mode.

### 3.2.3.1 Entering STOP mode

To enter the STOP mode, user needs to set SCB\_SCR.SLEEPDEEP = 1 and PWR\_CTRL.PDSTP = 0.

If a Flash operation is in progress, entering STOP mode will be delayed until the memory access is completed.

If the access to the APB area is in progress, entering the STOP mode will be delayed until the APB access is completed.

In STOP mode, the following peripherals are available:

- Independent Watchdog (IWDG): Once enabled, it will keep counting until a reset is generated.
- RTC: It can be enable by `RCC_LSCTRL.RTCEN`.
- LPUART/LPTIM/COMP/PVD peripherals can wake up.
- Internal RC oscillator (LSI RC): It can be turned on by `RCC_LSCTRL.LSIEN`.
- External 32.768kHz crystal oscillator (LSE OSC): It can be turned on by `RCC_LSCTRL.LSEEN`.

ADC should be disabled when entering STOP mode to avoid unnecessary power consumption.

*Note: If the application needs to disable the external clock before entering the stop mode, it must first switch the system clock to HSI and then deassert `RCC_CTRL.HSEEN` bit. If `RCC_CTRL.HSEEN` bit remains asserted and the external clock (external oscillator) is removed when entering the stop mode, the clock safety system (CSS) function must be enabled to detect any external oscillator failure.*

### 3.2.3.2 Exiting STOP mode

When an interrupt or wake-up event wakes up STOP mode, the HSI RC oscillator is selected as the system clock, codes resumed from suspended location. Since the voltage regulator is in low-power mode in STOP mode, it consumes more startup time. In addition, users can configure `PWR_CTRL4.FLASHWKUP = 1` before entering STOP to shorten the wake-up time of Flash.

## 3.2.4 PD Mode

PD (Power Down) mode is based on Cortex<sup>®</sup>-M0 deep sleep mode, which can achieve lower power consumption. In this mode, the CPU, all peripherals, voltage regulator, HSE/HSI/PLL/LSE/LSI clock sources and all digital power supplies are turned off. Except for NRST/PA0/PC13/PA2, most IO ports output High-Z.

### 3.2.4.1 Entering PD mode

To enter the PD mode, user needs to set `SCB_SCR.SLEEPDEEP = 1` and `PWR_CTRL.PDSTP = 1`.

If a Flash operation is in progress, entering STOP mode will be delayed until the memory access is completed.

If the access to the APB area is in progress, entering the STOP mode will be delayed until the APB access is completed.

### 3.2.4.2 Exiting PD mode

The MCU exits PD mode when external reset (NRST pin), rising/falling edge of WKUP pin event occurs. And all registers will be reset after waking up.

After waking up from PD mode, code execution is same as power on (boot pin is detected, reset vector is read, etc.).

## 3.3 Debug Support

By default, if the application set the MCU to SLEEP, STOP or PD mode while using the debug features, the debug connection will be lost. This is due to the Cortex<sup>®</sup>-M0 core losing its clock.

However, by setting some configuration bits in the DBG\_CTRL register, it is possible to debug the software even when using in STOP and PD modes. If these register bits are configured, the voltage regulator and HSI will not be disabled or turned off.

### 3.3.1 Low Power Mode Debug Support

When debugging in low-power modes, it is essential to ensure that the FCLK of the core is turned on to provide the necessary clock for core debugging. User can debug the MCU in low power modes according to specific operations (Need to guarantee the output of FCLK in low power mode). For specific operations and features, please refer to the description of DBG\_CTRL.PD and DBG\_CTRL.STOP in Chapter 3.4.9.

### 3.3.2 Peripheral Debug Support

In addition to supporting debug in low power mode, it also supports some peripherals to stop operating in debug state (TIM1, TIM3, TIM6, TIM8, LPTIM, I<sup>2</sup>C1, I<sup>2</sup>C2, IWDG, WWDG). For specific operations and features, please refer to the description of the other bit fields of the DBG\_CTRL register in Chapter 3.4.9.

## 3.4 PWR Registers

### 3.4.1 PWR Register Overview

Table 3-3 PWR Register Overview

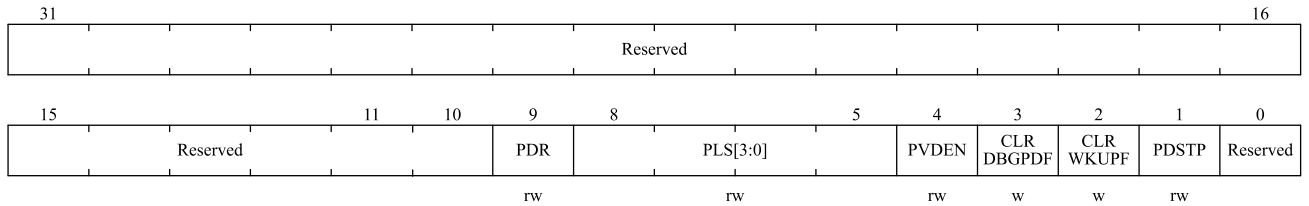
| Offset | Register    | 31       | 30 | 29 | 28 | 27 | 26 | 25 | 24 | 23 | 22 | 21        | 20       | 19      | 18      | 17       | 16       | 15            | 14       | 13       | 12     | 11      | 10 | 9   | 8        | 7 | 6 | 5     | 4        | 3        | 2     | 1        | 0 |
|--------|-------------|----------|----|----|----|----|----|----|----|----|----|-----------|----------|---------|---------|----------|----------|---------------|----------|----------|--------|---------|----|-----|----------|---|---|-------|----------|----------|-------|----------|---|
| 0x00   | PWR_CTRL    | Reserved |    |    |    |    |    |    |    |    |    |           |          |         |         |          |          |               |          |          |        |         |    | PDR | PLS[3:0] |   |   | PVDEN | CLRBGPDF | CLRWKUPF | PDSTP | Reserved |   |
|        | Reset value |          |    |    |    |    |    |    |    |    |    |           |          |         |         |          |          |               |          |          |        |         |    | 1   | 0        | 0 | 0 | 0     | 0        | 0        | 0     | 0        |   |
| 0x04   | PWR_CTRLSTS | Reserved |    |    |    |    |    |    |    |    |    | WKUPPOL   | WKUP2EN  | WKUPIEN | WKUPOEN | Reserved |          |               |          | PVDO     | DBGPDF | WKUPF   |    |     |          |   |   |       |          |          |       |          |   |
|        | Reset value |          |    |    |    |    |    |    |    |    |    | 1         | 0        | 0       | 0       |          |          |               |          | 0        | 0      | 0       |    |     |          |   |   |       |          |          |       |          |   |
| 0x08   | PWR_CTRL2   | Reserved |    |    |    |    |    |    |    |    |    | IWDGRSTEN | Reserved |         |         |          |          |               |          |          |        |         |    |     |          |   |   |       |          |          |       |          |   |
|        | Reset value |          |    |    |    |    |    |    |    |    |    | 1         |          |         |         |          |          |               |          |          |        |         |    |     |          |   |   |       |          |          |       |          |   |
| 0x14   | PWR_CTRL3   | Reserved |    |    |    |    |    |    |    |    |    |           |          |         |         | LSIEN    | Reserved |               |          |          |        |         |    |     |          |   |   |       |          |          |       |          |   |
|        | Reset value |          |    |    |    |    |    |    |    |    |    |           |          |         |         | 0        |          |               |          |          |        |         |    |     |          |   |   |       |          |          |       |          |   |
| 0x20   | PWR_CTRL4   | Reserved |    |    |    |    |    |    |    |    |    |           |          |         |         | LPRUNSTS | LPRUNFLH | LPRUNEN       | Reserved |          | STBFLH | FLHWKUP |    |     |          |   |   |       |          |          |       |          |   |
|        | Reset value |          |    |    |    |    |    |    |    |    |    |           |          |         |         | 0        | 1        | 0             |          |          | 0      | 0       |    |     |          |   |   |       |          |          |       |          |   |
| 0x24   | PWR_CTRL5   | Reserved |    |    |    |    |    |    |    |    |    |           |          |         |         |          |          | SLPMRSEL[1:0] |          | Reserved |        |         |    |     |          |   |   |       |          |          |       |          |   |
|        | Reset value |          |    |    |    |    |    |    |    |    |    |           |          |         |         |          |          | 0             | 1        |          |        |         |    |     |          |   |   |       |          |          |       |          |   |
| 0x28   | PWR_CTRL6   | Reserved |    |    |    |    |    |    |    |    |    |           |          |         |         |          |          | SLPMREN[1:0]  |          | Reserved |        |         |    |     |          |   |   |       |          |          |       |          |   |
|        | Reset value |          |    |    |    |    |    |    |    |    |    |           |          |         |         |          |          | 0             | 0        |          |        |         |    |     |          |   |   |       |          |          |       |          |   |

| Offset | Register    | 31       | 30 | 29 | 28 | 27 | 26 | 25 | 24 | 23 | 22 | 21 | 20 | 19      | 18       | 17      | 16        | 15         | 14         | 13       | 12      | 11       | 10       | 9        | 8        | 7        | 6 | 5 | 4 | 3  | 2    | 1        | 0 |
|--------|-------------|----------|----|----|----|----|----|----|----|----|----|----|----|---------|----------|---------|-----------|------------|------------|----------|---------|----------|----------|----------|----------|----------|---|---|---|----|------|----------|---|
| 0x30   | DBG_CTRL    | Reserved |    |    |    |    |    |    |    |    |    |    |    | TIM8STP | Reserved | TIM6STP | LPTIM5STP | I2C2TIMOUT | I2C1TIMOUT | Reserved | TIM3STP | Reserved | TIM1ISTP | WWDG5STP | IWDG5STP | Reserved |   |   |   | PD | STOP | Reserved |   |
|        | Reset value |          |    |    |    |    |    |    |    |    |    |    |    | 0       |          | 0       | 0         | 0          | 0          |          | 0       |          | 0        | 0        | 0        |          |   |   |   | 0  | 0    |          |   |

### 3.4.2 Power Control Register (PWR\_CTRL)

Address offset: 0x00

Reset value: 0x0000 0200



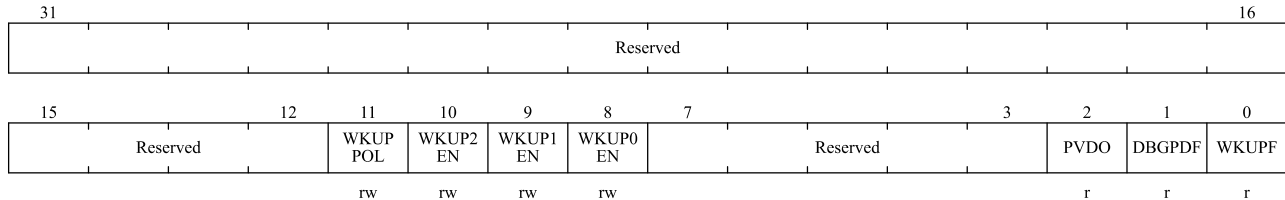
| Bit Field    | Name     | Description   |              |         |      |      |      |      |      |      |      |      |      |      |      |      |      |      |      |      |      |      |      |      |      |      |      |      |      |      |      |      |      |      |      |      |
|--------------|----------|---|--------------|---------|------|------|------|------|------|------|------|------|------|------|------|------|------|------|------|------|------|------|------|------|------|------|------|------|------|------|------|------|------|------|------|------|
| 31:10        | Reserved | Reserved, the reset value must be maintained.   |              |         |      |      |      |      |      |      |      |      |      |      |      |      |      |      |      |      |      |      |      |      |      |      |      |      |      |      |      |      |      |      |      |      |
| 9            | PDR      | Tune V <sub>DDD</sub> PDR trigger level during STOP mode.<br>0: V <sub>DDD</sub> PDR trigger at 1.0V<br>1: V <sub>DDD</sub> PDR trigger at 1.2V<br>Only V <sub>DDD</sub> POR/PDR can reset this bit.  |              |         |      |      |      |      |      |      |      |      |      |      |      |      |      |      |      |      |      |      |      |      |      |      |      |      |      |      |      |      |      |      |      |      |
| 8:5          | PLS[3:0] | PVD level selection.<br>PVD threshold is controlled below: <table border="1" style="margin-left: 20px;"> <thead> <tr> <th>PWR_CTRL.PLS</th> <th>Voltage</th> </tr> </thead> <tbody> <tr><td>0000</td><td>1.8v</td></tr> <tr><td>0001</td><td>2.0v</td></tr> <tr><td>0010</td><td>2.2v</td></tr> <tr><td>0011</td><td>2.4v</td></tr> <tr><td>0100</td><td>2.6v</td></tr> <tr><td>0101</td><td>2.8v</td></tr> <tr><td>0110</td><td>3.0v</td></tr> <tr><td>0111</td><td>3.2v</td></tr> <tr><td>1000</td><td>3.4v</td></tr> <tr><td>1001</td><td>3.6v</td></tr> <tr><td>1010</td><td>3.8v</td></tr> <tr><td>1011</td><td>4.0v</td></tr> <tr><td>1100</td><td>4.2v</td></tr> <tr><td>1101</td><td>4.6v</td></tr> <tr><td>1110</td><td>4.8v</td></tr> <tr><td>1111</td><td>5.0v</td></tr> </tbody> </table> | PWR_CTRL.PLS | Voltage | 0000 | 1.8v | 0001 | 2.0v | 0010 | 2.2v | 0011 | 2.4v | 0100 | 2.6v | 0101 | 2.8v | 0110 | 3.0v | 0111 | 3.2v | 1000 | 3.4v | 1001 | 3.6v | 1010 | 3.8v | 1011 | 4.0v | 1100 | 4.2v | 1101 | 4.6v | 1110 | 4.8v | 1111 | 5.0v |
| PWR_CTRL.PLS | Voltage  |   |              |         |      |      |      |      |      |      |      |      |      |      |      |      |      |      |      |      |      |      |      |      |      |      |      |      |      |      |      |      |      |      |      |      |
| 0000         | 1.8v     |   |              |         |      |      |      |      |      |      |      |      |      |      |      |      |      |      |      |      |      |      |      |      |      |      |      |      |      |      |      |      |      |      |      |      |
| 0001         | 2.0v     |   |              |         |      |      |      |      |      |      |      |      |      |      |      |      |      |      |      |      |      |      |      |      |      |      |      |      |      |      |      |      |      |      |      |      |
| 0010         | 2.2v     |   |              |         |      |      |      |      |      |      |      |      |      |      |      |      |      |      |      |      |      |      |      |      |      |      |      |      |      |      |      |      |      |      |      |      |
| 0011         | 2.4v     |   |              |         |      |      |      |      |      |      |      |      |      |      |      |      |      |      |      |      |      |      |      |      |      |      |      |      |      |      |      |      |      |      |      |      |
| 0100         | 2.6v     |   |              |         |      |      |      |      |      |      |      |      |      |      |      |      |      |      |      |      |      |      |      |      |      |      |      |      |      |      |      |      |      |      |      |      |
| 0101         | 2.8v     |   |              |         |      |      |      |      |      |      |      |      |      |      |      |      |      |      |      |      |      |      |      |      |      |      |      |      |      |      |      |      |      |      |      |      |
| 0110         | 3.0v     |   |              |         |      |      |      |      |      |      |      |      |      |      |      |      |      |      |      |      |      |      |      |      |      |      |      |      |      |      |      |      |      |      |      |      |
| 0111         | 3.2v     |   |              |         |      |      |      |      |      |      |      |      |      |      |      |      |      |      |      |      |      |      |      |      |      |      |      |      |      |      |      |      |      |      |      |      |
| 1000         | 3.4v     |   |              |         |      |      |      |      |      |      |      |      |      |      |      |      |      |      |      |      |      |      |      |      |      |      |      |      |      |      |      |      |      |      |      |      |
| 1001         | 3.6v     |   |              |         |      |      |      |      |      |      |      |      |      |      |      |      |      |      |      |      |      |      |      |      |      |      |      |      |      |      |      |      |      |      |      |      |
| 1010         | 3.8v     |   |              |         |      |      |      |      |      |      |      |      |      |      |      |      |      |      |      |      |      |      |      |      |      |      |      |      |      |      |      |      |      |      |      |      |
| 1011         | 4.0v     |   |              |         |      |      |      |      |      |      |      |      |      |      |      |      |      |      |      |      |      |      |      |      |      |      |      |      |      |      |      |      |      |      |      |      |
| 1100         | 4.2v     |   |              |         |      |      |      |      |      |      |      |      |      |      |      |      |      |      |      |      |      |      |      |      |      |      |      |      |      |      |      |      |      |      |      |      |
| 1101         | 4.6v     |   |              |         |      |      |      |      |      |      |      |      |      |      |      |      |      |      |      |      |      |      |      |      |      |      |      |      |      |      |      |      |      |      |      |      |
| 1110         | 4.8v     |   |              |         |      |      |      |      |      |      |      |      |      |      |      |      |      |      |      |      |      |      |      |      |      |      |      |      |      |      |      |      |      |      |      |      |
| 1111         | 5.0v     |   |              |         |      |      |      |      |      |      |      |      |      |      |      |      |      |      |      |      |      |      |      |      |      |      |      |      |      |      |      |      |      |      |      |      |

| Bit Field | Name      | Description   |
|-----------|-----------|---|
| 4         | PVDEN     | Enable of Power voltage detector. Software control.<br>0: PVD disabled<br>1: PVD enabled  |
| 3         | CLRDBGPDF | Clear DBG_PD mode flag.<br>Always read as 0.<br>0: No effect.<br>1: Clear PWR_CTRLSTS.DBGPDF bit flag after 2 System clock cycles. (write)  |
| 2         | CLRWKUPF  | Clear wake up flag.<br>Always read as 0.<br>0: No effect.<br>1: Clear PWR_CTRLSTS.WKUPF bit flag after 2 System clock cycles. (write)   |
| 1         | PDSTP     | Enter STOP/PD mode selection<br>Software will set and clear this bit.<br>0: Enter STOP mode when CPU enters deep-sleep mode.<br>1: Enter PD mode when CPU enters deep-sleep mode. |
| 0         | Reserved  | Reserved, the reset value must be maintained.   |

### 3.4.3 Power Control Status Register (PWR\_CTRLSTS)

Address offset: 0x04

Reset value: 0x0000 0800



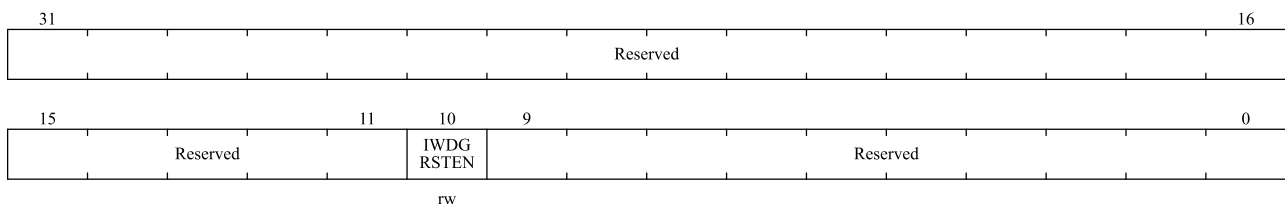
| Bit Field | Name     | Description  |
|-----------|----------|--|
| 31:12     | Reserved | Reserved, the reset value must be maintained.  |
| 11        | WKUPPOL  | Wakeup polarity for PA0/PA2/PC13. To wakeup PD mode by using rising edge or falling edge. Make sure disable wakeup enable before changing polarity value.<br>0: Falling edge<br>1: Rising edge   |
| 10        | WKUP2EN  | Enable PA2_WKUP pin<br>Software can set and clear this bit.<br>0: WKUP pin is used for general purpose I/O. An event on the WKUP pin does not wakeup the device from PD mode.<br>1: WKUP pin is used for wakeup from PD mode.<br><i>Note: This bit is reset by V<sub>DD</sub>POR/PDR Reset only.</i> |

| Bit Field | Name     | Description   |
|-----------|----------|---|
| 9         | WKUP1EN  | Enable PC13_WKUP pin<br>Software can set and clear this bit.<br>0: WKUP pin is used for general purpose I/O. An event on the WKUP pin does not wakeup the device from PD mode.<br>1: WKUP pin is used for wakeup from PD mode.<br><i>Note: This bit is reset by V<sub>DDD</sub> POR/PDR Reset only.</i>         |
| 8         | WKUP0EN  | Enable PA0_WKUP pin<br>Software can set and clear this bit.<br>0: WKUP pin is used for general purpose I/O. An event on the WKUP pin does not wakeup the device from PD mode.<br>1: WKUP pin is used for wakeup from PD mode.<br><i>Note: This bit is reset by V<sub>DDD</sub> POR/PDR Reset only.</i>          |
| 7:3       | Reserved | Reserved, the reset value must be maintained.   |
| 2         | PVDO     | PVD output.<br>Hardware will set and clear this bit. It is valid only if PWR_CTRL.PVDEN = 1.<br>0: V <sub>DD</sub> /V <sub>DDA</sub> is higher than the PVD threshold selected with PWR_CTRL.PLS[3:0]<br>1: V <sub>DD</sub> /V <sub>DDA</sub> is lower than the PVD threshold selected with PWR_CTRL.PLS[3:0]   |
| 1         | DBGPDF   | DBGPD mode status bit.<br>When entering DBGPD mode, hardware sets this bit to '1'.<br>Hardware clears this bit when software sets PWR_CTRL.CLRDBGPDF = 1.<br>Only V <sub>DDD</sub> POR/PDR can reset this bit.<br>0: Chip never entered DBGPD mode<br>1: Chip has entered DBGPD mode                            |
| 0         | WKUPF    | DBGPD mode wake-up status bit.<br>This bit is set by hardware after WKUP pin wakes up DBGPD mode.<br>Hardware clears this bit when software sets PWR_CTRL.CLRWKUPF = 1.<br>Only V <sub>DDD</sub> POR/PDR can reset this bit.<br>0: No wakeup event occurred<br>1: A wakeup event was received from the WKUP pin |

### 3.4.4 Power Control Register 2 (PWR\_CTRL2)

Address offset: 0x08

Reset value: 0x0000 0400



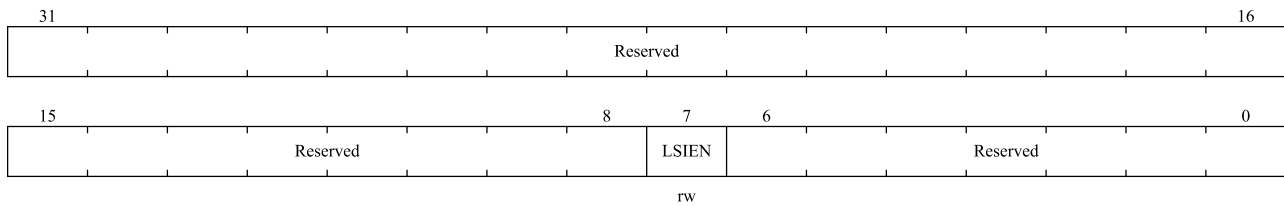


| Bit Field | Name      | Description   |
|-----------|-----------|---|
| 31:11     | Reserved  | Reserved, the reset value must be maintained.   |
| 10        | IWDGRSTEN | Independent watchdog reset enable.<br>0: Independent watchdog cannot generate reset to RCC.<br>1: Independent watchdog can generate reset to RCC. |
| 9:0       | Reserved  | Reserved, the reset value must be maintained.   |

### 3.4.5 Power Control Register 3 (PWR\_CTRL3)

Address offset: 0x14

Reset value: 0x0000 037F



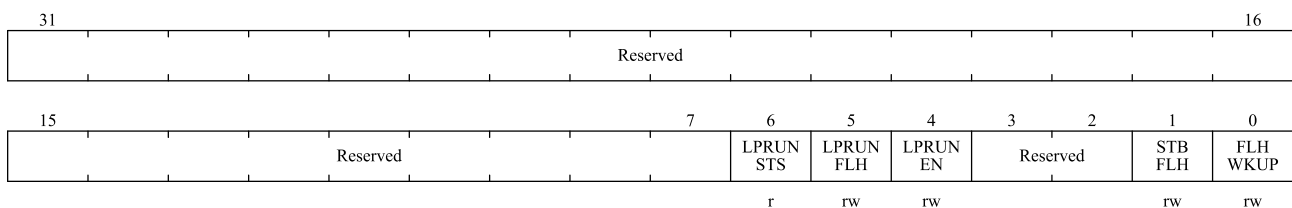
| Bit Field | Name     | Description  |
|-----------|----------|--|
| 31:8      | Reserved | Reserved, the reset value must be maintained.  |
| 7         | LSIEN    | Control PWR to enable LSI.<br>0: PWR continues requesting LSI clock after system enter STOP mode<br>1: PWR stops requesting LSI clock after system enter STOP mode |
| 6:0       | Reserved | Reserved, the reset value must be maintained.  |

### 3.4.6 Power Control Register 4 (PWR\_CTRL4)

Address offset: 0x20

Reset value: 0x0000 0020

This register has write protection. Before each software write operation to this register, it must first write the key 0x0175\_3603 to this register to release the write protection.



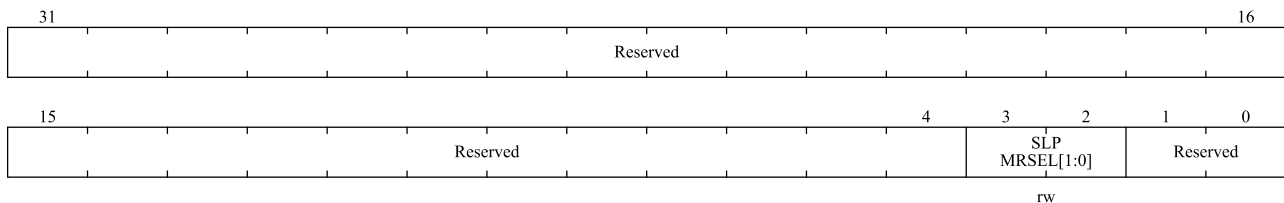
| Bit Field | Name     | Description  |
|-----------|----------|--|
| 31:7      | Reserved | Reserved, the reset value must be maintained.  |
| 6         | LPRUNSTS | LPRUN mode entry status.<br>This bit is set and cleared by hardware.<br>0: System exited LPRUN mode<br>1: System in LPRUN mode |

| Bit Field | Name     | Description   |
|-----------|----------|---|
| 5         | LPRUNFLH | Flash low-power control for LPRUN mode.<br>0: Put Flash to deep standby after chip enters LPRUN mode<br>1: Keep Flash to normal operating state after chip enters LPRUN mode  |
| 4         | LPRUNEN  | LPRUN mode enable<br>This bit is set and cleared by software and can also be cleared by hardware in STOP and PD modes.<br>0: System exits LPRUN mode<br>1: System enters LPRUN mode   |
| 3:2       | Reserved | Reserved, the reset value must be maintained.   |
| 1         | STBFLH   | Flash deep standby mode enable (RUN, can be configured in SLEEP mode)<br>This bit is set and cleared by software and can also be cleared by hardware in STOP and PD modes.<br>0: Flash back to normal mode<br>1: Flash enters deep standby mode |
| 0         | FLHWKUP  | Flash fast wakeup enable<br>0: Disable fast wake-up when system exits from STOP (wake-up time ~10us)<br>1: Enable fast wake-up when system exits from STOP (wake-up time ~5us)  |

### 3.4.7 Power Control Register 5 (PWR\_CTRL5)

Address offset: 0x24

Reset value: 0x0000 0007

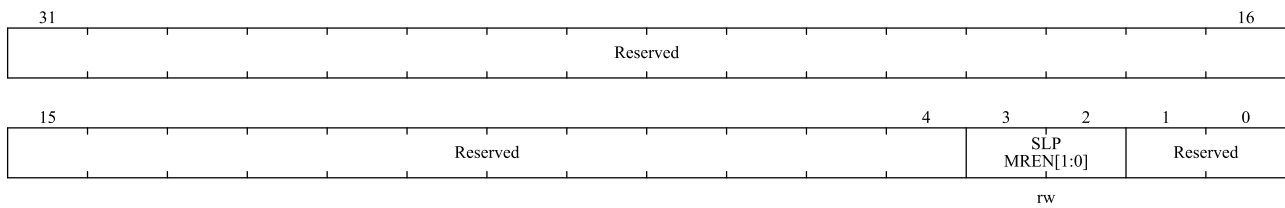


| Bit field | Name     | Description   |
|-----------|----------|---|
| 31:4      | Reserved | Reserved, the reset value must be maintained.   |
| 3:2       | SLPMRSEL | V <sub>DDD</sub> output voltage selection after system enters STOP mode.<br>Before configuring these bits, software must first configure PWR_CTRL6.SLPMREN = '11'.<br>00: Reserved<br>01: V <sub>DDD</sub> output voltage is 1.5V<br>10: Reserved<br>11: V <sub>DDD</sub> output voltage is 1.2V<br>Only V <sub>DDD</sub> POR/PDR can reset this bit. |
| 1:0       | Reserved | Reserved, the reset value must be maintained.   |

### 3.4.8 Power Control Register 6 (PWR\_CTRL6)

Address offset: 0x28

Reset value: 0x0000 0000



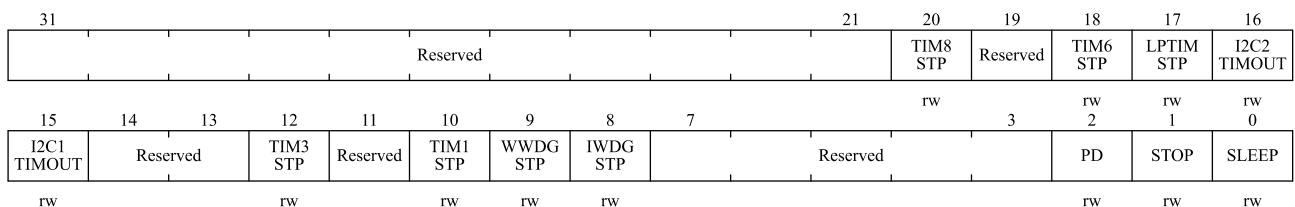
| Bit Field | Name     | Description   |
|-----------|----------|---|
| 31:4      | Reserved | Reserved, the reset value must be maintained.   |
| 3:2       | SLPMREN  | V <sub>DDD</sub> output voltage selection enable<br>00: After entering STOP mode, V <sub>DDD</sub> output voltage remains at 1.5V<br>01: Reserved<br>10: Reserved<br>11: After entering STOP mode, V <sub>DDD</sub> output voltage is controlled by PWR_CTRL5.SLPMRSEL<br>Only V <sub>DDD</sub> POR/PDR can reset this bit. |
| 1:0       | Reserved | Reserved, the reset value must be maintained.   |

### 3.4.9 Debug Control Register (Dbg\_CTRL)

Address offset: 0x30

Reset value: 0x0000 0000

Only V<sub>DDD</sub> POR/PDR can reset this register. Only after connecting to the Debugger, software can write access to this register.



| Bit Field | Name     | Description   |
|-----------|----------|---|
| 31:21     | Reserved | Reserved, the reset value must be maintained.   |
| 20        | TIM8STP  | TIM8 stops operating when core enters debug state.<br>This bit is set or cleared by software.<br>0: The counter of TIM8 operates normally<br>1: The counter of TIM8 stops operating |
| 19        | Reserved | Reserved, the reset value must be maintained.   |
| 18        | TIM6STP  | TIM6 stops operating when core enters debug state.<br>This bit is set or cleared by software.<br>0: The counter of TIM6 operates normally<br>1: The counter of TIM6 stops operating |
| 17        | LPTIMSTP | LPTIM stops operating when core enters debug state.   |

| Bit Field | Name        | Description   |
|-----------|-------------|---|
|           |             | This bit is set or cleared by software.<br>0: The counter of LPTIM operates normally<br>1: The counter of LPTIM stops operating   |
| 16        | I2C2TIMEOUT | I <sup>2</sup> C2 stops SMBUS timeout mode when core is stopped.<br>This bit is set or cleared by software.<br>0: Same as normal mode operation<br>1: Frozen the timeout control of SMBUS   |
| 15        | I2C1TIMEOUT | I <sup>2</sup> C1 stops SMBUS timeout mode when core is stopped.<br>This bit is set or cleared by software.<br>0: Same as normal mode operation<br>1: Frozen the timeout control of SMBUS   |
| 14:13     | Reserved    | Reserved, the reset value must be maintained.   |
| 12        | TIM3STP     | TIM3 stops operating when core enters debug state.<br>This bit is set or cleared by software.<br>0: The counter of TIM3 operates normally<br>1: The counter of TIM3 stops operating   |
| 11        | Reserved    | Reserved, the reset value must be maintained.   |
| 10        | TIM1STP     | TIM1 stops operating when core enters debug state.<br>This bit is set or cleared by software.<br>0: The counter of TIM1 operates normally<br>1: The counter of TIM1 stops operating   |
| 9         | WWDGSTP     | WWDG stops operating when core enters debug state.<br>This bit is set or cleared by software.<br>0: The counter of WWDG operates normally<br>1: The counter of WWDG stops operating   |
| 8         | IWDGSTP     | IWDG stops operating when core enters debug state.<br>This bit is set or cleared by software.<br>0: The counter of IWDG operates normally<br>1: The counter of IWDG stops operating   |
| 7:3       | Reserved    | Reserved, the reset value must be maintained.   |
| 2         | PD          | Debug PD mode control.<br>This bit is set or cleared by software.<br>0: (FCLK off, HCLK off) system enters PD mode, digital circuit part is unpowered. From a software point of view, exiting PD mode is the same as a power-on reset.<br>1: (FCLK on, HCLK on) system enters DBGPD mode, digital circuit part is powered, and FCLK clock is provided by the internal RC oscillator. In addition, the microcontroller exits DBGPD mode by generating a system reset, which is the same as a system reset. |

| Bit Field | Name  | Description  |
|-----------|-------|--|
| 1         | STOP  | <p>Debug STOP mode control.</p> <p>This bit is set or cleared by software.</p> <p>0: (FCLK off, HCLK off) system enters STOP mode, clock controller disables all clocks (including HCLK and FCLK). When exiting STOP mode, the configuration of the clock is the same as after reset (Microcontroller is clocked by the 8MHz internal RC oscillator (HSI)). Therefore, software must reconfigure the clock control system to enable PLL, external oscillator, etc.</p> <p>1: (FCLK on, HCLK on) system enters DBGSTOP mode, FCLK clock is provided by the internal RC oscillator. When exiting DBGSTOP mode, the software must reconfigure the clock control system to enable PLL, external oscillator, etc. (same operation as when configuring this bit to 0).</p> |
| 0         | SLEEP | <p>Debug SLEEP mode.</p> <p>Set or cleared by software.</p> <p>0: (FCLK on, HCLK off) In SLEEP mode, FCLK is provided by the previously configured system clock, and HCLK is off. Since SLEEP mode does not reset the configured clock system, software does not need to reconfigure the clock system when exiting from SLEEP mode.</p> <p>1: (FCLK on, HCLK on) In DBGSLEEP mode, both FCLK and HCLK clocks are provided by the previously configured system clock.</p>   |

## 4 Reset and Clock Control (RCC)

### 4.1 Reset Control Unit

N32G031 supports the following two types of reset:

- Power Reset
- System Reset

#### 4.1.1 Power Reset

A power reset occurs in the following circumstances:

- Power-on/ Power-down reset (POR/PDR reset).
- When exiting PD mode.

A power reset will set all registers to their reset values (see **Figure 3-1**).

The reset source will finally act on the NRST pin and remain low during reset. The reset entry vector is fixed at address 0x0000\_0004. For more details, see **Table 6-1** Vector table.

#### 4.1.2 System Reset

Except for the following registers, a system reset will reset all registers to their reset states:

- RCC\_CTRL.HSEBP
- RCC\_CTRLSTS
- RCC\_EMCTRL
- RCC\_LSCTRL.LSEBP
- PWR\_CTRL.STPPLSEN
- PWR\_CTRL.PDR
- PWR\_CTRL5
- PWR\_CTRL6
- DBG\_CTRL

A system reset is generated when one of the following events occurs:

- A low level on the NRST pin (external reset)
- Window watchdog event(WWDG reset)
- Independent watchdog event(IWDG reset)
- Software reset (SW reset)
- Low power management reset

- MMU protection reset
- RAM parity error reset
- EMC reset

The reset source can be identified by checking the reset flags in the Control/Status register (RCC\_CTRLSTS).

**4.1.2.1 Software reset**

A software reset can be generated by setting the SYSRESETREQ bit in Cortex<sup>®</sup>-M0 Application Interrupt and Reset Control Register. Refer to Cortex<sup>®</sup>-M0 technical reference manual for further information.

**4.1.2.2 Low-power management reset**

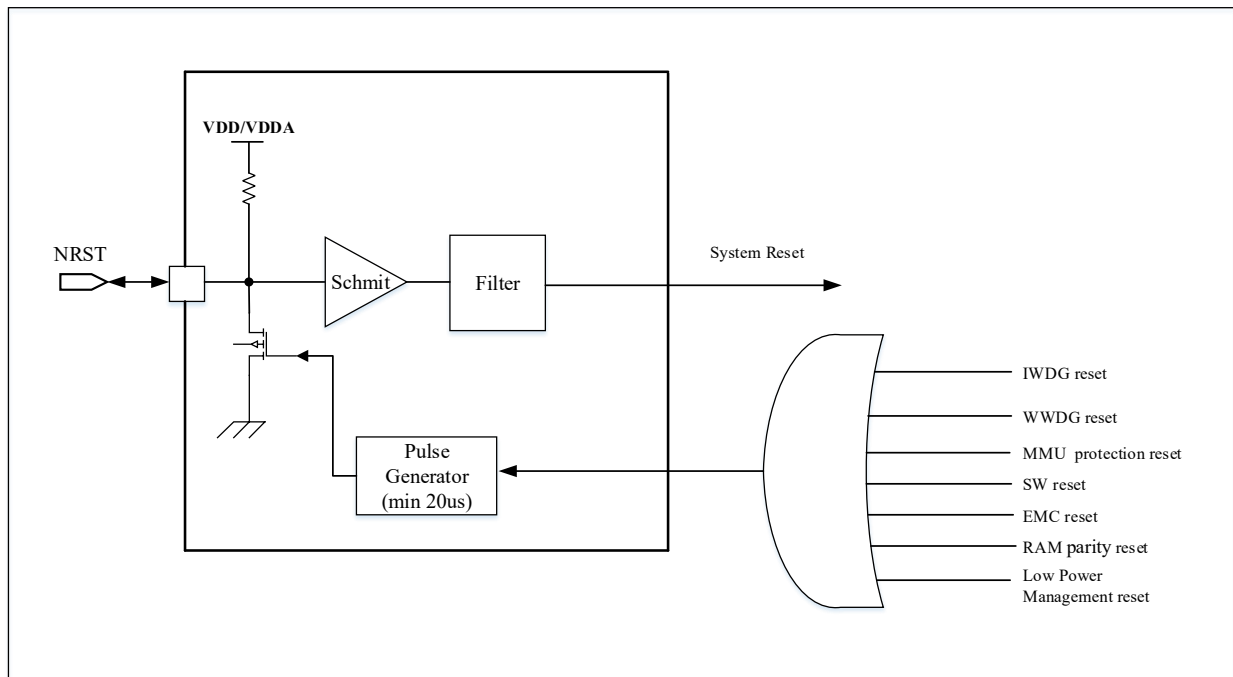
Low-power management reset can be generated by using the following methods:

- Generate low-power management reset when entering PD mode: This reset is enabled by resetting the nRST\_PD bit in User Option Bytes. In this case, whenever a PD mode entry sequence is successfully executed, the system is reset instead of entering PD mode.
- Generate low-power management reset when entering STOP modes: This reset is enabled by resetting the nRST\_STOP bit in User Option Bytes. In this case, whenever a STOP mode entry sequence is successfully executed, the system is reset instead of entering STOP modes.

The system reset signal provided to the chip is output on the NRST pin. The pulse generator guarantees a minimum reset pulse duration of 20µs for each reset source (external or internal). For external reset, the reset pulse is generated while the NRST pin is asserted low.

The Figure below shows the system reset generation circuit.

**Figure 4-1 System Reset Generation**



## 4.2 Clock Control Unit

Five different clock sources can be used to drive the system clock (SYSCLK):

- HSI oscillator clock
- HSE oscillator clock
- PLL clock
- LSI oscillator clock
- LSE oscillator clock

The devices have the following two secondary clock sources:

- LSI: 30 kHz low-speed internal RC can be used to drive independent watchdog (IWDG) and drive RTC, LPTIMER and LPUART through program selection. It is used for Auto-wakeup from STOP mode.
- LSE: 32.768 kHz low-speed external crystal can also be used to drive RTC, LPTIMER and LPUART through program selection.

Each clock source can be turned on or off independently to optimize power consumption when it is not used.

The frequency of the AHB, APB (APB1 and APB2) domains can be configured by the user through multiple prescalers. The maximum allowable frequency of the AHB domain, APB1 domain and APB2 domain is 48MHz.

All peripheral clocks are derived from the system clock (SYSCLK) except in the following cases:

- ADC clock is the AHB/PLL divided clock.
- LPUART operating clock can come from one of the following six sources, which can be configured by software:
  - HSI clock
  - HSE Clock
  - LSI clock
  - LSE clock
  - SYSCLK system clock
  - APB1 clock (PCLK)
- LPTIMER operating clock can come from one of the following six sources, which can be configured by software:
  - HSI clock
  - HSE Clock
  - LSI clock
  - LSE clock
  - COMP\_OUT
  - APB1 clock (PCLK)



- RTCCLK clock source can be provided by HSE/128, LSE or LSI clock.
  - LSE clock
  - LSI clock
  - HSE clock divided by 128
- IWDG clock source is LSI oscillator.
- Flash memory programming interface clock is always the HSI clock

RCC provides Cortex system timer (SysTick) external clock with the AHB clock (HCLK) divided by 8. Either the above clock or the Cortex clock (HCLK) can be selected to drive the SysTick by programming the SysTick control and status registers.

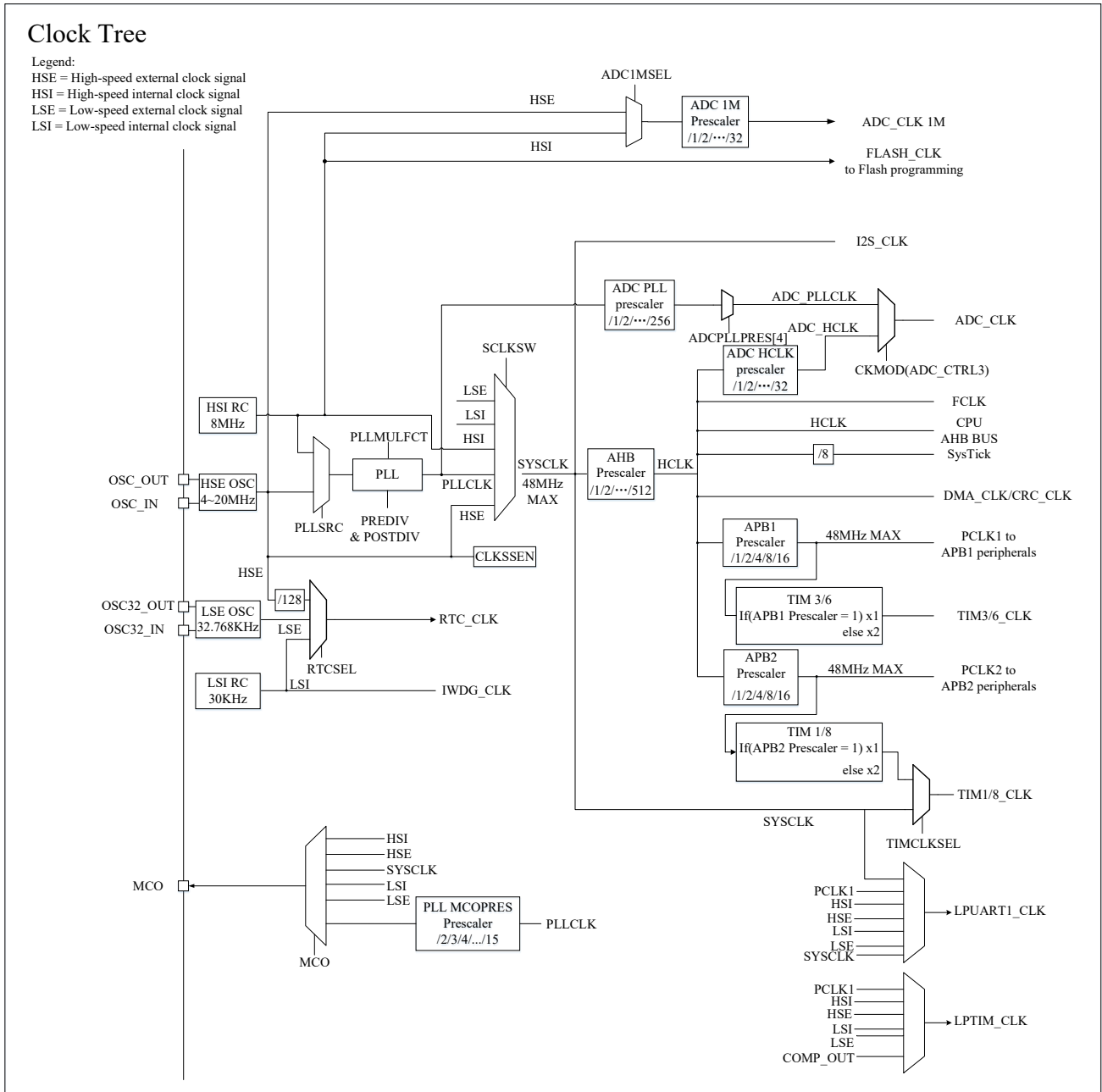
The timer clock frequency is automatically set by hardware in the following 2 cases:

- If the APB prescaler is 1, the timer clock frequency is the same as the frequency of the APB bus it is connected to.
- If the APB prescaler is not 1, the timer clock frequency is twice the frequency of the APB bus it is connected to.

FCLK is the free running clock of the Cortex<sup>®</sup>-M0. Refer to ARM's Cortex<sup>®</sup>-M0 Technical Reference Manual for details.

### 4.2.1 Clock Tree Diagram

Figure 4-2 Clock Tree



1. The maximum frequency available for the system clock is 48MHz.
2. For more details about the internal and external clock source characteristics, please refer to the "Electrical Characteristics" section in the product datasheet.

### 4.2.2 HSE Clock

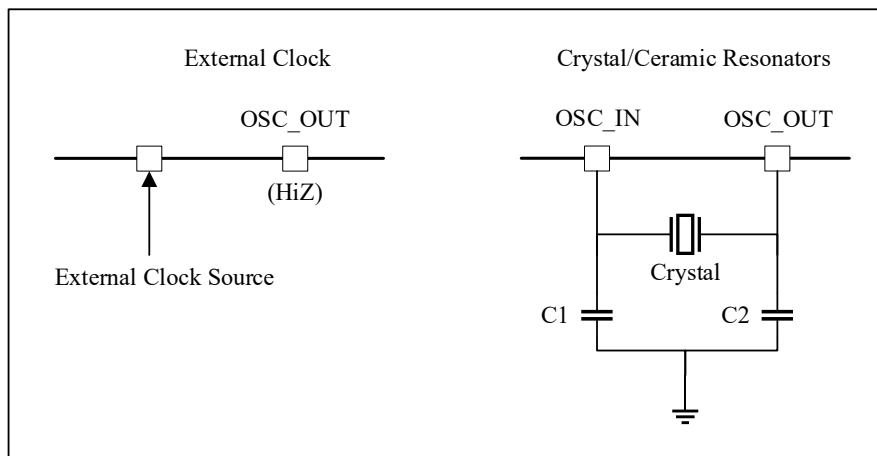
The high-speed external clock signal (HSE) can be generated from the following two clock sources:

- HSE external crystal/ceramic resonator
- HSE user external clock(Input through the PF0 pin)

In HSE bypass mode or crystal mode, RCC\_CTRL.HSEEN needs to be set to 1. If RCC\_CTRL.HSEEN=0, HSE will be turned off.

To reduce distortion of the clock output and shorten the start-up settling time, the crystal/ceramic resonator and load capacitor must be placed as close as possible to the oscillator pins of the chip. The loading capacitance value must be adjusted according to the chosen oscillator.

**Figure 4-3 HSE Clock Source**



**4.2.2.1 External clock source (HSE bypass mode)**

In this mode, an external clock source must be provided. Its frequency can be up to 20MHz. Users can select this mode by setting the RCC\_CTRL.HSEBP and RCC\_CTRL.HSEEN bits. When PF0 is used as an external clock signal (square wave, sine wave or triangle wave with 50% duty cycle), it must be connected to the OSC\_IN pin, and the OSC\_OUT pin must be floating (Hi-Z). See Figure 4-3.

**4.2.2.2 External crystal/ceramic resonator (HSE crystal mode)**

The 4 to 20MHz external oscillator has the advantage of producing a more accurate main clock for the system. The associated hardware configuration is shown in Figure 4-3. For more details, please refer to the electrical characteristics section of the datasheet.

The RCC\_CTRL.HSERDF bit indicates whether the high-speed external oscillator is stable or not. At startup, the clock is not released until this bit is set by hardware. An interrupt can be generated if enabled in the Clock Interrupt Register (RCC\_CLKINT).

HSE clock can be switched on and off by setting the RCC\_CTRL.HSEEN bit.

If the user needs to change the configuration of RCC\_CTRL.HSEBP during operation, it should be configured before enabling RCC\_CTRL.HSEEN.

**4.2.3 HSI Clock**

The HSI (High Speed Internal) clock signal is generated by an internal 8MHz RC oscillator and can be directly used as the system clock or PLL input. The HSI RC oscillator can provide a clock source without any external devices. It also has a

shorter startup time than the HSE crystal oscillator. However, its frequency is less accurate even with calibration.

The manufacturing process determines that the RC oscillator frequency of different chips will be different. Therefore, the HSI clock frequency of each chip has been calibrated to 1% (25°C) before leaving the factory.

If the user application is subject to voltage or temperature variations, this may affect the accuracy of the RC oscillator. The HSI frequency can be trimmed by using the `RCC_CTRL.HSITRIM[4:0]` bits.

The `RCC_CTRL.HSIRDF` bit flag indicates if the HSI RC oscillator is stable. At startup, the HSI RC output clock is not released until this bit is set by hardware. HSI clock can be switched on and off using the `RCC_CTRL.HSIEN` bit.

If the HSE crystal oscillator fails, the HSI clock can be used as a backup source. Refer to section 4.2.8 Clock security system (CLKSS).

### 4.2.4 PLL Clock

The internal PLL can be used to multiply the HSI or the HSE clock frequency. Refer to Figure 4-4. The settings of the PLL (selecting HSI or HSE as the input clock of the PLL, selecting the multiplier, selecting the prescaler and the postscaler) must be completed before it is activated. Once the PLL is activated, these parameters cannot be changed. The PLL can be configured using control bits in `RCC_CTRL` and `RCC_CFG` registers.

When switching the input clock source of the PLL, the original clock source must be turned off after configuring the new clock source (through the clock configuration register bit `RCC_CFG.PLLSRC`).

If the PLL interrupt is enabled in the clock interrupt register, an interrupt request can be generated when the PLL is ready.

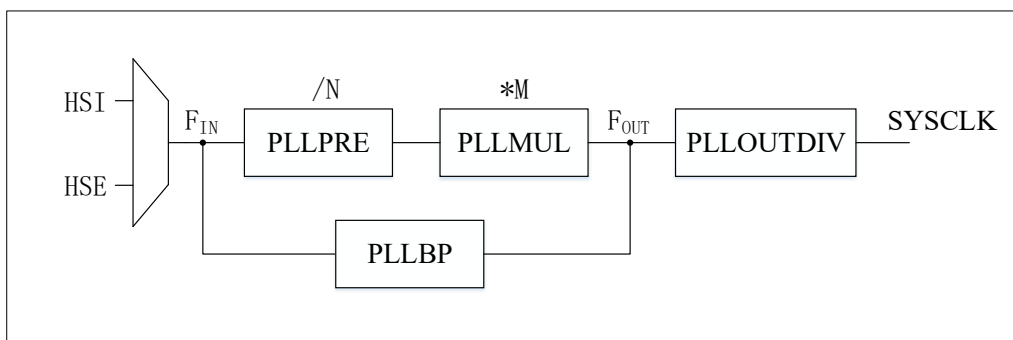
The input frequency  $F_{IN}$  range is from 4 to 20MHz.

PLL VCO( $F_{OUT}$ ) frequency range requires  $48\text{MHz} \leq F_{IN} * M/N < 72\text{MHz}$ .

The system frequency is derived from the PLL VCO frequency divided by the postscale factor, and it is needed to be configured correctly to avoid `SYSClk` exceeding 48MHz by the software.

In addition, user can also configure `RCC_CTRL.PLLBP` to bypass the PLL frequency division and frequency multiplication function.

**Figure 4-4 PLL Clock Configuration**



### 4.2.5 LSE Clock

The Low Speed External clock signal (LSE) can be generated from the following two clock sources:

- LSE crystal/ceramic resonator

- LSE external clock(bypass)

#### 4.2.5.1 LSE crystal clock source

The LSE crystal is a 32.768 kHz low-speed external crystal or ceramic resonator. It provides a low-power and accurate clock source for real-time clock or other timing functions.

The LSE clock can be switched on and switched off by setting the `RCC_LSCTRL.LSEEN` bit.

The `RCC_LSCTRL.LSERD` bit flag indicates if the LSE clock is stable. At startup, the LSE output clock is not released until this bit is set by hardware. An interrupt can be generated if enabled in the Clock Interrupt Register (`RCC_CLKINT`).

#### 4.2.5.2 LSE external clock source

In this mode, an external clock source with a frequency of up to 1 MHz can be provided. Users can select this mode by setting the `RCC_LSCTRL.LSEBP` (when `RCC_LSCTRL.LSEEN` disable) bits. The external clock signal(square, sinus or triangle wave) with 50% duty cycle must be connected to the `OSC32_IN` pin while the `OSC32_OUT` pin must be left floating (Hi-Z).

#### 4.2.6 LSI Clock

The LSI RC can provide clock for the IWDG and AWU in STOP mode. The LSI clock frequency is about 30KHz. Please refer to the electrical characteristics section of the data sheet for further information.

The LSI clock can be turned on or off using the `RCC_CTRLSTS.LSIEN` bit.

The `RCC_CTRLSTS.LSIRD` bit flag indicates if the LSI clock is stable. At startup, the clock is not released until this bit is set by hardware. An interrupt can be generated if enabled in the Clock Interrupt Register (`RCC_CLKINT`).

#### 4.2.7 System Clock (SYSCLK) Selection

After the system reset, the HSI oscillator is selected as the system clock. When the clock source is used as the system clock directly or indirectly through PLL, it is not possible to stop HSI.

A switch from one clock source to another occurs only if the target clock source is ready (after startup delay or PLL locked). When the selected clock source is not ready, the switching of the system clock will not happen.

`RCC_CFG.SCLKSW[1:0]` are used to select the system clock source. Status bits in `RCC_CTRL` and `RCC_LSCTRL` indicate which clock is ready, and `RCC_CFG` indicates which clock is currently used as the system clock.

#### 4.2.8 Clock Security System (CLKSS)

Clock security system can be activated by software by setting the `RCC_CTRL.CLKSEN` bit. Once activated, the clock detector is enabled after the startup delay of the HSE oscillator, and disabled when the HSE clock is turned off.

If the HSE clock fails, the HSE oscillator will be automatically turned off, and a clock failure event will be sent to the break input of the advanced timers (TIM1 and TIM8), and the Clock Security System Interrupt `CLKSSIF` will be generated, allowing the software to execute rescue operations. The `CLKSSIF` interrupt is connected to the NMI (Non-Maskable Interrupt) interrupt of the Cortex®-M0.

Once the CSS is activated and the HSE clock fails, the CSS interrupt is generated and the NMI is automatically generated. The NMI will be executed continuously until the CSS interrupt pending bit is cleared. Therefore, it is necessary to clear the CSS interrupt by setting the `RCC_CLKINT.CLKSSICLR` bit in the NMI handler.

If the HSE oscillator is directly or indirectly used as the system clock (indirectly means: it is used as the PLL input clock, and the PLL clock is used as the system clock), the clock failure will cause a switch of the system clock to the HSI oscillator and the disabling of the external HSE oscillator. If HSE clock (divided or not) is selected as PLL input clock then upon HSE clock failure, the PLL will be turned off.

#### 4.2.9 RTC Clock

By programming `RCC_LSCTRL.RTCSEL[1:0]` bits, the `RTCCLK` clock source can be the HSE/128, LSE, or LSI clocks.

#### 4.2.10 Watchdog Clock

If the independent watchdog has been started by hardware option or software, the LSI oscillator will be forced turned on and cannot be turned off. The clock is supplied to the IWDG after the LSI oscillator is stable.

#### 4.2.11 LPUART Clock

In normal operating mode, the LPUART clock supports six clock sources: HSI, HSE, LSI, LSE, `SYS_CLK` and `LPUART_PCLK`. Since HSI, HSE, `SYSCLK` and `PCLK` will be turned off in low power mode, software should switch the LPUART clock to LSI or LSE before entering low power mode..

#### 4.2.12 LPTIME Clock

In normal operating mode, the LPTIME clock supports six clock sources: HSI, HSE, LSI, LSE, `PCLK1` and `COMP_OUT`. Since HSI, HSE and `PCLK` will be turned off in low power mode, software should switch the LPTIMER clock to LSI, LSE or `COMP_OUT` before entering low power mode.

The switching without glitches between HSI, HSE, LSI, LSE, and `PCLK1`, software must ensure that both clocks are turned on before switching.

When switching from HSI, HSE, LSI, LSE, `PCLK1` to `COMP_OUT`, software cooperation is required:

1. Make sure the clock is on before switching
2. Set `COMP_CTRL.EN = 0`, make sure COMP off
3. Set `RCC_APB1PCKEN.LPTIMEN = 1`, turn on LPTIM
4. Set `RCC_CFG2.LPTIMSEL = 5`, select `COMP_OUT` as clock source
5. Set `COMP_CTRL.EN = 1`, turn on COMP

#### 4.2.13 Microcontroller Clock Output(MCO)

The microcontroller clock output (MCO) capability allows the clock signal to be output onto the external MCO pin.

The corresponding GPIO port register must be configured for the corresponding function. The following six clock signals can be selected as the MCO clock:

- `SYSCLK`
- HSI
- HSE
- LSI
- LSE

- PLL clock division

The selection is controlled by RCC\_CFG.MCO[2:0] bits.

## 4.3 RCC Registers

### 4.3.1 RCC Register Overview

Table 4-1 RCC Register Overview

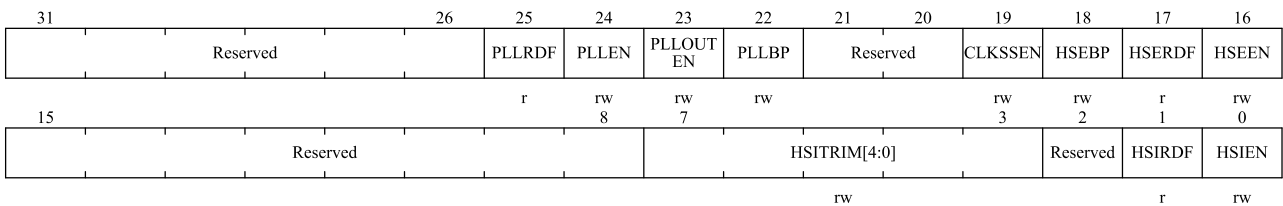
| Offset | Register      | 31           | 30       | 29       | 28        | 27       | 26 | 25     | 24              | 23           | 22              | 21       | 20     | 19        | 18        | 17             | 16       | 15             | 14      | 13            | 12       | 11           | 10       | 9        | 8            | 7           | 6         | 5        | 4            | 3        | 2        | 1        | 0        |         |          |            |         |          |
|--------|---------------|--------------|----------|----------|-----------|----------|----|--------|-----------------|--------------|-----------------|----------|--------|-----------|-----------|----------------|----------|----------------|---------|---------------|----------|--------------|----------|----------|--------------|-------------|-----------|----------|--------------|----------|----------|----------|----------|---------|----------|------------|---------|----------|
| 000h   | RCC_CTRL      | Reserved     |          |          |           |          |    |        |                 | PLL RDF      | PLLEN           | PLLOUTEN | PLLBP  | Reserved  |           |                |          |                |         |               |          | HSITRIM[4:0] |          |          |              | Reserved    | HSIRDF    | HSIEN    |              |          |          |          |          |         |          |            |         |          |
|        | Reset Value   |              |          |          |           |          |    |        |                 | 0            | 0               | 1        | 0      |           |           |                |          |                |         |               |          |              |          |          |              | 0           | 0         | 0        | 0            | 0        | 0        | 1        | 1        |         |          |            |         |          |
| 004h   | RCC_CFG       | MCORES [3:0] |          |          | MCO [2:0] |          |    | PLLSRC | PLLOUTDIV [1:0] | PLLPRE [1:0] | PLLMULFCT [3:0] |          |        | SCLKSTS2  |           | APB2PRES [2:0] |          | APB1PRES [2:0] |         | AHBPRES [3:0] |          |              | SCLKSTS  |          | SCLKSW [2:0] |             |           |          |              |          |          |          |          |         |          |            |         |          |
|        | Reset Value   | 0            | 0        | 1        | 0         | 0        | 0  | 0      | 0               | 0            | 0               | 0        | 0      | 0         | 0         | 0              | 0        | 0              | 0       | 0             | 0        | 0            | 0        | 0        | 0            | 0           | 0         | 0        | 0            | 0        | 0        | 0        | 0        |         |          |            |         |          |
| 008h   | RCC_CLKINT    | Reserved     |          |          |           |          |    |        |                 | CLKSSICLR    | Reserved        |          |        |           |           |                |          |                | PERCLR  | PLLRDCLR      | HSERDCLR | HSIRDCLR     | LSERDCLR | LSIRDCLR | Reserved     |             |           |          |              |          |          |          |          |         |          |            |         |          |
|        | Reset Value   |              |          |          |           |          |    |        |                 | 0            |                 |          |        |           |           |                |          |                | 0       | 0             | 0        | 0            | 0        | 0        | 0            | 0           |           |          |              |          |          |          |          |         |          |            |         |          |
| 00Ch   | RCC_APB2PRST  | Reserved     |          |          |           |          |    |        |                 |              |                 |          |        |           |           |                |          | USARTIRST      | TIM8RST | TIM1RST       | Reserved |              | SPI2RST  | SPI1RST  | Reserved     |             | IOPRST    | Reserved |              |          |          | IOPCRST  | IOPBRST  | IOPARST | Reserved |            | AFIORST |          |
|        | Reset Value   |              |          |          |           |          |    |        |                 |              |                 |          |        |           |           |                |          | 0              | 0       | 0             |          |              | 0        | 0        |              |             | 0         |          |              |          |          | 0        | 0        | 0       |          |            | 0       |          |
| 010h   | RCC_APB1PRST  | Reserved     | PWRRST   | Reserved |           |          |    |        |                 | I2C2RST      | I2C1RST         | Reserved |        | LPUARTRST | USART2RST | Reserved       |          |                |         |               |          | WWDGRST      | Reserved |          |              |             |           |          | BEEPRST      | TIM6RST  | LPTIMRST | Reserved |          | TIM3RST | Reserved |            |         |          |
|        | Reset Value   | 0            | 0        |          |           |          |    |        |                 | 0            | 0               |          |        | 0         | 0         |                |          |                |         |               |          | 0            |          |          |              |             |           |          | 0            | 0        | 0        |          |          | 0       | 0        |            |         |          |
| 014h   | RCC_AHBCLKEN  | Reserved     |          |          |           |          |    |        |                 |              |                 |          |        |           |           |                |          | ADCEN          |         | Reserved      |          |              |          |          |              | HDIVEN      | CRGEN     | HSQRTEN  | FLITFEN      | Reserved |          | SRAMEN   | Reserved |         | DMAEN    |            |         |          |
|        | Reset Value   |              |          |          |           |          |    |        |                 |              |                 |          |        |           |           |                |          | 0              |         |               |          |              |          |          |              | 0           | 0         | 0        | 0            | 0        | 0        | 0        | 0        | 0       |          |            | 0       | 0        |
| 018h   | RCC_APB2PCKEN | Reserved     |          |          |           |          |    |        |                 |              |                 |          |        |           |           |                |          | USART1EN       | TIM8EN  | TIM1EN        | Reserved |              | SPI2EN   | SPI1EN   | Reserved     |             | IOPFEN    | Reserved |              |          |          | IOPCEN   | IOPBEN   | IOPAEN  | Reserved |            | AFIOEN  |          |
|        | Reset Value   |              |          |          |           |          |    |        |                 |              |                 |          |        |           |           |                |          | 0              | 0       | 0             |          |              | 0        | 0        |              |             | 0         |          |              |          |          | 0        | 0        | 0       |          |            | 0       |          |
| 01Ch   | RCC_APB1PCKEN | OPAEN        | Reserved |          | PWREN     | Reserved |    |        |                 |              |                 | I2C2EN   | I2C1EN | Reserved  |           | LPUARTEN       | USART2EN | Reserved       |         |               |          |              |          | WWDGEN   | Reserved     |             | COMPFLTEN | COMPEN   | Reserved     |          |          |          | BEEPEN   | TIM6EN  | LPTIMEN  | LPTIMPCKEN | TIM3EN  | Reserved |
|        | Reset Value   | 0            |          |          | 0         |          |    |        |                 |              |                 | 0        | 0      |           |           | 0              | 0        |                |         |               |          |              |          | 0        |              |             | 0         | 0        |              |          |          |          | 0        | 0       | 0        | 0          | 0       |          |
| 020h   | RCC_LSCTRL    | Reserved     |          |          |           |          |    |        |                 |              |                 |          |        |           |           |                |          |                |         |               |          |              |          |          |              | LPRUNCLKSEL | RTCRST    | RTCEN    | RTCSEL [1:0] |          |          |          | LSEBYP   | LSERD   | LSEEN    | LSIRD      | LSIEN   |          |
|        | Reset Value   |              |          |          |           |          |    |        |                 |              |                 |          |        |           |           |                |          |                |         |               |          |              |          |          |              | 0           | 0         | 0        |              |          |          |          | 0        | 0       | 0        | 0          | 0       |          |

|      |             |          |          |  |  |                 |   |   |          |                |   |   |          |  |  |                 |           |            |          |          |          |          |          |                  |         |         |         |                |        |        |        |         |         |         |         |         |         |         |         |   |   |   |   |
|------|-------------|----------|----------|--|--|-----------------|---|---|----------|----------------|---|---|----------|--|--|-----------------|-----------|------------|----------|----------|----------|----------|----------|------------------|---------|---------|---------|----------------|--------|--------|--------|---------|---------|---------|---------|---------|---------|---------|---------|---|---|---|---|
| 024h | RCC_CTRLSTS | Reserved |          |  |  |                 |   |   |          |                |   |   |          |  |  | EMCCLPRSTF      | EMCGBRSTF | EMCGBNRSTF | LPWRKSTF | WWDGRSTF | IWDGRSTF | SFTRSTF  | PORRSTF  | PINRSTF          | MMURSTF | RAMRSTF | RMRSTF  |                |        |        |        |         |         |         |         |         |         |         |         |   |   |   |   |
|      | Reset Value |          |          |  |  |                 |   |   |          |                |   |   |          |  |  | 0               | 0         | 0          | 0        | 0        | 0        | 0        | 1        | 1                | 0       | 0       | 0       |                |        |        |        |         |         |         |         |         |         |         |         |   |   |   |   |
| 028h | RCC_AHBPRST | Reserved |          |  |  |                 |   |   |          |                |   |   |          |  |  | ADCRST          | Reserved  |            |          |          | HDIRVST  | Reserved | HISQTRST | Reserved         |         |         |         |                |        |        |        |         |         |         |         |         |         |         |         |   |   |   |   |
|      | Reset Value |          |          |  |  |                 |   |   |          |                |   |   |          |  |  | 0               |           |            |          |          | 0        |          | 0        |                  |         |         |         |                |        |        |        |         |         |         |         |         |         |         |         |   |   |   |   |
| 02Ch | RCC_CFG2    | TIMCLK   | Reserved |  |  | LPUARTSEL [2:0] |   |   | Reserved | LPTIMSEL [2:0] |   |   | Reserved |  |  | ADCIMPRES [4:0] |           |            |          | ADCIMSEL | Reserved |          |          | ADCPLLPRES [4:0] |         |         |         | ADCHPRES [3:0] |        |        |        |         |         |         |         |         |         |         |         |   |   |   |   |
|      | Reset Value | 0        |          |  |  | 0               | 0 | 0 |          | 0              | 0 | 0 |          |  |  | 0               | 0         | 1          | 1        | 1        | 0        |          |          |                  |         | 0       | 0       | 0              | 0      | 0      | 0      | 0       | 0       | 0       | 0       |         |         |         |         |   |   |   |   |
| 030h | RCC_EMCCTRL | Reserved |          |  |  |                 |   |   |          |                |   |   |          |  |  | GBRST3          | GBRST2    | GBRST1     | GBRST0   | GBNRST3  | GBNRST2  | GBNRST1  | GBNRST0  | CLPRST3          | CLPRST2 | CLPRST1 | CLPRST0 | GBDET3         | GBDET2 | GBDET1 | GBDET0 | GBNDET3 | GBNDET2 | GBNDET1 | GBNDET0 | CLPDET3 | CLPDET2 | CLPDET1 | CLPDET0 |   |   |   |   |
|      | Reset Value |          |          |  |  |                 |   |   |          |                |   |   |          |  |  | 0               | 0         | 0          | 0        | 0        | 0        | 0        | 0        | 0                | 0       | 0       | 0       | 0              | 0      | 0      | 0      | 0       | 0       | 0       | 0       | 0       | 0       | 0       | 0       | 0 | 0 | 0 | 0 |

### 4.3.2 Clock Control Register (RCC\_CTRL)

Address offset: 0x00

Reset value: 0x0080 0083



| Bit Field | Name     | Description  |
|-----------|----------|--|
| 31:26     | Reserved | Reserved, the reset value must be maintained   |
| 25        | PLLRDF   | PLL clock ready flag<br>Set by hardware once PLL is ready.<br>0: PLL is not ready<br>1: PLL is ready   |
| 24        | PLLEN    | PLL enable<br>Set and cleared by software. When entering the LPRUN,STOP or PD mode, it is cleared by hardware. This bit cannot be cleared when PLL is used as the system clock.<br>0: Disable PLL<br>1: Enable PLL |
| 23        | PLLOUTEN | PLL clock output enable bit.<br>0: PLL clock output is disabled<br>1: PLL clock output is enabled  |
| 22        | PLLBP    | PLL bypass mode<br>0: $F_{OUT} = F_{IN} * M / N$ (PLL VCO frequency)<br>1: $F_{OUT} = F_{IN}$ (bypass output)  |

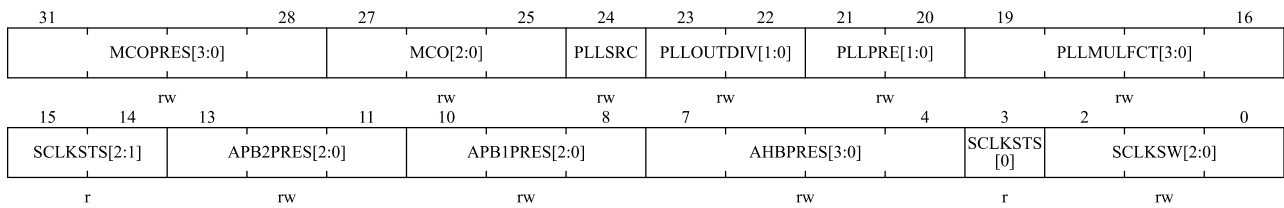


| Bit Field | Name         | Description  |
|-----------|--------------|--|
| 21:20     | Reserved     | Reserved, the reset value must be maintained.  |
| 19        | CLKSSSEN     | Clock security system enable<br>Set and cleared by software.<br>0: Disable the clock detector<br>1: Enable the clock detector if the HSE oscillator is ready   |
| 18        | HSEBP        | External high-speed clock bypass enable<br>Set and cleared by software. This bit can only be written when the HSE oscillator is disabled.<br>0: Disable the bypass function of HSE oscillator<br>1: Enable the bypass function of HSE oscillator   |
| 17        | HSERDF       | External high-speed clock ready flag<br>Set by hardware once HSE is ready. This bit is cleared 6 HSE clock cycles after the HSEEN bit is cleared.<br>0: HSE is not ready<br>1: HSE is ready  |
| 16        | HSEEN        | External high-speed clock enable<br>Set and cleared by software. When entering the LPRUN,STOP or PD mode, it is cleared by hardware. This bit cannot be cleared when HSE is used as the system clock.<br>0: Disable HSE oscillator<br>1: Enable HSE oscillator   |
| 15:8      | Reserved     | Reserved, the reset value must be maintained.  |
| 7:3       | HSITRIM[4:0] | Internal high-speed clock correction value<br>written by software, used to calibrate the frequency of the internal HSI RC oscillator.<br>Fine adjustment: $\text{current value} + (\text{measured frequency} - \text{target frequency} : 8\text{M}) / (8\text{M} * 0.33\%)$ integer;<br>The default value is 16, and the HSI can be adjusted to 8MHz±0.3%. According to application to obtain higher accuracy; |
| 2         | Reserved     | Reserved, the reset value must be maintained.  |
| 1         | HSIRDF       | Internal high-speed clock ready flag<br>Set by hardware once HSI is stable. After the HSIEN bit is cleared, it takes 6 internal 8 MHz oscillator clock cycles to go low.   |
| 0         | HSIEN        | Internal high-speed clock enable<br>Set and cleared by software. This bit cannot be cleared when HSI is used as the system clock. When returning from LPRUN,STOP or PD mode or HSE failure occurs, set by hardware to enable the HSI oscillator.<br>0: Disable HSI oscillator<br>1: Enable HSI oscillator  |

### 4.3.3 Clock Configuration Register (RCC\_CFG)

Address offset: 0x04

Reset value: 0x2000 0000



| Bit Field | Name         | Description   |
|-----------|--------------|---|
| 31:28     | MCOPRES[3:0] | <p>MCO prescaler</p> <p>Set and cleared by software.</p> <p>0010: PLL clock divided by 2</p> <p>0011: PLL clock divided by 3</p> <p>0100: PLL clock divided by 4</p> <p>0101: PLL clock divided by 5</p> <p>0110: PLL clock divided by 6</p> <p>0111: PLL clock divided by 7</p> <p>1000: PLL clock divided by 8</p> <p>1001: PLL clock divided by 9</p> <p>1010: PLL clock divided by 10</p> <p>1011: PLL clock divided by 11</p> <p>1100: PLL clock divided by 12</p> <p>1101: PLL clock divided by 13</p> <p>1110: PLL clock divided by 14</p> <p>1111: PLL clock divided by 15</p> <p>Other values: not allowed</p> |
| 27:25     | MCO[2:0]     | <p>Microcontroller clock output selection</p> <p>Set and cleared by software.</p> <p>000: no clock</p> <p>001: LSI clock</p> <p>010: LSE clock</p> <p>011: System clock (SYSCLK)</p> <p>100: HSI clock</p> <p>101: HSE clock</p> <p>110: Clock after PLL frequency division</p> <p><i>Note: This clock output may be truncated at startup or during MCO clock source switching. When the system clock is selected to output to the MCO pin, the output clock frequency must not exceed the maximum I/O speed (For details of the maximum frequency of the I/O port, see the data sheet).</i></p>                        |
| 24        | PLLSRC       | <p>PLL clock source.</p> <p>Set or cleared by software, this bit can be written only when the PLL is turned off.</p> <p>0: HSI clock is used as PLL input clock</p>   |

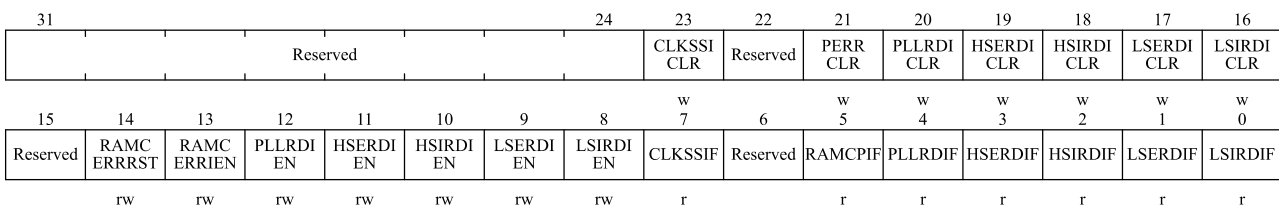
| Bit Field | Name           | Description  |
|-----------|----------------|--|
|           |                | 1: HSE clock is used as PLL input clock  |
| 23:22     | PLLOUTDIV[1:0] | The PLL outputs the clock division value.<br>Set and clear through software.<br>00: no frequency division<br>01: divided by 2<br>10: divided by 3<br>11: divided by 4  |
| 21:20     | PLLPRE[1:0]    | PLL prescaler<br>$4\text{MHz} \leq F_{\text{IN}}/N \leq 20\text{MHz}$<br>This bit can only be written when the PLL is off<br>00: PLL input clock divided by 1<br>01: PLL input clock divided by 2<br>10: PLL input clock divided by 3<br>11: PLL input clock divided by 4                                      |
| 19:16     | PLLMULFCT[3:0] | PLL multiplication factor.<br>Set and clear through software. This bit can only be written when the PLL is off.<br>$F_{\text{OUT}} = F_{\text{IN}} * M / N$<br>The actual PLL M value should be this register value + 3, $M = \text{PLLMULFCT} + 3$ .<br>0: M = 3<br>1: M = 4<br>2: M = 5<br>...<br>15: M = 18 |
| 15:14     | SCLKSTS2[1:0]  | Use with SCLKSTS bit   |
| 13:11     | APB2PRES[2:0]  | APB high-speed (APB2) prescaler<br>Set and cleared by software to configure the division factor of APB2 clock (PCLK2).<br>Make sure that PCLK2 does not exceed 48MHz.<br>0xx: HCLK not divided<br>100: HCLK divided by 2<br>101: HCLK divided by 4<br>110: HCLK divided by 8<br>111: HCLK divided by 16        |
| 10:8      | APB1PRES[2:0]  | APB low-speed (APB1) prescaler<br>Set and cleared by software to configure the division factor of the APB1 clock (PCLK1). Make sure that PCLK1 does not exceed 48MHz.<br>0xx: HCLK not divided<br>100: HCLK divided by 2<br>101: HCLK divided by 4<br>110: HCLK divided by 8<br>111: HCLK divided by 16        |
| 7:4       | AHBPRES[3:0]   | AHB prescaler  |

| Bit Field | Name        | Description   |
|-----------|-------------|---|
|           |             | Set and cleared by software to configure the division factor of the AHB clock (HCLK).<br>0xxx: SYSCLK not divided<br>1000: SYSCLK divided by 2<br>1001: SYSCLK divided by 4<br>1010: SYSCLK divided by 8<br>1011: SYSCLK divided by 16<br>1100: SYSCLK divided by 64<br>1101: SYSCLK divided by 128<br>1110: SYSCLK divided by 256<br>1111: SYSCLK divided by 512   |
| 3         | SCLKSTS     | System clock switch status, used together with SCLKSTS2[1:0] bit<br>Set and cleared by hardware to indicate which clock source is used as system clock<br>000: HSI oscillator used as system clock<br>001: HSE oscillator used as system clock<br>010: PLL used as system clock<br>011: LSE used as system clock<br>100: LSI used as system clock   |
| 2:0       | SCLKSW[2:0] | System clock switch<br>Set and cleared by software to select the system clock source.<br>Set by hardware to force HSI selection when exiting from the STOP mode, or when the HSE oscillator fails and CLKSSSEN is enabled.<br>000: HSI selected as the system clock<br>001: HSE selected as the system clock<br>010: PLL selected as the system clock<br>011: LSE selected as the system clock<br>100: LSI selected as the system clock |

### 4.3.4 Clock Interrupt Register (RCC\_CLKINT)

Address offset: 0x08

Reset value: 0x0000 0000



| Bit Field | Name      | Description                                   |
|-----------|-----------|---|
| 31:24     | Reserved  | Reserved, the reset value must be maintained. |
| 23        | CLKSSICLR | Clock security system interrupt clear         |

| Bit Field | Name       | Description  |
|-----------|------------|--|
|           |            | Set by the software to clear the CLKSSIF flag.<br>0: No effect<br>1: Clear the CLKSSIF flag  |
| 22        | Reserved   | Reserved, the reset value must be maintained.  |
| 21        | PERRCLR    | PERRCLR: Clears PERR interrupts.<br>This bit is set by the software to clear PERRF.<br>0: No impact.<br>1: PERRF cleared   |
| 20        | PLLRDICLR  | PLL ready interrupt clear<br>Set by the software to clear the PLLRDIF flag.<br>0: No effect<br>1: Clear the PLLRDIF flag   |
| 19        | HSERDICLR  | HSE ready interrupt clear<br>Set by the software to clear the HSERDIF flag.<br>0: Not used<br>1: Clear HSERDIF flag  |
| 18        | HSIRDICLR  | HSI ready interrupt clear<br>Set by the software to clear the HSIRDIF flag.<br>0: Not used<br>1: Clear the HSIRDIF flag  |
| 17        | LSERDICLR  | LSE ready interrupt clear<br>Set by the software to clear the LSERDIF flag.<br>0: Not used<br>1: Clear LSERDIF flag  |
| 16        | LSIRDICLR  | LSI ready interrupt clear<br>Set by software to clear the LSIRDIF flag.<br>0: Not used<br>1: Clear the LSIRDIF flag  |
| 15        | Reserved   | Reserved, the reset value must be maintained.  |
| 14        | RAMCERRRST | RAMC parity error reset enabled<br>1: RAMC generates a reset when it detects a parity error<br>0: The reset is not generated when RAMC detects a parity error          |
| 13        | RAMCERRIEN | Enable RAMC parity error interrupt<br>1: Interrupts when RAMC detects a parity error<br>0: No interrupt is generated when RAMC detects a parity error                  |
| 12        | PLLRDIEN   | PLL ready interrupt enable<br>Set and cleared by software to enable and disable PLL ready interrupt<br>0: Disable PLL ready interrupt<br>1: Enable PLL ready interrupt |
| 11        | HSERDIEN   | HSE ready interrupt enable<br>Set and cleared by software to enable and disable HSE ready interrupt.   |

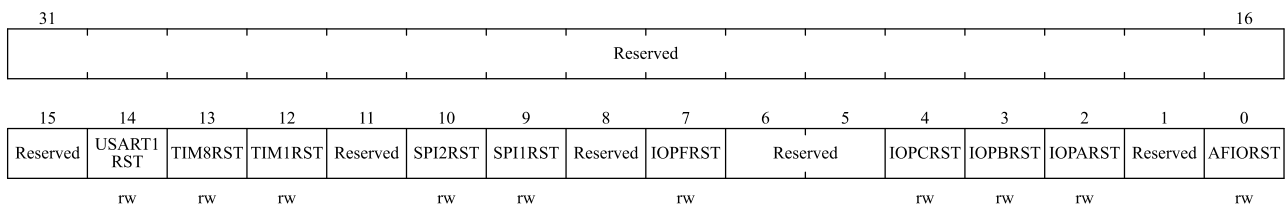
| Bit Field | Name      | Description  |
|-----------|-----------|--|
|           |           | 0: Disable HSE ready interrupt<br>1: Enable HSE Ready Interrupt  |
| 10        | HSIRDIEN  | HSI ready interrupt enable<br>Set and cleared by software to enable and disable HSI ready interrupt.<br>0: Disable HSI ready interrupt<br>1: Enable HSI ready interrupt  |
| 9         | LSERDIEN  | LSE ready interrupt enable<br>Set and cleared by software to enable and disable LSE ready interrupt.<br>0: Disable LSE ready interrupt<br>1: Enable LSE ready interrupt  |
| 8         | LSIRDIEEN | LSI ready interrupt enable<br>Set and cleared by software to enable and disable LSI ready interrupt.<br>0: Disable LSI ready interrupt<br>1: Enable LSI ready interrupt  |
| 7         | CLKSSIF   | Clock security system interrupt flag<br>Set by hardware when a failure is detected in the external HSE oscillator.<br>0: No clock security system interrupt caused by HSE clock failure<br>1: Clock security system interrupt caused by HSE clock failure                  |
| 6         | Reserved  | Reserved, the reset value must be maintained.  |
| 5         | RAMCPIF   | RAMC parity interrupt status. Set by hardware, set by software to clear PERRCLR<br>1: RAMC parity error occurs<br>0: No RAMC parity error occurs   |
| 4         | PLLRDIF   | PLL ready interrupt flag<br>This bit is set by hardware when PLLRDIEN is set and PLL clock is ready.<br>This bit is cleared by software by setting the PLLRDICLR bit.<br>0: No clock ready interrupt caused by PLL lock<br>1: Clock ready interrupt caused by PLL lock     |
| 3         | HSERDIF   | HSE ready interrupt flag<br>Set by hardware when HSERDIEN is set and the HSE clock is ready.<br>This bit is cleared by software by setting the HSERDICLR bit.<br>0: No clock ready interrupt caused by HSE oscillator<br>1: Clock ready interrupt caused by HSE oscillator |
| 2         | HSIRDIF   | HSI ready interrupt flag<br>Set by hardware when HSIRDIEN is set and the HSI clock is ready.<br>This bit is cleared by software by setting the HSERDICLR bit.<br>0: No clock ready interrupt caused by HSI oscillator<br>1: Clock ready interrupt caused by HSI oscillator |
| 1         | LSERDIF   | LSE ready interrupt flag<br>Set by hardware when LSERDIEN is set and the LSE clock is ready.<br>This bit is cleared by the software by setting the LSERDICLR bit.<br>0: No clock ready interrupt caused by LSE oscillator  |

| Bit Field | Name    | Description   |
|-----------|---------|---|
|           |         | 1: Clock ready interrupt caused by LSE oscillator   |
| 0         | LSIRDIF | LSI ready interrupt flag<br>Set by the hardware when LSIRDIFEN is set and the LSI clock is ready.<br>This bit is cleared by software by setting the LSIRDICLR bit.<br>0: No clock ready interrupt caused by LSI oscillator<br>1: Clock ready interrupt caused by LSI oscillator |

### 4.3.5 APB2 Peripheral Reset Register (RCC\_APB2PRST)

Address offset: 0x0c

Reset value: 0x0000 0000



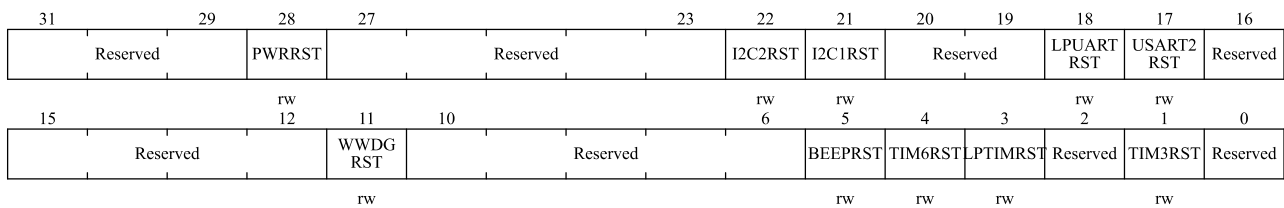
| Bit Field | Name      | Description   |
|-----------|-----------|---|
| 31:15     | Reserved  | Reserved, the reset value must be maintained.                                     |
| 14        | USART1RST | USART1 reset<br>Set and cleared by software.<br>0: Clear reset<br>1: Reset USART1 |
| 13        | TIM8RST   | TIM8 reset<br>Set and cleared by software.<br>0: Clear reset<br>1: Reset TIM8     |
| 12        | TIM1RST   | TIM1 reset<br>Set and cleared by software.<br>0: Clear reset<br>1: Resets TIM1    |
| 11        | Reserved  | Reserved, the reset value must be maintained.                                     |
| 10        | SPI2RST   | SPI2 reset<br>Set and cleared by software.<br>0: Clear reset<br>1: Reset SPI2     |
| 9         | SPI1RST   | SPI1 reset<br>Set and cleared by software.<br>0: Clear reset<br>1: Reset SPI1     |
| 8         | Reserved  | Reserved, the reset value must be maintained.                                     |

| Bit Field | Name     | Description   |
|-----------|----------|---|
| 7         | IOPFRST  | GPIO port F reset<br>Set and cleared by software.<br>0: Clear reset<br>1: Reset GPIO port F                     |
| 6:5       | Reserved | Reserved, the reset value must be maintained.   |
| 4         | IOPCRST  | GPIO port C reset<br>Set and cleared by software.<br>0: Clear reset<br>1: Reset GPIO port C                     |
| 3         | IOPBRST  | GPIO port B reset<br>Set and cleared by software.<br>0: Clear reset<br>1: Reset GPIO port B                     |
| 2         | IOPARST  | GPIO port A reset<br>Set and cleared by software.<br>0: Clear reset<br>1: Reset GPIO port A                     |
| 1         | Reserved | Reserved, the reset value must be maintained.   |
| 0         | AFIORST  | Alternate function IO reset<br>Set and cleared by software.<br>0: Clear reset<br>1: Reset alternate function IO |

### 4.3.6 APB1 Peripheral Reset Register (RCC\_APB1PRST)

Address offset: 0x10

Reset value: 0x0000 0000



| Bit Field | Name     | Description   |
|-----------|----------|---|
| 31:29     | Reserved | Reserved, the reset value must be maintained  |
| 28        | PWRRST   | Power interface reset<br>Set and cleared by software.<br>0: Clear reset<br>1: Reset the power interface |
| 27:23     | Reserved | Reserved, the reset value must be maintained  |
| 22        | I2C2RST  | I <sup>2</sup> C2 reset   |

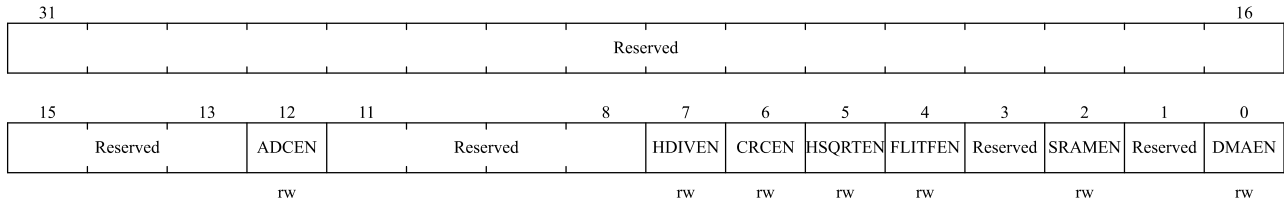


| Bit Field | Name      | Description   |
|-----------|-----------|---|
|           |           | Set and cleared by software.<br>0: Clear reset<br>1: Reset I <sup>2</sup> C2                            |
| 21        | I2C1RST   | I <sup>2</sup> C1 reset<br>Set and cleared by software.<br>0: Clear reset<br>1: Reset I <sup>2</sup> C1 |
| 20:19     | Reserved  | Reserved, the reset value must be maintained.   |
| 18        | LPUARTRST | LPUART reset<br>Set and cleared by software.<br>0: Clear reset<br>1: Reset LPUART                       |
| 17        | USART2RST | USART2 reset<br>Set and cleared by software.<br>0: Clear reset<br>1: Reset USART2                       |
| 16:12     | Reserved  | Reserved, the reset value must be maintained  |
| 11        | WWDGRST   | Window watchdog reset<br>Set and cleared by software.<br>0: Clear reset<br>1: Reset window watchdog     |
| 10:6      | Reserved  | Reserved, the reset value must be maintained  |
| 5         | BEEPRST   | BEEPER reset<br>Set and cleared by software.<br>0: Clear reset<br>1: Reset BEEPER                       |
| 4         | TIM6RST   | <b>TIM6 timer reset</b><br>Set and cleared by software.<br>0: Clear reset<br>1: Reset TIM6 timer        |
| 3         | LPTIMRST  | LPTIMR timer reset<br>Set and cleared by software.<br>0: Clear reset<br>1: Reset LPTIM                  |
| 2         | Reserved  | Reserved, the reset value must be maintained  |
| 1         | TIM3RST   | TIM3 timer reset<br>Set and cleared by software.<br>0: Clear reset<br>1: Reset TIM3 timer               |
| 0         | Reserved  | Reserved, the reset value must be maintained.   |

### 4.3.7 AHB Peripheral Clock Enable Register (RCC\_AHBCLKEN)

Address offset: 0x14

Reset value: 0x0000 0014



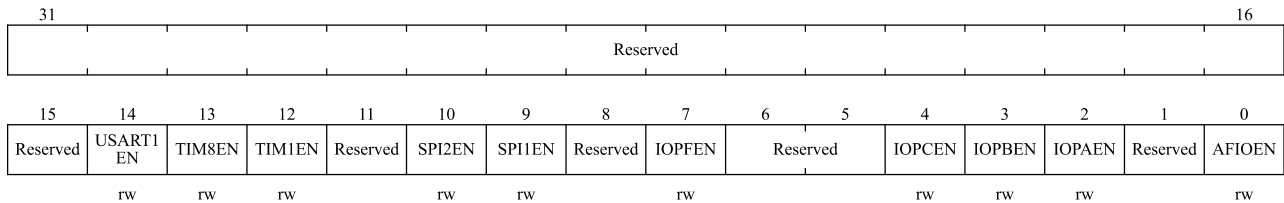
| Bit Field | Name     | Description   |
|-----------|----------|---|
| 31:13     | Reserved | Reserved, the reset value must be maintained.   |
| 12        | ADCEN    | ADC clock enable<br>Set and cleared by software.<br>0: Disable ADC clock<br>1: Enable ADC clock   |
| 11:8      | Reserved | Reserved, the reset value must be maintained.   |
| 7         | HDIVEN   | HDIV clock enable<br>Set and cleared by software.<br>0: Disable the HDIV clock<br>1: Enable the HDIV clock.                                 |
| 6         | CRCEN    | CRC clock enable<br>Set and cleared by software.<br>0: Disable CRC clock<br>1: Enable CRC clock   |
| 5         | HSQRTEN  | HSQRT clock enable<br>Set and cleared by software.<br>0: Disable HSQRT clock<br>1: Enable HSQRT clock                                       |
| 4         | FLITFEN  | Flash interface clock enable<br>Set and cleared by software.<br>0: Disable the Flash interface clock<br>1: Enable the Flash interface clock |
| 3         | Reserved | Reserved, the reset value must be maintained.   |
| 2         | SRAMEN   | SRAM clock enable<br>Set and cleared by software.<br>0: SRAM clock disabled in sleep mode<br>1: SRAM clock enabled in sleep mode            |
| 1         | Reserved | Reserved, the reset value must be maintained.   |
| 0         | DMAEN    | DMA clock enable<br>Set and cleared by software.  |

| Bit Field | Name | Description                                 |
|-----------|------|---|
|           |      | 0: Disable DMA clock<br>1: Enable DMA clock |

### 4.3.8 APB2 Peripheral Clock Enable Register (RCC\_APB2PCLKEN)

Address offset: 0x18

Reset value: 0x0000 0000



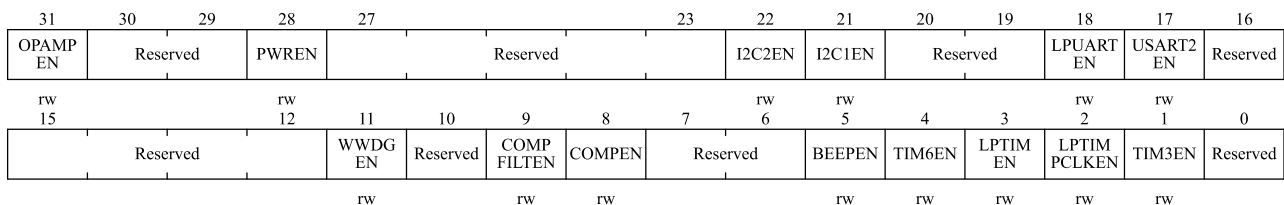
| Bit Field | Name     | Description   |
|-----------|----------|---|
| 31:15     | Reserved | Reserved, the reset value must be maintained.   |
| 14        | USART1EN | USART1 clock enable<br>Set and cleared by software.<br>0: Disable USART1 clock<br>1: Enable USART1 clock                              |
| 13        | TIM8EN   | TIM8 Clock Enable<br>Set and cleared by software.<br>0: Disable TIM8 clock<br>1: Enable TIM8 clock                                    |
| 12        | TIM1EN   | TIM1 clock enable<br>Set and cleared by software.<br>0: Disable TIM1 clock<br>1: Enable TIM1 clock                                    |
| 11        | Reserved | Reserved, the reset value must be maintained.   |
| 10        | SPI2EN   | SPI2 clock enable<br>Set and cleared by software.<br>0: Disable SPI2 clock<br>1: Enable SPI2 clock                                    |
| 9         | SPI1EN   | SPI1 clock enable<br>Set and cleared by software.<br>0: Disable SPI1 clock<br>1: Enable SPI1 clock                                    |
| 8         | Reserved | Reserved, the reset value must be maintained.   |
| 7         | IOPFEN   | GPIO port F clock enable<br>Set and cleared by software.<br>0: Disable the clock of GPIO port F<br>1: Enable the clock of GPIO port F |

| Bit Field | Name     | Description   |
|-----------|----------|---|
| 6:5       | Reserved | Reserved, the reset value must be maintained.   |
| 4         | IOPCEN   | GPIO port C clock enable<br>Set and cleared by software.<br>0: Disable the clock of GPIO port C<br>1: Enable the clock of GPIO port C                         |
| 3         | IOPBEN   | GPIO port B clock enable<br>Set and cleared by software.<br>0: Disable the clock of GPIO port B<br>1: Enable the clock of GPIO port B                         |
| 2         | IOPAEN   | GPIO port A clock enable<br>Set and cleared by software.<br>0: Disable the clock of GPIO port A<br>1: Enable the clock of GPIO port A                         |
| 1         | Reserved | Reserved, the reset value must be maintained.   |
| 0         | AFIOEN   | Alternate function IO clock enable<br>Set and cleared by software.<br>0: Disable the alternate function IO clock<br>1: Enable the alternate function IO clock |

### 4.3.9 APB1 Peripheral Clock Enable Register (RCC\_APB1PCLKEN)

Address offset: 0x1c

Reset value: 0x0000 0000



| Bit Field | Name     | Description   |
|-----------|----------|---|
| 31        | OPAMPEN  | OPAMP clock enable<br>Set and cleared by software.<br>0: Disable OPAMP clock<br>1: Enable OPAMP clock                                       |
| 30:29     | Reserved | Reserved, the reset value must be maintained  |
| 28        | PWREN    | Power interface clock enable<br>Set and cleared by software.<br>0: Disable the power interface clock<br>1: Enable the power interface clock |
| 27:23     | Reserved | Reserved, the reset value must be maintained  |
| 22        | I2C2EN   | I <sup>2</sup> C2 clock enable  |

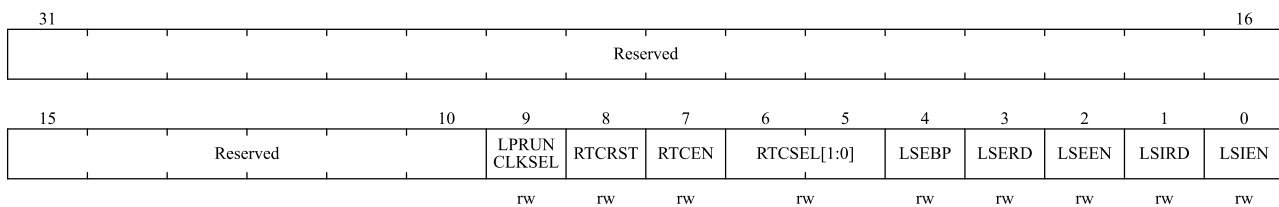
| Bit Field | Name       | Description   |
|-----------|------------|---|
|           |            | Set and cleared by software.<br>0: Disable I <sup>2</sup> C2 clock<br>1: Enable I <sup>2</sup> C2 clock                                   |
| 21        | I2C1EN     | I <sup>2</sup> C1 clock enable<br>Set and cleared by software.<br>0: Disable I <sup>2</sup> C1 clock<br>1: Enable I <sup>2</sup> C1 clock |
| 20:19     | Reserved   | Reserved, the reset value must be maintained  |
| 18        | LPUARTEN   | LPUART clock enable<br>Set and cleared by software.<br>0: Disable LPUART clock<br>1: Enable LPUART clock                                  |
| 17        | USART2EN   | USART2 clock enable<br>Set and cleared by software.<br>0: Disable USART2 clock<br>1: Enable USART2 clock                                  |
| 16:12     | Reserved   | Reserved, the reset value must be maintained  |
| 11        | WWDGEN     | Window watchdog clock enable<br>Set and cleared by software.<br>0: Disable WWDG clock<br>1: Enable WWDG clock                             |
| 10        | Reserved   | Reserved, the reset value must be maintained  |
| 9         | COMPFILTEN | Comparator filter clock enable<br>0: Disable the comparator filter clock<br>1: Enable the comparator filter clock                         |
| 8         | COMPEN     | Comparator clock enable<br>0: Disable the comparator clock<br>1: Enable the comparator clock  |
| 7:6       | Reserved   | Reserved, the reset value must be maintained  |
| 5         | BEEPEN     | BEEPER clock enable<br>Set and cleared by software.<br>0: Disable BEEPER clock<br>1: Enable BEEPER clock                                  |
| 4         | TIM6EN     | TIM6 timer clock enable<br>Set and cleared by software.<br>0: Disable TIM6 timer clock<br>1: Enable TIM6 timer clock                      |
| 3         | LPTIMEN    | LPTIM timer clock enable<br>Set and cleared by software.<br>0: Disable LPTIM timer clock<br>1: Enable LPTIM timer clock                   |

| Bit Field | Name        | Description  |
|-----------|-------------|--|
| 2         | LPTIMPCLKEN | LPTIM APB1 interface clock enable<br>It needs to be enabled only when LPTIM selects APB1 as the timer clock source.<br>When LPTIM selects other clock sources, this clock is turned off to save power.<br>Set or cleared by software.<br>0: Disable the LPTIM APB1 interface clock<br>1: Enable the LPTIM APB1 interface clock |
| 1         | TIM3EN      | TIM3 timer clock enable<br>Set and cleared by software.<br>0: Disable TIM3 timer clock<br>1: Enable TIM3 timer clock   |
| 0         | Reserved    | Reserved, the reset value must be maintained   |

### 4.3.10 Low Speed Clock Control Register (RCC\_LSCTRL)

Address offset: 0x20

Reset value: 0x0000 0003



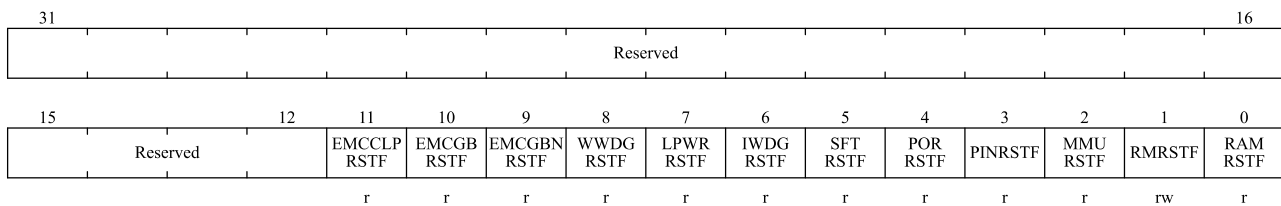
| Bit Field | Name        | Description  |
|-----------|-------------|--|
| 31:10     | Reserved    | Reserved, the reset value must be maintained   |
| 9         | LPRUNCLKSEL | LPRUN clock selection<br>Set and clear by software<br>0: LPRUN mode selects LSI clock<br>1: LPRUN mode selects LSE clock   |
| 8         | RTCRST      | RTC software reset<br>0: Clear reset<br>1: Reset RTC   |
| 7         | RTCEN       | RTC clock enable<br>Set and clear by software<br>0: RTC clock disabled<br>1: RTC clock is enabled  |
| 6:5       | RTCSEL[1:0] | RTC clock source selection.<br>The software sets these bits to select the RTC clock source.<br>00: no clock<br>01: Select LSE oscillator as RTC clock<br>10: Select LSI oscillator as RTC clock<br>11: Select the HSE oscillator divided by 128 as the RTC clock |

| Bit Field | Name  | Description   |
|-----------|-------|---|
| 4         | LSEBP | The external low-speed clock oscillator is bypassed.<br>Set by software to bypass LSE. At this time LSEEN needs to be set 0<br>0: LSE clock is not bypassed<br>1: LSE clock is bypassed<br>This bit cannot be reset by system reset |
| 3         | LSERD | External low-speed oscillator ready flag<br>Set by hardware once LSE is ready. After LSIEN is cleared, LSIRD is cleared after 6 external low-speed oscillator clock cycles.<br>0: LSE is not ready<br>1: LSE is ready               |
| 2         | LSEEN | External low-speed oscillator enable<br>Set and cleared by software<br>0: Disable LSE oscillator<br>1: Enable LSE oscillator  |
| 1         | LSIRD | Internal low-speed ready oscillator flag<br>Set by hardware once LSI is ready. After LSIEN is cleared, LSIRD is cleared after 3 internal low-speed oscillator clock cycles.<br>0: LSI is not ready<br>1: LSI is ready               |
| 0         | LSIEN | Internal low-speed oscillator enable<br>Set and cleared by software<br>0: Disable LSI oscillator<br>1: Enable LSI oscillator  |

### 4.3.11 Control/Status Register (RCC\_CTRLSTS)

Address offset: 0x24

Reset value: 0x0000 0018



| Bit Field | Name       | Description  |
|-----------|------------|--|
| 31:12     | Reserved   | Reserved, the reset value must be maintained   |
| 11        | EMCCLPRSTF | EMCCLAMP reset flag<br>Set by hardware when EMCCLAMP is reset.<br>It is cleared by writing RMRSTF bit or por_rst_n reset.<br>0: No EMCCLAMP reset occurred<br>1: EMCCLAMP reset occurred |

| Bit Field | Name       | Description  |
|-----------|------------|--|
| 10        | EMCGBRSTF  | EMCGB reset flag<br>Set by hardware when EMCGB is reset.<br>It is cleared by writing RMRSTF bit or por_rst_n reset.<br>0: No EMCGB reset occurred<br>1: EMCGB reset occurred   |
| 9         | EMCGBNRSTF | EMCGBN reset flag<br>Set by hardware when EMCGBN is reset.<br>It is cleared by writing RMRSTF bit or por_rst_n reset.<br>0: No EMCGBN reset occurred<br>1: EMCGBN reset occurred   |
| 8         | LPWRRSTF   | Low-power reset flag<br>Set by hardware at Low-power reset.<br>It is cleared by writing RMRSTF bit or por_rst_n reset.<br>0: No Low-power reset occurred<br>1: Low-power reset occurred  |
| 7         | WWDGRSTF   | Window watchdog reset flag<br>Set by hardware when an Window watchdog reset occurs<br>It is cleared by writing RMRSTF bit or por_rst_n reset.<br>0: No Window watchdog reset occurred<br>1: Window watchdog reset occurred                     |
| 6         | IWDGRSTF   | Independent watchdog reset flag<br>Set by hardware when an independent watchdog reset occurs<br>It is cleared by writing RMRSTF bit or por_rst_n reset.<br>0: No independent watchdog reset occurred<br>1: Independent watchdog reset occurred |
| 5         | SFTRSTF    | Software reset flag<br>Set by hardware when a software reset occurs.<br>It is cleared by writing RMRSTF bit or por_rst_n reset.<br>0: No software reset occurred<br>1: Software reset occurred   |
| 4         | PORRSTF    | POR/PDR reset flag<br>Set by hardware when POR/PDR is reset.<br>Cleared by writing to the RMRSTF bit<br>0: No POR/PDR reset occurred<br>1: POR/PDR reset occurred  |
| 3         | PINRSTF    | External pin reset flag<br>Set by hardware when a reset from the NRST pin occurs.<br>It is cleared by writing RMRSTF bit or por_rst_n reset.<br>0: No NRST pin reset occurred<br>1: NRST pin reset occurred                                    |
| 2         | MMURSTF    | MMU reset flag   |

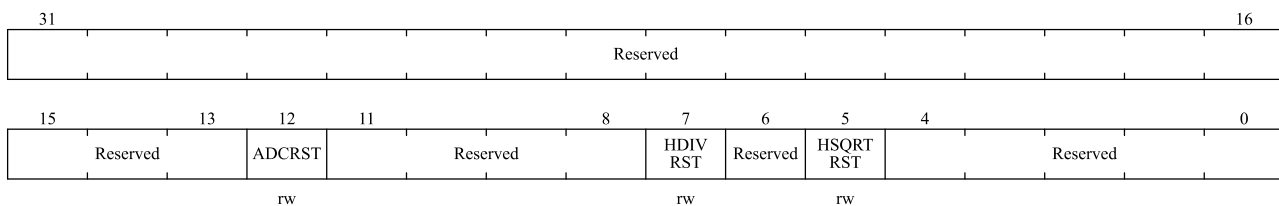


| Bit Field | Name    | Description  |
|-----------|---------|--|
|           |         | Set by hardware when MMU reset occurs.<br>It is cleared by writing RMRSTF bit or por_rst_n reset.<br>0: No MMU reset occurred<br>1: MMU reset occurred                   |
| 1         | RAMRSTF | RAM reset flag<br>Set by hardware when RAM reset occurs.<br>It is cleared by writing RMRSTF bit or por_rst_n reset.<br>0: No RAM reset occurred<br>1: RAM reset occurred |
| 0         | RMRSTF  | REMOVE reset flag<br>Set and clear by software<br>0: No effect<br>1: Clear these reset flags   |

### 4.3.12 AHB Peripheral Reset Register (RCC\_AHBPRST)

Address offset: 0x28

Reset value: 0x0000 0000

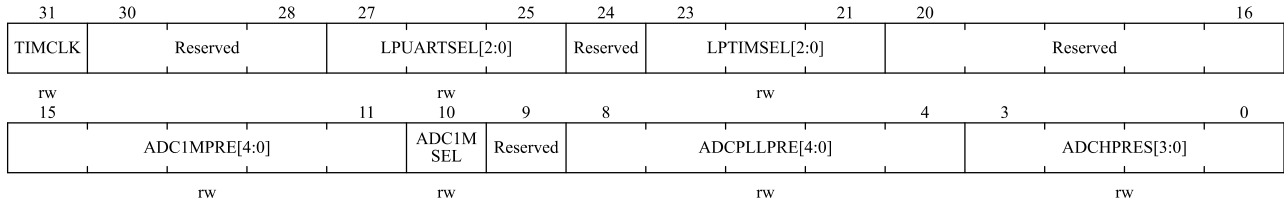


| Bit Field | Name     | Description   |
|-----------|----------|---|
| 31:13     | Reserved | Reserved, the reset value must be maintained.                                   |
| 12        | ADCRST   | ADC reset<br>Set and cleared by software.<br>0: Clear reset<br>1: Reset ADC     |
| 11:8      | Reserved | Reserved, the reset value must be maintained.                                   |
| 7         | HDIVRST  | HDIV reset<br>Set and cleared by software.<br>0: Clear reset<br>1: Reset HDIV   |
| 6         | Reserved | Reserved, the reset value must be maintained.                                   |
| 5         | HSQRTRST | HSQRT reset<br>Set and cleared by software.<br>0: Clear reset<br>1: Reset HSQRT |
| 4:0       | Reserved | Reserved, the reset value must be maintained.                                   |

### 4.3.13 Clock Configuration Register 2(RCC\_CFG2)

Address offset: 0x2c

Reset value: 0x0000 3800



| BitField | Name           | Description  |
|----------|----------------|--|
| 31       | TIMCLK         | TIM1/8 clock source selection<br>Set and cleared by software.<br>0: PCLK2 is selected as TIM1/8 clock source if APB2 prescaler is 1. Otherwise, PCLK2 × 2 is selected.<br>1: SYSCLK input clock is selected as TIM1/8 clock source.  |
| 30:28    | Reserved       | Reserved, the reset value must be maintained.  |
| 27:25    | LPUARTSEL[2:0] | LPUART clock source selection<br>Set and cleared by software.<br>000: APB1 clock is selected<br>001: System clock is selected<br>010: HSI clock is selected<br>011: HSE clock is selected<br>100: LSI clock is selected<br>101: LSE clock is selected<br>Others: reserved.   |
| 24       | Reserved       | Reserved, the reset value must be maintained.  |
| 23:21    | LPTIMSEL[2:0]  | LPTIM clock source selection<br>Set and cleared by software.<br>000: select APB1 clock<br>001: Select HSI clock<br>010: Select HSE clock<br>011: Select LSI clock<br>100: Select LSE clock<br>101: Select COMP output<br>Others: Not allowed, and no clock will be generated |
| 20:16    | Reserved       | Reserved, the reset value must be maintained.  |
| 15:11    | ADC1MPRE[4:0]  | ADC 1M clock prescaler<br>Set and cleared by software to configure the division factor of ADC 1M clock source.<br>00000: ADC 1M clock source not divided<br>00001: ADC 1M clock source divided by 2  |

| BitField | Name           | Description  |
|----------|----------------|--|
|          |                | 00010: ADC 1M clock source divided by 3<br>...<br>11110: ADC 1M clock source divided by 31<br>11111: ADC 1M clock source divided by 32   |
| 10       | ADC1MSEL       | ADC 1M clock source selection<br>Set and cleared by software.<br>0: HSI oscillator clock selected as the input clock of ADC 1M<br>1: HSE oscillator clock selected as the input clock of ADC 1M<br><i>Note: When switching the ADC 1M clock source, you need to ensure that the HSI clock is turned on</i>   |
| 9        | Reserved       | Reserved, the reset value must be maintained.  |
| 8:4      | ADCPLLPRE[4:0] | ADC PLL divider<br>Set and cleared by software to configure the division factor from the PLL clock to the ADC.<br>0xxxx: ADC PLL clock is disabled<br>10000: PLL clock not divided<br>10001: PLL clock divided by 2<br>10010: PLL clock divided by 3<br>10011: PLL clock divided by 4<br>10100: PLL clock divided by 6<br>10101: PLL clock divided by 8<br>10110: PLL clock divided by 10<br>10111: PLL clock divided by 12<br>11000: PLL clock divided by 16<br>11001: PLL clock divided by 32<br>11010: PLL clock divided by 64<br>11011: PLL clock divided by 128<br>Others: PLL clock divided by 256 |
| 3:0      | ADCHPRE[3:0]   | ADC HCLK prescaler<br>Set and cleared by software to configure the division factor from the HCLK clock to the ADC.<br>0000: HCLK clock divided by 1<br>0001: HCLK clock divided by 2<br>0010: HCLK clock divided by 3<br>0011: HCLK clock divided by 4<br>0100: HCLK clock divided by 6<br>0101: HCLK clock divided by 8<br>0110: HCLK clock divided by 10<br>0111: HCLK clock divided by 12<br>1000: HCLK clock divided by 16<br>Others: HCLK clock divided by 32   |

### 4.3.14 EMC Control Register 3 (RCC\_EMCCTRL)

Address offset: 0x30

Reset value: 0x0000 0000

|          |         |         |         |        |        |        |        |         |         |         |         |         |         |         |         |    |  |    |  |    |  |    |  |    |  |    |  |    |  |   |  |
|----------|---------|---------|---------|--------|--------|--------|--------|---------|---------|---------|---------|---------|---------|---------|---------|----|--|----|--|----|--|----|--|----|--|----|--|----|--|---|--|
| 31       |         |         |         | 24     |        |        |        | 23      |         | 22      |         | 21      |         | 20      |         | 19 |  | 18 |  | 17 |  | 16 |  |    |  |    |  |    |  |   |  |
| Reserved |         |         |         |        |        |        |        | GBRST3  | GBRST2  | GBRST1  | GBRST0  | GBNRST3 | GBNRST2 | GBNRST1 | GBNRST0 |    |  |    |  |    |  |    |  |    |  |    |  |    |  |   |  |
| 15       |         | 14      |         | 13     |        | 12     |        | 11      |         | 10      |         | 9       |         | 8       |         | 7  |  | 6  |  | 5  |  | 4  |  | 3  |  | 2  |  | 1  |  | 0 |  |
| CLPRST3  | CLPRST2 | CLPRST1 | CLPRST0 | GBDET3 | GBDET2 | GBDET1 | GBDET0 | GBNDET3 | GBNDET2 | GBNDET1 | GBNDET0 | CLPDET3 | CLPDET2 | CLPDET1 | CLPDET0 |    |  |    |  |    |  |    |  |    |  |    |  |    |  |   |  |
| rw       |         | rw      |         | rw     |        | rw     |        | rw      |         | rw      |         | rw      |         | rw      |         | rw |  | rw |  | rw |  | rw |  | rw |  | rw |  | rw |  |   |  |

| Bit Field | Name     | Description  |
|-----------|----------|--|
| 31:24     | Reserved | Reserved, the reset value must be maintained.  |
| 23        | GBRST3   | GB3 reset<br>Set and cleared by software. and reset by por_rst_n<br>0: Disable reset request<br>1: Enable reset request  |
| 22        | GBRST2   | GB2 reset<br>Set and cleared by software. and reset by por_rst_n<br>0: Disable reset request<br>1: Enable reset request  |
| 21        | GBRST1   | GB1 reset<br>Set and cleared by software. and reset by por_rst_n<br>0: Disable reset request<br>1: Enable reset request  |
| 20        | GBRST0   | GB0 reset<br>Set and cleared by software. and reset by por_rst_n<br>0: Disable reset request<br>1: Enable reset request  |
| 19        | GBNRST3  | GBN3 reset<br>Set and cleared by software. and reset by por_rst_n<br>0: Disable reset request<br>1: Enable reset request |
| 18        | GBNRST2  | GBN2 reset<br>Set and cleared by software. and reset by por_rst_n<br>0: Disable reset request<br>1: Enable reset request |
| 17        | GBNRST1  | GBN1 reset<br>Set and cleared by software. and reset by por_rst_n<br>0: Disable reset request<br>1: Enable reset request |
| 16        | GBNRST0  | GBN0 reset   |

| Bit Field | Name    | Description  |
|-----------|---------|--|
|           |         | Set and cleared by software. and reset by por_rst_n<br>0: Disable reset request<br>1: Enable reset request                     |
| 15        | CLPRST3 | EMC clamp3 reset<br>Set and cleared by software. and reset by por_rst_n<br>0: Disable reset request<br>1: Enable reset request |
| 14        | CLPRST2 | EMC clamp2 reset<br>Set and cleared by software. and reset by por_rst_n<br>0: Disable reset request<br>1: Enable reset request |
| 13        | CLPRST1 | EMC clamp1 reset<br>Set and cleared by software. and reset by por_rst_n<br>0: Disable reset request<br>1: Enable reset request |
| 12        | CLPRST0 | EMC clamp0 reset<br>Set and cleared by software. and reset by por_rst_n<br>0: Disable reset request<br>1: Enable reset request |
| 11        | GBDET3  | GB3 detection enable<br>Set and cleared by software. and reset by por_rst_n<br>0: Disable detection<br>1: Enable detection     |
| 10        | GBDET2  | GB2 detection enable<br>Set and cleared by software. and reset by por_rst_n<br>0: Disable detection<br>1: Enable detection     |
| 9         | GBDET1  | GB1 detection enable<br>Set and cleared by software. and reset by por_rst_n<br>0: Disable detection<br>1: Enable detection     |
| 8         | GBDET0  | GB0 detection enable<br>Set and cleared by software. and reset by por_rst_n<br>0: Disable detection<br>1: Enable detection     |
| 7         | GBNDET3 | GBN3 detection enable<br>Set and cleared by software. and reset by por_rst_n<br>0: Disable detection<br>1: Enable detection    |
| 6         | GBNDET2 | GBN2 detection enable<br>Set and cleared by software. and reset by por_rst_n   |

| Bit Field | Name    | Description   |
|-----------|---------|---|
|           |         | 0: Disable detection<br>1: Enable detection   |
| 5         | GBNDET1 | GBN1 detection enable<br>Set and cleared by software. and reset by por_rst_n<br>0: Disable detection<br>1: Enable detection       |
| 4         | GBNDET0 | GBN0 detection enable<br>Set and cleared by software. and reset by por_rst_n<br>0: Disable detection<br>1: Enable detection       |
| 3         | CLPDET3 | EMC Clamp3 detection enable<br>Set and cleared by software. and reset by por_rst_n<br>0: Disable detection<br>1: Enable detection |
| 2         | CLPDET2 | EMC Clamp2 detection enable<br>Set and cleared by software. and reset by por_rst_n<br>0: Disable detection<br>1: Enable detection |
| 1         | CLPDET1 | EMC Clamp1 detection enable<br>Set and cleared by software. and reset by por_rst_n<br>0: Disable detection<br>1: Enable detection |
| 0         | CLPDET0 | EMC Clamp0 detection enable<br>Set and cleared by software. and reset by por_rst_n<br>0: Disable detection<br>1: Enable detection |

## 5 GPIO and AFIO

### 5.1 Summary

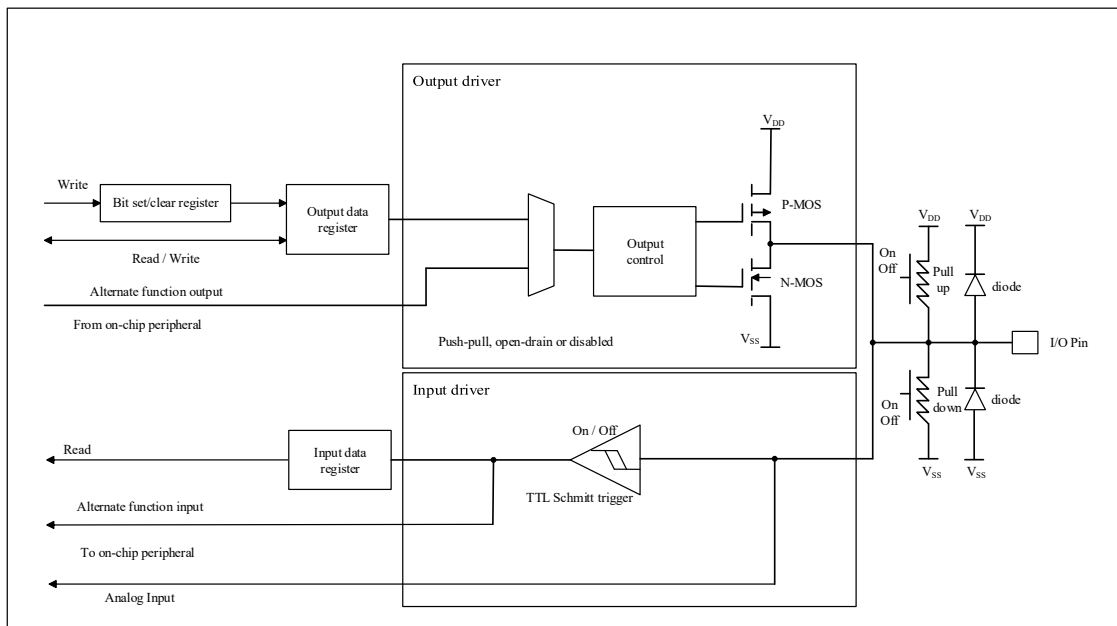
This design supports 40 GPIO, divided into 4 groups (GPIOA/GPIOB/GPIOC/ GPIOF), GPIOA and GPIOB each has 16 pins, GPIOC has 3 pins and GPIOF has 5 pins. GPIO ports share pins with other multiplexed peripherals, allowing users to configure them flexibly according to their needs. Each GPIO pin can be configured by software as output, input or alternate peripheral function ports. Except for pins with analog input function, all GPIO pins have the ability to pass through a large current.

GPIO ports have the following characteristics:

- Each GPIO port can be individually configured into multiple modes by software
  - Input floating
  - Input pull-up
  - Input pull-down
  - Analog function
  - Open drain output and pull-up/pull-down capability
  - Push-pull output and pull-up/pull-down capability
  - Push-pull alternate function and pull-up/pull-down capability
  - Open-drain alternate function and pull-up/pull-down capability
- Individual bit set or bit clear function
- All I/O supports external interrupt function
- All I/O supports low power mode wake-up, rising or falling edge configurable
  - 16 EXTI lines can be used to wake up from SLEEP or STOP mode, and all I/Os can be reused as EXTIs
  - PA0/PC13/PA2 three wake-up I/O can be used for PD mode wake-up, the maximum I/O filter time is 1µs
- Supports software remapping I/O alternate function
- Supports GPIO lock mechanism, reset the lock state to clear

Each I/O port bit can be programmed arbitrarily, but I/O port registers must be accessed as 32-bit words (16-bit half-word or 8-bit byte access is not allowed). The following figure shows the basic structure of an I/O port.

Figure 5-1 Basic Structure of I/O Ports



## 5.2 Function Description

### 5.2.1 I/O Mode Configuration

The mode control of I/O is set by the configuration registers GPIOx\_PMODE, GPIOx\_POTYPE and GPIOx\_PUPD (x=A,B,C,F). The configuration in different operation modes is shown in the following table:

Table 5-1 I/O Port Configuration Table

| PMODE[1:0] | POTYPE | PUPD[1:0] |   | I/O Configuration                             |
|------------|--------|-----------|---|---|
| 01         | 0      | 0         | 0 | General-purpose output push-pull              |
|            | 0      | 0         | 1 | General-purpose output push-pull + pull-up    |
|            | 0      | 1         | 0 | General-purpose output push-pull + pull-down  |
|            | 0      | 1         | 1 | Reserved                                      |
|            | 1      | 0         | 0 | General-purpose output open-drain             |
|            | 1      | 0         | 1 | General-purpose output open-drain + pull-up   |
|            | 1      | 1         | 0 | General-purpose output open-drain + pull-down |
| 10         | 0      | 0         | 0 | Alternate function + push-pull                |
|            | 0      | 0         | 1 | Alternate function + push-pull + pull-up      |
|            | 0      | 1         | 0 | Alternate function + push-pull + pull-down    |
|            | 0      | 1         | 1 | Reserved                                      |
|            | 1      | 0         | 0 | Alternate function open-drain                 |
|            | 1      | 0         | 1 | Alternate function open-drain + pull-up       |
|            | 1      | 1         | 0 | Alternate function open-drain + pull-down     |



| PMODE[1:0] | POTYPE | PUPD[1:0] |   | I/O Configuration |
|------------|--------|-----------|---|-------------------|
|            | 1      | 1         | 1 | Reserved          |
| 00         | x      | 0         | 0 | Input floating    |
|            | x      | 0         | 1 | Input pull-up     |
|            | x      | 1         | 0 | Input pull-down   |
|            | x      | 1         | 1 | Reserved          |
| 11         | x      | 0         | 0 | Analog            |
|            | x      | 0         | 1 | Reserved          |
|            | x      | 1         | 0 |                   |
|            | x      | 1         | 1 |                   |

In addition, the GPIOx\_DS.DSy bit can be used to configure the high/low drive strength, and the GPIOx\_SR.SRy bit can be used to configure the high/low slew rate.

The input and output characteristics of I/O under different configurations are shown in the following table:

**Table 5-2 I/O List of Functional Features of The Pin**

| Feature                            | GPIO Input | GPIO Output   | Analog Function                 | Alternate Function  |
|------------------------------------|------------|---|---------------------------------|---|
| Output buffer                      | Disabled   | Enabled   | Disabled                        | Configuration according to peripheral function  |
| Schmitt trigger                    | Enabled    | Enabled   | Disabled, Output is forced to 0 | Enable  |
| PULL UP/DOWN/FLOATING              | Configured | Configured  | Disabled                        | Configuration according to peripheral function  |
| OPEN DRAIN                         | Disabled   | Can be configured, GPIO output 0 when output data is "0", high resistance of GPIO when "1"      | Disabled                        | Can be configured, GPIO output 0 when output data is "0", high resistance of GPIO when "1"      |
| PUSH PULL MODE                     | Disabled   | Can be configured, GPIO output 0 when output data is "0", GPIO output 1 when output data is "1" | Disabled                        | Can be configured, GPIO output 0 when output data is "0", GPIO output 1 when output data is "1" |
| Input data register (I/O status)   | Readable   | Readable  | Reads out 0                     | Readable  |
| Output data register(Output value) | Invalid    | Readable and written  | Invalid                         | Readable  |

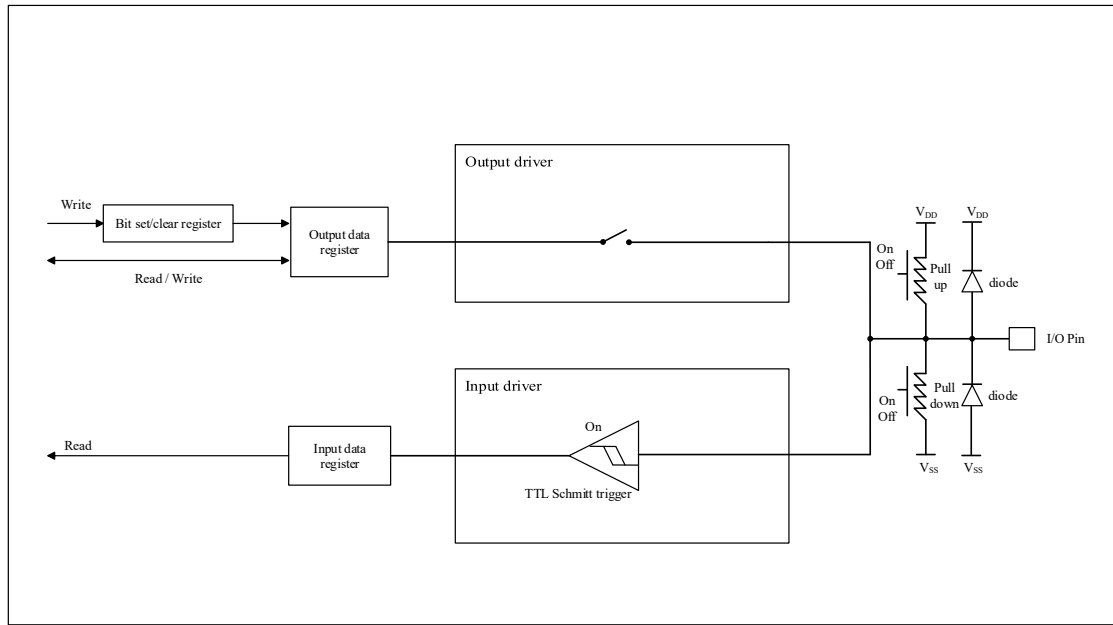
### 5.2.1.1 Input mode

When I/O port is configured as input mode:

- The output buffer is disabled

- The schmitt trigger input is activated.
- Whether the pull-up and pull-down resistors are connected depends on the configuration of the GPIOx\_PUPD register.
- The data appearing on the I/O pins is sampled into the input data register on every APB2 clock
- Read access to the input data register provides the I/O

**Figure 5-2 Input Floating/Pull-up/Pull-down Configuration Mode.**

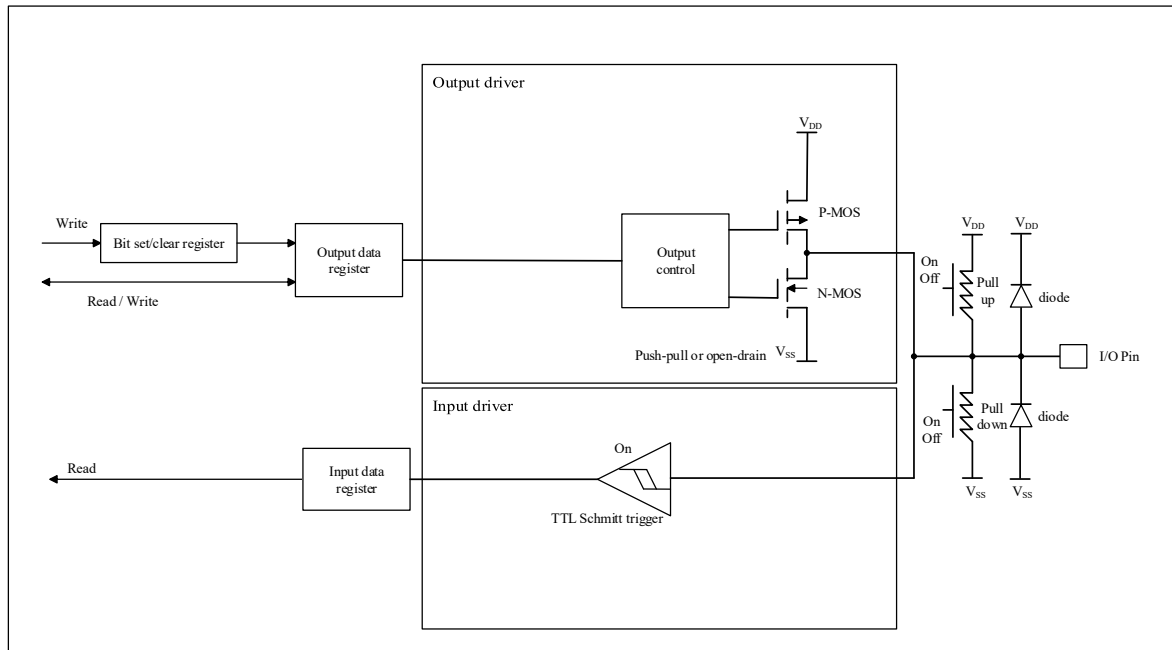


**5.2.1.2 Output mode**

When I/O port is configured as output mode:

- The schmitt trigger input is activated.
- Whether the pull-up and pull-down resistors are connected depends on the configuration of the GPIOx\_PUPD register
- The output buffer is activated
  - Open drain mode: '0' on the output register activates the N-MOS, the pin outputs a low level. while '1' on the output register puts the port in a high resistance state (P-MOS is never activated).
  - Push-pull mode: '0' on the output register activates the N-MOS, the pin outputs a low level. While '1' on the output register activates the P-MOS, the pin outputs a high level.
- The data appearing on the I/O pins is sampled into the input data register every APB2 clock.
- Read access to input data register to get I/O status.
- Read access to the output data register to get the last written value.

Figure 5-3 Output Mode

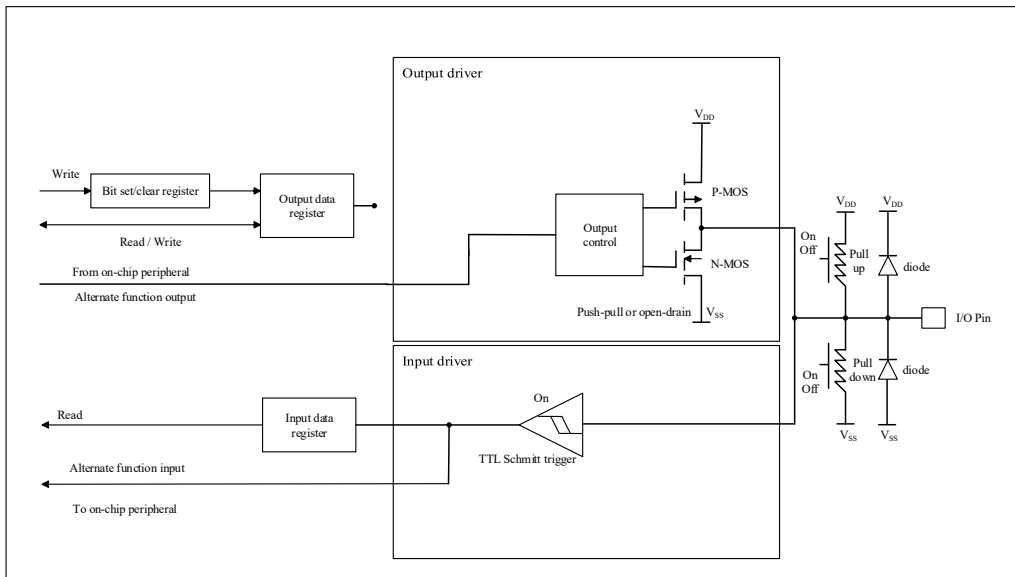


### 5.2.1.3 Alternate function mode

When I/O port is configured as alternate function mode:

- The schmitt trigger input is activated.
- Whether the pull-up and pull-down resistors are connected, depending on the configuration of the GPIOx\_PUPD register.
- In open-drain or push-pull configuration, the output buffer is controlled by the peripheral.
- Signal-driven output buffers foreembedded peripherals.
- At each APB2 clock cycle, the data appearing on the I/O pin is sampled into the input data register.
- Read access to input data register to get I/O status.
- Read access to the output data register to get the last written value.

Figure 5-4 Alternate Function Mode

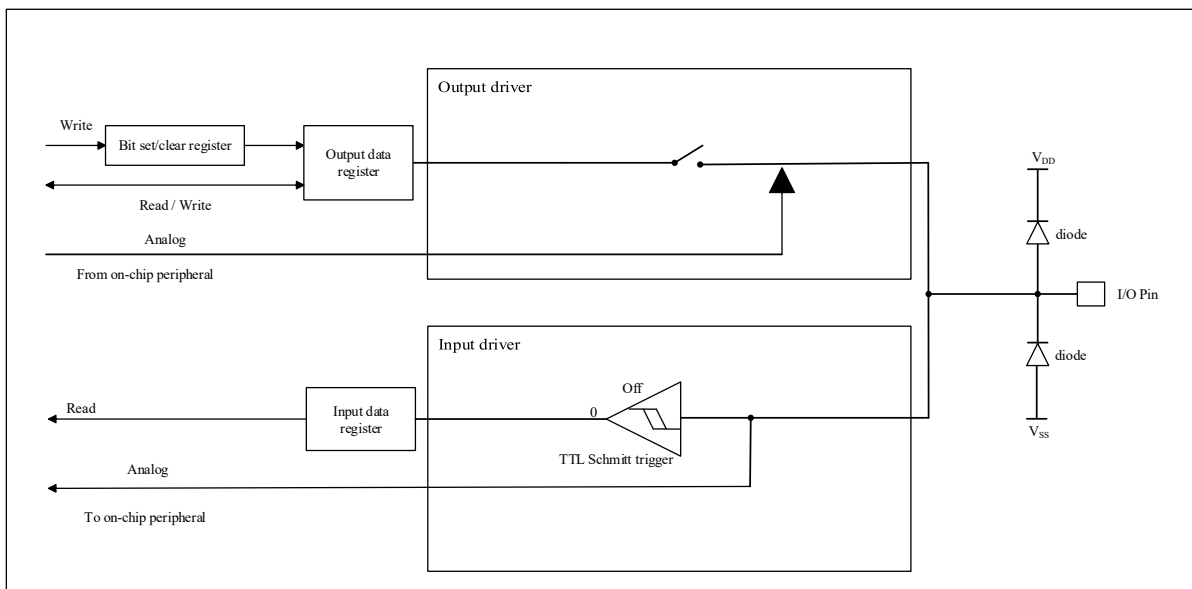


5.2.1.4 Analog function mode

When I/O Port is configured as analog function mode:

- The pull-up and pull-down resistors are disabled.
- Read access to the input data register gets the value “0”.
- The output buffer is disabled.
- Schmitt trigger input is disabled and output value is forced to '0' (achieves zero consumption on each analog I/O pin).

Figure 5-5 Analog Function Mode with High Impedance



### 5.2.2 Status After Reset

During and after reset, the alternate function is not turned on, and the I/O port is configured as analog function mode (GPIOx\_PMODE.PMODEx [1:0] = 11b). However, there are the following exceptions to the signal.

- NRST has no GPIO function by default:
  - NRST pull-up input
- After reset, the SWD pins related to the debugging system are enabled by default:
  - PA14: SWCLK is set to input pull-down mode
  - PA13: SWDIO is set to input pull-up mode
- PA0 and PF0:
  - PA0 and PF0 is default set to input floating mode.
  - PF0 are multiplexed to OSC\_IN.
- PF2/BOOT0:
  - During the chip startup process, PF2 serves as BOOT0 function in the default input pull-down mode. After the chip is initialized, it is used as a general-purpose GPIO and is configured in an analog function mode.

### 5.2.3 Individual Bit Setting and Bit Clearing

By writing '1' to the bit in the set register (GPIOx\_PBSC) and reset register (GPIOx\_PBC), the individual bit operation of the data register (GPIOx\_POD) can be realized, and one or more bits can be set/reset. The bit written with '1' is set or cleared accordingly, and the bit not written with '1' will not be changed. The software does not need to disable interrupts, and is completed in a single APB2 write operation.

### 5.2.4 External Interrupt/Wakeup Line

All ports have external interrupt capability, which can be configured in the EXTI module:

- The ports must be configured as the input mode.
- All ports can be configured for wake-up in SLEEP/STOP mode, and can be configured for rising or falling edge triggering.
- PA0/PC13/PA2, can be used for wake-up in PD mode, with independent wake-up enable, support rising edge / falling edge can be configured, need to configure before entering PD mode.
- General purpose I/O ports are connected to 16 external interrupt/event lines as shown in **Figure 6-2**, configured by registers AFIO\_EXTI\_CFGx.

### 5.2.5 Alternate Function

When I/O ports are configured for alternate function mode. The port bit configuration register (GPIOx\_AFL/GPIOx\_AFH, GPIOx\_PMODE, GPIOx\_POTYPE and GPIOx\_PUPD) must be configured before use, reuse input or output is determined by the peripheral.

#### 5.2.5.1 Software remapping I/O alternate function

To expand the flexibility of alternate peripheral functions under different device packages, some peripheral alternate

functions can be remapped to other pins. Each I/O has up to 16 alternate functions (AF0~AF15). After reset, except for PA13 and PA14, AFSELY is selected as AF15 by default. The I/O alternate function can be remapped by software configuring the corresponding registers (GPIOx\_AFL/ GPIOx\_AFH).

At this time, the alternate functions are no longer mapped to their original pins(For the I/O alternate function of the peripheral, if it is remapped to a different pin, then the input is remapping choose one of multiple, and the output will be connected to the remapped position, and the original position will be disconnected).

### 5.2.5.2 SWD alternate function I/O remapping

**Table 5-3 I/O List of Functional Features of The Pin**

| Alternate Function | I/O  | Remapping |
|--------------------|------|-----------|
| SWDIO              | PA13 | AF0       |
| SWCLK              | PA14 | AF0       |

### 5.2.5.3 TIMx alternate function I/O remapping

#### 5.2.5.4 TIM1 alternate function I/O remapping

**Table 5-4 TIM1 Alternate Function I/O Remapping**

| Alternate Function | I/O  | Remapping |
|--------------------|------|-----------|
| TIM1_ETR           | PA12 | AF2       |
| TIM1_BKIN          | PA2  | AF3       |
|                    | PA6  | AF1       |
|                    | PB12 | AF1       |
| TIM1_CH1           | PA4  | AF3       |
|                    | PA8  | AF2       |
| TIM1_CH2           | PA3  | AF3       |
|                    | PA9  | AF2       |
| TIM1_CH3           | PA5  | AF3       |
|                    | PA10 | AF2       |
| TIM1_CH4           | PA11 | AF2       |
| TIM1_CH1N          | PA7  | AF5       |
|                    | PB13 | AF1       |
| TIM1_CH2N          | PA5  | AF4       |
|                    | PB0  | AF1       |
|                    | PB14 | AF1       |
| TIM1_CH3N          | PB1  | AF1       |
|                    | PB15 | AF1       |

#### 5.2.5.4.1 TIM8 alternate function I/O remapping

Table 5-5 TIM8 Alternate Function I/O Remapping

| Alternate Function | I/O  | Remapping |
|--------------------|------|-----------|
| TIM8_ETR           | PA0  | AF10      |
|                    | PA4  | AF13      |
|                    | PA5  | AF1       |
| TIM8_BKIN          | PA9  | AF1       |
|                    | PA10 | AF1       |
|                    | PB4  | AF1       |
|                    | PB5  | AF1       |
| TIM8_CH1           | PA0  | AF3       |
|                    | PA5  | AF2       |
|                    | PA6  | AF4       |
|                    | PB8  | AF5       |
|                    | PB12 | AF5       |
| TIM8_CH2           | PA1  | AF2       |
|                    | PA7  | AF1       |
|                    | PB9  | AF5       |
|                    | PB13 | AF5       |
| TIM8_CH3           | PA2  | AF2       |
|                    | PB6  | AF2       |
|                    | PB11 | AF5       |
|                    | PB14 | AF5       |
| TIM8_CH4           | PA3  | AF2       |
|                    | PB7  | AF7       |
|                    | PB15 | AF7       |
| TIM8_CH1N          | PA9  | AF5       |
|                    | PB6  | AF5       |
| TIM8_CH2N          | PA8  | AF1       |
|                    | PB7  | AF5       |
| TIM8_CH3N          | PB5  | AF5       |
|                    | PB15 | AF5       |

#### 5.2.5.4.2 TIM3 alternate function I/O remapping

Table 5-6 TIM3 Alternate Function I/O Remapping

| Alternate Function | I/O  | Remapping |
|--------------------|------|-----------|
| TIM3_ETR           | PA1  | AF10      |
|                    | PB3  | AF1       |
|                    | PB10 | AF1       |
| TIM3_CH1           | PA4  | AF2       |

| Alternate Function | I/O | Remapping |
|--------------------|-----|-----------|
|                    | PA6 | AF2       |
|                    | PB4 | AF2       |
| TIM3_CH2           | PA7 | AF2       |
|                    | PB5 | AF2       |
| TIM3_CH3           | PB0 | AF2       |
|                    | PB1 | AF5       |
| TIM3_CH4           | PB1 | AF2       |
|                    | PB2 | AF5       |

### 5.2.5.5 LPTIM alternate function I/O remapping

Table 5-7 LPTIM Alternate Function I/O Remapping

| Alternate Function | I/O | Remapping |
|--------------------|-----|-----------|
| LPTIM_ETR          | PA6 | AF9       |
|                    | PB6 | AF8       |
| LPTIM_IN1          | PA0 | AF7       |
|                    | PB5 | AF8       |
| LPTIM_IN2          | PA1 | AF6       |
|                    | PB7 | AF8       |
| LPTIM_OUT          | PA9 | AF9       |
|                    | PB2 | AF8       |
|                    | PB4 | AF8       |

### 5.2.5.6 USARTx alternate function I/O remapping

### 5.2.5.7 USART1 alternate function I/O remapping

Table 5-8 USART1 Alternate Function I/O Remapping

| Alternate Function | I/O  | Remapping |
|--------------------|------|-----------|
| USART1_CTS         | PA0  | AF1       |
|                    | PA11 | AF4       |
| USART1_RTS         | PA1  | AF1       |
|                    | PA12 | AF4       |
| USART1_TX          | PA2  | AF1       |
|                    | PA9  | AF4       |
|                    | PA13 | AF6       |
|                    | PA14 | AF4       |
|                    | PB6  | AF4       |
|                    | PB9  | AF4       |
| USART1_RX          | PA3  | AF1       |
|                    | PA10 | AF4       |
|                    | PA13 | AF4       |



| Alternate Function | I/O  | Remapping |
|--------------------|------|-----------|
|                    | PA15 | AF4       |
|                    | PB7  | AF4       |
| USART1_CK          | PA4  | AF1       |
|                    | PA8  | AF4       |
|                    | PF1  | AF2       |

#### 5.2.5.7.1 USART2 alternate function I/O remapping

Table 5-9 USART2 Alternate Function I/O Remapping

| Alternate Function | I/O  | Remapping |
|--------------------|------|-----------|
| USART2_CTS         | PA0  | AF4       |
|                    | PA7  | AF10      |
| USART2_RTS         | PA1  | AF4       |
| USART2_TX          | PA2  | AF4       |
|                    | PA9  | AF10      |
|                    | PA14 | AF1       |
| USART2_RX          | PA0  | AF5       |
|                    | PA3  | AF4       |
|                    | PA10 | AF10      |
|                    | PA13 | AF1       |
|                    | PA15 | AF1       |
| USART2_CK          | PA4  | AF4       |
|                    | PB1  | AF3       |
|                    | PF1  | AF5       |

#### 5.2.5.7.2 LPUART alternate function I/O remapping

Table 5-10 LPUART Alternate Function I/O Remapping

| Alternate Function | I/O  | Remapping |
|--------------------|------|-----------|
| LPUART_CTS         | PA6  | AF5       |
|                    | PB7  | AF2       |
|                    | PB13 | AF4       |
| LPUART_RTS         | PA15 | AF6       |
|                    | PB1  | AF4       |
|                    | PB14 | AF4       |
| LPUART_TX          | PA0  | AF6       |
|                    | PA1  | AF5       |
|                    | PA4  | AF10      |
|                    | PA6  | AF6       |
|                    | PB3  | AF5       |
|                    | PB5  | AF4       |
|                    | PB10 | AF4       |

| Alternate Function | I/O  | Remapping |
|--------------------|------|-----------|
| LPUART_RX          | PA0  | AF11      |
|                    | PA3  | AF6       |
|                    | PA7  | AF6       |
|                    | PB4  | AF5       |
|                    | PB7  | AF9       |
|                    | PB11 | AF4       |

### 5.2.5.8 I2Cx alternate function I/O remapping

### 5.2.5.9 I2C1 alternate function I/O remapping

Table 5-11 I<sup>2</sup>C1 Alternate Function I/O Remapping

| Alternate Function | I/O  | Remapping |
|--------------------|------|-----------|
| I2C1_SCL           | PA4  | AF7       |
|                    | PA9  | AF6       |
|                    | PB6  | AF6       |
|                    | PB8  | AF6       |
|                    | PB10 | AF6       |
|                    | PF1  | AF1       |
|                    | PF6  | AF1       |
| I2C1_SDA           | PA10 | AF6       |
|                    | PA13 | AF7       |
|                    | PB7  | AF6       |
|                    | PB9  | AF6       |
|                    | PB11 | AF6       |
|                    | PF0  | AF1       |
|                    | PF7  | AF1       |
| I2C1_SMBA          | PA1  | AF7       |
|                    | PA14 | AF7       |
|                    | PB2  | AF6       |
|                    | PB5  | AF6       |

### 5.2.5.9.1 I2C2 alternate function I/O remapping

Table 5-12 I<sup>2</sup>C2 Alternate Function I/O Remapping

| Alternate Function | I/O  | Remapping |
|--------------------|------|-----------|
| I2C2_SCL           | PA6  | AF7       |
|                    | PA9  | AF7       |
|                    | PA11 | AF7       |
|                    | PB10 | AF7       |
|                    | PB13 | AF7       |
|                    | PF6  | AF0       |

| Alternate Function | I/O  | Remapping |
|--------------------|------|-----------|
| I2C2_SDA           | PA7  | AF7       |
|                    | PA10 | AF7       |
|                    | PA12 | AF7       |
|                    | PB11 | AF7       |
|                    | PB14 | AF7       |
|                    | PF7  | AF0       |
| I2C2_SMBA          | PB2  | AF7       |

### 5.2.5.9.2 SPIx/I2S alternate function I/O remapping

### 5.2.5.9.3 SPI1/I2S alternate function I/O remapping

Table 5-13 SPI1/I<sup>2</sup>S Alternate Function I/O Remapping

| Alternate Function             | I/O  | Remapping |
|--------------------------------|------|-----------|
| SPI1_I <sup>2</sup> S_NSS_WS   | PA1  | AF0       |
|                                | PA4  | AF0       |
|                                | PA15 | AF0       |
|                                | PB12 | AF0       |
| SPI1_I <sup>2</sup> S_SCLK_CK  | PA0  | AF0       |
|                                | PA5  | AF0       |
|                                | PA13 | AF5       |
|                                | PB3  | AF0       |
|                                | PB13 | AF0       |
| SPI1_I <sup>2</sup> S_MISO_MCK | PA3  | AF0       |
|                                | PA4  | AF5       |
|                                | PA6  | AF0       |
|                                | PA14 | AF5       |
|                                | PB4  | AF0       |
|                                | PB14 | AF0       |
| SPI1_I <sup>2</sup> S_MOSI_SD  | PA2  | AF0       |
|                                | PA5  | AF5       |
|                                | PA7  | AF0       |
|                                | PB1  | AF0       |
|                                | PB5  | AF0       |
|                                | PB10 | AF0       |
|                                | PB15 | AF0       |

#### 5.2.5.9.4 SPI2 alternate function I/O remapping

Table 5-14 SPI2 Alternate Function I/O Remapping

| Alternate Function | I/O  | Remapping |
|--------------------|------|-----------|
| SPI2_NSS           | PA7  | AF9       |
|                    | PA8  | AF0       |
|                    | PB9  | AF0       |
|                    | PB12 | AF8       |
|                    | PF7  | AF4       |
| SPI2_SCLK          | PA9  | AF0       |
|                    | PB0  | AF0       |
|                    | PB10 | AF2       |
|                    | PB13 | AF8       |
|                    | PF6  | AF4       |
| SPI2_MISO          | PA10 | AF0       |
|                    | PA12 | AF0       |
|                    | PB14 | AF8       |
| SPI2_MOSI          | PA11 | AF0       |
|                    | PB1  | AF8       |
|                    | PB15 | AF8       |

#### 5.2.5.10 COMP alternate function I/O remapping

Table 5-15 COMP Alternate Function I/O Remapping

| Alternate Function | I/O  | Remapping |
|--------------------|------|-----------|
| COMP_OUT           | PA0  | AF8       |
|                    | PA6  | AF8       |
|                    | PA11 | AF8       |
|                    | PA12 | AF8       |

#### 5.2.5.11 BEEPER alternate function I/O remapping

Table 5-16 BEEPER Alternate Function I/O Remapping

| Alternate Function | I/O | Remapping |
|--------------------|-----|-----------|
| BEEPER_OUT         | PA6 | AF11      |
| BEEPER_N_OUT       | PA7 | AF11      |

#### 5.2.5.12 EVENTOUT alternate function I/O remapping

Table 5-17 EVENTOUT Alternate Function I/O Remapping

| Alternate Function | I/O       | Remapping |
|--------------------|-----------|-----------|
| EVENTOUT           | PA1       | AF3       |
|                    | PA6~PA8   | AF3       |
|                    | PA11~PA12 | AF3       |

| Alternate Function | I/O       | Remapping |
|--------------------|-----------|-----------|
|                    | PA15      | AF3       |
|                    | PB0       | AF3       |
|                    | PB3~PB4   | AF3       |
|                    | PB9       | AF3       |
|                    | PB11~PB12 | AF3       |

### 5.2.5.13 RTC alternate function I/O remapping

PC13 can be used for RTC TAMPER1 tamper detection pin, RTC Timestamp, RTC output (RTC alarm, Wakeup event or calibration output (256Hz or 1Hz)).

PA0 can be used for RTC TAMPER2 tamper detection pin.

PA10 or PB15 can be used for RTC REFCLKIN reference clock input pin.

**Table 5-18 RTC Alternate Function I/O Remapping**

| Alternate Function | I/O  | Remapping |
|--------------------|------|-----------|
| RTC_TS             | PC13 | AF1       |
| RTC_TAMP1          | PC13 | AF2       |
| RTC_TAMP2          | PA0  | AF9       |
| RTC_REFIN          | PA10 | AF11      |
|                    | PB15 | AF9       |
| RTC_OUT            | PC13 | AF3       |

### 5.2.5.14 RCC alternate function I/O remapping

**Table 5-19 RCC Alternate Function I/O Remapping**

| Alternate Function | I/O | Remapping |
|--------------------|-----|-----------|
| MCO                | PA8 | AF5       |
|                    | PA9 | AF11      |

### 5.2.5.15 OSC\_IN/OSC\_OUT alternate function I/O remapping

**Table 5-20 OSC\_IN/OSC\_OUT Alternate Function I/O Remapping**

| Alternate Function | I/O | Remapping |
|--------------------|-----|-----------|
| OSC_IN             | PF0 | AF0       |
| OSC_OUT            | PF1 | AF0       |

### 5.2.5.16 Use OSC32\_IN/OSC32\_OUT pins as GPIO ports PC14/PC15

Both pins PC14 and PC15 can be operated in GPIO mode or alternate function mode:

- PC14 and PC15 can be used for GPIO or LSE (OSC32\_IN, OSC32\_OUT) pins.
- Turn on the LSE function by setting the RCC\_LSCTRL.LSEEN and RCC\_LSCTRL.LSEBP bits.

**Table 5-21 OSC32 Alternate Function Remapping**

| PC14 And PC15           | Condition  | PAD Mode Configure                                    |
|-------------------------|--|---|
| GPIO mode               | It can only be used in GPIO mode when the LSE is turned off and the 1.5V power supply is not turned off with not entering the low power mode (PD). | The mode of the GPIO is determined by the application |
| LSE crystal mode        | RCC_LSCTRL.LSEEN bit is enabled, alternate mode is on  | Analog function mode                                  |
| LSE external clock mode | RCC_LSCTRL.LSEEN bit is disabled, RCC_LSCTRL.LSEBP is enabled, alternate mode is enabled   | Input pull-down                                       |

The default is analog function mode; PC14 and PC15 are decided to operate in which mode and I/O function according to RCC\_LSCTRL.LSEEN, RCC\_LSCTRL.LSEBP, chip mode signal, GPIOx\_PMODE, GPIOx\_POTYPE and GPIOx\_PUPD.

#### 5.2.5.17 Remap OSC\_IN/OSC\_OUT alternate function

PF0 and PF1 can be used for GPIO or HSE (OSC\_IN, OSC\_OUT) pins and other analog or digital signal pins.

- Configure the mode of PF0/PF1 by setting registers such as GPIOF\_PMODE, GPIOF\_POTYPE and GPIOF\_PUPD.
- Remap the I/O alternate function of PF0/PF1 by setting the GPIOF\_AFL.AFSEL0 [3:0] bits and GPIOF\_AFL.AFSEL1[3:0] bits.
- Enable the HSE function by setting the RCC\_CTRL.HSEEN bit.

**Table 5-22 OSC Alternate Function Remapping**

| PF0  | Condition  | PAD Mode Configure                                    |
|--|--|---|
| GPIO mode  | Configure entering general purpose output or input mode and GPIOF_PID and GPIOF_POD registers. | The mode of the GPIO is determined by the application |
| HSE crystal mode or other analog alternate mode    | Reset to analog input<br>HSE, OPA alternate mode   | Analog function mode                                  |
| HSE external clock or other digital alternate mode | HSE clock, I <sup>2</sup> C1, USART1/2 alternate mode  | Mode is determined by the application                 |

#### 5.2.5.18 ADC external trigger alternate function remapping

The external trigger source of ADC injection conversion and regular conversion supports remapping, refer to the AFIO\_CFG register.

**Table 5-23 ADC External Trigger Injection Conversion Alternate Function Remapping**

| Alternate Function                        | ADC_ETRI = 0  | ADC_ETRI = 1   |
|---|---|--|
| ADC external trigger injection conversion | ADC external trigger injection conversion is connected to EXTI (0-15), EXTIx can be selected by AFIO_CFG.EXTI_ETRI[3:0] configuration | ADC external trigger injection conversion is connected to TIM8_CH4 |

**Table 5-24 ADC External Trigger Regular Conversion Alternate Function Remapping**

| Alternate Function                        | ADC_ETRR = 0  | ADC_ETRR = 1  |
|---|---|---|
| ADC external trigger injection conversion | ADC external trigger regular conversion is connected to EXTI (0-15), EXTIx can be selected by AFIO_CFG.EXTI_ETRI[3:0] configuration | ADC external trigger regular conversion is connected to TIM8_TRGO |

## 5.2.6 I/O Configuration of Peripherals

**Table 5-25 ADC**

| ADC | PAD Configuration    |
|-----|----------------------|
| ADC | Analog function mode |

**Table 5-26 PVD**

| PVD    | PAD Configuration    |
|--------|----------------------|
| PVD_IN | Analog function mode |

**Table 5-27 TIM1/TIM8**

| TIM Pin     | Configuration                  | PAD Configuration Mode       |
|-------------|--------------------------------|------------------------------|
| TIM1/8_CHx  | Channel x input capture        | Alternate function push-pull |
|             | Output compare channel x       | Alternate function push-pull |
| TIM1/8_CHxN | Complementary output channel x | Alternate function push-pull |
| TIM1/8_BKIN | Brake input                    | Alternate function push-pull |
| TIM1/8_ETR  | External trigger clock input   | Alternate function push-pull |

**Table 5-28 TIM3 and LPTIM**

| TIM3/LPTIM Pin | Configuration                | PAD Configuration Mode       |
|----------------|------------------------------|------------------------------|
| TIM3/LPTIM_CHx | Input capture channel x      | Alternate function push-pull |
|                | Output compare channel x     | Alternate function push-pull |
| TIM3/LPTIM_ETR | External trigger clock input | Alternate function push-pull |

**Table 5-29 USART**

| USART Pin  | Configuration         | PAD Configuration   |
|------------|-----------------------|---|
| USARTx_TX  | full duplex mode      | Alternate function push-pull                                  |
|            | Half duplex mode      | Alternate function open-drain                                 |
| USARTx_RX  | Full duplex mode      | Alternate function push-pull(no pull-down or pull-up/pull-up) |
|            | Half duplex mode      | Unused, can be used as general I/O.                           |
| USARTx_CK  | Synchronous mode      | Alternate function push-pull                                  |
| USARTx_RTS | Hardware flow control | Alternate function push-pull                                  |
| USARTx_CTS | Hardware flow control | Alternate function push-pull(no pull-down or pull-up/pull-up) |

**Table 5-30 LPUART**

| LPUART Pin | Configuration         | PAD Configuration  |
|------------|-----------------------|--|
| LPUART_TX  | Full duplex mode      | Alternate function push-pull                                   |
| LPUART_RX  | Full duplex mode      | Alternate function push-pull(no pull-down or pull-up/pull-up)  |
| LPUART_RTS | Hardware flow control | Alternate function push-pull                                   |
| LPUART_CTS | Hardware flow control | Alternate function push-pull(no pull-down or pull-up /pull-up) |

**Table 5-31 I<sup>2</sup>C**

| I <sup>2</sup> C Pin   | Configuration          | PAD Configuration             |
|------------------------|------------------------|-------------------------------|
| I <sup>2</sup> Cx_SCL  | I <sup>2</sup> C clock | Alternate function open-drain |
| I <sup>2</sup> Cx_SDA  | I <sup>2</sup> C data  | Alternate function open-drain |
| I <sup>2</sup> Cx_SMBA | SMBA data              | Alternate function open-drain |

**Table 5-32 SPI**

| SPI Pin   | Configuration                                | PAD Configuration   |
|-----------|--|---|
| SPIx_SCLK | Master mode                                  | Alternate function push-pull  |
|           | Slave mode                                   | Alternate function push-pull  |
| SPIx_MOSI | Full duplex mode / Master mode               | Alternate function push-pull  |
|           | Full duplex mode / Slave mode                | Alternate function push-pull(no pull-down or pull-up/pull-up)   |
|           | Simple bidirectional data line / Master mode | Alternate function push-pull  |
|           | Simple bidirectional data line / Slave mode  | Unused, can be used as general I/O.   |
| SPIx_MISO | Full duplex mode / Master mode               | Alternate function push-pull(no pull-down or pull-up/pull-up)   |
|           | Full duplex mode / Slave mode                | Alternate function push-pull  |
|           | Simple bidirectional data line / Master mode | Unused, can be used as general I/O.   |
|           | Simple bidirectional data line / Slave mode  | Alternate function push-pull  |
| SPIx_NSS  | Hardware Master/ Slave mode                  | Alternate function push-pull(no pull-down or pull-up/pull-up/pull-down)                                   |
|           | Hardware Master /NSS output enable           | Alternate function push-pull (When acting as the master, NSS can choose idle high impedance or idle as 1) |
|           | Software mode                                | Unused, can be used as general I/O.   |

**Table 5-33 COMP**

| COMP Pin | PAD Configuration            |
|----------|------------------------------|
| COMP_OUT | Alternate function push-pull |
| COMP_IN  | Analog function mode         |



**Table 5-34 BEEPER**

| BEEPER Pin   | PAD Configuration            |
|--------------|------------------------------|
| BEEPER_OUT   | Alternate function push-pull |
| BEEPER_N_OUT | Alternate function push-pull |

**Table 5-35 Other**

| Pin                 | Alternate Function        | PAD Configuration  |
|---------------------|---------------------------|--|
| EVENTOUT            | Event output              | Alternate function push-pull                                 |
| RTC_TAMP1/RTC_TAMP2 | Tamper event input        | Alternate function push-pull<br>Hardware forced pull-up      |
| RTC_TS              | RTC timestamp             | Alternate function push-pull                                 |
| RTC_REFIN           | RTC reference clock input | Alternate function push-pull                                 |
| RTC_OUT             | RTC output                | Alternate function push-pull                                 |
| MCO                 | Clock output              | Alternate function push-pull                                 |
| EXTI input line     | External interrupt input  | Input floating or input with pull-up or input with pull-down |

### 5.2.7 GPIO Locking Mechanism

The locking mechanism is used to freeze the I/O configuration to prevent accidental changes. When a lock (LOCK) procedure is executed on a port bit, the configuration of the port cannot be changed until the next reset, refer to the port configuration lock register GPIOx\_PLOCK.

- Only after the GPIOx\_PLOCK.PLOCKK is operated in the correct sequence w1->w0->w1->r0 (where r0 must be), it will become 1; after that, it will only become 0 after a system reset.
- GPIOx\_PLOCK.PLOCK[15:0] can only be modified when GPIOx\_PLOCK.PLOCKK = 0 (that is, when unlocked).
- GPIOx\_PLOCK.PLOCK is only written simultaneously with non-zero GPIOx\_PLOCK.PLOCK[15:0], the sequence w1->w0->w1->r0 is valid; During the sequence writing process, GPIOx\_PLOCK.PLOCK[15:0] remains unchanged.
- As long as GPIOx\_PLOCK.PLOCKK = 0, the bits of GPIOx\_PMODE / GPIOx\_POTYPE / GPIOx\_PUPD / GPIOx\_AFL / GPIOx\_AFH can be modified, they are not affected by GPIOx\_PLOCK.PLOCK[15:0] configuration.
- GPIOx\_PLOCK.PLOCKK = 1, GPIOx\_PMODE/GPIOx\_POTYPE/GPIOx\_PUPD/GPIOx\_AFL/GPIOx\_AFH are controlled by GPIOx\_PLOCK.PLOCK[15:0]. Corresponding to GPIOx\_PLOCK.PLOCKy (y = 0...15) = 1, it is a lock configuration and cannot be modified; PLOCKy = 0, it can be modified.
- If the lock sequence operation is wrong, then it must be redone (w1-> w0-> w1-> r0) to initiate the lock operation again.

## 5.3 GPIO Registers

These peripheral registers must be operated as 32-bit words.

### 5.3.1 GPIO Register Overview

GPIOA base address: 0x40010800

GPIOB base address: 0x40010C00

GPIOC base address: 0x40011000

GPIOF base address: 0x40011C00

**Table 5-36 GPIO Register Overview**

| Offset | Register     | 31          | 30            | 29       | 28            | 27       | 26            | 25      | 24            | 23      | 22            | 21      | 20            | 19      | 18           | 17     | 16           | 15     | 14           | 13     | 12           | 11       | 10           | 9       | 8            | 7       | 6            | 5        | 4            | 3       | 2            | 1       | 0            |          |      |        |      |        |      |        |      |        |      |        |      |        |      |        |      |        |   |        |   |      |   |      |   |      |   |      |  |      |  |      |  |      |
|--------|--------------|-------------|---------------|----------|---------------|----------|---------------|---------|---------------|---------|---------------|---------|---------------|---------|--------------|--------|--------------|--------|--------------|--------|--------------|----------|--------------|---------|--------------|---------|--------------|----------|--------------|---------|--------------|---------|--------------|----------|------|--------|------|--------|------|--------|------|--------|------|--------|------|--------|------|--------|------|--------|---|--------|---|------|---|------|---|------|---|------|--|------|--|------|--|------|
| 000h   | GPIOx_PMODE  | x=A,B,C,F   | PMODE15 [1:0] |          | PMODE14 [1:0] |          | PMODE13 [1:0] |         | PMODE12 [1:0] |         | PMODE11 [1:0] |         | PMODE10 [1:0] |         | PMODE9 [1:0] |        | PMODE8 [1:0] |        | PMODE7 [1:0] |        | PMODE6 [1:0] |          | PMODE5 [1:0] |         | PMODE4 [1:0] |         | PMODE3 [1:0] |          | PMODE2 [1:0] |         | PMODE1 [1:0] |         | PMODE0 [1:0] |          |      |        |      |        |      |        |      |        |      |        |      |        |      |        |      |        |   |        |   |      |   |      |   |      |   |      |  |      |  |      |  |      |
|        | Reset Value  | x=A         | 1             | 1        | 1             | 0        | 1             | 0       | 1             | 1       | 1             | 1       | 1             | 1       | 1            | 1      | 1            | 1      | 1            | 1      | 1            | 1        | 1            | 1       | 1            | 1       | 1            | 1        | 1            | 1       | 1            | 1       | 1            |          |      |        |      |        |      |        |      |        |      |        |      |        |      |        |      |        |   |        |   |      |   |      |   |      |   |      |  |      |  |      |  |      |
|        |              | x=B         | 1             | 1        | 1             | 1        | 1             | 1       | 1             | 1       | 1             | 1       | 1             | 1       | 1            | 1      | 1            | 1      | 1            | 1      | 1            | 1        | 1            | 1       | 1            | 1       | 1            | 1        | 1            | 1       | 1            | 1       | 1            | 1        |      |        |      |        |      |        |      |        |      |        |      |        |      |        |      |        |   |        |   |      |   |      |   |      |   |      |  |      |  |      |  |      |
|        |              | x=C         | 1             | 1        | 1             | 1        | 1             | 1       | Reserved      |         |               |         |               |         |              |        |              |        |              |        |              |          |              |         |              |         |              |          |              |         |              |         |              |          |      |        |      |        |      |        |      |        |      |        |      |        |      |        |      |        |   |        |   |      |   |      |   |      |   |      |  |      |  |      |  |      |
| x=F    |              | Reserved    |               |          |               |          |               |         |               |         |               |         |               |         |              |        |              | 1      | 1            | 1      | 1            | Reserved |              |         |              | 1       | 1            | 1        | 1            | 1       | 1            |         |              |          |      |        |      |        |      |        |      |        |      |        |      |        |      |        |      |        |   |        |   |      |   |      |   |      |   |      |  |      |  |      |  |      |
| 004h   | GPIOx_POTYPE | x=A,B,C,F   | Reserved      |          |               |          |               |         |               |         |               |         |               |         |              |        |              |        | POT15        |        | POT14        |          | POT13        |         | POT12        |         | POT11        |          | POT10        |         | POT9         |         | POT8         |          | POT7 |        | POT6 |        | POT5 |        | POT4 |        | POT3 |        | POT2 |        | POT1 |        | POT0 |        |   |        |   |      |   |      |   |      |   |      |  |      |  |      |  |      |
|        | Reset Value  | x=A,B       | Reserved      |          |               |          |               |         |               |         |               |         |               |         |              |        |              |        | 0            | 0      | 0            | 0        | 0            | 0       | 0            | 0       | 0            | 0        | 0            | 0       | 0            | 0       | 0            | 0        | 0    | 0      | 0    | 0      | 0    | 0      | 0    | 0      | 0    | 0      | 0    | 0      | 0    | 0      | 0    | 0      | 0 | 0      | 0 |      |   |      |   |      |   |      |  |      |  |      |  |      |
|        |              | x=C         | Reserved      |          |               |          |               |         |               |         |               |         |               |         |              |        |              |        | 0            | 0      | 0            | Reserved |              |         |              |         |              |          |              |         |              |         |              |          |      |        |      |        |      |        |      |        |      |        |      |        |      |        |      |        |   |        |   |      |   |      |   |      |   |      |  |      |  |      |  |      |
|        |              | x=F         | Reserved      |          |               |          |               |         |               |         |               |         |               |         |              |        |              |        |              |        |              |          |              |         | 0            | 0       | Reserved     |          |              |         | 0            | 0       | 0            | 0        |      |        |      |        |      |        |      |        |      |        |      |        |      |        |      |        |   |        |   |      |   |      |   |      |   |      |  |      |  |      |  |      |
| 008h   |              | GPIOx_SR    | x=A,B,C,F     | Reserved |               |          |               |         |               |         |               |         |               |         |              |        |              |        |              | SR15   |              | SR16     |              | SR17    |              | SR18    |              | SR19     |              | SR20    |              | SR21    |              | SR22     |      | SR23   |      | SR24   |      | SR25   |      | SR26   |      | SR27   |      | SR28   |      | SR29   |      | SR30   |   |        |   |      |   |      |   |      |   |      |  |      |  |      |  |      |
|        | Reset Value  | x=A,B       | Reserved      |          |               |          |               |         |               |         |               |         |               |         |              |        |              |        | 1            | 1      | 1            | 1        | 1            | 1       | 1            | 1       | 1            | 1        | 1            | 1       | 1            | 1       | 1            | 1        | 1    | 1      | 1    | 1      | 1    | 1      | 1    | 1      | 1    | 1      | 1    | 1      | 1    | 1      | 1    | 1      | 1 | 1      | 1 |      |   |      |   |      |   |      |  |      |  |      |  |      |
|        |              | x=C         | Reserved      |          |               |          |               |         |               |         |               |         |               |         |              |        |              |        | 1            | 1      | 1            | Reserved |              |         |              |         |              |          |              |         |              |         |              |          |      |        |      |        |      |        |      |        |      |        |      |        |      |        |      |        |   |        |   |      |   |      |   |      |   |      |  |      |  |      |  |      |
|        |              | x=F         | Reserved      |          |               |          |               |         |               |         |               |         |               |         |              |        |              |        |              |        |              |          |              |         | 1            | 1       | Reserved     |          |              |         | 1            | 1       | 1            | 1        |      |        |      |        |      |        |      |        |      |        |      |        |      |        |      |        |   |        |   |      |   |      |   |      |   |      |  |      |  |      |  |      |
| 00Ch   |              | GPIOx_PUPD  | x=A,B,C,F     | PUP D15  |               | PUP D14  |               | PUP D13 |               | PUP D12 |               | PUP D11 |               | PUP D10 |              | PUP D9 |              | PUP D8 |              | PUP D7 |              | PUP D6   |              | PUP D5  |              | PUP D4  |              | PUP D3   |              | PUP D2  |              | PUP D1  |              | PUP D0   |      |        |      |        |      |        |      |        |      |        |      |        |      |        |      |        |   |        |   |      |   |      |   |      |   |      |  |      |  |      |  |      |
|        | Reset Value  | x=A         | 0             | 0        | 1             | 0        | 0             | 0       | 0             | 0       | 0             | 0       | 0             | 0       | 0            | 0      | 0            | 0      | 0            | 0      | 0            | 0        | 0            | 0       | 0            | 0       | 0            | 0        | 0            | 0       | 0            | 0       | 0            | 0        |      |        |      |        |      |        |      |        |      |        |      |        |      |        |      |        |   |        |   |      |   |      |   |      |   |      |  |      |  |      |  |      |
|        |              | x=B         | 0             | 0        | 0             | 0        | 0             | 0       | 0             | 0       | 0             | 0       | 0             | 0       | 0            | 0      | 0            | 0      | 0            | 0      | 0            | 0        | 0            | 0       | 0            | 0       | 0            | 0        | 0            | 0       | 0            | 0       | 0            | 0        | 0    |        |      |        |      |        |      |        |      |        |      |        |      |        |      |        |   |        |   |      |   |      |   |      |   |      |  |      |  |      |  |      |
|        |              | x=C         | 0             | 0        | 0             | 0        | 0             | 0       | Reserved      |         |               |         |               |         |              |        |              |        |              |        |              |          |              |         |              |         |              |          |              |         |              |         |              |          |      |        |      |        |      |        |      |        |      |        |      |        |      |        |      |        |   |        |   |      |   |      |   |      |   |      |  |      |  |      |  |      |
| x=F    |              | Reserved    |               |          |               |          |               |         |               |         |               |         |               |         |              |        |              | 0      | 0            | 0      | 0            | Reserved |              |         |              | 0       | 0            | 0        | 0            | 0       | 0            | 0       | 0            |          |      |        |      |        |      |        |      |        |      |        |      |        |      |        |      |        |   |        |   |      |   |      |   |      |   |      |  |      |  |      |  |      |
| 010h   | GPIOx_PID    | x=A,B,C,F   | Reserved      |          |               |          |               |         |               |         |               |         |               |         |              |        |              |        | PID15        |        | PID14        |          | PID13        |         | PID12        |         | PID11        |          | PID10        |         | PID9         |         | PID8         |          | PID7 |        | PID6 |        | PID5 |        | PID4 |        | PID3 |        | PID2 |        | PID1 |        | PID0 |        |   |        |   |      |   |      |   |      |   |      |  |      |  |      |  |      |
|        | Reset Value  | x=A,B       | Reserved      |          |               |          |               |         |               |         |               |         |               |         |              |        |              |        | 0            | 0      | 0            | 0        | 0            | 0       | 0            | 0       | 0            | 0        | 0            | 0       | 0            | 0       | 0            | 0        | 0    | 0      | 0    | 0      | 0    | 0      | 0    | 0      | 0    | 0      | 0    | 0      | 0    | 0      | 0    | 0      | 0 | 0      | 0 |      |   |      |   |      |   |      |  |      |  |      |  |      |
|        |              | x=C         | Reserved      |          |               |          |               |         |               |         |               |         |               |         |              |        |              |        | 0            | 0      | 0            | Reserved |              |         |              |         |              |          |              |         |              |         |              |          |      |        |      |        |      |        |      |        |      |        |      |        |      |        |      |        |   |        |   |      |   |      |   |      |   |      |  |      |  |      |  |      |
|        |              | x=F         | Reserved      |          |               |          |               |         |               |         |               |         |               |         |              |        |              |        |              |        |              |          |              |         | 0            | 0       | Reserved     |          |              |         | 0            | 0       | 0            | 0        |      |        |      |        |      |        |      |        |      |        |      |        |      |        |      |        |   |        |   |      |   |      |   |      |   |      |  |      |  |      |  |      |
| 014h   |              | GPIOx_POD   | x=A,B,C,F     | Reserved |               |          |               |         |               |         |               |         |               |         |              |        |              |        |              | POD15  |              | POD14    |              | POD13   |              | POD12   |              | POD11    |              | POD10   |              | POD9    |              | POD8     |      | POD7   |      | POD6   |      | POD5   |      | POD4   |      | POD3   |      | POD2   |      | POD1   |      | POD0   |   |        |   |      |   |      |   |      |   |      |  |      |  |      |  |      |
|        | Reset Value  | x=A,B       | Reserved      |          |               |          |               |         |               |         |               |         |               |         |              |        |              |        | 0            | 0      | 0            | 0        | 0            | 0       | 0            | 0       | 0            | 0        | 0            | 0       | 0            | 0       | 0            | 0        | 0    | 0      | 0    | 0      | 0    | 0      | 0    | 0      | 0    | 0      | 0    | 0      | 0    | 0      | 0    | 0      | 0 | 0      | 0 | 0    |   |      |   |      |   |      |  |      |  |      |  |      |
|        |              | x=C         | Reserved      |          |               |          |               |         |               |         |               |         |               |         |              |        |              |        | 0            | 0      | 0            | Reserved |              |         |              |         |              |          |              |         |              |         |              |          |      |        |      |        |      |        |      |        |      |        |      |        |      |        |      |        |   |        |   |      |   |      |   |      |   |      |  |      |  |      |  |      |
|        |              | x=F         | Reserved      |          |               |          |               |         |               |         |               |         |               |         |              |        |              |        |              |        |              |          |              |         | 0            | 0       | Reserved     |          |              |         | 0            | 0       | 0            | 0        |      |        |      |        |      |        |      |        |      |        |      |        |      |        |      |        |   |        |   |      |   |      |   |      |   |      |  |      |  |      |  |      |
| 018h   |              | GPIOx_PBS   | x=A,B,C,F     | PBC15    |               | PBC14    |               | PBC13   |               | PBC12   |               | PBC11   |               | PBC10   |              | PBC9   |              | PBC8   |              | PBC7   |              | PBC6     |              | PBC5    |              | PBC4    |              | PBC3     |              | PBC2    |              | PBC1    |              | PBC0     |      | PBS15  |      | PBS14  |      | PBS13  |      | PBS12  |      | PBS11  |      | PBS10  |      | PBS9   |      | PBS8   |   | PBS7   |   | PBS6 |   | PBS5 |   | PBS4 |   | PBS3 |  | PBS2 |  | PBS1 |  | PBS0 |
|        | Reset Value  | x=A,B       | 0             | 0        | 0             | 0        | 0             | 0       | 0             | 0       | 0             | 0       | 0             | 0       | 0            | 0      | 0            | 0      | 0            | 0      | 0            | 0        | 0            | 0       | 0            | 0       | 0            | 0        | 0            | 0       | 0            | 0       | 0            | 0        | 0    | 0      | 0    | 0      | 0    | 0      | 0    | 0      | 0    | 0      | 0    | 0      | 0    | 0      | 0    | 0      | 0 | 0      | 0 |      |   |      |   |      |   |      |  |      |  |      |  |      |
|        |              | x=C         | 0             | 0        | 0             | Reserved |               |         |               |         |               |         |               |         |              |        |              |        |              |        |              |          |              |         |              | 0       | 0            | 0        | Reserved     |         |              |         |              |          |      |        |      |        |      |        |      |        |      |        |      |        |      |        |      |        |   |        |   |      |   |      |   |      |   |      |  |      |  |      |  |      |
|        |              | x=F         | Reserved      |          |               |          |               |         |               |         |               |         |               |         |              |        |              |        | 0            | 0      | Reserved     |          |              |         | 0            | 0       | 0            | Reserved |              |         |              | 0       | 0            | Reserved |      |        |      | 0      | 0    | 0      | 0    |        |      |        |      |        |      |        |      |        |   |        |   |      |   |      |   |      |   |      |  |      |  |      |  |      |
| 01Ch   |              | GPIOx_PLOCK | x=A,B,C,F     | Reserved |               |          |               |         |               |         |               |         |               |         |              |        |              |        |              | PLOCKK |              | PLOCK15  |              | PLOCK14 |              | PLOCK13 |              | PLOCK12  |              | PLOCK11 |              | PLOCK10 |              | PLOCK9   |      | PLOCK8 |      | PLOCK7 |      | PLOCK6 |      | PLOCK5 |      | PLOCK4 |      | PLOCK3 |      | PLOCK2 |      | PLOCK1 |   | PLOCK0 |   |      |   |      |   |      |   |      |  |      |  |      |  |      |
|        | Reset Value  | x=A,B       | Reserved      |          |               |          |               |         |               |         |               |         |               |         |              |        |              |        | 0            | 0      | 0            | 0        | 0            | 0       | 0            | 0       | 0            | 0        | 0            | 0       | 0            | 0       | 0            | 0        | 0    | 0      | 0    | 0      | 0    | 0      | 0    | 0      | 0    | 0      | 0    | 0      | 0    | 0      | 0    | 0      | 0 | 0      | 0 | 0    | 0 | 0    | 0 | 0    | 0 | 0    |  |      |  |      |  |      |
|        |              | x=C         | Reserved      |          |               |          |               |         |               |         |               |         |               |         |              |        |              |        | 0            | 0      | 0            | 0        | Reserved     |         |              |         |              |          |              |         |              |         |              |          |      |        |      |        |      |        |      |        |      |        |      |        |      |        |      |        |   |        |   |      |   |      |   |      |   |      |  |      |  |      |  |      |

| Offset | Register    | 31        | 30           | 29 | 28 | 27 | 26           | 25 | 24 | 23 | 22           | 21       | 20 | 19 | 18           | 17       | 16 | 15       | 14           | 13    | 12       | 11    | 10           | 9    | 8    | 7    | 6           | 5        | 4        | 3    | 2           | 1    | 0    |   |   |   |   |   |   |   |   |   |   |
|--------|-------------|-----------|--------------|----|----|----|--------------|----|----|----|--------------|----------|----|----|--------------|----------|----|----------|--------------|-------|----------|-------|--------------|------|------|------|-------------|----------|----------|------|-------------|------|------|---|---|---|---|---|---|---|---|---|---|
|        | x=F         | Reserved  |              |    |    |    |              |    |    |    |              |          |    |    |              |          |    | 0        | Reserved     |       |          |       |              |      |      |      | 0           | 0        | Reserved |      | 0           | 0    | 0    |   |   |   |   |   |   |   |   |   |   |
| 020h   | GPIOx_AFL   | x=A,B,C,F | AFSEL7[3:0]  |    |    |    | AFSEL6[3:0]  |    |    |    | AFSEL5[3:0]  |          |    |    | AFSEL4[3:0]  |          |    |          | AFSEL3[3:0]  |       |          |       | AFSEL2[3:0]  |      |      |      | AFSEL1[3:0] |          |          |      | AFSEL0[3:0] |      |      |   |   |   |   |   |   |   |   |   |   |
|        | Reset Value | x=A,B     | 1            | 1  | 1  | 1  | 1            | 1  | 1  | 1  | 1            | 1        | 1  | 1  | 1            | 1        | 1  | 1        | 1            | 1     | 1        | 1     | 1            | 1    | 1    | 1    | 1           | 1        | 1        | 1    | 1           | 1    | 1    | 1 |   |   |   |   |   |   |   |   |   |
|        |             | x=C       | Reserved     |    |    |    |              |    |    |    |              |          |    |    |              |          |    |          |              |       |          |       |              |      |      |      |             |          |          |      |             |      |      |   |   |   |   |   |   |   |   |   |   |
|        |             | x=F       | 1            | 1  | 1  | 1  | 1            | 1  | 1  | 1  | 1            | Reserved |    |    |              |          |    |          |              |       |          |       |              |      |      |      |             | 1        | 1        | 1    | 1           | 1    | 1    | 1 | 1 | 1 | 1 | 1 | 1 | 1 | 1 | 1 | 1 |
| 024h   | GPIOx_AFH   | x=A,B,C,F | AFSEL15[3:0] |    |    |    | AFSEL14[3:0] |    |    |    | AFSEL13[3:0] |          |    |    | AFSEL12[3:0] |          |    |          | AFSEL11[3:0] |       |          |       | AFSEL10[3:0] |      |      |      | AFSEL9[3:0] |          |          |      | AFSEL8[3:0] |      |      |   |   |   |   |   |   |   |   |   |   |
|        | Reset Value | x=A       | 1            | 1  | 1  | 1  | 0            | 0  | 0  | 0  | 0            | 0        | 0  | 0  | 1            | 1        | 1  | 1        | 1            | 1     | 1        | 1     | 1            | 1    | 1    | 1    | 1           | 1        | 1        | 1    | 1           | 1    | 1    | 1 |   |   |   |   |   |   |   |   |   |
|        |             | x=B       | 1            | 1  | 1  | 1  | 1            | 1  | 1  | 1  | 1            | 1        | 1  | 1  | 1            | 1        | 1  | 1        | 1            | 1     | 1        | 1     | 1            | 1    | 1    | 1    | 1           | 1        | 1        | 1    | 1           | 1    | 1    | 1 |   |   |   |   |   |   |   |   |   |
|        |             | x=C       | 1            | 1  | 1  | 1  | 1            | 1  | 1  | 1  | 1            | 1        | 1  | 1  | 1            | Reserved |    |          |              |       |          |       |              |      |      |      |             |          |          |      |             |      |      |   |   |   |   |   |   |   |   |   |   |
|        | x=F         | Reserved  |              |    |    |    |              |    |    |    |              |          |    |    |              |          |    |          |              |       |          |       |              |      |      |      |             |          |          |      |             |      |      |   |   |   |   |   |   |   |   |   |   |
| 028h   | GPIOx_PBC   | x=A,B,C,F | Reserved     |    |    |    |              |    |    |    |              |          |    |    |              |          |    | PBC15    | PBC14        | PBC13 | PBC12    | PBC11 | PBC10        | PBC9 | PBC8 | PBC7 | PBC6        | PBC5     | PBC4     | PBC3 | PBC2        | PBC1 | PBC0 |   |   |   |   |   |   |   |   |   |   |
|        | Reset Value | x=A,B     | Reserved     |    |    |    |              |    |    |    |              |          |    |    |              |          |    | 0        | 0            | 0     | 0        | 0     | 0            | 0    | 0    | 0    | 0           | 0        | 0        | 0    | 0           | 0    | 0    |   |   |   |   |   |   |   |   |   |   |
|        |             | x=C       | Reserved     |    |    |    |              |    |    |    |              |          |    |    |              |          |    | 0        | 0            | 0     | Reserved |       |              |      |      |      |             |          |          |      |             |      |      |   |   |   |   |   |   |   |   |   |   |
|        |             | x=F       | Reserved     |    |    |    |              |    |    |    |              |          |    |    |              |          |    | Reserved |              |       |          |       |              |      |      | 0    | 0           | Reserved |          | 0    | 0           | 0    |      |   |   |   |   |   |   |   |   |   |   |
| 02Ch   | GPIOx_DS    | x=A,B,C,F | Reserved     |    |    |    |              |    |    |    |              |          |    |    |              |          |    | DS15     | DS14         | DS13  | DS12     | DS11  | DS10         | DS9  | DS8  | DS7  | DS6         | DS5      | DS4      | DS3  | DS2         | DS1  | DS0  |   |   |   |   |   |   |   |   |   |   |
|        | Reset Value | x=A,B     | Reserved     |    |    |    |              |    |    |    |              |          |    |    |              |          |    | 0        | 0            | 0     | 0        | 0     | 0            | 0    | 0    | 0    | 0           | 0        | 0        | 0    | 0           | 0    | 0    |   |   |   |   |   |   |   |   |   |   |
|        |             | x=C       | Reserved     |    |    |    |              |    |    |    |              |          |    |    |              |          |    | 0        | 0            | 0     | Reserved |       |              |      |      |      |             |          |          |      |             |      |      |   |   |   |   |   |   |   |   |   |   |
|        |             | x=F       | Reserved     |    |    |    |              |    |    |    |              |          |    |    |              |          |    | Reserved |              |       |          |       |              |      |      | 0    | 0           | Reserved |          | 0    | 0           | 0    |      |   |   |   |   |   |   |   |   |   |   |

### 5.3.2 GPIO Port Mode Description Register (GPIOx\_PMODE)

Offset address : 0x00

Reset value : 0xEBFF FFFF (x=A); 0xFFFF FFFF (x=B); 0xFC00 0000 (x=C); 0x0000 F03F (x=F)

|              |    |              |    |              |    |              |    |              |    |              |    |             |    |             |    |
|--------------|----|--------------|----|--------------|----|--------------|----|--------------|----|--------------|----|-------------|----|-------------|----|
| 31           | 30 | 29           | 28 | 27           | 26 | 25           | 24 | 23           | 22 | 21           | 20 | 19          | 18 | 17          | 16 |
| PMODE15[1:0] |    | PMODE14[1:0] |    | PMODE13[1:0] |    | PMODE12[1:0] |    | PMODE11[1:0] |    | PMODE10[1:0] |    | PMODE9[1:0] |    | PMODE8[1:0] |    |
| rw           |    | rw           |    | rw           |    | rw           |    | rw           |    | rw           |    | rw          |    | rw          |    |
| 15           | 14 | 13           | 12 | 11           | 10 | 9            | 8  | 7            | 6  | 5            | 4  | 3           | 2  | 1           | 0  |
| PMODE7[1:0]  |    | PMODE6[1:0]  |    | PMODE5[1:0]  |    | PMODE4[1:0]  |    | PMODE3[1:0]  |    | PMODE2[1:0]  |    | PMODE1[1:0] |    | PMODE0[1:0] |    |
| rw           |    | rw           |    | rw           |    | rw           |    | rw           |    | rw           |    | rw          |    | rw          |    |

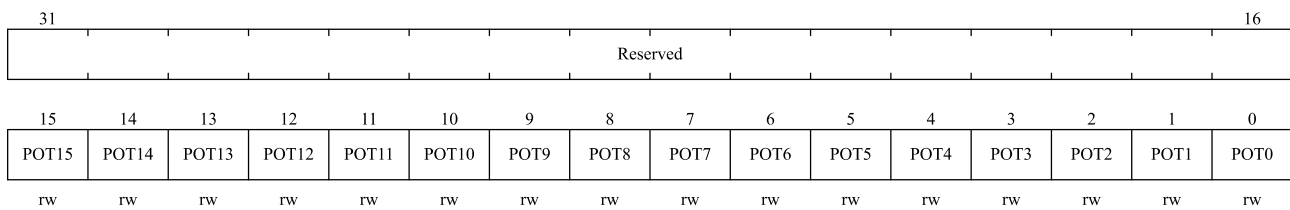
| Bit Field | Name        | Description   |
|-----------|-------------|---|
| 31:30     | PMODEy[1:0] | Mode of port GPIOx (x = A,B,C,F) pin PINy:  |
| 29:28     |             | 00: Input mode  |
| 27:26     |             | 01: General output mode   |
| 25:24     |             | 10: Alternate function mode   |
| 23:22     |             | 11: Analog function mode  |
| 21:20     |             | <i>Note: when x = A,B, y = 0...15;</i>  |
| 19:18     |             | <i>When x = C, y = 13, 14, 15, the remaining bits are reserved, and the reserved bits are read-only;</i>    |
| 17:16     |             | <i>When x = F, y = 0, 1, 2, 6, 7, the remaining bits are reserved, and the reserved bits are read-only.</i> |
| 15:14     |             |   |
| 13:12     |             |   |
| 11:10     |             |   |
| 9:8       |             |   |

| Bit Field                | Name | Description |
|--------------------------|------|-------------|
| 7:6<br>5:4<br>3:2<br>1:0 |      |             |

### 5.3.3 GPIO Port Type Definition (GPIOx\_POTYPE)

Offset address : 0x04

Reset value : 0x0000 0000 (x=A,B,C,F)

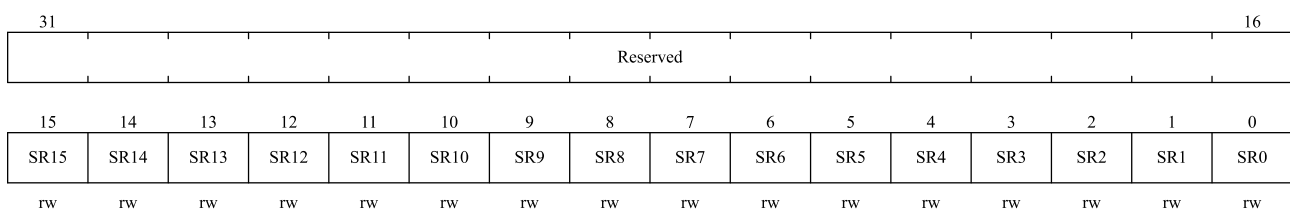


| Bit Field | Name     | Description   |
|-----------|----------|---|
| 31:16     | Reserved | Reserved,the reset value must be maintained   |
| 15:0      | POTy     | Output type of port GPIOx (x = A,B,C,F) pin PINy:<br>0: Output push-pull mode (state after reset)<br>1: Output open-drain mode<br><i>Note: when x = A,B, y = 0...15;</i><br><i>When x = C, y = 13, 14, 15, the remaining bits are reserved, and the reserved bits are read-only;</i><br><i>When x = F, y = 0, 1, 2, 6, 7, the remaining bits are reserved, and the reserved bits are read-only.</i> |

### 5.3.4 GPIO Slew Rate Configuration Register (GPIOx\_SR)

Offset address : 0x08

Reset value : 0x0000 FFFF (x=A, B); 0x0000 E000 (x=C); 0x0000 00C7 (x=F)



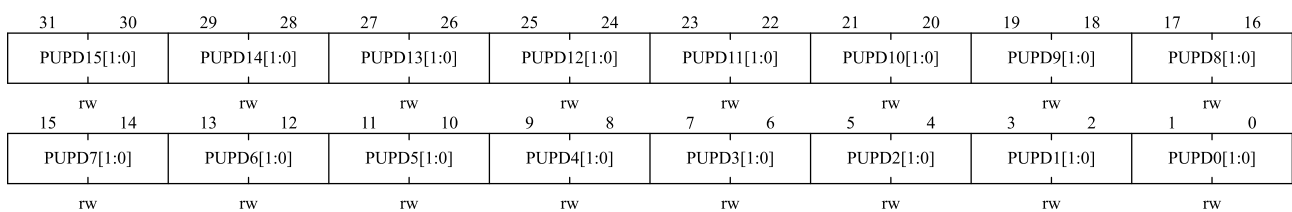
| Bit Field | Name     | Description  |
|-----------|----------|--|
| 31:16     | Reserved | Reserved,the reset value must be maintained  |
| 15:0      | SRy      | Slew rate configuration bits for port GPIOx (x = A,B,C ,F) pin PINy<br>0: Fast slew rate |

| Bit Field | Name | Description   |
|-----------|------|---|
|           |      | 1: Slow slew rate<br><br><i>Note: when <math>x = A, B</math>, <math>y = 0 \dots 15</math>;</i><br><i>When <math>x = C</math>, <math>y = 13, 14, 15</math>, the remaining bits are reserved, and the reserved bits are read-only;</i><br><i>When <math>x = F</math>, <math>y = 0, 1, 2, 6, 7</math>, the remaining bits are reserved, and the reserved bits are read-only.</i> |

### 5.3.5 GPIO Port Pull-Up/Pull-Down Register (GPIOx\_PUPD)

Offset address : 0x0C

Reset value : 0x2400 0000 (x=A); 0x0000 0000 (x=B,C,F)

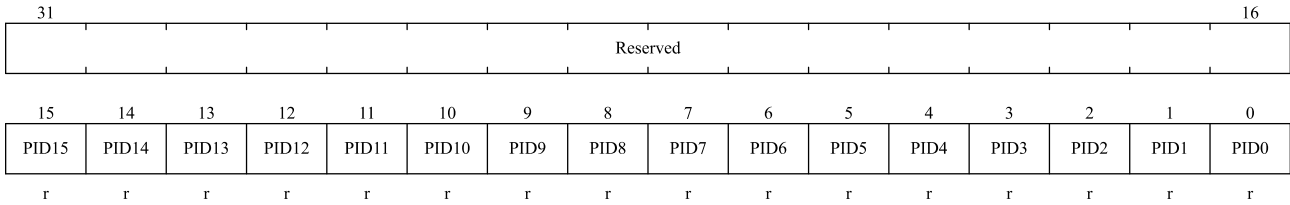


| Bit Field | Name       | Description  |
|-----------|------------|--|
| 31:30     | PUPDy[1:0] | Pull-up and pull-down mode of port GPIOx ( $x = A, B, C, D, F$ ) pin PINy:<br><br>00: no pull-up/pull-down<br>01: Pull up<br>10: Pull down<br>11: Reserved<br><br><i>Note: when <math>x = A, B</math>, <math>y = 0 \dots 15</math>;</i><br><i>When <math>x = C</math>, <math>y = 13, 14, 15</math>, the remaining bits are reserved, and the reserved bits are read-only;</i><br><i>When <math>x = F</math>, <math>y = 0, 1, 2, 6, 7</math>, the remaining bits are reserved, and the reserved bits are read-only.</i> |
| 29:28     |            |  |
| 27:26     |            |  |
| 25:24     |            |  |
| 23:22     |            |  |
| 21:20     |            |  |
| 19:18     |            |  |
| 17:16     |            |  |
| 15:14     |            |  |
| 13:12     |            |  |
| 11:10     |            |  |
| 9:8       |            |  |
| 7:6       |            |  |
| 5:4       |            |  |
| 3:2       |            |  |
| 1:0       |            |  |

### 5.3.6 GPIO Port Input Data Register (GPIOx\_PID)

Offset address : 0x10

Reset value : 0x0000 0000 (x=A,B,C,F)

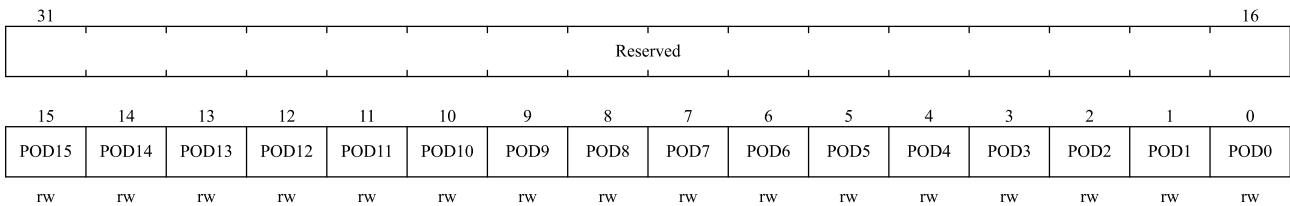


| Bit Field | Name     | Description  |
|-----------|----------|--|
| 31:16     | Reserved | Reserved, the reset value must be maintained   |
| 15:0      | PIDy     | Input data of port GPIOx (x = A,B,C,F) pin PINy<br>These bits are read-only, and the read value is the state of the corresponding I/O port.<br><i>Note: when x = A,B, y = 0...15;</i><br><i>When x = C, y = 13, 14, 15, the remaining bits are reserved, and the reserved bits are read-only;</i><br><i>When x = F, y = 0, 1, 2, 6, 7, the remaining bits are reserved, and the reserved bits are read-only.</i> |

**5.3.7 GPIO Port Output Data Register (GPIOx\_POD)**

Offset address : 0x14

Reset value : 0x0000 0000 (x=A,B,C,F)



| Bit Field | Name     | Description  |
|-----------|----------|--|
| 31:16     | Reserved | Reserved, the reset value must be maintained   |
| 15:0      | PODy     | Output data of port GPIOx (x = A,B,C,F) pin PINy<br>These bits are readable or writable by software, and the corresponding POD bits can be independently set/cleared.<br><i>Note: when x = A,B, y = 0...15;</i><br><i>When x = C, y = 13, 14, 15, the remaining bits are reserved, and the reserved bits are read-only;</i><br><i>When x = F, y = 0, 1, 2, 6, 7, the remaining bits are reserved, and the reserved bits are read-only.</i> |

**5.3.8 GPIO Port Bit Set/Clear Register (GPIOx\_PBSC)**

Offset address : 0x18

Reset value : 0x0000 0000 (x=A,B,C,F)

|       |       |       |       |       |       |      |      |      |      |      |      |      |      |      |      |
|-------|-------|-------|-------|-------|-------|------|------|------|------|------|------|------|------|------|------|
| 31    | 30    | 29    | 28    | 27    | 26    | 25   | 24   | 23   | 22   | 21   | 20   | 19   | 18   | 17   | 16   |
| PBC15 | PBC14 | PBC13 | PBC12 | PBC11 | PBC10 | PBC9 | PBC8 | PBC7 | PBC6 | PBC5 | PBC4 | PBC3 | PBC2 | PBC1 | PBC0 |
| w     | w     | w     | w     | w     | w     | w    | w    | w    | w    | w    | w    | w    | w    | w    | w    |
| 15    | 14    | 13    | 12    | 11    | 10    | 9    | 8    | 7    | 6    | 5    | 4    | 3    | 2    | 1    | 0    |
| PBS15 | PBS14 | PBS13 | PBS12 | PBS11 | PBS10 | PBS9 | PBS8 | PBS7 | PBS6 | PBS5 | PBS4 | PBS3 | PBS2 | PBS1 | PBS0 |
| w     | w     | w     | w     | w     | w     | w    | w    | w    | w    | w    | w    | w    | w    | w    | w    |

| Bit Field | Name | Description  |
|-----------|------|--|
| 31:16     | PBCy | <p>Clear bit y of port GPIOx (x = A,B,C,F)</p> <p>These bits can only be written.</p> <p>0: Does not affect the corresponding PODY bit</p> <p>1: Clear the corresponding PODY bit</p> <p><i>Note: If the corresponding bits of PBSy and PBCy are set at the same time, the PBSy bit operates.</i></p> <p><i>Note: when x = A,B, y = 0...15;</i></p> <p><i>When x = C, y = 13, 14, 15, the remaining bits are reserved, and the reserved bits are read-only;</i></p> <p><i>When x = F, y = 0, 1, 2, 6, 7, the remaining bits are reserved, and the reserved bits are read-only.</i></p> |
| 15:0      | PBSy | <p>Set bit y of port GPIOx (x = A,B,C,F)</p> <p>These bits can only be written.</p> <p>0: Does not affect the corresponding PODY bit</p> <p>1: Set the corresponding PODY bit to 1</p> <p><i>Note: when x = A,B, y = 0...15;</i></p> <p><i>When x = C, y = 13, 14, 15, the remaining bits are reserved, and the reserved bits are read-only;</i></p> <p><i>When x = F, y = 0, 1, 2, 6, 7, the remaining bits are reserved, and the reserved bits are read-only.</i></p>  |

### 5.3.9 GPIO Port Configuration Lock Register (GPIOx\_PLOCK)

Offset address : 0x1C

Reset value : 0x0000 0000 (x=A,B,C,F)

|         |          |         |         |         |         |        |        |        |        |        |        |        |        |        |        |    |
|---------|----------|---------|---------|---------|---------|--------|--------|--------|--------|--------|--------|--------|--------|--------|--------|----|
| 31      | Reserved |         |         |         |         |        |        |        |        |        |        |        |        |        | 17     | 16 |
|         |          |         |         |         |         |        |        |        |        |        |        |        |        |        | PLOCKK |    |
| 15      | 14       | 13      | 12      | 11      | 10      | 9      | 8      | 7      | 6      | 5      | 4      | 3      | 2      | 1      | rw     |    |
| PLOCK15 | PLOCK14  | PLOCK13 | PLOCK12 | PLOCK11 | PLOCK10 | PLOCK9 | PLOCK8 | PLOCK7 | PLOCK6 | PLOCK5 | PLOCK4 | PLOCK3 | PLOCK2 | PLOCK1 | PLOCK0 |    |
| rw      | rw       | rw      | rw      | rw      | rw      | rw     | rw     | rw     | rw     | rw     | rw     | rw     | rw     | rw     | rw     |    |

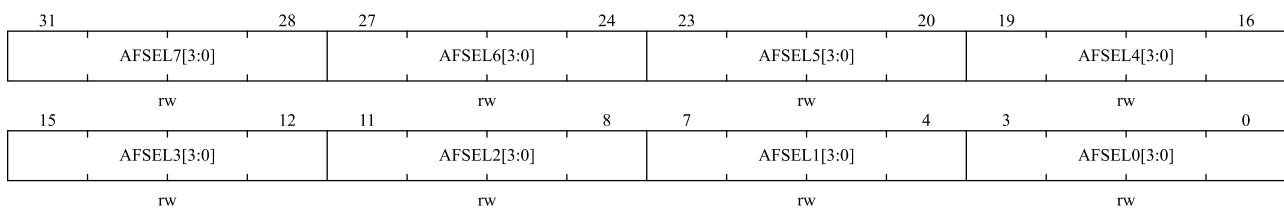
| Bit Field | Name     | Description  |
|-----------|----------|--|
| 31:17     | Reserved | Reserved,the reset value must be maintained  |
| 16        | PLOCKK   | <p>Lock key</p> <p>This bit can be read at any time, it can only be modified by the lock key write</p> |

| Bit Field | Name   | Description   |
|-----------|--------|---|
|           |        | sequence.<br>0: Port configuration lock key is not active<br>1: The port configuration lock key bit is activated, and the GPIOx_PLOCK register is locked before the next system reset.<br>Lock key write sequence:<br>write 1 -> write 0 -> write 1 -> read 0 -> (read 1)<br>The last read 1 can be omitted, but can be used to confirm that the lock key has been activated.<br><i>Note: The value of PLOCK[15:0] cannot be changed while operating the lock key write sequence. Any errors in the operation lock key write sequence will not activate the lock key.</i> |
| 15:0      | PLOCKy | Configuration lock bit for port GPIOx (x = A,B,C,F) pin PINy<br>These bits are readable and writable but can only be written when the PLOCKK bit is 0.<br>0: Do not lock the configuration of the port<br>1: Lock the configuration of the port<br><i>Note: when x = A,B, y = 0...15;</i><br><i>When x = C, y = 13, 14, 15, the remaining bits are reserved, and the reserved bits are read-only;</i><br><i>When x = F, y = 0, 1, 2, 6, 7, the remaining bits are reserved, and the reserved bits are read-only.</i>  |

**5.3.10 GPIO Alternate Function Low Register (GPIOx\_AFL)**

Offset address : 0x20

Reset value : 0xFFFF FFFF (x = A,B); 0x0000 0000 (x = C); 0xFF00 0FFF (x = F)



| Bit Field | Name        | Description  |
|-----------|-------------|--|
| 31:28     | AFSELy[3:0] | Alternate function configuration bits for port GPIOx (x = A,B,C,F) pins PINy (y = 0...7)<br>0000: AF0<br>0001: AF1<br>0010: AF2<br>0011: AF3<br>0100: AF4<br>0101: AF5 |
| 27:24     |             |  |
| 23:20     |             |  |
| 19:16     |             |  |
| 15:12     |             |  |
| 11:8      |             |  |
| 7:4       |             |  |
| 3:0       |             |  |

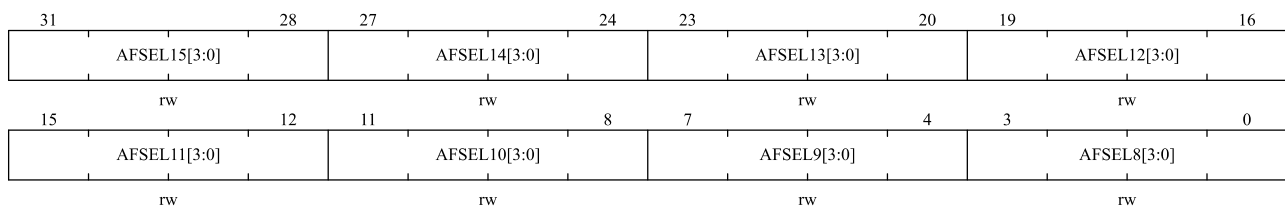


| Bit Field | Name | Description  |
|-----------|------|--|
|           |      | 0110: AF6<br>0111: AF7<br>1000: AF8<br>1001: AF9<br>1010: AF10<br>1011: AF11<br>1100: AF12<br>1101: AF13<br>1110: AF14<br>1111: AF15<br>Note: when $x = A, B, y = 0...7$ ;<br>When $x = C$ , all bits are reserved and reserved bits are read-only. ;<br>When $x = F, y = 0, 1, 2, 6, 7$ , the remaining bits are reserved, and the reserved bits are read-only. |

### 5.3.11 GPIO Alternate Function High Register (GPIOx\_AFH)

Offset address : 0x24

Reset value : 0xF00F FFFF (x = A); 0xFFFF FFFF (x = B); 0xFFFF0 0000 (x = C); 0x0000 0000 (x = F)



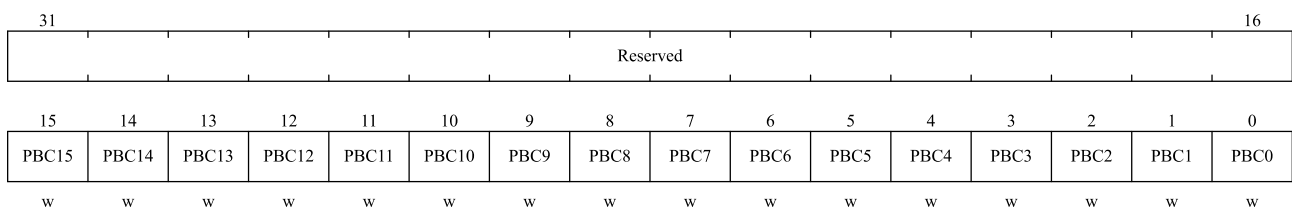
| Bit Field | Name        | Description   |           |
|-----------|-------------|---|-----------|
| 31:28     | AFSELY[3:0] | Alternate Function Configuration Bits for Port GPIOx (x = A,B,C,F) Pins PINy (y = 8...15) |           |
| 27:24     |             |   |           |
| 23:20     |             |   | 0000: AF0 |
| 19:16     |             |   | 0001: AF1 |
| 15:12     |             |   | 0010: AF2 |
| 11:8      |             |   | 0011: AF3 |
| 7:4       |             |   | 0100: AF4 |
| 3:0       |             |   | 0101: AF5 |
|           |             |   | 0110: AF6 |
|           |             |   | 0111: AF7 |
|           |             |   | 1000: AF8 |
|           |             |   | 1001: AF9 |
|           |             |   |           |
|           |             | 1011: AF11  |           |
|           |             | 1100: AF12  |           |

| Bit Field | Name | Description  |
|-----------|------|--|
|           |      | 1101: AF13<br>1110: AF14<br>1111: AF15<br><i>Note: when x = A, B, y = 8...15;</i><br><i>When x = C, y = 13, 14, 15, the remaining bits are reserved, and the reserved bits are read-only;</i><br><i>When x = F, all bits are reserved and reserved bits are read-only.</i> |

### 5.3.12 GPIO Port Bit Clear Register (GPIOx\_PBC)

Offset address : 0x28

Reset value : 0x0000 0000 (x=A,B,C,F)

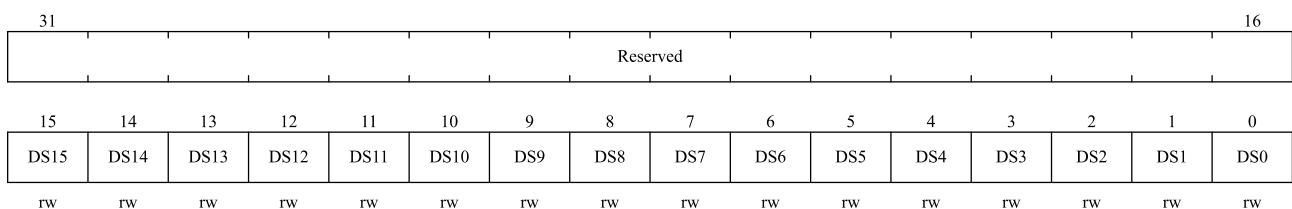


| Bit Field | Name     | Description   |
|-----------|----------|---|
| 31:16     | Reserved | Reserved,the reset value must be maintained   |
| 15:0      | PBCy     | Clear bit y of port GPIOx (x = A,B,C,F)<br>These bits can only be written.<br>0: No effect on the corresponding PODY bit<br>1: Clear the corresponding PODY bit to 0<br><i>Note: when x = A,B, y = 0...15;</i><br><i>When x = C, y = 13, 14, 15, the remaining bits are reserved, and the reserved bits are read-only;</i><br><i>When x = F, y = 0, 1, 2, 6, 7, the remaining bits are reserved, and the reserved bits are read-only.</i> |

### 5.3.13 GPIO Driver Strength Configuration Register (GPIOx\_DS)

Offset address : 0x2C

Reset value : 0x0000 0000 (x=A,B,C,F)



| Bit Field | Name     | Description   |
|-----------|----------|---|
| 31:16     | Reserved | Reserved,the reset value must be maintained   |
| 15:0      | DSy      | Drive capability configuration bits for port GPIOx (x = A,B,C,F) pins PINy<br>0: High drive capability (16mA(5V)/8mA(3.3V)/4mA(1.8V))<br>1: Low drive capability (8mA(5V)/4mA(3.3V)/2mA(1.8V))<br><i>Note: when x = A,B, y = 0...15;</i><br><i>When x = C, y = 13, 14, 15, the remaining bits are reserved, and the reserved bits are read-only;</i><br><i>When x = F, y = 0, 1, 2, 6, 7, the remaining bits are reserved, and the reserved bits are read-only.</i> |

## 5.4 AFIO Registers

### 5.4.1 AFIO Register Overview

AFIO base address: 0x40010000

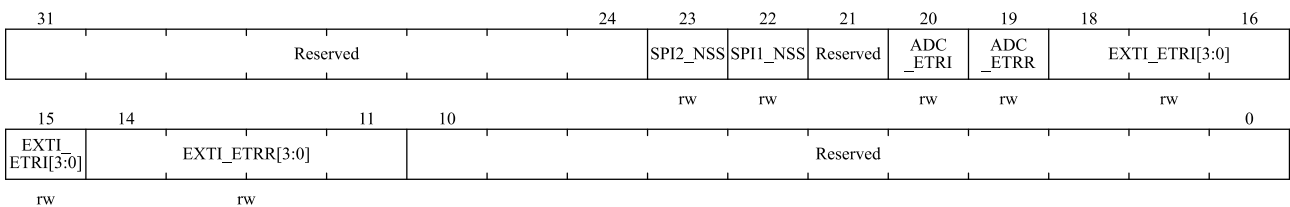
**Table 5-37 AFIO Register Overview**

| Offset | Register       | 31       | 30 | 29 | 28 | 27 | 26 | 25 | 24 | 23 | 22 | 21               | 20       | 19       | 18               | 17       | 16              | 15               | 14 | 13              | 12               | 11 | 10       | 9 | 8 | 7 | 6 | 5 | 4 | 3 | 2 | 1 | 0 |
|--------|----------------|----------|----|----|----|----|----|----|----|----|----|------------------|----------|----------|------------------|----------|-----------------|------------------|----|-----------------|------------------|----|----------|---|---|---|---|---|---|---|---|---|---|
| 000h   | AFIO_CFG       | Reserved |    |    |    |    |    |    |    |    |    | SPI2_NSS         | SPI1_NSS | Reserved | ADC_ETRI         | ADC_ATTR | EXTI_ETRI [3:0] |                  |    | EXTI_ETRR [3:0] |                  |    | Reserved |   |   |   |   |   |   |   |   |   |   |
|        | Reset Value    |          |    |    |    |    |    |    |    |    |    | 0                | 0        |          | 0                | 0        | 0               | 0                | 0  | 0               | 0                | 0  | 0        | 0 |   |   |   |   |   |   |   |   |   |
| 008h   | AFIO_EXTI_CFG1 | Reserved |    |    |    |    |    |    |    |    |    | EXTI3_CFG [3:0]  |          |          | EXTI2_CFG [3:0]  |          |                 | EXTI1_CFG [3:0]  |    |                 | EXTI0_CFG [3:0]  |    |          |   |   |   |   |   |   |   |   |   |   |
|        | Reset Value    |          |    |    |    |    |    |    |    |    |    | 0                | 0        | 0        | 0                | 0        | 0               | 0                | 0  | 0               | 0                | 0  | 0        | 0 | 0 | 0 | 0 | 0 | 0 | 0 | 0 |   |   |
| 00Ch   | AFIO_EXTI_CFG2 | Reserved |    |    |    |    |    |    |    |    |    | EXTI7_CFG [3:0]  |          |          | EXTI6_CFG [3:0]  |          |                 | EXTI5_CFG [3:0]  |    |                 | EXTI4_CFG [3:0]  |    |          |   |   |   |   |   |   |   |   |   |   |
|        | Reset Value    |          |    |    |    |    |    |    |    |    |    | 0                | 0        | 0        | 0                | 0        | 0               | 0                | 0  | 0               | 0                | 0  | 0        | 0 | 0 | 0 | 0 |   |   |   |   |   |   |
| 010h   | AFIO_EXTI_CFG3 | Reserved |    |    |    |    |    |    |    |    |    | EXTI11_CFG [3:0] |          |          | EXTI10_CFG [3:0] |          |                 | EXTI9_CFG [3:0]  |    |                 | EXTI8_CFG [3:0]  |    |          |   |   |   |   |   |   |   |   |   |   |
|        | Reset Value    |          |    |    |    |    |    |    |    |    |    | 0                | 0        | 0        | 0                | 0        | 0               | 0                | 0  | 0               | 0                | 0  | 0        | 0 | 0 | 0 | 0 |   |   |   |   |   |   |
| 014h   | AFIO_EXTI_CFG4 | Reserved |    |    |    |    |    |    |    |    |    | EXTI15_CFG [3:0] |          |          | EXTI14_CFG [3:0] |          |                 | EXTI13_CFG [3:0] |    |                 | EXTI12_CFG [3:0] |    |          |   |   |   |   |   |   |   |   |   |   |
|        | Reset Value    |          |    |    |    |    |    |    |    |    |    | 0                | 0        | 0        | 0                | 0        | 0               | 0                | 0  | 0               | 0                | 0  | 0        | 0 | 0 | 0 | 0 |   |   |   |   |   |   |

### 5.4.2 AFIO Configuration Register (AFIO\_CFG)

Offset address : 0x00

Reset value : 0x0000 0000



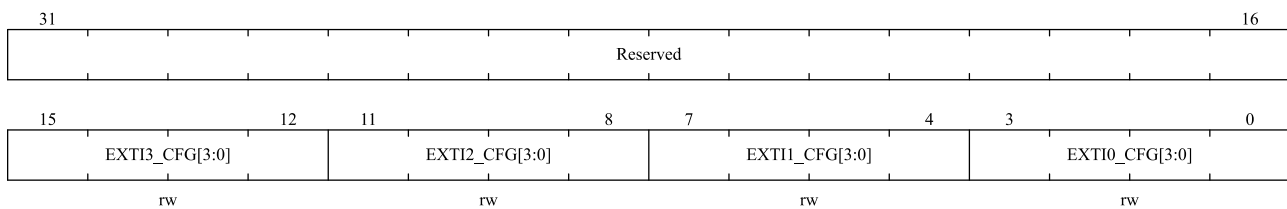
| Bit Field | Name     | Description   |
|-----------|----------|---|
| 31:24     | Reserved | Reserved,the reset value must be maintained                         |
| 23        | SPI2_NSS | NSS mode selection bit of SPI2 (NSS is configured in AFIO push-pull |

| Bit Field | Name           | Description   |
|-----------|----------------|---|
|           |                | mode).<br>0: NSS is high impedance when idle<br>1: NSS is high level when idle  |
| 22        | SPI1_NSS       | NSS mode selection bit of SPI1 (NSS is configured in AFIO push-pull mode).<br>0: NSS is high impedance when idle<br>1: NSS is high level when idle  |
| 21        | Reserved       | Reserved,the reset value must be maintained   |
| 20        | ADC_ETRI       | ADC injection conversion external trigger remapping<br>This bit can be set to '1' or '0' by software. It controls the trigger input connected to the external trigger for ADC injection conversion.<br>0: ADC injection conversion external trigger is connected to EXTI (0-15)<br>1: ADC injection conversion external trigger is connected to TIM8_CH4. |
| 19        | ADC_ETRR       | ADC rugular conversion external trigger remapping<br>This bit can be set to '1' or '0' by software. It controls the trigger input connected to the ADC rugular conversion external trigger.<br>0: ADC rugular conversion external trigger is connected to EXTI (0-15)<br>1: The ADC rugular conversion external trigger is connected to TIM8_TRGO.        |
| 18:15     | EXTI_ETRI[3:0] | Select EXTI Line injection to convert external trigger remapping<br>0000: select EXTI0 injection conversion external trigger<br>0001: Select EXTI1 injection to convert external trigger<br>...<br>1111: Select EXTI15 injection conversion external trigger  |
| 14:11     | EXTI_ETRR[3:0] | Select EXTI Line rugular to convert external trigger remapping<br>0000: Select EXTI0 rugular to convert external trigger<br>0001: Select EXTI1 rugular to convert external trigger<br>...<br>1111: Select EXTI15 rugular to convert external trigger  |
| 10:0      | Reserved       | Reserved,the reset value must be maintained   |

### 5.4.3 AFIO External Interrupt Configuration Register 1 (AFIO\_EXTI\_CFG1)

Offset address : 0x08

Reset value : 0x0000 0000

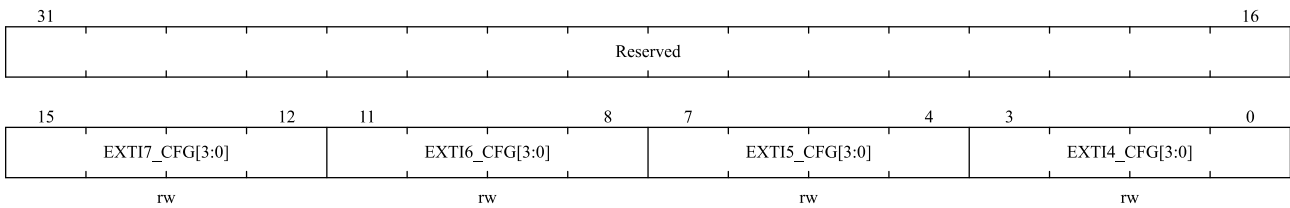


| Bit Field | Name           | Description   |
|-----------|----------------|---|
| 31:30     | Reserved       | Reserved,the reset value must be maintained   |
| 15:0      | EXTIx_CFG[3:0] | <p>EXTIx configuration (x = 0...3)</p> <p>These bits are readable and writable by software and are used to select the input source for the EXTIx external interrupt.</p> <p>EXTI0 configuration:</p> <p>0000: PA0 pin    0001: PB0 pin    0010: reserved<br/>                     0101: PF0 pin    Other: reserved</p> <p>EXTI1 configuration:</p> <p>0000: PA1 pin    0001: PB1 pin    0010: reserved<br/>                     0101: PF1 pin    Other: reserved</p> <p>EXTI2 configuration:</p> <p>0000: PA2 pin    0001: PB2 pin    0010: reserved<br/>                     0101: PF2 pin    Other: reserved</p> <p>EXTI3 configuration:</p> <p>0000: PA3 pin    0001: PB3 pin    0010: reserved<br/>                     0101: reserved    Other: reserved</p> |

**5.4.4 AFIO External Interrupt Configuration Register 2 (AFIO\_EXTI\_CFG2)**

Offset address : 0x0C

Reset value : 0x0000 0000



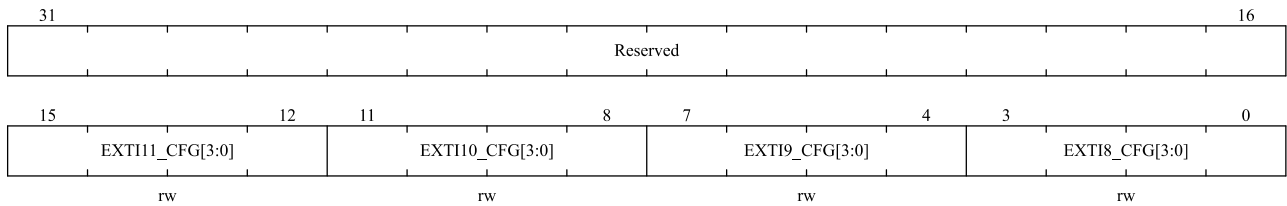
| Bit Field | Name           | Description  |
|-----------|----------------|--|
| 31:30     | Reserved       | Reserved,the reset value must be maintained  |
| 15:0      | EXTIx_CFG[3:0] | <p>EXTIx configuration (x = 4...7)</p> <p>These bits are readable and writable by software and are used to select the input source for the EXTIx external interrupt.</p> <p>EXTI4 configuration:</p> <p>0000: PA4 pin    0001: PB4 pin    0010: reserved<br/>                     0101: reserved    Other: reserved</p> <p>EXTI5 configuration:</p> <p>0000: PA5 pin    0001: PB5 pin    0010: reserved<br/>                     0101: reserved    Other: reserved</p> <p>EXTI6 configuration:</p> <p>0000: PA6 pin    0001: PB6 pin    0010: reserved<br/>                     0101: PF6 pin    Other: reserved</p> |

| Bit Field | Name | Description  |
|-----------|------|--|
|           |      | EXTI7 configuration:<br>0000: PA7 pin    0001: PB7 pin    0010: reserved<br>0101: PF7 pin    Other: reserved |

**5.4.5 AFIO External Interrupt Configuration Register 3 (AFIO\_EXTI\_CFG3)**

Offset address : 0x10

Reset value : 0x0000 0000

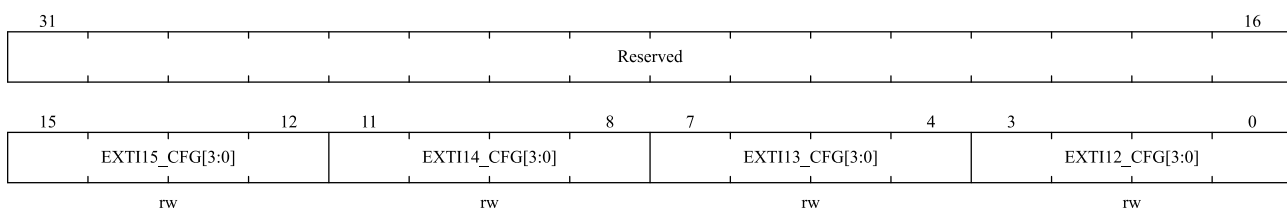


| Bit Field | Name           | Description  |
|-----------|----------------|--|
| 31:30     | Reserved       | Reserved, the reset value must be maintained   |
| 15:0      | EXTIx_CFG[3:0] | EXTIx configuration (x = 8...11)<br>These bits are readable and writable by software and are used to select the input source for the EXTIx external interrupt.<br>EXTI8 configuration:<br>0000: PA8 pin    0001: PB8 pin    0010: reserved<br>0101: reserved    Other: reserved<br>EXTI9 configuration:<br>0000: PA9 pin    0001: PB9 pin    0010: reserved<br>0101: reserved    Other: reserved<br>EXTI10 configuration:<br>0000: PA10 pin    0001: PB10 pin    0010: reserved<br>0101: reserved    Other: reserved<br>EXTI11 configuration:<br>0000: PA11 pin    0001: PB11 pin    0010: reserved<br>0101: reserved    Other: reserved |

**5.4.6 AFIO External Interrupt Configuration Register 4 (AFIO\_EXTI\_CFG4)**

Offset address : 0x14

Reset value : 0x0000 0000



| Bit Field | Name           | Description  |
|-----------|----------------|--|
| 31:30     | Reserved       | Reserved,the reset value must be maintained  |
| 15:0      | EXTIx_CFG[3:0] | <p>EXTIx configuration (x = 12...15)<br/>                     These bits are readable and writable by software and are used to select the input source for the EXTIx external interrupt.</p> <p>EXTI12 configuration:<br/>                     0000: PA12 pin    0001: PB12 pin    0010: reserved<br/>                     0101: reserved    Other: reserved</p> <p>EXTI13 configuration:<br/>                     0000: PA13 pin    0001: PB13 pin    0010: PC13 pin<br/>                     0101: reserved    Other: reserved</p> <p>EXTI14 configuration:<br/>                     0000: PA14 pin    0001: PB14 pin    0010: PC14 pin<br/>                     0101: reserved    Other: reserved</p> <p>EXTI15 configuration:<br/>                     0000: PA15 pin    0001: PB15 pin    0010: PC15 pin<br/>                     0101: reserved    Other: reserved</p> |

## 6 Interrupts and Events

### 6.1 Nested Vectored Interrupt Controller

#### Features

- 32 maskable interrupt channels (not including 16 Cortex<sup>®</sup>-M0 neutral line);
- 4 programmable priorities (using 2 interrupt priorities);
- Low latency exception and interrupt handling;
- Power management control;
- The realization of system control register;

The nested vectored interrupt controller (NVIC) is closely linked to the processor core, enabling low latency interrupt processing and efficient processing of late interrupts. The nested vectored interrupt controller manages interrupts including core exceptions.

#### 6.1.1 SysTick Calibration Value Register

The system tick calibration value is fixed at 6000. When the system tick clock is set to 6MHz (the maximum value of HCLK/8), 1ms time base is generated.

#### 6.1.2 Interrupt and Exception Vectors.

Table 6-1 Vector Table

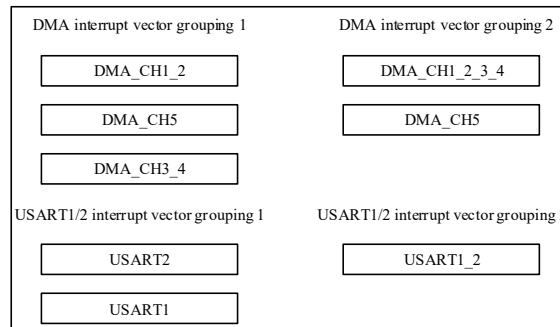
| Position | Priority | Priority Type | Name | Description | Address     |
|----------|----------|---------------|------|-------------|-------------|
| -        | -        | -             | -    | Reserved    | 0x0000 0000 |

| Position | Priority | Priority Type | Name                | Description  | Address     |
|----------|----------|---------------|---------------------|--|-------------|
| -        | -3       | Fixed         | Reset               | Reset  | 0x0000 0004 |
| -        | -2       | Fixed         | NMI                 | Non-maskable interrupt.RCC clock security system (CSS) is connected to the NMI vector. | 0x0000 0008 |
| -        | -1       | Fixed         | HardFault           | All types of errors (fault)  | 0x0000 000C |
| -        | 3        | Settable      | SVCall              | System services invoked by SWI directives  | 0x0000 002C |
| -        | 5        | Settable      | PendSV              | System service requests that can be pending  | 0x0000 0038 |
| -        | 6        | Settable      | SysTick             | System tick timer  | 0x0000 003C |
| 0        | 7        | Settable      | WWDG                | Window watchdog interrupt  | 0x0000 0040 |
| 1        | 8        | Settable      | PVD                 | PVD interrupt connected to EXTI line 16  | 0x0000 0044 |
| 2        | 9        | Settable      | RTC                 | RTC interrupt connected to EXTI lines 17, 19 and 20                                    | 0x0000 0048 |
| 3        | 10       | Settable      | MMU                 | MMU global interrupt   | 0x0000 004C |
| 4        | 11       | Settable      | Flash               | Flash global interrupt   | 0x0000 0050 |
| 5        | 12       | Settable      | RCC                 | RCC global interrupt   | 0x0000 0054 |
| 6        | 13       | Settable      | EXTI0_1             | The EXTI line [1:0] interrupt  | 0x0000 0058 |
| 7        | 14       | Settable      | EXTI2_3             | The EXTI line [3:2] interrupt  | 0x0000 005C |
| 8        | 15       | Settable      | EXTI4_15            | The EXTI line [15:4] interrupt   | 0x0000 0060 |
| 9        | 16       | -             | -                   | Reserved   | 0x0000 0064 |
| 10       | 17       | Settable      | DMA_CH1_2           | DMA channel 1/2 interrupt  | 0x0000 0068 |
| 11       | 18       | Settable      | DMA_CH1_2_3_4       | DMA channel 1/2/3/4 interrupt  | 0x0000 006C |
| 12       | 19       | Settable      | DMA_CH5             | DMA channel 5 interrupt  | 0x0000 0070 |
| 13       | 20       | Settable      | TIM1_BRK_UP_TRG_COM | TIM1 brakes, updates, triggers and communication interrupt                             | 0x0000 0074 |
| 14       | 21       | Settable      | TIM1_CC             | TIM1 capture comparison interrupt  | 0x0000 0078 |
| 15       | 22       | Settable      | DMA_CH3_4           | DMA channel /3/4 interrupt   | 0x0000 007C |
| 16       | 23       | Settable      | TIM3                | TIM3 global interrupt  | 0x0000 0080 |
| 17       | 24       | Settable      | USART2              | USART2 global interrupt  | 0x0000 0084 |
| 18       | 25       | Settable      | TIM8_BRK_UP_TRG_COM | TIM8 brakes, updates, triggers and communication interrupt                             | 0x0000 0088 |
| 19       | 26       | Settable      | TIM8_CC             | TIM8 capture comparison interrupt  | 0x0000 008C |
| 20       | 27       | Settable      | LPTIM/TIM6          | LPTIM (connected to EXTI line 23) /TIM6 global interrupt                               | 0x0000 0090 |
| 21       | 28       | Settable      | ADC                 | ADC global interrupt   | 0x0000 0094 |
| 22       | 29       | Settable      | SPI2                | SPI2 global interrupt  | 0x0000 0098 |
| 23       | 30       | Settable      | I <sup>2</sup> C1   | I <sup>2</sup> C1 global interruption  | 0x0000 009C |
| 24       | 31       | Settable      | I <sup>2</sup> C2   | I <sup>2</sup> C2 global interrupt   | 0x0000 00A0 |



| Position | Priority | Priority Type | Name          | Description   | Address     |
|----------|----------|---------------|---------------|---|-------------|
| 25       | 32       | Settable      | SPI1          | SPI1 global interrupt                               | 0x0000 00A4 |
| 26       | 33       | Settable      | HDIV/SQRT     | Divider/square operator global interrupt            | 0x0000 00A8 |
| 27       | 34       | Settable      | RAMC_ERR      | RAMC_ERR global interrupt                           | 0x0000 00AC |
| 28       | 35       | Settable      | USART1/USART2 | USART1/USART2 global interrupt                      | 0x0000 00B0 |
| 29       | 36       | Settable      | LPUART        | LPUART global interrupt (connected to EXTI line 22) | 0x0000 00B4 |
| 30       | 37       | Settable      | USART1        | USART1 global interrupt                             | 0x0000 00B8 |
| 31       | 38       | Settable      | COMP          | COMP (connected to EXTI line 18)                    | 0x0000 00BC |

DMA and USART1/2 in the interrupt vector scale have several pairs of vectors with repeated functions. The repeated vectors are divided into two groups below:



When using DMA and USART1/2 interrupts, you can choose either group arbitrarily, but only one group at a time.

## 6.2 Extended Interrupt/Event Controller (EXTI)

### 6.2.1 Introduction

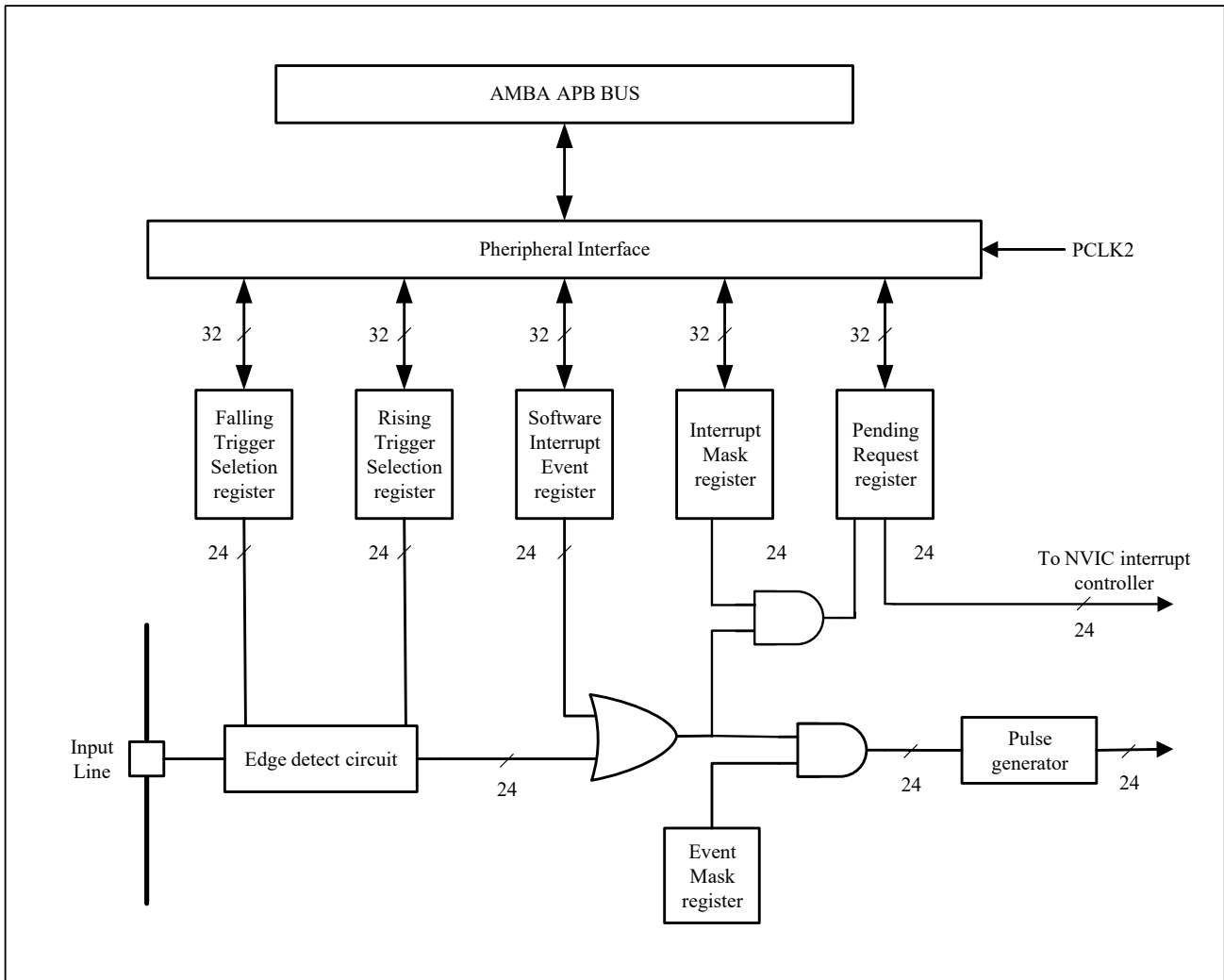
The extended interrupt/event controller contains 24 edge detection circuits that generate interrupt/event triggers. Each input line can be independently configured with pulse or pending input types, and three trigger event types including rising edge, falling edge or double edge, which can also be independently shielded. Interrupt requests that hold the state line in the pending register can be cleared by writing '1' in the corresponding bit of the pending register.

### 6.2.2 Main Features

The main features of EXTI controller are as follows:

- Supports 24 software interrupt/event requests
- Interrupts/events corresponding to each input line can be configured to trigger or mask independently
- Each interrupt line has an independent state bit
- Supports for pulse or pending input types
- 3 trigger events are supported: rising edge, falling edge, and double edge
- Can wake up MCU to exit low power mode

Figure 6-1 External Interrupt/Event Controller Block Diagram



### 6.2.3 Functional Description

The EXTI contains 24 interrupts lines, 16 lines from I/O pins and 8 lines from internal modules. To generate interrupts, the NVIC interrupt channel of the extended interrupt controller must be configured to enable the appropriate interrupt line. Select rising edge, falling edge, or double edge trigger event types by edge trigger configuration registers EXTI\_RT\_CFG and EXTI\_FT\_CFG, and write '1' to the corresponding bit of interrupt masking register EXTI\_IMASK to allow interrupt requests. When a preset edge trigger polarity is detected on the external interrupt line, an interrupt request is generated and the corresponding pending bit is set to '1'. Writing '1' to the corresponding bit of the pending register clears the interrupt request.

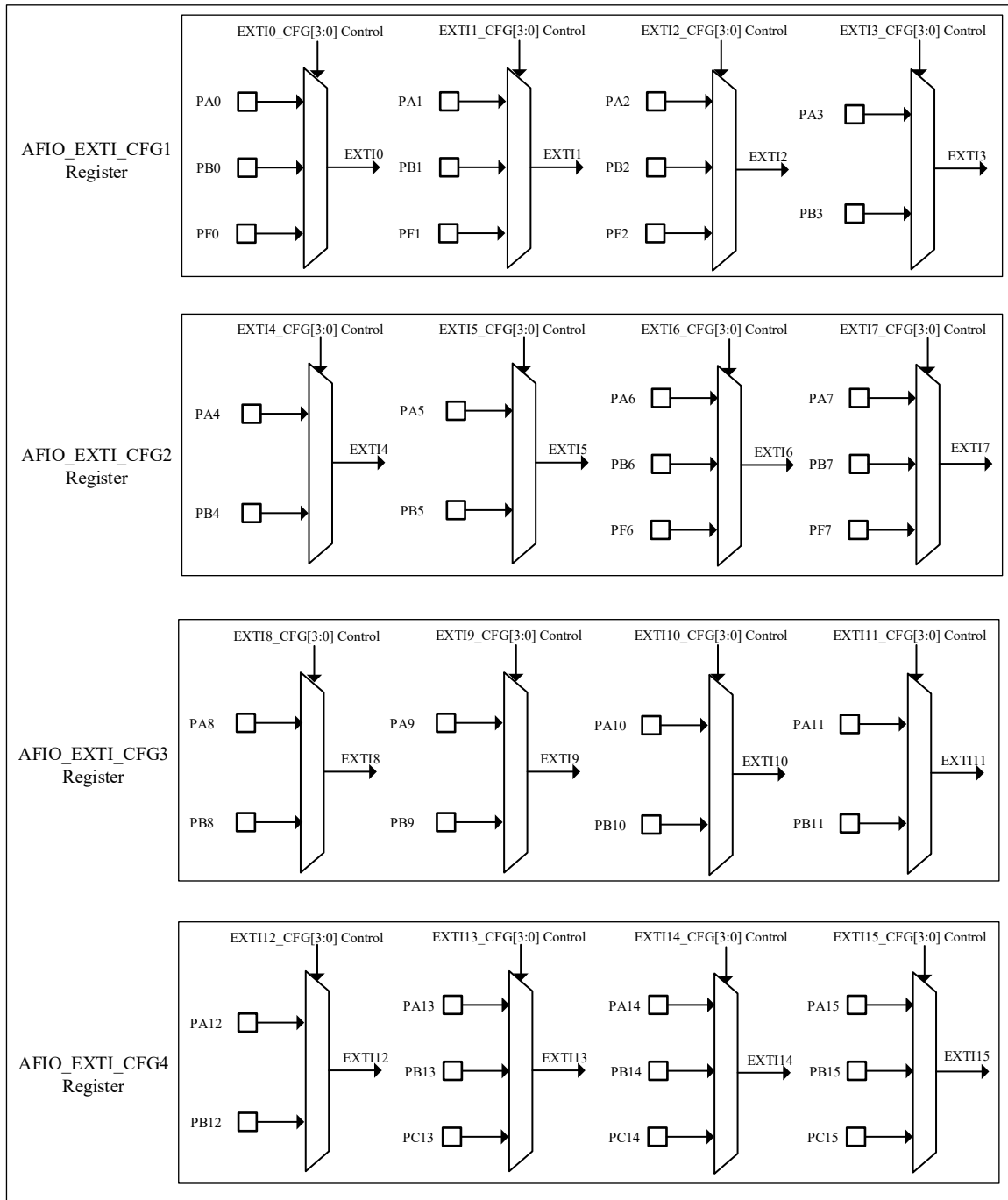
To generate events, the corresponding event line must be configured and enabled. According to the desired edge detection polarity, set up the rise/fall edge trigger configuration register, while writing '1' in the corresponding bit of the event masking register to allow interrupt requests. When a preset edge occurs on an event line, an event request pulse is generated and the corresponding pending bit is not set to '1'.

In addition, interrupt/event requests can also be generated by software by writing a '1' in the software interrupt/event register.

- Hardware interrupt configuration, select and configure 24 lines as interrupt sources as required:
  - Configure the mask bit (EXTI\_IMASK) for 24 interrupt lines.
  - Configure the Trigger Selection bits of the selected interrupt line (EXTI\_RT\_CFG and EXTI\_FT\_CFG);
  - Configure the enable and mask bits of the NVIC interrupt channel corresponding to the external interrupt controller so that the requests in the 24 interrupt lines can be correctly responded to.
- Hardware event configuration: Select 24 lines as event sources as required:
  - Configure the mask bit (EXTI\_EMASK) for 24 event lines.
  - Configure the Trigger Selection bits for the selected event line (EXTI\_RT\_CFG and EXTI\_FT\_CFG).
- Software interrupt/event configuration, select 24 lines as software interrupt/event lines as required:
  - Configure 24 interrupt/event line mask bits (EXTI\_IMASK and EXTI\_EMASK).
  - Configure the request bit of the software interrupt event register (EXTI\_SWIE).

### 6.2.4 EXTI Line Mapping

Figure 6-2 External Interrupt Generic I/O Mapping



To configure external interrupts/events on the GPIO line using AFIO\_EXTI\_CFG1~4, the AFIO clock must be enabled first. General I/O ports are connected to 16 external interrupt/event lines as shown above. The connection mode of the other 8 EXTI lines is as follows:

- EXTI line 16 is connected to the PVD output

- EXTI line 17 is connected to the RTC alarm
- EXTI line 18 is connected to the COMP wake up event
- EXTI line 19 is connected to the RTC tamper for detection or timestamp wake up event
- EXTI line 20 is connected to the RTC wake up event
- EXTI line 21 is reserved
- EXTI line 22 is connected to the LPUART wake up event
- EXTI line 23 is connected to the LPTIM wake up event

### 6.3 EXTI Registers

EXTI base address: 0x40010400

#### 6.3.1 EXTI Register Overview

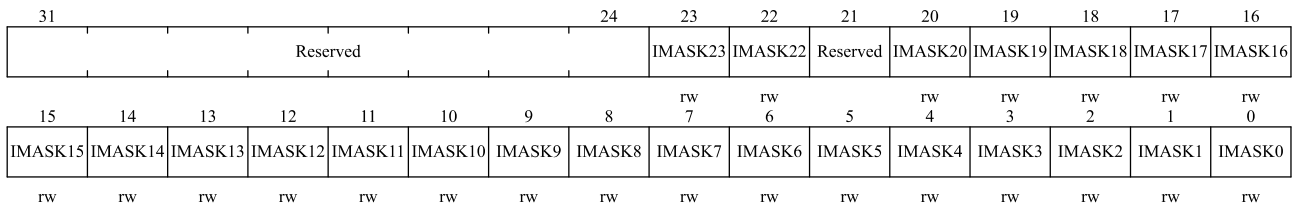
Table 6-2 EXTI Register Overview

| Offset | Register    | 31       | 30 | 29 | 28 | 27 | 26 | 25 | 24 | 23 | 22 | 21       | 20       | 19       | 18 | 17 | 16 | 15 | 14 | 13 | 12 | 11 | 10 | 9        | 8        | 7          | 6        | 5        | 4        | 3        | 2        | 1        | 0        |          |         |         |         |         |         |         |         |         |         |         |
|--------|-------------|----------|----|----|----|----|----|----|----|----|----|----------|----------|----------|----|----|----|----|----|----|----|----|----|----------|----------|------------|----------|----------|----------|----------|----------|----------|----------|----------|---------|---------|---------|---------|---------|---------|---------|---------|---------|---------|
| 000h   | EXTI_IMASK  | Reserved |    |    |    |    |    |    |    |    |    | IMASK23  | IMASK22  | Reserved |    |    |    |    |    |    |    |    |    | IMASK20  | IMASK19  | IMASK18    | IMASK17  | IMASK16  | IMASK15  | IMASK14  | IMASK13  | IMASK12  | IMASK11  | IMASK10  | IMASK9  | IMASK8  | IMASK7  | IMASK6  | IMASK5  | IMASK4  | IMASK3  | IMASK2  | IMASK1  | IMASK0  |
|        | Reset Value | 0        |    |    |    |    |    |    |    |    |    | 0        | 0        | 0        |    |    |    |    |    |    |    |    |    | 0        | 0        | 0          | 0        | 0        | 0        | 0        | 0        | 0        | 0        | 0        | 0       | 0       | 0       | 0       | 0       | 0       | 0       | 0       |         |         |
| 004h   | EXTI_EMASK  | Reserved |    |    |    |    |    |    |    |    |    | EMASK23  | EMASK22  | Reserved |    |    |    |    |    |    |    |    |    | EMASK20  | EMASK19  | EMASK18    | EMASK17  | EMASK16  | EMASK15  | EMASK14  | EMASK13  | EMASK12  | EMASK11  | EMASK10  | EMASK9  | EMASK8  | EMASK7  | EMASK6  | EMASK5  | EMASK4  | EMASK3  | EMASK2  | EMASK1  | EMASK0  |
|        | Reset Value | 0        |    |    |    |    |    |    |    |    |    | 0        | 0        | 0        |    |    |    |    |    |    |    |    |    | 0        | 0        | 0          | 0        | 0        | 0        | 0        | 0        | 0        | 0        | 0        | 0       | 0       | 0       | 0       | 0       | 0       | 0       | 0       | 0       |         |
| 008h   | EXTI_RT_CFG | Reserved |    |    |    |    |    |    |    |    |    | RT_CFG23 | RT_CFG22 | Reserved |    |    |    |    |    |    |    |    |    | RT_CFG20 | RT_CFG19 | RT_CFG18   | RT_CFG17 | RT_CFG16 | RT_CFG15 | RT_CFG14 | RT_CFG13 | RT_CFG12 | RT_CFG11 | RT_CFG10 | RT_CFG9 | RT_CFG8 | RT_CFG7 | RT_CFG6 | RT_CFG5 | RT_CFG4 | RT_CFG3 | RT_CFG2 | RT_CFG1 | RT_CFG0 |
|        | Reset Value | 0        |    |    |    |    |    |    |    |    |    | 0        | 0        | 0        |    |    |    |    |    |    |    |    |    | 0        | 0        | 0          | 0        | 0        | 0        | 0        | 0        | 0        | 0        | 0        | 0       | 0       | 0       | 0       | 0       | 0       | 0       | 0       | 0       | 0       |
| 00Ch   | EXTI_FT_CFG | Reserved |    |    |    |    |    |    |    |    |    | FT_CFG23 | FT_CFG22 | Reserved |    |    |    |    |    |    |    |    |    | FT_CFG20 | FT_CFG19 | FT_CFG18   | FT_CFG17 | FT_CFG16 | FT_CFG15 | FT_CFG14 | FT_CFG13 | FT_CFG12 | FT_CFG11 | FT_CFG10 | FT_CFG9 | FT_CFG8 | FT_CFG7 | FT_CFG6 | FT_CFG5 | FT_CFG4 | FT_CFG3 | FT_CFG2 | FT_CFG1 | FT_CFG0 |
|        | Reset Value | 0        |    |    |    |    |    |    |    |    |    | 0        | 0        | 0        |    |    |    |    |    |    |    |    |    | 0        | 0        | 0          | 0        | 0        | 0        | 0        | 0        | 0        | 0        | 0        | 0       | 0       | 0       | 0       | 0       | 0       | 0       | 0       | 0       | 0       |
| 010h   | EXTI_SWIE   | Reserved |    |    |    |    |    |    |    |    |    | SWIE23   | SWIE22   | Reserved |    |    |    |    |    |    |    |    |    | SWIE20   | SWIE19   | SWIE18     | SWIE17   | SWIE16   | SWIE15   | SWIE14   | SWIE13   | SWIE12   | SWIE11   | SWIE10   | SWIE9   | SWIE8   | SWIE7   | SWIE6   | SWIE5   | SWIE4   | SWIE3   | SWIE2   | SWIE1   | SWIE0   |
|        | Reset Value | 0        |    |    |    |    |    |    |    |    |    | 0        | 0        | 0        |    |    |    |    |    |    |    |    |    | 0        | 0        | 0          | 0        | 0        | 0        | 0        | 0        | 0        | 0        | 0        | 0       | 0       | 0       | 0       | 0       | 0       | 0       | 0       | 0       | 0       |
| 014h   | EXTI_PEND   | Reserved |    |    |    |    |    |    |    |    |    | PEND23   | PEND22   | Reserved |    |    |    |    |    |    |    |    |    | PEND20   | PEND19   | PEND18     | PEND17   | PEND16   | PEND15   | PEND14   | PEND13   | PEND12   | PEND11   | PEND10   | PEND9   | PEND8   | PEND7   | PEND6   | PEND5   | PEND4   | PEND3   | PEND2   | PEND1   | PEND0   |
|        | Reset Value | 0        |    |    |    |    |    |    |    |    |    | 0        | 0        | 0        |    |    |    |    |    |    |    |    |    | 0        | 0        | 0          | 0        | 0        | 0        | 0        | 0        | 0        | 0        | 0        | 0       | 0       | 0       | 0       | 0       | 0       | 0       | 0       | 0       | 0       |
| 018h   | EXTI_TS_SEL | Reserved |    |    |    |    |    |    |    |    |    |          |          |          |    |    |    |    |    |    |    |    |    |          |          | TSSEL[3:0] |          |          |          |          |          |          |          |          |         |         |         |         |         |         |         |         |         |         |
|        | Reset Value | 0        |    |    |    |    |    |    |    |    |    |          |          |          |    |    |    |    |    |    |    |    |    |          |          | 0          | 0        | 0        | 0        |          |          |          |          |          |         |         |         |         |         |         |         |         |         |         |

#### 6.3.2 Interrupt Mask Register(EXTI\_IMASK)

Address offset : 0x00

Reset value : 0x00000000



| Bit Field | Name     | Description                                   |
|-----------|----------|---|
| 31:24     | Reserved | Reserved, the reset value must be maintained. |

|       |          |   |
|-------|----------|---|
| 23:22 | IMASKx   | Interrupt mask on line x. (x is 22,23)<br>0: Mask the interrupt request from line x;<br>1: open the interrupt request from line x         |
| 21    | Reserved | Reserved, the reset value must be maintained.   |
| 20:0  | IMASKx   | Interrupt mask on line x. (x is 0,1,2...19,20)<br>0: Mask the interrupt request from line x;<br>1: open the interrupt request from line x |

**6.3.3 Event Mask Register(EXTI\_EMASK)**

Address offset : 0x04

Reset value : 0x00000000

|          |         |         |         |         |         |        |          |        |        |        |        |        |        |         |         |          |         |         |         |         |         |    |    |
|----------|---------|---------|---------|---------|---------|--------|----------|--------|--------|--------|--------|--------|--------|---------|---------|----------|---------|---------|---------|---------|---------|----|----|
| 31       |         |         |         |         |         |        | 24       |        |        |        |        |        |        | 23      | 22      | 21       | 20      |         | 19      | 18      | 17      | 16 |    |
| Reserved |         |         |         |         |         |        | Reserved |        |        |        |        |        |        | EMASK23 | EMASK22 | Reserved | EMASK20 | EMASK19 | EMASK18 | EMASK17 | EMASK16 |    |    |
| rw       |         |         |         |         |         |        | rw       |        |        |        |        |        |        | rw      | rw      | rw       | rw      | rw      | rw      | rw      | rw      | rw | rw |
| EMASK15  | EMASK14 | EMASK13 | EMASK12 | EMASK11 | EMASK10 | EMASK9 | EMASK8   | EMASK7 | EMASK6 | EMASK5 | EMASK4 | EMASK3 | EMASK2 | EMASK1  | EMASK0  |          |         |         |         |         |         |    |    |
| rw       | rw      | rw      | rw      | rw      | rw      | rw     | rw       | rw     | rw     | rw     | rw     | rw     | rw     | rw      | rw      |          |         |         |         |         |         |    |    |

| Bit Field | Name     | Description   |
|-----------|----------|---|
| 31:24     | Reserved | Reserved, the reset value must be maintained.   |
| 23:22     | EMASKx   | Event masking on line x. (x is 22,23)<br>0: Masking the event request from line x;<br>1: open the event request from line x         |
| 21        | Reserved | Reserved, the reset value must be maintained.   |
| 20:0      | EMASKx   | Event masking on line x. (x is 0,1,2...19,20)<br>0: Masking the event request from line x;<br>1: open the event request from line x |

**6.3.4 Rising Edge Trigger Selection Register(EXTI\_RT\_CFG)**

Address offset : 0x08

Reset value : 0x00000000

|          |          |          |          |          |          |         |          |         |         |         |         |         |         |          |          |          |          |          |          |          |          |    |    |
|----------|----------|----------|----------|----------|----------|---------|----------|---------|---------|---------|---------|---------|---------|----------|----------|----------|----------|----------|----------|----------|----------|----|----|
| 31       |          |          |          |          |          |         | 24       |         |         |         |         |         |         | 23       | 22       | 21       | 20       |          | 19       | 18       | 17       | 16 |    |
| Reserved |          |          |          |          |          |         | Reserved |         |         |         |         |         |         | RT_CFG23 | RT_CFG22 | Reserved | RT_CFG20 | RT_CFG19 | RT_CFG18 | RT_CFG17 | RT_CFG16 |    |    |
| rw       |          |          |          |          |          |         | rw       |         |         |         |         |         |         | rw       | rw       | rw       | rw       | rw       | rw       | rw       | rw       | rw | rw |
| RT_CFG15 | RT_CFG14 | RT_CFG13 | RT_CFG12 | RT_CFG11 | RT_CFG10 | RT_CFG9 | RT_CFG8  | RT_CFG7 | RT_CFG6 | RT_CFG5 | RT_CFG4 | RT_CFG3 | RT_CFG2 | RT_CFG1  | RT_CFG0  |          |          |          |          |          |          |    |    |
| rw       | rw       | rw       | rw       | rw       | rw       | rw      | rw       | rw      | rw      | rw      | rw      | rw      | rw      | rw       | rw       |          |          |          |          |          |          |    |    |

| Bit Field | Name     | Description                                   |
|-----------|----------|---|
| 31:24     | Reserved | Reserved, the reset value must be maintained. |

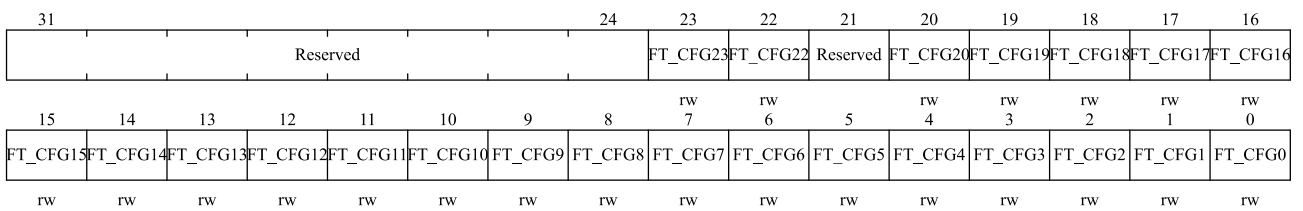


|       |          |  |
|-------|----------|--|
| 23:22 | RT_CFGx  | The rising edge on line x triggers the configuration bit. (x is 22,23)<br>0: Disables rising edge trigger (interrupts and events) on input line x.<br>1: Enable rising edge trigger (interrupts and events) on input line x.         |
| 21    | Reserved | Reserved, the reset value must be maintained.  |
| 20:0  | RT_CFGx  | The rising edge on line x triggers the configuration bit. (x is 0,1,2...19,20)<br>0: Disables rising edge trigger (interrupts and events) on input line x.<br>1: Enable rising edge trigger (interrupts and events) on input line x. |

### 6.3.5 Falling Edge Trigger Selection Register(EXTI\_FT\_CFG)

Address offset : 0x0C

Reset value : 0x00000000

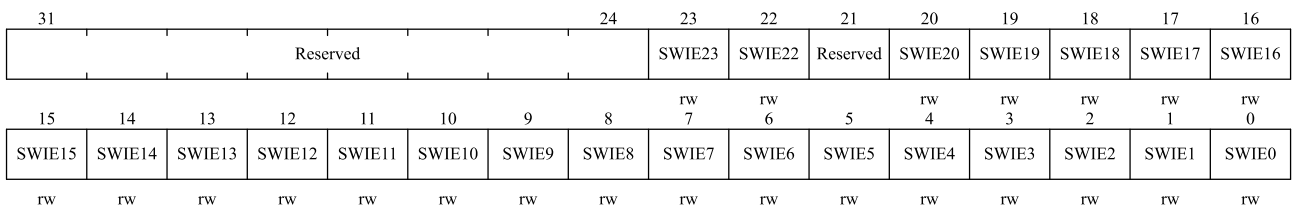


| Bit Field | Name     | Description  |
|-----------|----------|--|
| 31:24     | Reserved | Reserved, the reset value must be maintained.  |
| 23:22     | FT_CFGx  | The falling edge on line x triggers the configuration bit. (x is 22,23)<br>0: Disables falling edge trigger (interrupts and events) on input line x.<br>1: Enable falling edge trigger (interrupts and events) on input line x is allowed.         |
| 21        | Reserved | Reserved, the reset value must be maintained.  |
| 20:0      | FT_CFGx  | The falling edge on line x triggers the configuration bit. (x is 0,1,2...19,20)<br>0: Disables falling edge trigger (interrupts and events) on input line x.<br>1: Enable falling edge trigger (interrupts and events) on input line x is allowed. |

### 6.3.6 Software Interrupt Enable Register(EXTI\_SWIE)

Address offset : 0x10

Reset value : 0x00000000



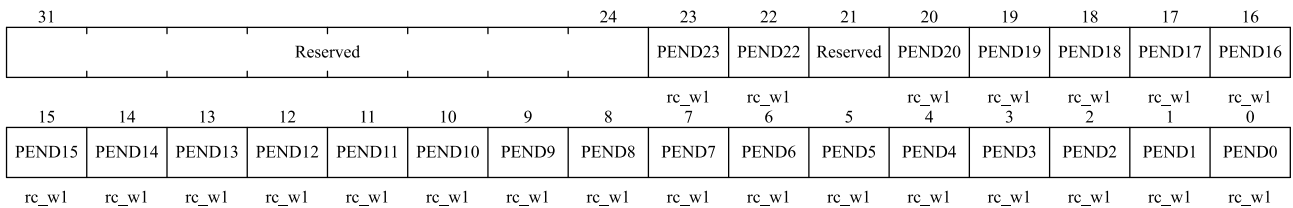
| Bit Field | Name     | Description                                   |
|-----------|----------|---|
| 31:24     | Reserved | Reserved, the reset value must be maintained. |

|       |          |   |
|-------|----------|---|
| 23:22 | SWIEx    | Software interrupt on line x. (x is 22,23)<br>When the bit is '0', writing '1' sets the corresponding pending bit in EXTI_PEND. If this interrupt is allowed in EXTI_IMASK and EXTI_EMASK, an interrupt will be generated.<br><i>Note: This bit can be cleared to '0' by writing '1' to clear the corresponding bit of EXTI_PEND.</i>         |
| 21    | Reserved | Reserved, the reset value must be maintained.   |
| 20:0  | SWIEx    | Software interrupt on line x. (x is 0,1,2...19,20)<br>When the bit is '0', writing '1' sets the corresponding pending bit in EXTI_PEND. If this interrupt is allowed in EXTI_IMASK and EXTI_EMASK, an interrupt will be generated.<br><i>Note: This bit can be cleared to '0' by writing '1' to clear the corresponding bit of EXTI_PEND.</i> |

### 6.3.7 Interrupt Request Pending Register(EXTI\_PEND)

Address offset : 0x14

Reset value : 0x00000000

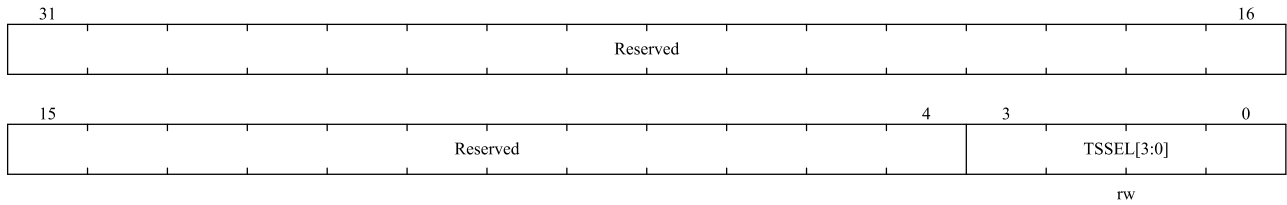


| Bit Field | Name     | Description   |
|-----------|----------|---|
| 31:24     | Reserved | Reserved, the reset value must be maintained.   |
| 23:22     | PENDx    | Hang bit on line x. (x is 22,23)<br>0: No pending request occurred.<br>1: A pending trigger request has occurred.<br>This bit is set to '1' when a selected edge trigger event occurs on the external interrupt line. It can be cleared by writing '1' to the bit, or by changing the polarity of the edge detection.         |
| 21        | Reserved | Reserved, the reset value must be maintained.   |
| 20:0      | PENDx    | Hang bit on line x. (x is 0,1,2...19,20)<br>0: No pending request occurred.<br>1: A pending trigger request has occurred.<br>This bit is set to '1' when a selected edge trigger event occurs on the external interrupt line. It can be cleared by writing '1' to the bit, or by changing the polarity of the edge detection. |

### 6.3.8 RTC Timestamp Trigger Source Selection Register (EXTI\_TS\_SEL)

Address offset : 0x18

Reset value : 0x00000000



| Bit Field | Name       | Description  |
|-----------|------------|--|
| 31:4      | Reserved   | Reserved, the reset value must be maintained.  |
| 3:0       | TSSEL[3:0] | Select external interrupt input as trigger source of timestamp event.<br>0: Select EXTI0 as the trigger source of timestamp event;<br>1: select EXTI1 as the trigger source of timestamp event;<br>.....<br>15: Select EXTI15 as the trigger source of timestamp events. |

## 7 DMA Controller

### 7.1 Introduction

The DMA controller can access totally 5 AHB slaves: Flash, SRAM, ADC, ABP1 and APB2. DMA Controller is controlled by CPU to perform fast data transfer from source to destination. After configuration, data can be transferred without CPU intervention. Thus, CPU can be released for other computation/control tasks or save overall system power consumption.

The main architecture of the MCU is a multi-layer AHB-Lite bus structure with round-robin arbitration scheme. DMA and CPU core can access different slaves in parallel or same slaves sequentially.

DMA controller has 5 logic channels. Each logic channel is to serve memory access requests from single or multiple peripherals. Internal arbiter controls the priority of different DMA channels.

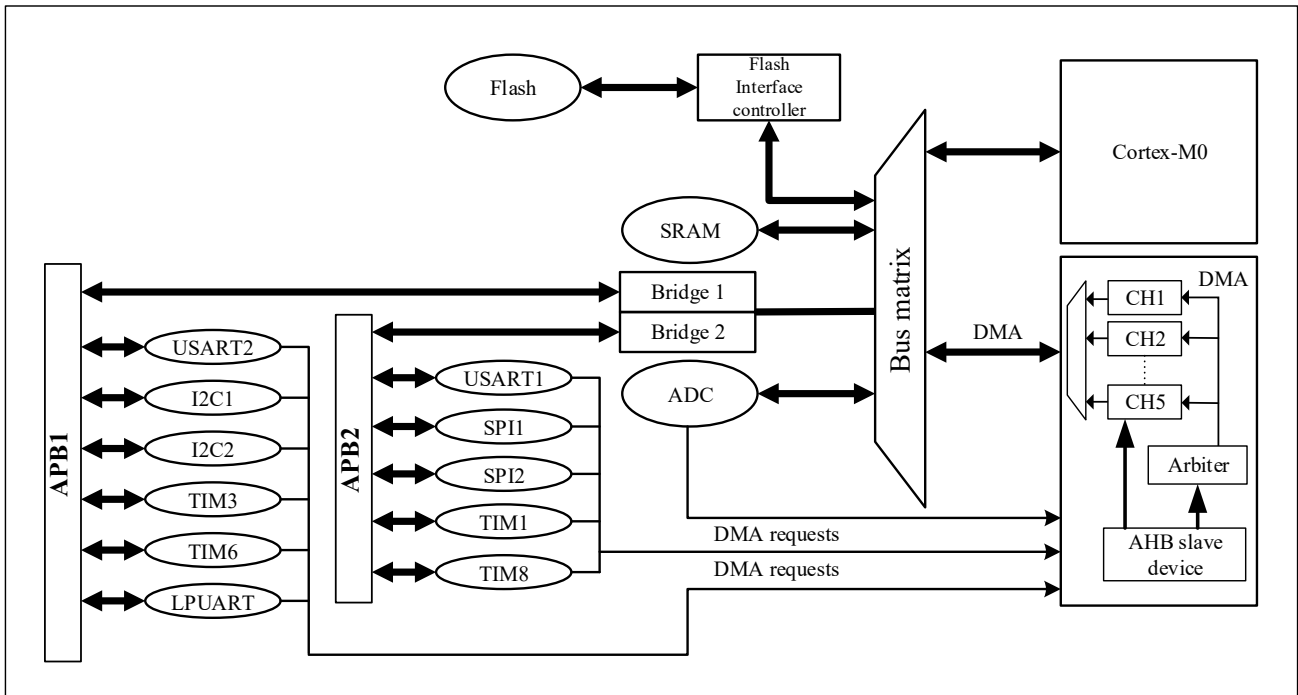
### 7.2 Main Features

DMA main features:

- 5 DMA channels which can be configured independently.
- Each DMA channel supports hardware requests and software triggers to initiate transfer, and is configured by software.
- Each DMA channel has dedicated software priority level (DMA\_CHCFGx.PRIOLVL [1:0] bits, corresponding to 4 levels of priority) which can be configured individually. Channels with the same software priority level will further compare hardware index (channel number) to decide final priority (lower index number channel will has higher priority).
- Configurable source and destination size. Address setting should correspond to data size.
- Configurable circular transfer mode for each channel.
- Each channel has 3 independent event flags and interrupts (Transfer complete, Half transfer, Transfer error), and 1 global interrupt flag (set by logical or of 3 events).
- Supports three transfer types which are Memory-to-Memory, Memory-to-Peripheral and Peripheral-to-Memory.
- Access totally 5 AHB slaves: Flash, SRAM, ADC, APB1 and APB2.
- Configurable data transmit number (0~65535).

### 7.3 Block Diagram

Figure 7-1 DMA Block Diagram



### 7.4 Function Description

DMA controller and Cortex<sup>®</sup>-M0 core share the same system data bus. When CPU and DMA access the same destination (RAM or peripheral) at the same time, DMA request will suspend CPU from accessing the system bus for several cycles, and the bus arbiter will perform round-robin scheduling. This allows the CPU to get at least half of the system bus (memory or peripheral) bandwidth.

#### 7.4.1 DMA Operation

A DMA request can be triggered by hardware peripherals or software, and the DMA controller processes the request according to the priority level of the channel. The data is read from the source address according to the configured transfer address and bit width, and then the read data is stored in the destination address space. After one operation, the controller calculates the number of remaining transfers and updates the source address and the destination address of the next transfer.

Each DMA data transfer consists of three operations:

- Data access: determine the source address (DMA\_PADDRx or DMA\_MADDRx) according to the transfer direction and read data from the source address.
- Data memory: determine the destination address (DMA\_PADDRx or DMA\_MADDRx) according to the transfer direction and store the read data into the destination address space.
- Calculate the number of outstanding operations, perform a decrement operation of the DMA\_TXNUMx register, and update the source and destination addresses of the next operation.

### 7.4.2 Channel Priority and Arbitration

The DMA uses an arbitration strategy to handle multiple requests from different channels. The priority of each channel is programmable in the channel control register (DMA\_CHCFGx).

4 levels of priority:

- Very high priority
- High priority
- Medium priority
- Low priority

By default, channel with lower index has higher priority if the programmed priority is the same.

For memory to memory transfer, re-arbitration is carried on after 4 transfer operations.

For transfer related to peripheral, re-arbitration is carried on after each transfer operation.

### 7.4.3 DMA Channels and Number Of Transfers

Each channel can perform DMA transfer between the peripheral register at the specified address and the memory address. The number of data transferred by DMA is programmable, and the maximum supported value is 65535. The DMA\_TXNUM register is decremented after each transfer.

### 7.4.4 Programmable Data Bit Width, Alignment and Endians

Peripheral and memory transfer data bit width supports byte, half-word and word, which can be programmed through DMA\_CHCFGx.PSIZE and DMA\_CHCFGx.MSIZE.

When DMA\_CHCFGx.PSIZE and DMA\_CHCFGx.MSIZE are different, the DMA module aligns the data according to the below.

**Table 7-1 Programmable Data Width and Endian Operation (When PINC = MINC = 1)**

| Source Width (bit) | Destination Width (bit) | Number Of Transfer (bit) | Source: Address / Data                       | Transfer Operations (R: Read, W: Write)  | Destination: Address / Data                          |
|--------------------|-------------------------|--------------------------|--|--|--|
| 8                  | 8                       | 4                        | 0x0 / B0<br>0x1 / B1<br>0x2 / B2<br>0x3 / B3 | 1: R B0 [7:0] @0x0, W B0 [7:0] @0x0<br>2: R B1 [7:0] @0x1, W B1 [7:0] @0x1<br>3: R B2 [7:0] @0x2, W B2 [7:0] @0x2<br>4: R B3 [7:0] @0x3, W B3 [7:0] @0x3             | 0x0 / B0<br>0x1 / B1<br>0x2 / B2<br>0x3 / B3         |
| 8                  | 16                      | 4                        | 0x0 / B0<br>0x1 / B1<br>0x2 / B2<br>0x3 / B3 | 1: R B0 [7:0] @0x0, W 00B0 [15:0] @0x0<br>2: R B1 [7:0] @0x1, W 00B1 [15:0] @0x2<br>3: R B2 [7:0] @0x2, W 00B2 [15:0] @0x4<br>4: R B3 [7:0] @0x3, W 00B3 [15:0] @0x6 | 0x0 / 00B0<br>0x2 / 00B1<br>0x4 / 00B2<br>0x6 / 00B3 |

| Source Width (bit) | Destination Width (bit) | Number Of Transfer (bit) | Source: Address / Data   | Transfer Operations (R: Read, W: Write)  | Destination: Address / Data  |
|--------------------|-------------------------|--------------------------|--|--|--|
| 8                  | 32                      | 4                        | 0x0 / B0<br>0x1 / B1<br>0x2 / B2<br>0x3 / B3                         | 1: R B0 [7:0] @0x0, W 000000B0 [31:0] @0x0<br>2: R B1 [7:0] @0x1, W 000000B1 [31:0] @0x4<br>3: R B2 [7:0] @0x2, W 000000B2 [31:0] @0x8<br>4: R B3 [7:0] @0x3, W 000000B3 [31:0] @0xC                             | 0x0 / 000000B0<br>0x4 / 000000B1<br>0x8 / 000000B2<br>0xC / 000000B3 |
| 16                 | 8                       | 4                        | 0x0 / B1B0<br>0x2 / B3B2<br>0x4 / B5B4<br>0x6 / B7B6                 | 1: R B1B0 [15:0] @0x0, W B0 [7:0] @0x0<br>2: R B3B2 [15:0] @0x2, W B2 [7:0] @0x1<br>3: R B5B4 [15:0] @0x4, W B4 [7:0] @0x2<br>4: R B7B6 [15:0] @0x6, W B6 [7:0] @0x3   | 0x0 / B0<br>0x1 / B2<br>0x2 / B4<br>0x3 / B6                         |
| 16                 | 16                      | 4                        | 0x0 / B1B0<br>0x2 / B3B2<br>0x4 / B5B4<br>0x6 / B7B6                 | 1: R B1B0 [15:0] @0x0, W B1B0 [15:0] @0x0<br>2: R B3B2 [15:0] @0x2, W B3B2 [15:0] @0x2<br>3: R B5B4 [15:0] @0x4, W B5B4 [15:0] @0x4<br>4: R B7B6 [15:0] @0x6, W B7B6 [15:0] @0x6                                 | 0x0 / B1B0<br>0x2 / B3B2<br>0x4 / B5B4<br>0x6 / B7B6                 |
| 16                 | 32                      | 4                        | 0x0 / B1B0<br>0x2 / B3B2<br>0x4 / B5B4<br>0x6 / B7B6                 | 1: R B1B0 [15:0] @0x0, W 0000B1B0 [31:0] @0x0<br>2: R B3B2 [15:0] @0x2, W 0000B3B2 [31:0] @0x4<br>3: R B5B4 [15:0] @0x4, W 0000B5B4 [31:0] @0x8<br>4: R B7B6 [15:0] @0x6, W 0000B7B6 [31:0] @0xC                 | 0x0 / 0000B1B0<br>0x4 / 0000B3B2<br>0x8 / 0000B5B4<br>0xC / 0000B7B6 |
| 32                 | 8                       | 4                        | 0x0 / B3B2B1B0<br>0x4 / B7B6B5B4<br>0x8 / BBBAB9B8<br>0xC / BFBEBDBC | 1: R B3B2B1B0 [31:0] @0x0, W B0 [7:0] @0x0<br>2: R B7B6B5B4 [31:0] @0x4, W B4 [7:0] @0x1<br>3: R BBBAB9B8 [31:0] @0x8, W B8 [7:0] @0x2<br>4: R BFBEBDBC [31:0] @0xC, W BC [7:0] @0x3                             | 0x0 / B0<br>0x1 / B4<br>0x2 / B8<br>0x3 / BC                         |
| 32                 | 16                      | 4                        | 0x0 / B3B2B1B0<br>0x4 / B7B6B5B4<br>0x8 / BBBAB9B8<br>0xC / BFBEBDBC | 1: R B3B2B1B0 [31:0] @0x0, W B1B0 [15:0] @0x0<br>2: R B7B6B5B4 [31:0] @0x4, W B5B4 [15:0] @0x2<br>3: R BBBAB9B8 [31:0] @0x8, W B9B8 [15:0] @0x4<br>4: R BFBEBDBC [31:0] @0xC, W BDBC [15:0] @0x6                 | 0x0 / B1B0<br>0x2 / B5B4<br>0x4 / B9B8<br>0x6 / BDBC                 |
| 32                 | 32                      | 4                        | 0x0 / B3B2B1B0<br>0x4 / B7B6B5B4<br>0x8 / BBBAB9B8<br>0xC / BFBEBDBC | 1: R B3B2B1B0 [31:0] @0x0, W B3B2B1B0 [31:0] @0x0<br>2: R B7B6B5B4 [31:0] @0x4, W B7B6B5B4 [31:0] @0x4<br>3: R BBBAB9B8 [31:0] @0x8, W BBBAB9B8 [31:0] @0x8<br>4: R BFBEBDBC [31:0] @0xC, W BFBEBDBC [31:0] @0xC | 0x0 / B3B2B1B0<br>0x4 / B7B6B5B4<br>0x8 / BBBAB9B8<br>0xC / BFBEBDBC |

*Notice:*

DMA always provide full 32-bits data to HWDATA[31:0] no matter what destination size it is (HSIZE still follows destination size setting for device supports byte/half-word operation). The HWDATA[31:0] follows the following rules:

- When source size is smaller than destination size, DMA pads the MSB with 0 until their sizes match and duplicates it to be 32 bits. E.g., source is 8 bits data 0x55 and destination size is 16 bits. DMA fills the source data with 0 to make it 16 bits and become 0x0055, then duplicate it to 32-bit data 0x0055\_0055 and provide to HWDATA[31:0]; (if destination size is 32-bit then DMA will only pad source data with 0).

- When source size is larger or equal to destination size and smaller than 32 bits, DMA duplicates source data to 32 bits data. E.g., source data is 8 bits data 0x1F, HWDATA[31:0] = 0x1F1F\_1F1F. if source data is 16 bits data 0x2345, then HWDATA[31:0] = 0x2345\_2345.

This ensures peripherals that only support word operation won't generate bus error and the desired data can still move to the place we want with extra bits i.e. 0 padding. If user wants to configure an 8-bit register but is aligned to a 32-bit address boundary, the source size should be set to 8 bits and destination to 32 bits so extra bits will be padded with 0.

#### 7.4.5 Peripheral/Memory Address Incrementation

DMA\_CHCFGx.PINC and DMA\_CHCFGx.MINC respectively control whether the peripheral address and memory address are enabled in auto-increment mode. The software cannot write (can read) the address register during transfer.

- In auto-increment mode, the next address to be transferred is automatically increased according to the data bit width (1, 2 or 4) after each transfer. The address of the first transfer is stored in DMA\_PADDRx or DMA\_MADDRx register.
- In fixed mode, the address is always fixed to the initial address.

At the end of transfer (i.e. the transfer count changes to 0), different processes will be carried out according to whether the current operate is under circular mode or not.

- In non-circular mode, DMA stops after the transfer is completed. To start a new DMA transfer, need to rewrite the transfer number in the DMA\_TXNUMx register with the DMA channel disabled.
- In circular mode, at the end of a transfer, the content of the DMA\_TXNUMx register will be automatically reloaded to its initial value, and the current internal peripheral or memory address register will also be reloaded to the initial base address set by the DMA\_PADDRx or DMA\_MADDRx register.

#### 7.4.6 Channel Configuration Process

The detail configuration process is as below:

1. Configure interrupt mask bits, 1: enable interrupts, 0 disable interrupts.
2. Configure channel peripheral address and memory address and transfer direction.
3. Configure channel priority, 0: lowest, 3: highest.
4. Configure peripheral and memory address increment.
5. Configure channel transfer block size.
6. If necessary, configure circular mode.
7. If it is memory to memory, configure MEM2MEM mode (*Note: to configure DMA to operate in M2M mode, user needs to set corresponding channel select value to reserved value, e.g., 47*).
8. Repeat step 1~8 on channel 1~8 and finally.
9. Enable corresponding channel.

If software is used to serve interrupt, software must enquire interrupt status register to check which interrupt occurred (software needs to write 1 to interrupt flag clear bit to clear the corresponding interrupt). Before enable channel, all



interrupts corresponding to the channel should be cleared.

If the interrupt is transfer complete interrupt, software can configure the next transfer, or report to user this channel transformation is done.

*Note: DMA user privilege management only supports that the user of the DMA configuration register is the same user as the DMA-enabled user, otherwise it will cause DMA transfer errors to occur.*

### 7.4.7 Flow Control

Three major flow controls are supported:

- Memory to memory
- Memory to peripheral
- Peripheral to memory

Flow control is controlled by two register bits in each DMA channel configuration register. Flow control is used to control source/destination and direction of DMA channel.

**Table 7-2 Flow Control Table**

| DMA_CHCFGx.MEM2MEM | DMA_CHCFGx.DIR | Source         | Destination    | Transfer   |
|--------------------|----------------|----------------|----------------|--|
| 1                  | x              | Memory         | Memory         | AHB read to AHB write, can do back2back transfer |
| 0                  | 1              | Memory         | AHB Peripheral | AHB read to AHB write, single transfer           |
|                    |                |                | APB Peripheral | AHB read to APB write, single transfer           |
| 0                  | 0              | AHB Peripheral | Memory         | AHB read to AHB write, single transfer           |
|                    |                | APB Peripheral |                | APB read to AHB write, single transfer           |

### 7.4.8 Circular Mode

The circular mode is used to process circular buffers and continuous data transmission (such as ADC scan mode). The DMA\_CHCFGx.CIRC is used to enable this function. When the circular mode is activated, if the number of data to be transferred becomes 0, it will automatically be restored to the initial value when configuring the channel, and the DMA operation will continue.

If the user wants to turn off the circular mode, the user needs to write 0 to DMA\_CHCFGx.CHEN to disable the DMA channel, and then write 0 to DMA\_CHCFGx.CIRC (when DMA\_CHCFGx.CHEN is 1, other bits in the DMA\_CHCFGx register cannot be rewritten).

### 7.4.9 Error Management

DMA access to a reserved address space will cause DMA transmission errors. When an error occurs, the transfer error flag is set, and the hardware automatically clears the current DMA channel enable bit (DMA\_CHCFGx.CHEN), and the channel operation is stopped. If the transfer error interrupt enable bit is set in the DMA\_CHCFGx register, an interrupt will be generated.

#### 7.4.10 Interrupt

- Transfer complete interrupt:

An interrupt is generated when channel data transfer is complete. Interrupt is a level signal. Each channel has its dedicated interrupt, interrupt mask control and interrupt status bit. Interrupt status bit is cleared when interrupt flag clear bit is set.

- Half transfer interrupt:

An interrupt is generated when half of the channel data is transferred. Interrupt is a level signal. Each channel has its dedicated interrupt, interrupt mask control and interrupt status bit. Interrupt status bit is cleared when interrupt flag clear bit is set.

- Transfer error interrupt:

An interrupt is generated when bus returned error. Interrupt is a level signal. Each channel has its dedicated interrupt, interrupt mask control and interrupt status bit. Interrupt status bit is cleared when interrupt flag clear bit is set.

**Table 7-3 DMA Interrupt Request**

| Interrupt Event   | Event Flag Bit | Enable Control Bit |
|-------------------|----------------|--------------------|
| Half transfer     | HTXF           | HTXIE              |
| Transfer complete | TXCF           | TXCIE              |
| Transfer error    | ERRF           | ERRIE              |

#### 7.4.11 DMA Request Mapping

Totally there are 35 DMA requests from all the peripherals. To have better support with full flexibility, register bits can be used to select which DMA request is mapped to which DMA channel. The table below shows the mapping scheme of peripherals' DMA request to DMA controller's DMA channels.

Table 7-4 DMA Request Mapping

| DMA Channel Select | Peripheral DMA Request | DMA Channel Select | Peripheral DMA Request |
|--------------------|------------------------|--------------------|------------------------|
| sel = 0            | adc_dma                | sel = 24           | Tim1_ch2               |
| sel = 1            | Usart1_tx              | sel = 25           | Tim1_ch3               |
| sel = 2            | Usart1_rx              | sel = 26           | Tim1_ch4               |
| sel = 3            | Usart2_tx              | sel = 27           | Tim1_com               |
| sel = 4            | Usart2_rx              | sel = 28           | Tim1_up                |
| sel = 5            | Lpuart_tx              | sel = 29           | Tim1_trig              |
| sel = 6            | Lpuart_rx              | sel = 30           | Tim8_ch1               |
| sel = 7            | Reserved               | sel = 31           | Tim8_ch2               |
| sel = 8            | Reserved               | sel = 32           | Tim8_ch3               |
| sel = 9            | Reserved               | sel = 33           | Tim8_ch4               |
| sel = 10           | Reserved               | sel = 34           | Tim8_com               |
| sel = 11           | Reserved               | sel = 35           | Tim8_up                |
| sel = 12           | Reserved               | sel = 36           | Tim8_trig              |
| sel = 13           | Spi1_tx                | sel = 37           | Tim3_ch1               |
| sel = 14           | Spi1_rx                | sel = 38           | Tim3_ch3               |
| sel = 15           | Spi2_tx                | sel = 39           | Tim3_ch4               |
| sel = 16           | Spi2_rx                | sel = 40           | Tim3_up                |
| sel = 17           | Reserved               | sel = 41           | Tim3_trig              |
| sel = 18           | Reserved               | sel = 42           | Reserved               |
| sel = 19           | I <sup>2</sup> c1_tx   | sel = 43           | Reserved               |
| sel = 20           | I <sup>2</sup> c1_rx   | sel = 44           | Reserved               |
| sel = 21           | I <sup>2</sup> c2_tx   | sel = 45           | Reserved               |
| sel = 22           | I <sup>2</sup> c2_rx   | sel = 46           | TIM6                   |
| sel = 23           | Tim1_ch1               |                    |                        |

## 7.5 DMA Registers

### 7.5.1 DMA Register Overview

Table 7-5 DMA Register Overview

| Offset | Register    | 31         | 30 | 29 | 28 | 27 | 26 | 25 | 24 | 23 | 22 | 21 | 20 | 19 | 18         | 17     | 16            | 15     | 14         | 13     | 12         | 11     | 10     | 9      | 8      | 7      | 6      | 5      | 4      | 3      | 2      | 1      | 0      |        |   |   |   |   |   |   |   |
|--------|-------------|------------|----|----|----|----|----|----|----|----|----|----|----|----|------------|--------|---------------|--------|------------|--------|------------|--------|--------|--------|--------|--------|--------|--------|--------|--------|--------|--------|--------|--------|---|---|---|---|---|---|---|
| 000h   | DMA_INTSTS  | Reserved   |    |    |    |    |    |    |    |    |    |    |    |    | ERRF5      | HTXF5  | TXCF5         | GLBF5  | ERRF4      | HTXF4  | TXCF4      | GLBF4  | ERRF3  | HTXF3  | TXCF3  | GLBF3  | ERRF2  | HTXF2  | TXCF2  | GLBF2  | ERRF1  | HTXF1  | TXCF1  | GLBF1  |   |   |   |   |   |   |   |
|        | Reset Value | 0          |    |    |    |    |    |    |    |    |    |    |    |    | 0          | 0      | 0             | 0      | 0          | 0      | 0          | 0      | 0      | 0      | 0      | 0      | 0      | 0      | 0      | 0      | 0      | 0      | 0      | 0      | 0 | 0 | 0 | 0 | 0 | 0 | 0 |
| 004h   | DMA_INTCLR  | Reserved   |    |    |    |    |    |    |    |    |    |    |    |    | CERRF5     | CHTXF5 | CTXCF5        | CGLBF5 | CERRF4     | CHTXF4 | CTXCF4     | CGLBF4 | CERRF3 | CHTXF3 | CTXCF3 | CGLBF3 | CERRF2 | CHTXF2 | CTXCF2 | CGLBF2 | CERRF1 | CHTXF1 | CTXCF1 | CGLBF1 |   |   |   |   |   |   |   |
|        | Reset Value | 0          |    |    |    |    |    |    |    |    |    |    |    |    | 0          | 0      | 0             | 0      | 0          | 0      | 0          | 0      | 0      | 0      | 0      | 0      | 0      | 0      | 0      | 0      | 0      | 0      | 0      | 0      | 0 | 0 | 0 | 0 | 0 | 0 | 0 |
| 008h   | DMA_CHCFG1  | Reserved   |    |    |    |    |    |    |    |    |    |    |    |    | MEM2MEM    |        | PRIORITY[1:0] |        | MSIZE[1:0] |        | PSIZE[1:0] |        | MINC   | PINC   | CIRC   | DIR    | ERRIE  | HTXIE  | TXCIE  | CHEN   |        |        |        |        |   |   |   |   |   |   |   |
|        | Reset Value | 0          |    |    |    |    |    |    |    |    |    |    |    |    | 0          | 0      | 0             | 0      | 0          | 0      | 0          | 0      | 0      | 0      | 0      | 0      | 0      | 0      | 0      | 0      | 0      | 0      | 0      | 0      | 0 | 0 | 0 | 0 | 0 | 0 | 0 |
| 00Ch   | DMA_TXNUM1  | Reserved   |    |    |    |    |    |    |    |    |    |    |    |    | NDTX[15:0] |        |               |        |            |        |            |        |        |        |        |        |        |        |        |        |        |        |        |        |   |   |   |   |   |   |   |
|        | Reset Value | 0          |    |    |    |    |    |    |    |    |    |    |    |    | 0          | 0      | 0             | 0      | 0          | 0      | 0          | 0      | 0      | 0      | 0      | 0      | 0      | 0      | 0      | 0      | 0      | 0      | 0      | 0      | 0 | 0 | 0 | 0 | 0 | 0 | 0 |
| 010h   | DMA_PADDR1  | ADDR[31:0] |    |    |    |    |    |    |    |    |    |    |    |    |            |        |               |        |            |        |            |        |        |        |        |        |        |        |        |        |        |        |        |        |   |   |   |   |   |   |   |

| Offset | Register    | 31         | 30 | 29 | 28 | 27 | 26 | 25 | 24 | 23 | 22 | 21 | 20 | 19 | 18 | 17 | 16         | 15 | 14 | 13      | 12           | 11         | 10         | 9    | 8    | 7    | 6   | 5           | 4     | 3     | 2    | 1 | 0 |   |   |   |   |   |   |   |   |   |   |   |   |   |   |
|--------|-------------|------------|----|----|----|----|----|----|----|----|----|----|----|----|----|----|------------|----|----|---------|--------------|------------|------------|------|------|------|-----|-------------|-------|-------|------|---|---|---|---|---|---|---|---|---|---|---|---|---|---|---|---|
|        | Reset Value | 0          | 0  | 0  | 0  | 0  | 0  | 0  | 0  | 0  | 0  | 0  | 0  | 0  | 0  | 0  | 0          | 0  | 0  | 0       | 0            | 0          | 0          | 0    | 0    | 0    | 0   | 0           | 0     | 0     | 0    | 0 | 0 | 0 |   |   |   |   |   |   |   |   |   |   |   |   |   |
| 014h   | DMA_MADDR1  | ADDR[31:0] |    |    |    |    |    |    |    |    |    |    |    |    |    |    |            |    |    |         |              |            |            |      |      |      |     |             |       |       |      |   |   |   |   |   |   |   |   |   |   |   |   |   |   |   |   |
|        | Reset Value | 0          | 0  | 0  | 0  | 0  | 0  | 0  | 0  | 0  | 0  | 0  | 0  | 0  | 0  | 0  | 0          | 0  | 0  | 0       | 0            | 0          | 0          | 0    | 0    | 0    | 0   | 0           | 0     | 0     | 0    | 0 | 0 | 0 |   |   |   |   |   |   |   |   |   |   |   |   |   |
| 018h   | DMA_CHSEL1  | Reserved   |    |    |    |    |    |    |    |    |    |    |    |    |    |    |            |    |    |         |              |            |            |      |      |      |     | CH_SEL[5:0] |       |       |      |   |   |   |   |   |   |   |   |   |   |   |   |   |   |   |   |
|        | Reset Value |            |    |    |    |    |    |    |    |    |    |    |    |    |    |    |            |    |    |         |              |            |            |      |      |      |     | 0           | 0     | 0     | 0    | 0 | 0 |   |   |   |   |   |   |   |   |   |   |   |   |   |   |
| 01Ch   | DMA_CHCFG2  | Reserved   |    |    |    |    |    |    |    |    |    |    |    |    |    |    |            |    |    | MEM2MEM | PRIOLVL[1:0] | MSIZE[1:0] | PSIZE[1:0] | MINC | PINC | CIRC | DIR | ERRIE       | HTXIE | TXCIE | CHEN |   |   |   |   |   |   |   |   |   |   |   |   |   |   |   |   |
|        | Reset Value |            |    |    |    |    |    |    |    |    |    |    |    |    |    |    |            |    |    | 0       | 0            | 0          | 0          | 0    | 0    | 0    | 0   | 0           | 0     | 0     | 0    | 0 | 0 | 0 | 0 | 0 |   |   |   |   |   |   |   |   |   |   |   |
| 020h   | DMA_TXNUM2  | Reserved   |    |    |    |    |    |    |    |    |    |    |    |    |    |    | NDTX[15:0] |    |    |         |              |            |            |      |      |      |     |             |       |       |      |   |   |   |   |   |   |   |   |   |   |   |   |   |   |   |   |
|        | Reset Value |            |    |    |    |    |    |    |    |    |    |    |    |    |    |    | 0          | 0  | 0  | 0       | 0            | 0          | 0          | 0    | 0    | 0    | 0   | 0           | 0     | 0     | 0    | 0 | 0 | 0 | 0 | 0 | 0 | 0 | 0 | 0 | 0 | 0 | 0 | 0 | 0 | 0 |   |
| 024h   | DMA_PADDR2  | ADDR[31:0] |    |    |    |    |    |    |    |    |    |    |    |    |    |    |            |    |    |         |              |            |            |      |      |      |     |             |       |       |      |   |   |   |   |   |   |   |   |   |   |   |   |   |   |   |   |
|        | Reset Value | 0          | 0  | 0  | 0  | 0  | 0  | 0  | 0  | 0  | 0  | 0  | 0  | 0  | 0  | 0  | 0          | 0  | 0  | 0       | 0            | 0          | 0          | 0    | 0    | 0    | 0   | 0           | 0     | 0     | 0    | 0 | 0 | 0 |   |   |   |   |   |   |   |   |   |   |   |   |   |
| 028h   | DMA_MADDR2  | ADDR[31:0] |    |    |    |    |    |    |    |    |    |    |    |    |    |    |            |    |    |         |              |            |            |      |      |      |     |             |       |       |      |   |   |   |   |   |   |   |   |   |   |   |   |   |   |   |   |
|        | Reset Value | 0          | 0  | 0  | 0  | 0  | 0  | 0  | 0  | 0  | 0  | 0  | 0  | 0  | 0  | 0  | 0          | 0  | 0  | 0       | 0            | 0          | 0          | 0    | 0    | 0    | 0   | 0           | 0     | 0     | 0    | 0 | 0 | 0 |   |   |   |   |   |   |   |   |   |   |   |   |   |
| 02Ch   | DMA_CHSEL2  | Reserved   |    |    |    |    |    |    |    |    |    |    |    |    |    |    |            |    |    |         |              |            |            |      |      |      |     | CH_SEL[5:0] |       |       |      |   |   |   |   |   |   |   |   |   |   |   |   |   |   |   |   |
|        | Reset Value |            |    |    |    |    |    |    |    |    |    |    |    |    |    |    |            |    |    |         |              |            |            |      |      |      |     | 0           | 0     | 0     | 0    | 0 | 0 |   |   |   |   |   |   |   |   |   |   |   |   |   |   |
| 030h   | DMA_CHCFG3  | Reserved   |    |    |    |    |    |    |    |    |    |    |    |    |    |    |            |    |    | MEM2MEM | PRIOLVL[1:0] | MSIZE[1:0] | PSIZE[1:0] | MINC | PINC | CIRC | DIR | ERRIE       | HTXIE | TXCIE | CHEN |   |   |   |   |   |   |   |   |   |   |   |   |   |   |   |   |
|        | Reset Value |            |    |    |    |    |    |    |    |    |    |    |    |    |    |    |            |    |    | 0       | 0            | 0          | 0          | 0    | 0    | 0    | 0   | 0           | 0     | 0     | 0    | 0 | 0 | 0 | 0 | 0 |   |   |   |   |   |   |   |   |   |   |   |
| 034h   | DMA_TXNUM3  | Reserved   |    |    |    |    |    |    |    |    |    |    |    |    |    |    | NDTX[15:0] |    |    |         |              |            |            |      |      |      |     |             |       |       |      |   |   |   |   |   |   |   |   |   |   |   |   |   |   |   |   |
|        | Reset Value |            |    |    |    |    |    |    |    |    |    |    |    |    |    |    | 0          | 0  | 0  | 0       | 0            | 0          | 0          | 0    | 0    | 0    | 0   | 0           | 0     | 0     | 0    | 0 | 0 | 0 | 0 | 0 | 0 | 0 | 0 | 0 | 0 | 0 | 0 | 0 | 0 | 0 |   |
| 038h   | DMA_PADDR3  | ADDR[31:0] |    |    |    |    |    |    |    |    |    |    |    |    |    |    |            |    |    |         |              |            |            |      |      |      |     |             |       |       |      |   |   |   |   |   |   |   |   |   |   |   |   |   |   |   |   |
|        | Reset Value | 0          | 0  | 0  | 0  | 0  | 0  | 0  | 0  | 0  | 0  | 0  | 0  | 0  | 0  | 0  | 0          | 0  | 0  | 0       | 0            | 0          | 0          | 0    | 0    | 0    | 0   | 0           | 0     | 0     | 0    | 0 | 0 | 0 |   |   |   |   |   |   |   |   |   |   |   |   |   |
| 03Ch   | DMA_MADDR3  | ADDR[31:0] |    |    |    |    |    |    |    |    |    |    |    |    |    |    |            |    |    |         |              |            |            |      |      |      |     |             |       |       |      |   |   |   |   |   |   |   |   |   |   |   |   |   |   |   |   |
|        | Reset Value | 0          | 0  | 0  | 0  | 0  | 0  | 0  | 0  | 0  | 0  | 0  | 0  | 0  | 0  | 0  | 0          | 0  | 0  | 0       | 0            | 0          | 0          | 0    | 0    | 0    | 0   | 0           | 0     | 0     | 0    | 0 | 0 | 0 |   |   |   |   |   |   |   |   |   |   |   |   |   |
| 040h   | DMA_CHSEL3  | Reserved   |    |    |    |    |    |    |    |    |    |    |    |    |    |    |            |    |    |         |              |            |            |      |      |      |     | CH_SEL[5:0] |       |       |      |   |   |   |   |   |   |   |   |   |   |   |   |   |   |   |   |
|        | Reset Value |            |    |    |    |    |    |    |    |    |    |    |    |    |    |    |            |    |    |         |              |            |            |      |      |      |     | 0           | 0     | 0     | 0    | 0 | 0 |   |   |   |   |   |   |   |   |   |   |   |   |   |   |
| 044h   | DMA_CHCFG4  | Reserved   |    |    |    |    |    |    |    |    |    |    |    |    |    |    |            |    |    | MEM2MEM | PRIOLVL[1:0] | MSIZE[1:0] | PSIZE[1:0] | MINC | PINC | CIRC | DIR | ERRIE       | HTXIE | TXCIE | CHEN |   |   |   |   |   |   |   |   |   |   |   |   |   |   |   |   |
|        | Reset Value |            |    |    |    |    |    |    |    |    |    |    |    |    |    |    |            |    |    | 0       | 0            | 0          | 0          | 0    | 0    | 0    | 0   | 0           | 0     | 0     | 0    | 0 | 0 | 0 | 0 | 0 |   |   |   |   |   |   |   |   |   |   |   |
| 048h   | DMA_TXNUM4  | Reserved   |    |    |    |    |    |    |    |    |    |    |    |    |    |    | NDTX[15:0] |    |    |         |              |            |            |      |      |      |     |             |       |       |      |   |   |   |   |   |   |   |   |   |   |   |   |   |   |   |   |
|        | Reset Value |            |    |    |    |    |    |    |    |    |    |    |    |    |    |    | 0          | 0  | 0  | 0       | 0            | 0          | 0          | 0    | 0    | 0    | 0   | 0           | 0     | 0     | 0    | 0 | 0 | 0 | 0 | 0 | 0 | 0 | 0 | 0 | 0 | 0 | 0 | 0 | 0 | 0 | 0 |
| 04Ch   | DMA_PADDR4  | ADDR[31:0] |    |    |    |    |    |    |    |    |    |    |    |    |    |    |            |    |    |         |              |            |            |      |      |      |     |             |       |       |      |   |   |   |   |   |   |   |   |   |   |   |   |   |   |   |   |
|        | Reset Value | 0          | 0  | 0  | 0  | 0  | 0  | 0  | 0  | 0  | 0  | 0  | 0  | 0  | 0  | 0  | 0          | 0  | 0  | 0       | 0            | 0          | 0          | 0    | 0    | 0    | 0   | 0           | 0     | 0     | 0    | 0 | 0 | 0 |   |   |   |   |   |   |   |   |   |   |   |   |   |
| 050h   | DMA_MADDR4  | ADDR[31:0] |    |    |    |    |    |    |    |    |    |    |    |    |    |    |            |    |    |         |              |            |            |      |      |      |     |             |       |       |      |   |   |   |   |   |   |   |   |   |   |   |   |   |   |   |   |
|        | Reset Value | 0          | 0  | 0  | 0  | 0  | 0  | 0  | 0  | 0  | 0  | 0  | 0  | 0  | 0  | 0  | 0          | 0  | 0  | 0       | 0            | 0          | 0          | 0    | 0    | 0    | 0   | 0           | 0     | 0     | 0    | 0 | 0 | 0 |   |   |   |   |   |   |   |   |   |   |   |   |   |
| 054h   | DMA_CHSEL4  | Reserved   |    |    |    |    |    |    |    |    |    |    |    |    |    |    |            |    |    |         |              |            |            |      |      |      |     | CH_SEL[5:0] |       |       |      |   |   |   |   |   |   |   |   |   |   |   |   |   |   |   |   |
|        | Reset Value |            |    |    |    |    |    |    |    |    |    |    |    |    |    |    |            |    |    |         |              |            |            |      |      |      |     | 0           | 0     | 0     | 0    | 0 | 0 |   |   |   |   |   |   |   |   |   |   |   |   |   |   |
| 058h   | DMA_CHCFG5  | Reserved   |    |    |    |    |    |    |    |    |    |    |    |    |    |    |            |    |    | MEM2MEM | PRIOLVL[1:0] | MSIZE[1:0] | PSIZE[1:0] | MINC | PINC | CIRC | DIR | ERRIE       | HTXIE | TXCIE | CHEN |   |   |   |   |   |   |   |   |   |   |   |   |   |   |   |   |
|        | Reset Value |            |    |    |    |    |    |    |    |    |    |    |    |    |    |    |            |    |    | 0       | 0            | 0          | 0          | 0    | 0    | 0    | 0   | 0           | 0     | 0     | 0    | 0 | 0 | 0 | 0 | 0 |   |   |   |   |   |   |   |   |   |   |   |
| 05Ch   | DMA_TXNUM5  | Reserved   |    |    |    |    |    |    |    |    |    |    |    |    |    |    | NDTX[15:0] |    |    |         |              |            |            |      |      |      |     |             |       |       |      |   |   |   |   |   |   |   |   |   |   |   |   |   |   |   |   |
|        | Reset Value |            |    |    |    |    |    |    |    |    |    |    |    |    |    |    | 0          | 0  | 0  | 0       | 0            | 0          | 0          | 0    | 0    | 0    | 0   | 0           | 0     | 0     | 0    | 0 | 0 | 0 | 0 | 0 | 0 | 0 | 0 | 0 | 0 | 0 | 0 | 0 | 0 | 0 | 0 |
| 060h   | DMA_PADDR5  | ADDR[31:0] |    |    |    |    |    |    |    |    |    |    |    |    |    |    |            |    |    |         |              |            |            |      |      |      |     |             |       |       |      |   |   |   |   |   |   |   |   |   |   |   |   |   |   |   |   |
|        | Reset Value | 0          | 0  | 0  | 0  | 0  | 0  | 0  | 0  | 0  | 0  | 0  | 0  | 0  | 0  | 0  | 0          | 0  | 0  | 0       | 0            | 0          | 0          | 0    | 0    | 0    | 0   | 0           | 0     | 0     | 0    | 0 | 0 | 0 |   |   |   |   |   |   |   |   |   |   |   |   |   |
| 064h   | DMA_MADDR5  | ADDR[31:0] |    |    |    |    |    |    |    |    |    |    |    |    |    |    |            |    |    |         |              |            |            |      |      |      |     |             |       |       |      |   |   |   |   |   |   |   |   |   |   |   |   |   |   |   |   |
|        | Reset Value | 0          | 0  | 0  | 0  | 0  | 0  | 0  | 0  | 0  | 0  | 0  | 0  | 0  | 0  | 0  | 0          | 0  | 0  | 0       | 0            | 0          | 0          | 0    | 0    | 0    | 0   | 0           | 0     | 0     | 0    | 0 | 0 | 0 |   |   |   |   |   |   |   |   |   |   |   |   |   |
| 068h   | DMA_CHSEL5  | Reserved   |    |    |    |    |    |    |    |    |    |    |    |    |    |    |            |    |    |         |              |            |            |      |      |      |     | CH_SEL[5:0] |       |       |      |   |   |   |   |   |   |   |   |   |   |   |   |   |   |   |   |
|        | Reset Value |            |    |    |    |    |    |    |    |    |    |    |    |    |    |    |            |    |    |         |              |            |            |      |      |      |     | 0           | 0     | 0     | 0    | 0 | 0 |   |   |   |   |   |   |   |   |   |   |   |   |   |   |

**7.5.2 DMA Interrupt Status Register (DMA\_INTSTS)**

Address offset: 0x00

Reset value: 0x0000 0000

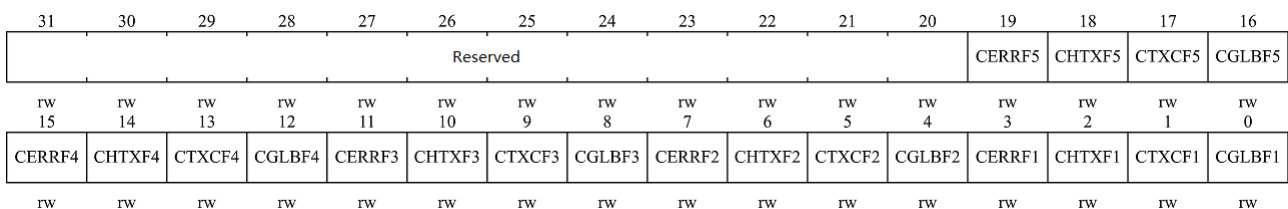
|          |       |       |       |       |       |       |       |       |       |       |       |       |       |       |       |
|----------|-------|-------|-------|-------|-------|-------|-------|-------|-------|-------|-------|-------|-------|-------|-------|
| 31       | 30    | 29    | 28    | 27    | 26    | 25    | 24    | 23    | 22    | 21    | 20    | 19    | 18    | 17    | 16    |
| Reserved |       |       |       |       |       |       |       |       |       |       |       | ERRF5 | HTXF5 | TXCF5 | GLBF5 |
| r        | r     | r     | r     | r     | r     | r     | r     | r     | r     | r     | r     | r     | r     | r     | r     |
| 15       | 14    | 13    | 12    | 11    | 10    | 9     | 8     | 7     | 6     | 5     | 4     | 3     | 2     | 1     | 0     |
| ERRF4    | HTXF4 | TXCF4 | GLBF4 | ERRF3 | HTXF3 | TXCF3 | GLBF3 | ERRF2 | HTXF2 | TXCF2 | GLBF2 | ERRF1 | HTXF1 | TXCF1 | GLBF1 |
| r        | r     | r     | r     | r     | r     | r     | r     | r     | r     | r     | r     | r     | r     | r     | r     |

| Bit Field    | Name              | Description   |
|--------------|-------------------|---|
| 19/15/11/7/3 | ERRF <sub>x</sub> | Transfer error flag for channel x (x=1...5).<br>Hardware sets this bit when transfer error happen. This bit is cleared by software by writing '1' to DMA_INTCLR.CERRF <sub>x</sub> bit.<br>0: Transfer error no happened on channel x.<br>1: Transfer error happened on channel x.  |
| 18/14/10/6/2 | HTXF <sub>x</sub> | Half transfer flag for channel x (x=1...5).<br>Hardware sets this bit when half transfer is done. This bit is cleared by software by writing '1' to DMA_INTCLR.CHTXF <sub>x</sub> bit.<br>0: Half transfer not yet done on channel x.<br>1: Half transfer was done on channel x.  |
| 17/13/9/5/1  | TXCF <sub>x</sub> | Transfer complete flag for channel x (x=1...5).<br>Hardware sets this bit when transfer is done. This bit is cleared by software by writing '1' to DMA_INTCLR.CTXCF <sub>x</sub> bit.<br>0: Transfer not yet done on channel x.<br>1: Transfer was done on channel x.   |
| 16/12/8/4/0  | GLBF <sub>x</sub> | Global flag for channel x (x=1...5).<br>Hardware sets this bit when any interrupt events happen in this channel. This bit is cleared by software by writing '1' to DMA_INTCLR.CGLBF <sub>x</sub> bit.<br>0: No transfer error, half transfer or transfer done event happen on channel x.<br>1: One of transfer error, half transfer or transfer done event happen on channel x. |

### 7.5.3 DMA Interrupt Flag Clear Register (DMA\_INTCLR)

Address offset: 0x04

Reset value: 0x0000 0000



| Bit Field    | Name               | Description  |
|--------------|--------------------|--|
| 19/15/11/7/3 | CERRF <sub>x</sub> | Clear transfer error flag for channel x (x=1...5).<br>Software can set this bit to clear ERRF of corresponding channel.<br>0: No action.<br>1: Reset DMA_INTSTS.ERRF bit of corresponding channel. |
| 18/14/10/6/2 | CHTXF <sub>x</sub> | Clear half transfer flag for channel x (x=1...5).<br>Software can set this bit to clear HTXF of corresponding channel.<br>0: No action.<br>1: Reset DMA_INTSTS.HTXF bit of corresponding channel.  |
| 17/13/9/5/1  | CTXCF <sub>x</sub> | Clear transfer complete flag for channel x (x=1...5).  |

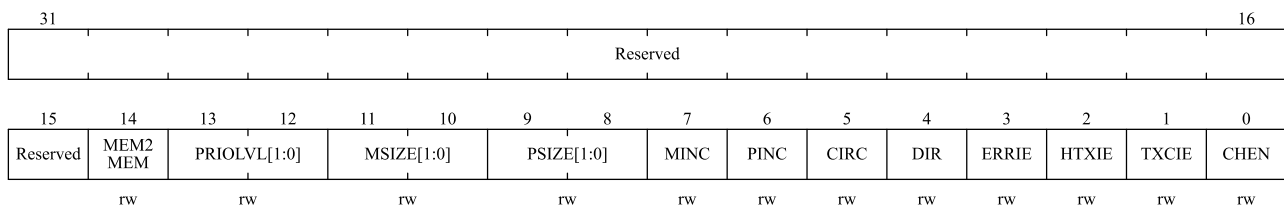
| Bit Field   | Name   | Description  |
|-------------|--------|--|
|             |        | Software can set this bit to clear TXCF of corresponding channel.<br>0: No action.<br>1: Reset DMA_INTSTS.TXCF bit of corresponding channel.   |
| 16/12/8/4/0 | CGLBFx | Clear global event flag for channel x (x=1...5).<br>Software can set this bit to clear GLBF of corresponding channel.<br>0: No action.<br>1: Reset DMA_INTSTS.GLBF bit of corresponding channel. |

### 7.5.4 DMA Channel x Configuration Register (DMA\_CHCFGx)

Note: The x is channel number, x = 1...5

Address offset: 0x08+20 \* (x-1)

Reset value: 0x0000 0000



| Bit Field | Name         | Description  |
|-----------|--------------|--|
| 31:15     | Reserved     | Reserved, the reset value must be maintained.  |
| 14        | MEM2MEM      | Memory to memory mode.<br>Software can configure this channel to memory to memory transfer when it is not yet enabled.<br>0: Channel transfer between memory and peripheral.<br>1: Channel set to memory to memory transfer. |
| 13:12     | PRIOLVL[1:0] | Channel priority.<br>Software can program channel priority when channel is not enable.<br>00: Low<br>01: Medium<br>10: High<br>11: Very high   |
| 11:10     | MSIZE[1:0]   | Memory data size.<br>Software can configure data size read/write from/to memory address.<br>00: 8-bits<br>01: 16-bits<br>10: 32-bits<br>11: Reserved   |
| 9:8       | PSIZE[1:0]   | Peripheral data size.<br>Software can configure data size read/write from/to peripheral address.<br>00: 8-bits   |

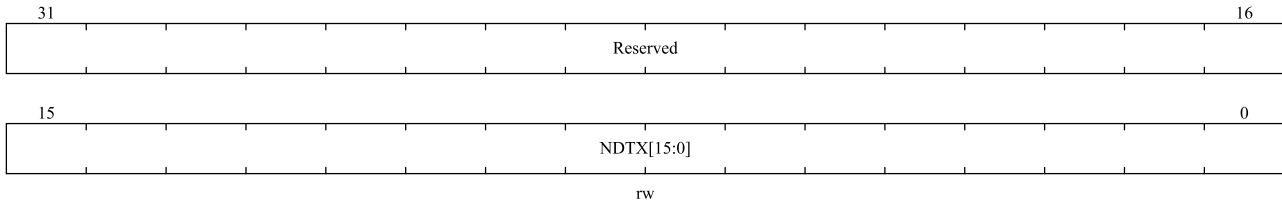
| Bit Field | Name  | Description  |
|-----------|-------|--|
|           |       | 01: 16-bits<br>10: 32-bits<br>11: Reserved   |
| 7         | MINC  | Memory increment mode.<br>Software can enable/disable memory address increment mode.<br>0: Memory address won't increase with each transfer.<br>1: Memory address increase with each transfer.                 |
| 6         | PINC  | Peripheral increment mode.<br>Software can enable/disable peripheral address increment mode.<br>0: Peripheral address won't increase with each transfer.<br>1: Peripheral address increase with each transfer. |
| 5         | CIRC  | Circular mode.<br>Software can set/clear this bit.<br>0: Channel will stop after one round of transfer.<br>1: Channel configure as circular mode.  |
| 4         | DIR   | Data transfer direction<br>Software can set/clear this bit.<br>0: Data transfer from Peripheral to Memory<br>1: Data transfer from Memory to Peripheral.   |
| 3         | ERRIE | Transfer error interrupt enable.<br>Software can enable/disable transfer error interrupt.<br>0: Disable transfer error interrupt of channel x.<br>1: Enable transfer error interrupt of channel x.             |
| 2         | HTXIE | Half transfer interrupt enable.<br>Software can enable/disable half transfer interrupt.<br>0: Disable half transfer interrupt of channel x.<br>1: Enable half transfer interrupt of channel x.                 |
| 1         | TXCIE | Transfer complete interrupt enable.<br>Software can enable/disable transfer complete interrupt.<br>0: Disable transfer complete interrupt of channel x.<br>1: Enable transfer complete interrupt of channel x. |
| 0         | CHEN  | Channel enable.<br>Software can set/reset this bit.<br>0: Disable channel.<br>1: Enable channel.   |

### 7.5.5 DMA Channel x Transfer Number Register (DMA\_TXNUMx)

*Note: The x is channel number, x = 1...5*

Address offset: 0x0C+20 \* (x-1)

Reset value: 0x0000 0000



| Bit Field | Name     | Description  |
|-----------|----------|--|
| 31:16     | Reserved | Reserved, the reset value must be maintained.  |
| 15:0      | NDTX     | Number of data to transfer.<br>Number of data to be transferred (0~65535). Software can read/write the number of transfers when channel is disable and it will be read only after channel enable. Every successful transfer of corresponding DMA channel will decrease this register by 1. If circular mode is enable, it will automatically reload pre-set value when it reach zero. Otherwise it will keep at zero and reset channel enable. |

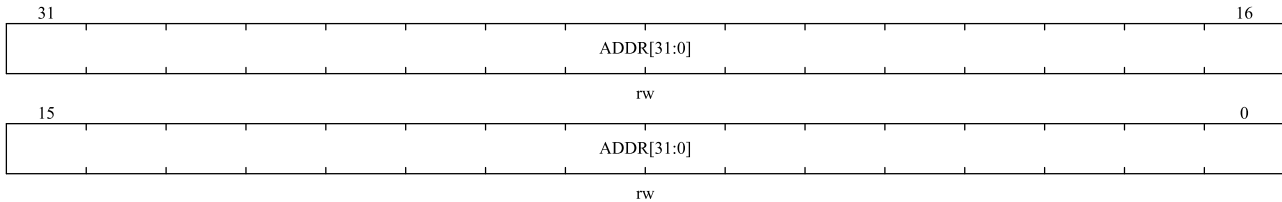
**7.5.6 DMA Channel x Peripheral Address Register (DMA\_PADDRx)**

Note: The x is channel number, x = 1...5

Address offset: 0x10+20 \* (x-1)

Reset value: 0x0000 0000

This register can only be written if the channel is disabled (DMA\_CHCFGx.CHEN = 0).



| Bit Field | Name | Description  |
|-----------|------|--|
| 31:0      | ADDR | Peripheral address.<br>Peripheral starting address for DMA to read/write from/to.<br>Increment of address will be decided by DMA_CHCFGx.PSIZE. With DMA_CHCFGx.PSIZE equal to 01, DMA ignores bit 0 of PADDR and if DMA_CHCFGx.PSIZE equal to 10 DMA will ignore bit [1:0] of PADDR. |

**7.5.7 DMA Channel x Memory Address Register (DMA\_MADDRx)**

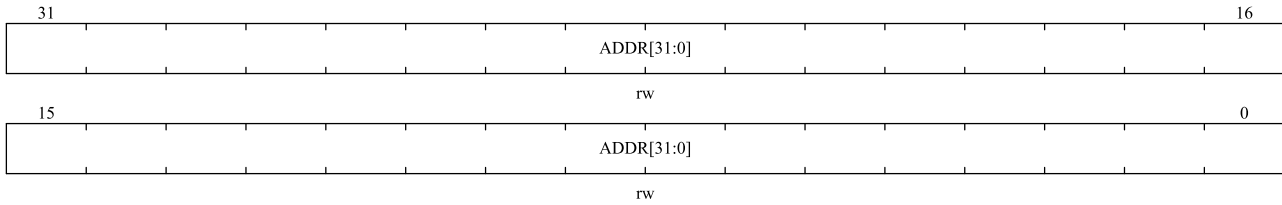
Note: The x is channel number, x = 1...5

Address offset: 0x14+20 \* (x-1)

Reset value: 0x0000 0000

This register can only be written if the channel is disabled (DMA\_CHCFGx.CHEN = 0).





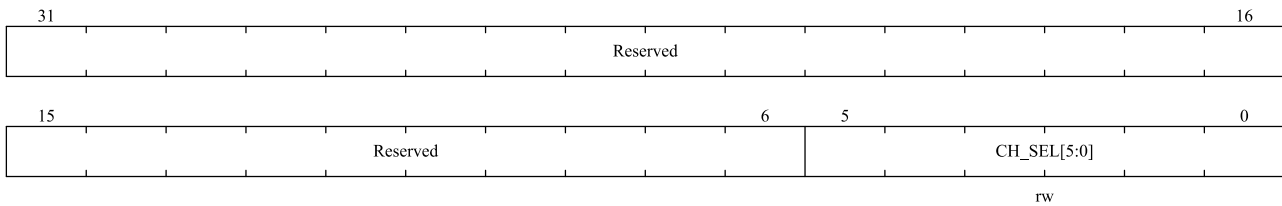
| Bit Field | Name | Description   |
|-----------|------|---|
| 31:0      | ADDR | ADDR Memory address.<br>Memory starting address for DMA to read/write from/to.<br>Increment of address will be decided by DMA_CHCFGx.MSIZE. With DMA_CHCFGx.MSIZE equal to 01, DMA ignores bit 0 of MADDR and if DMA_CHCFGx.MSIZE equal to 10 DMA will ignore bit [1:0] of MADDR. |

### 7.5.8 DMA Channel x Channel Request Select Register (DMA\_CHSELx)

Note: The x is channel number, x = 1...5

Address offset: 0x18+20 \* (x-1)

Reset value: 0x0000 0000



| Bit Field | Name        | Description  |
|-----------|-------------|--|
| 31:6      | Reserved    | Reserved, the reset value must be maintained.  |
| 5:0       | CH_SEL[5:0] | DMA channel request selection<br>0x00: adc_dma<br>.....<br>0x2E: TIM6<br>For the mapping of peripheral DMA requests to DMA input request channel numbers, please refer to <b>Table 7-4</b> |

## 8 CRC Calculation Unit

### 8.1 CRC Introduction

This module integrates the functions of CRC32 and CRC16, and the cyclic redundancy check (CRC) calculation unit obtains any CRC calculation result according to a fixed generator polynomial. In other applications, CRC technology is mainly used to verify the correctness and integrity of data transmission or data memory. EN/IEC 60335-1 provides a method to verify the integrity of Flash memory. CRC calculation unit can calculate the signature of the software when the program is running, then compare it with the reference signature generated during connection, and then store it in the specified memory space.

### 8.2 CRC Main Features

#### 8.2.1 CRC32 Module

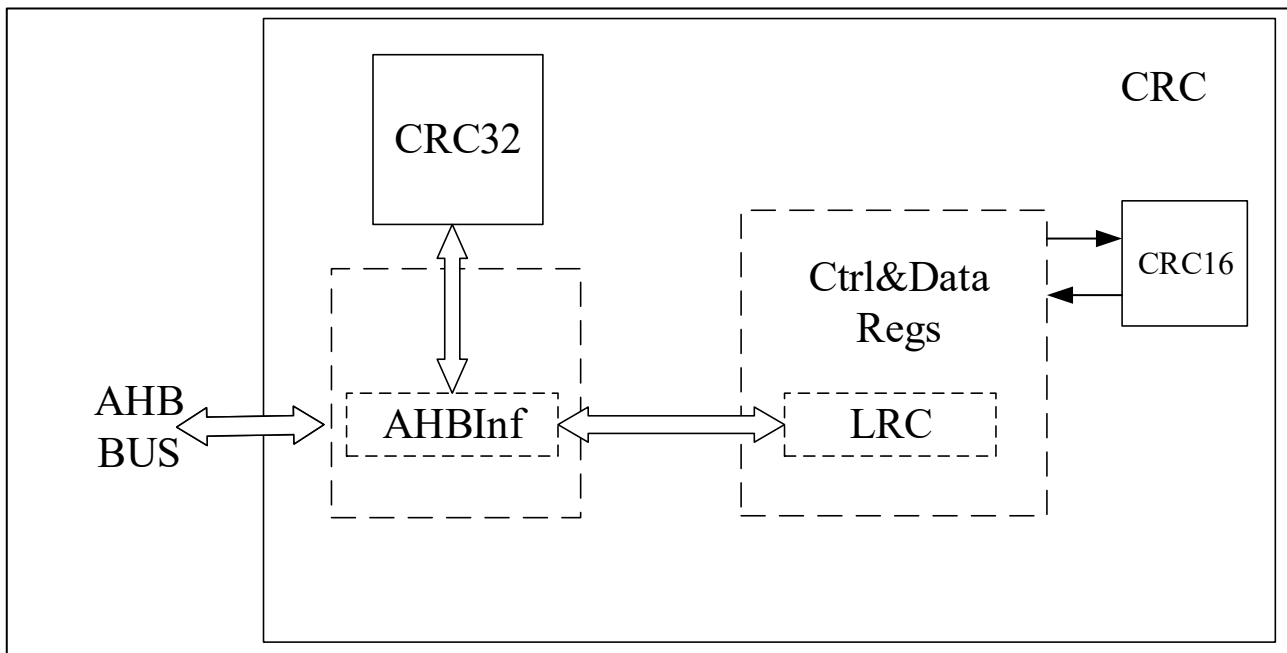
- $CRC32(X^{32}+X^{26}+X^{23}+X^{22}+X^{16}+X^{12}+X^{11}+X^{10}+X^8+X^7+X^5+X^4+X^2+X+1)$
- 32 bits of data to be checked and 32 bits of output check code.
- CRC calculation time: 1 AHB clock cycles (HCLK)
- General-purpose 8-bit register (can be used to store temporary data)

#### 8.2.2 CRC16 Module

- $CRC16(X^{16}+X^{15}+X^2+1)$
- There are 8 bits of data to be checked and 16 bits of output check code.
- CRC calculation time: 1 AHB clock cycle (HCLK)
- The verification initial value can be configured, and the size end of the data to be verified can be configured.
- Supports 8bit LRC check value generation

The following figure is the block diagram of CRC unit.

Figure 8-1 CRC Calculation Unit Block Diagram



## 8.3 CRC Function Description

### 8.3.1 CRC32

CRC calculation unit contains one 32-bit data register:

- Writing this register to input CRC data.
- Reading this register to get the calculated CRC result.

Every writing operation to this data register triggers the calculation of this new data with the previous calculation result (CRC calculation is performed on the whole 32-bit word rather than byte by byte).

Supports back-to-back writes or sequential write-read operations.

CRC\_CRC32DAT can be re-initialized to 0xFFFFFFFF by setting CRC\_CRC32CTRL.RESET. This operation does not affect the data in register CRC\_CRC32IDAT.

### 8.3.2 CRC16

CRC\_CRC16CTRL.ENDHL controls Little Endian format or Big Endian format.

To clear the result of the last CRC operation, set CRC\_CRC16CTRL.CLR to 1 or CRC\_CRC16D to 0.

The initial value of CRC calculation can be configured by writing the CRC\_CRC16D register. By default, the initial value is the result of the last calculation.

LRC calculation is the same as CRC calculation. Both are carried out at the same time. CRC or LRC can be read out depending on needs. If the initial value needs to be set, the LRC register should be configured first.

## 8.4 CRC Registers

### 8.4.1 CRC Register Overview

The following table lists the registers and reset values of CRC.

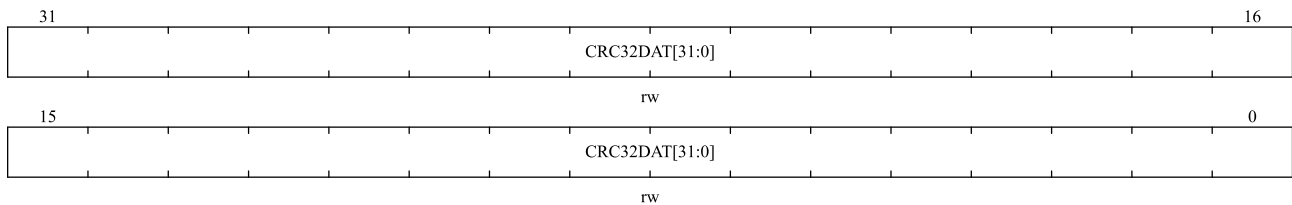
**Table 8-1 CRC Register Overview**

| Offset | Register    | 31             | 30 | 29 | 28 | 27 | 26 | 25 | 24 | 23 | 22 | 21 | 20 | 19           | 18 | 17 | 16 | 15 | 14 | 13 | 12 | 11 | 10 | 9 | 8 | 7              | 6 | 5 | 4 | 3   | 2     | 1        | 0 |   |
|--------|-------------|----------------|----|----|----|----|----|----|----|----|----|----|----|--------------|----|----|----|----|----|----|----|----|----|---|---|----------------|---|---|---|-----|-------|----------|---|---|
| 000h   | CRC32DAT    | CRC32DAT[31:0] |    |    |    |    |    |    |    |    |    |    |    |              |    |    |    |    |    |    |    |    |    |   |   |                |   |   |   |     |       |          |   |   |
|        | Reset Value | 1              | 1  | 1  | 1  | 1  | 1  | 1  | 1  | 1  | 1  | 1  | 1  | 1            | 1  | 1  | 1  | 1  | 1  | 1  | 1  | 1  | 1  | 1 | 1 | 1              | 1 | 1 | 1 | 1   | 1     | 1        | 1 |   |
| 004h   | CRC32IDAT   | Reserved       |    |    |    |    |    |    |    |    |    |    |    |              |    |    |    |    |    |    |    |    |    |   |   | CRC32IDAT[7:0] |   |   |   |     |       |          |   |   |
|        | Reset Value |                |    |    |    |    |    |    |    |    |    |    |    |              |    |    |    |    |    |    |    |    |    |   |   | 0              | 0 | 0 | 0 | 0   | 0     | 0        | 0 |   |
| 008h   | CRC32CTRL   | Reserved       |    |    |    |    |    |    |    |    |    |    |    |              |    |    |    |    |    |    |    |    |    |   |   |                |   |   |   |     |       |          |   |   |
|        | Reset Value |                |    |    |    |    |    |    |    |    |    |    |    |              |    |    |    |    |    |    |    |    |    |   |   |                |   |   |   |     |       |          |   |   |
| 00Ch   | CRC16CTRL   | Reserved       |    |    |    |    |    |    |    |    |    |    |    |              |    |    |    |    |    |    |    |    |    |   |   |                |   |   |   | CLR | ENDHL | Reserved |   |   |
|        | Reset Value |                |    |    |    |    |    |    |    |    |    |    |    |              |    |    |    |    |    |    |    |    |    |   |   |                |   |   |   | 0   | 0     |          |   |   |
| 010h   | CRC16DAT    | Reserved       |    |    |    |    |    |    |    |    |    |    |    |              |    |    |    |    |    |    |    |    |    |   |   | CRC16DAT[7:0]  |   |   |   |     |       |          |   |   |
|        | Reset Value |                |    |    |    |    |    |    |    |    |    |    |    |              |    |    |    |    |    |    |    |    |    |   |   | 0              | 0 | 0 | 0 | 0   | 0     | 0        | 0 | 0 |
| 014h   | CRC16D      | Reserved       |    |    |    |    |    |    |    |    |    |    |    | CRC16D[15:0] |    |    |    |    |    |    |    |    |    |   |   |                |   |   |   |     |       |          |   |   |
|        | Reset Value |                |    |    |    |    |    |    |    |    |    |    |    | 0            | 0  | 0  | 0  | 0  | 0  | 0  | 0  | 0  | 0  | 0 | 0 | 0              | 0 | 0 | 0 | 0   | 0     | 0        |   |   |
| 018h   | LRC         | Reserved       |    |    |    |    |    |    |    |    |    |    |    |              |    |    |    |    |    |    |    |    |    |   |   | LRCDAT[7:0]    |   |   |   |     |       |          |   |   |
|        | Reset Value |                |    |    |    |    |    |    |    |    |    |    |    |              |    |    |    |    |    |    |    |    |    |   |   | 0              | 0 | 0 | 0 | 0   | 0     | 0        | 0 | 0 |

### 8.4.2 CRC32 Data Register (CRC\_CRC32DAT)

Address offset: 0x00

Reset value: 0xFFFF FFFF

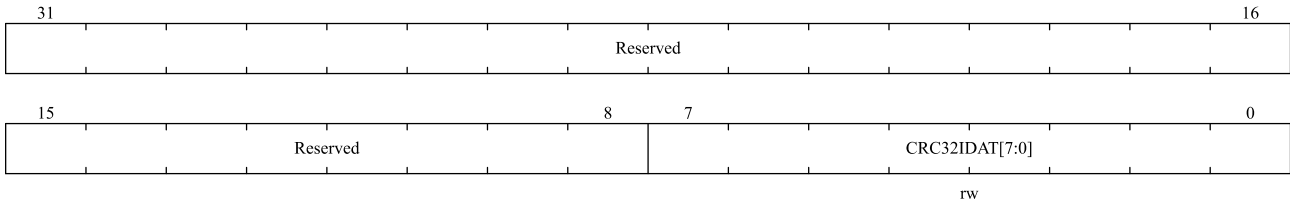


| Bit Field | Name           | Description   |
|-----------|----------------|---|
| 31:0      | CRC32DAT[31:0] | CRC32 Data register.<br>The written data is the CRC value to be checked. The read data is the CRC calculation result. Only 32-bit operations are supported. |

### 8.4.3 CRC32 Independent Data Register (CRC\_CRC32IDAT)

Address offset: 0x04

Reset value: 0x0000 0000



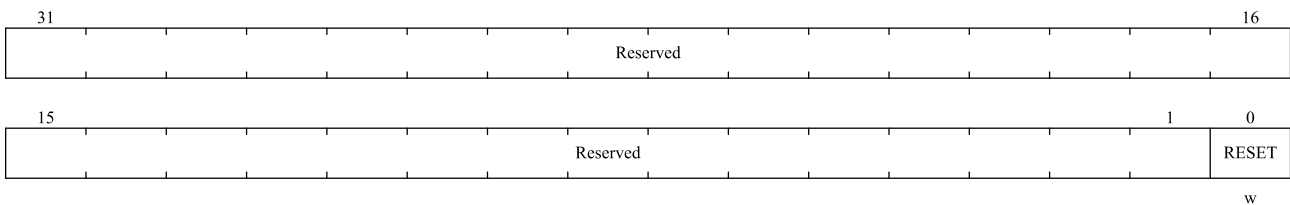
| Bit Field | Name           | Description  |
|-----------|----------------|--|
| 31:8      | Reserved       | Reserved, the reset value must be maintained   |
| 7:0       | CRC32IDAT[7:0] | Independent 8-bit data register.<br>General 8 bits data register. It is for temporary stored 1-byte data. CRC_ CRC32CTRL.RESET bit reset signal will not impact this register. |

Note: This register is not a part of CRC calculation and can be used to store any data.

### 8.4.4 CRC32 Control Register (CRC\_ CRC32CTRL)

Address offset: 0x08

Reset value: 0x0000 0000

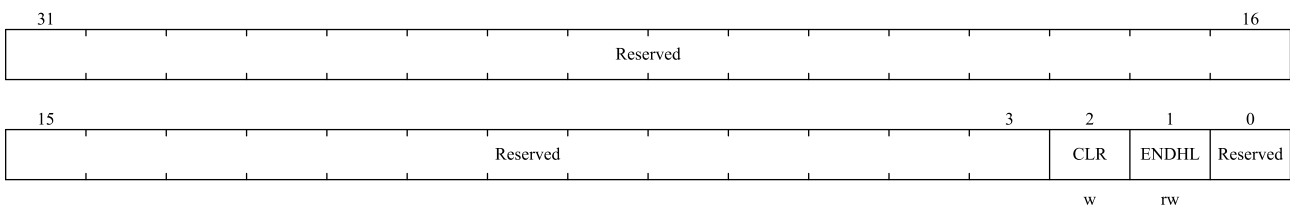


| Bit Field | Name     | Description  |
|-----------|----------|--|
| 31:1      | Reserved | Reserved, the reset value must be maintained   |
| 0         | RESET    | RESET signal.<br>It can reset CRC32 module and set data register to be 0xFFFF_FFFF. This reset can only write 1, and hardware will clear to 0 automatically. |

### 8.4.5 CRC16 Control Register (CRC\_ CRC16CTRL)

Address offset: 0x0C

Reset value: 0x0000 0000



| Bit Field | Name     | Description                                  |
|-----------|----------|--|
| 31:3      | Reserved | Reserved, the reset value must be maintained |

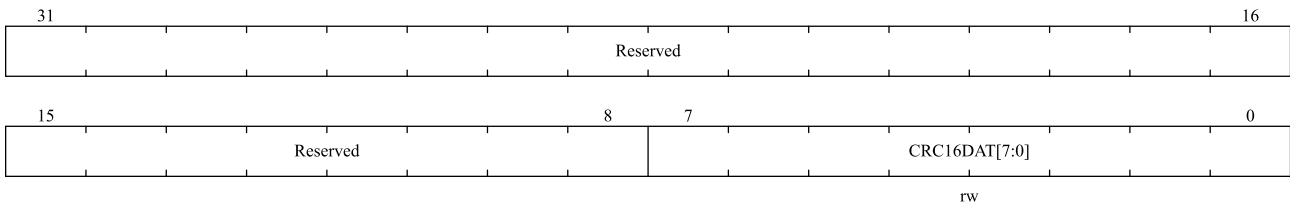
| Bit Field | Name     | Description   |
|-----------|----------|---|
| 2         | CLR      | Clear CRC16 results.<br>0: Not clear.<br>1: Clear to default value 0x0000. Set this bit to 1 will only maintain 1 clock cycle, hardware will clear automatically. (Software read always 0). |
| 1         | ENDHL    | Data to be verified start to calculate from MSB or LSB.<br>0: From MSB to LSB<br>1: From LSB to MSB<br>This bit is only for data to be verified.  |
| 0         | Reserved | Reserved,the reset value must be maintained   |

Note: 8-bits, 16-bits and 32-bits operations are supported.

### 8.4.6 CRC16 Input Data Register (CRC\_CRC16DAT)

Address offset: 0x10

Reset value: 0x0000 0000



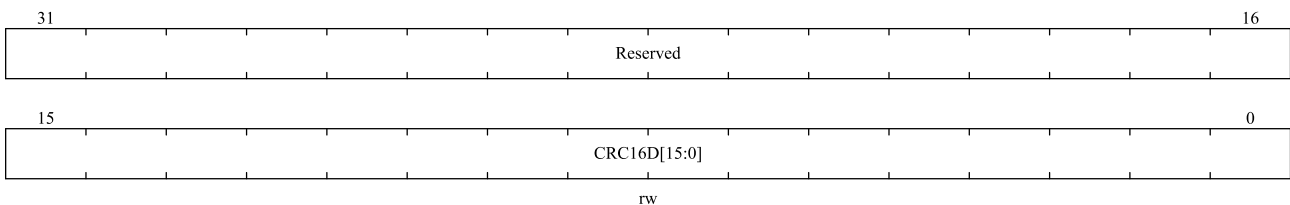
| Bit Field | Name          | Description                                 |
|-----------|---------------|---|
| 31:8      | Reserved      | Reserved,the reset value must be maintained |
| 7:0       | CRC16DAT[7:0] | Data to be verified.                        |

Note: 8-bits, 16-bits and 32-bits operations are supported.

### 8.4.7 CRC Cyclic Redundancy Check Code Register (CRC\_CRC16D)

Address offset: 0x14

Reset value: 0x0000 0000



| Bit Field | Name         | Description   |
|-----------|--------------|---|
| 31:16     | Reserved     | Reserved,the reset value must be maintained   |
| 15:0      | CRC16D[15:0] | 16-bit value of cyclic redundancy result data.<br>Every time the software writes the CRC16DAT register, the 16-bit calculated data from |

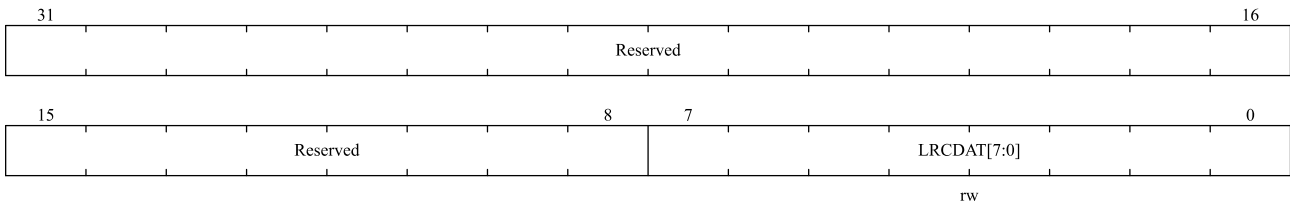
| Bit Field | Name | Description                        |
|-----------|------|------------------------------------|
|           |      | CRC16 is updated in this register. |

*Note: 8-bits, 16-bits and 32-bits operations are supported (8-bit operations must be performed twice in a row to ensure that 16-bit initial values are configured properly)*

### 8.4.8 LRC Result Register (CRC\_LRC)

Address offset: 0x18

Reset value: 0x0000 0000



| Bit Field | Name        | Description  |
|-----------|-------------|--|
| 31:8      | Reserved    | Reserved, the reset value must be maintained   |
| 7:0       | LRCDAT[7:0] | LRC check value register.<br>Software need to write initial value before use. And then each writing data to CRCDR will be XOR with LCR register value. The result will be stored in LRC. Software read the result. It should be cleared before next use. |

## 9 Advanced Control Timers (TIM1 and TIM8)

### 9.1 TIM1 and TIM8 Introduction

The advanced control timers (TIM1 and TIM8) are mainly used for counting the input signal, measuring the pulse width of the input signal and generating the output waveforms, etc.

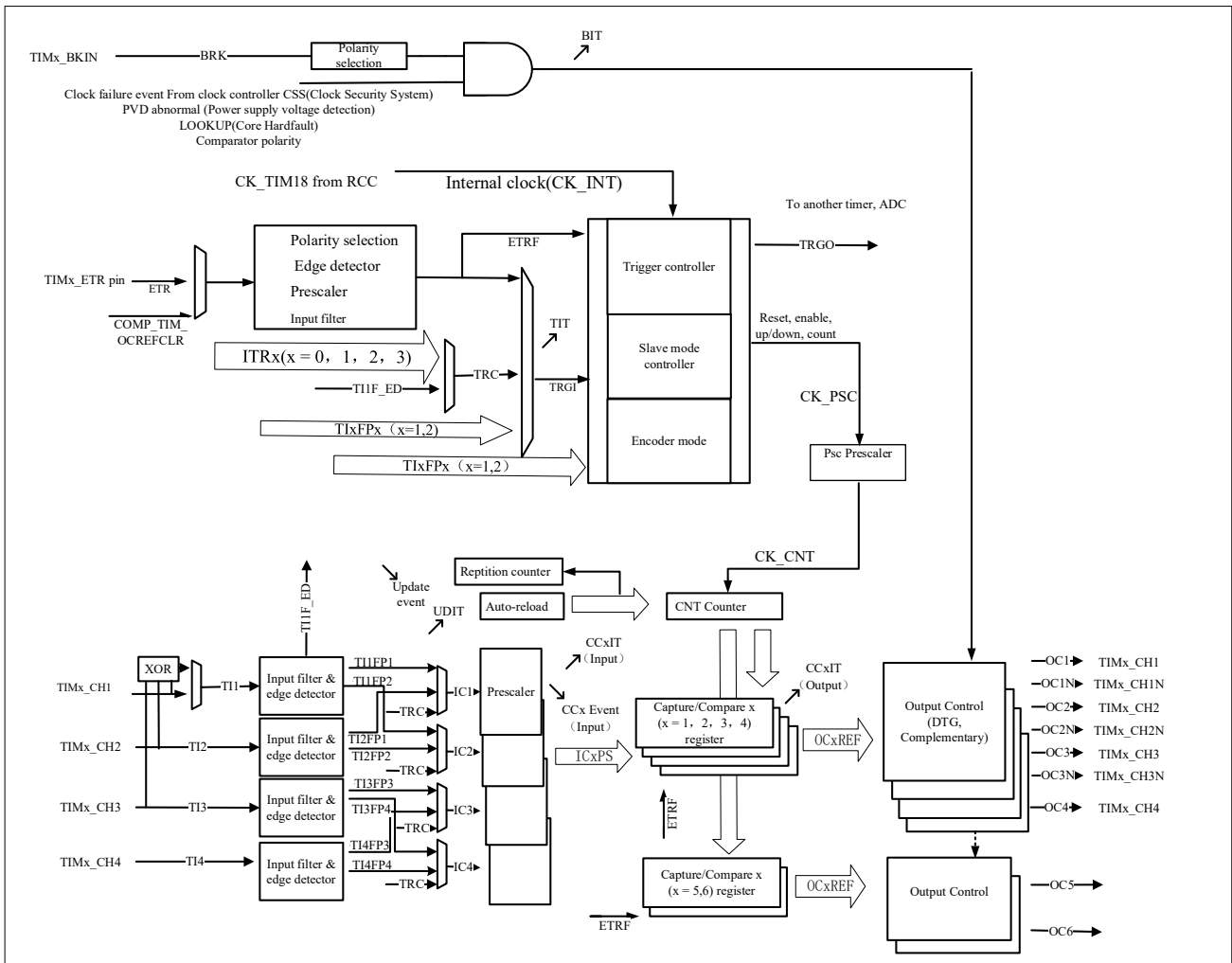
Advanced control timers have functions such as complementary output functions, dead-time insertion and break functions, which are suitable for motor control.

### 9.2 Main Features of TIM1 and TIM8

- 16-bit auto-reload counters. (It can realize up-counting, down-counting, up/down counting)
- 16-bit programmable prescaler. (The prescaler factor can be configured with any value between 1 and 65536)
- Programmable repetition counter
- TIM1 and TIM8 up to 6 channels
- 4 capture/compare channels, the operating modes are PWM output, output compare, one-pulse mode output, input capture
- Timer can be controlled by external signal
- Timers can be linked together internally for timer synchronization or chaining
- TIM1\_OC5 and TIM8\_OC5 for COMP blanking
- TIM1\_OC6 for switch the master and slave channels of OPAMP
- The events that generate the interrupt/DMA are as follows:
  - Update event
  - Trigger event
  - Input capture
  - Output compare
  - Break signal input
- Complementary outputs with programmable dead-time
  - For TIM1 and TIM8, channel 1,2,3 support this feature
- Incremental (quadrature) encoder interface: it is used for tracking motion and resolving rotation direction and position
- Hall sensor interface: it is used to do three-phase motor control



Figure 9-1 Block Diagram of TIM1 and TIM8



↙ The event                      ↗ Interrupt and DMA output

The capture channel 1 input can come from IOM or comparator output

### 9.3 TIM1 and TIM8 Function Description

#### 9.3.1 Time-base Unit

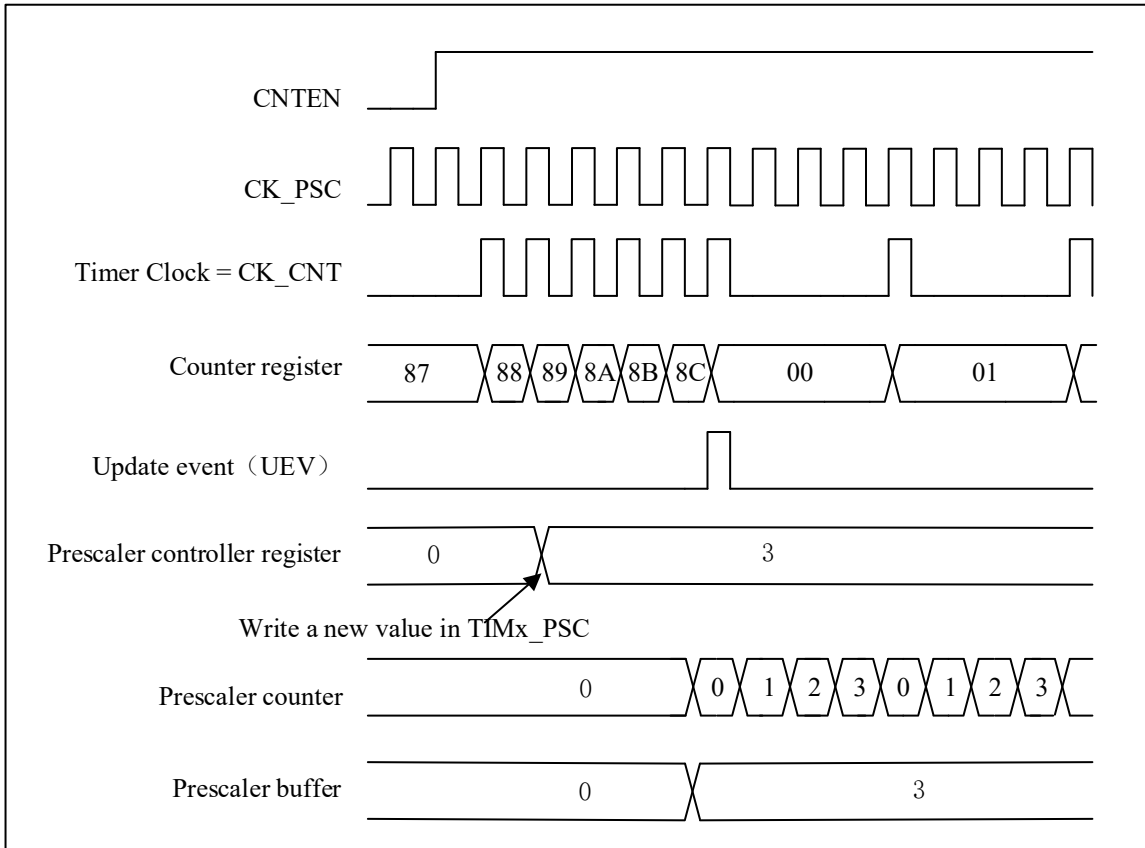
The advanced-control timer's time-base unit mainly includes: prescaler, counter, auto-reload and repetition counter. When the timebase unit is operating, user can read and write the corresponding registers (TIMx\_PSC, TIMx\_CNT, TIMx\_AR and TIMx\_REPCNT) at any time by the software.

Depending on the setting of the auto-reload preload enable bit (TIMx\_CTRL1.ARPEN), the value of the preload register is transferred to the shadow register immediately or at each update event UEV. When TIMx\_CTRL1.UPDIS=0, a counter overflow/underflow or software setting TIMx\_EVTGEN.UDGN will generate an update event. The counter CK\_CNT is valid only when the TIMx\_CTRL1.CNTEN bit is set. The counter starts counting one clock cycle after the TIMx\_CTRL1.CNTEN bit is set.

**9.3.1.1 Prescaler description**

The TIMx\_PSC register consists of a 16-bit counter that can be used to divide the counter clock frequency by any factor between 1 and 65536. Because this controller has a buffer, it can be dynamically changed at runtime. The new prescaler value will only be adopted during the next update event.

**Figure 9-2 Counter Timing Diagram with Prescaler Division Change from 1 to 4**



**9.3.2 Counter Mode**

**9.3.2.1 Up-counting mode**

In up-counting mode, the counter will count from 0 to the value of the register TIMx\_AR, then it resets to 0. And a counter overflow event is generated.

If the TIMx\_CTRL1.UPRS bit (selecting update request) and the TIMx\_EVTGEN.UDGN bit are set, an update event (UEV) will be generated. And TIMx\_STS.UDITF will not be set by hardware, therefore, no update interrupts or update DMA requests will be generated. This is to avoid generating an update interrupt when clearing the counter.

Depending on the configuration of TIMx\_CTRL1.UPRS, When an update event occurs, all registers are updated and the TIMx\_STS.UDITF is set:

- The repetition counter reloads the contents of the TIMx\_REPCNT
- Update auto-reload shadow registers with preload value(TIMx\_AR), when TIMx\_CTRL1.ARPEN = 1.
- The prescaler shadow register is reloaded with the preload value(TIMx\_PSC).

To avoid updating the shadow registers when new values are written to the preload registers, you can disable the update by setting `TIMx_CTRL1.UPDIS=1`.

When an update event is generated, the counter will still be cleared and the prescaler counter will also be set to 0 (but the prescaler value will remain unchanged).

The figures below show some examples of the counter behavior and the update flags for different prescaler factors in the up-counting mode.

**Figure 9-3 Timing Diagram of Up-counting. The Internal Clock Divider Factor = 2/N**

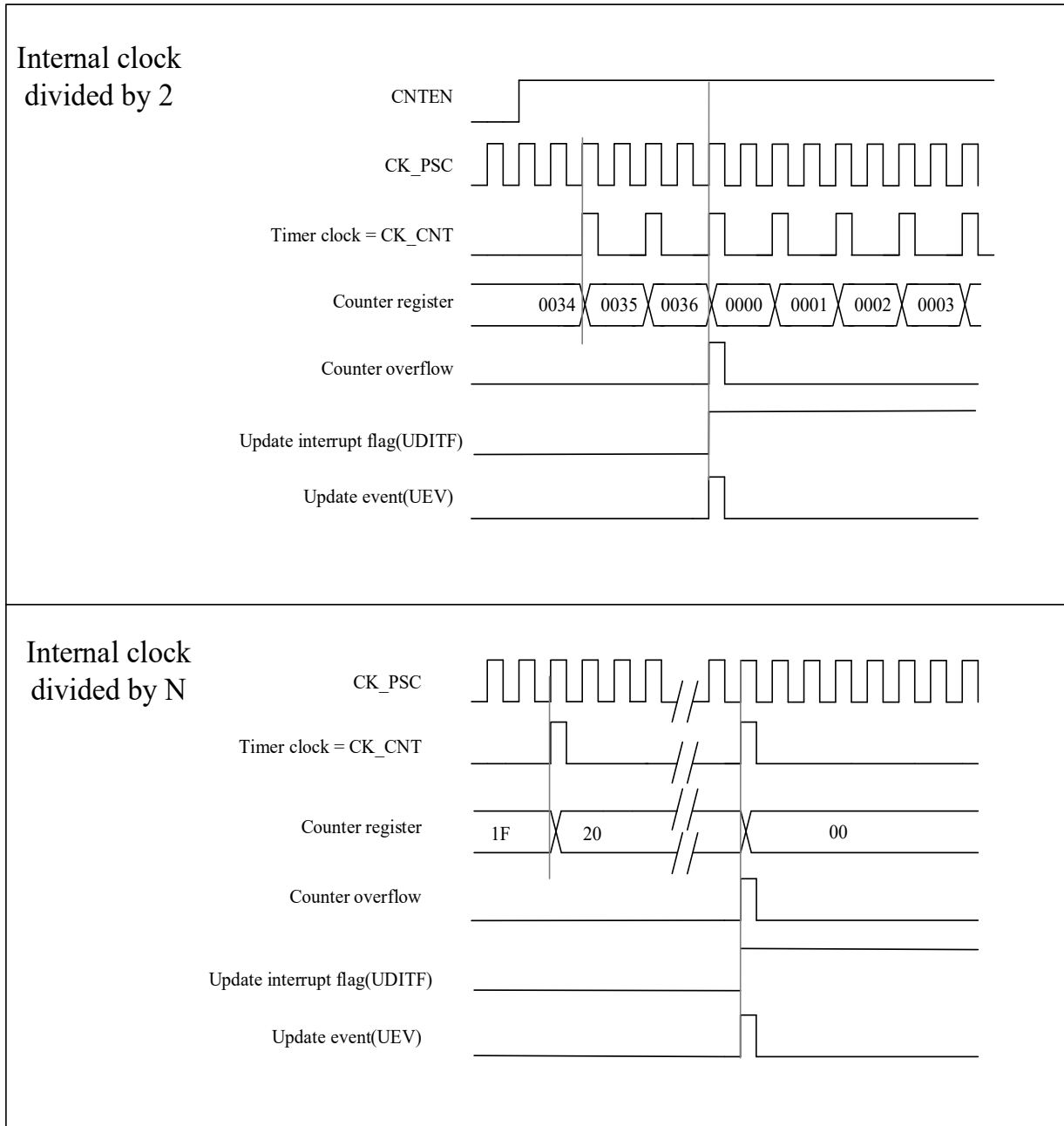
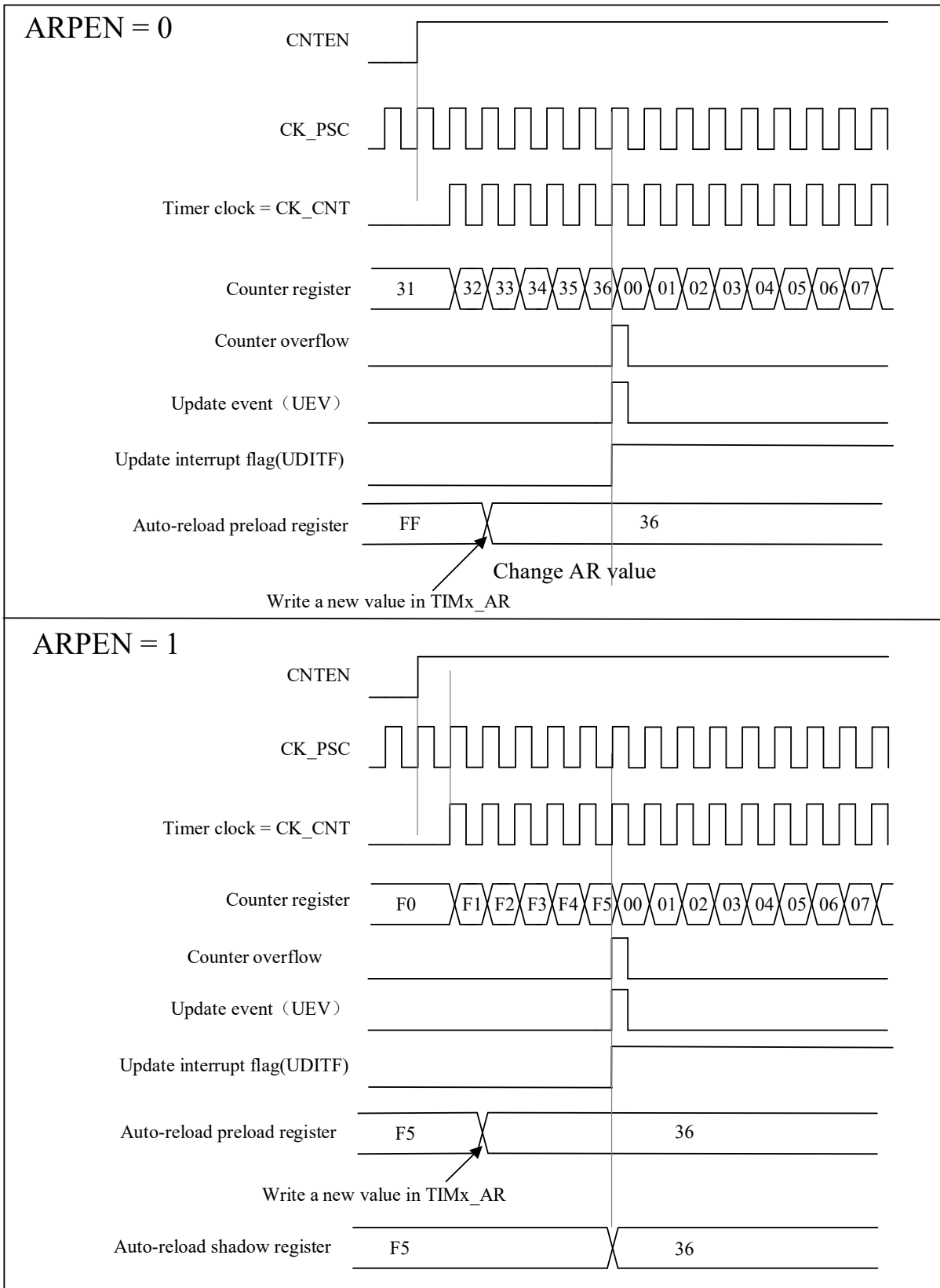


Figure 9-4 Timing Diagram of The Up-counting, Update Event When ARPEN = 0/1



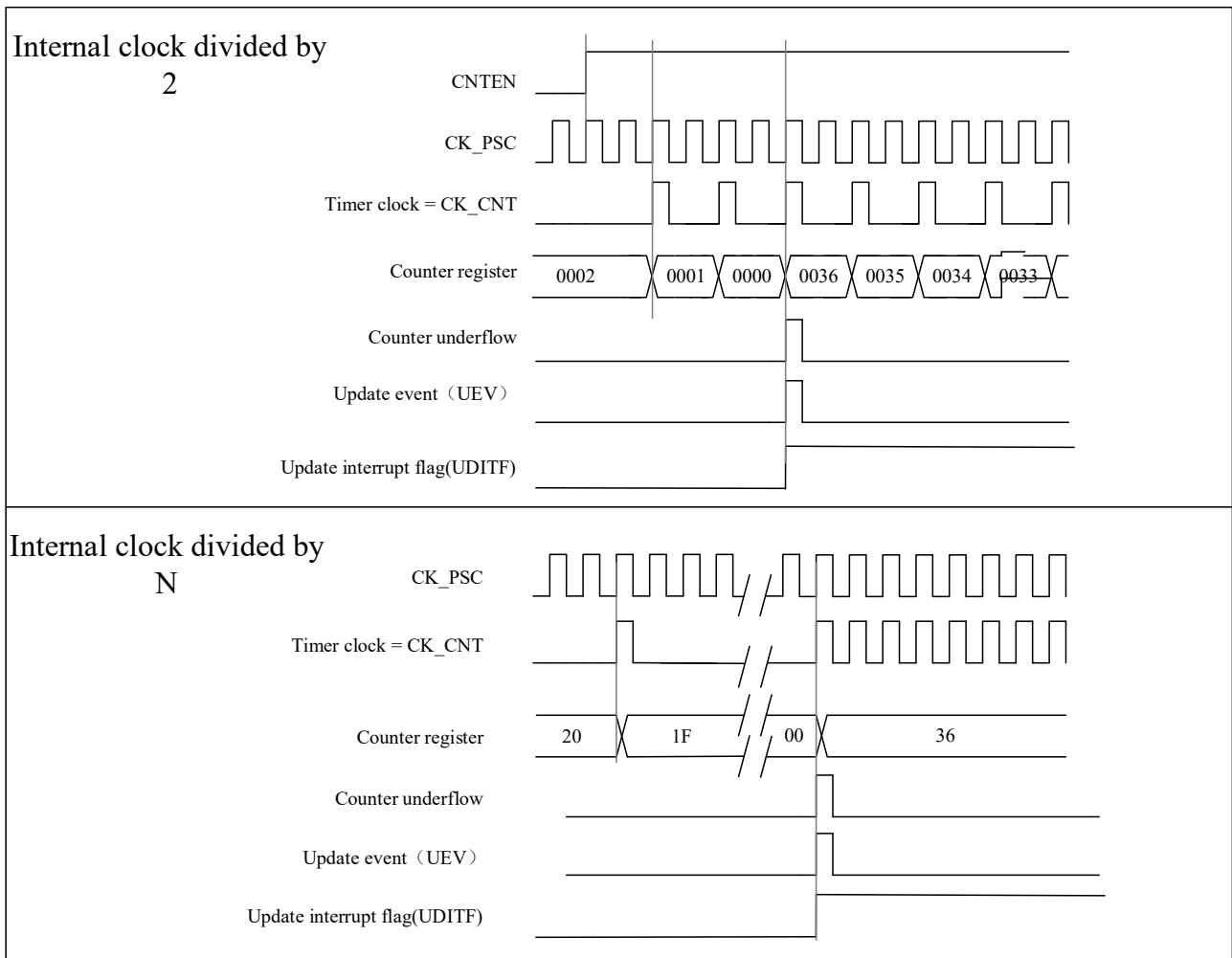
**9.3.2.2 Down-counting mode**

In down-counting mode, the counter will decrement from the value of the register TIMx\_AR to 0, then restart from the auto-reload value and generate a counter underflow event.

The process of configuring update events and updating registers in down-counting mode is the same as in up-counting mode, refer to Section 9.3.2.1.

The figure below shows some examples of the counter behavior and the update flags for different division factors in the down-counting mode.

**Figure 9-5 Timing Diagram of The Down-counting, Internal Clock Divided Factor = 2/N**



**9.3.2.3 Center-aligned mode**

In center-aligned mode, the counter increments from 0 to the value (TIMx\_AR) – 1, a counter overflow event is generated. It then counts down from the auto-reload value (TIMx\_AR) to 1 and generates a counter underflow event. Then the counter resets to 0 and starts counting up again.

In this mode, the TIMx\_CTRL1.DIR direction bits have no effect and the count direction is updated and specified by hardware. Center-aligned mode is active when the TIMx\_CTRL1.CAMSEL bit is not equal to "00".

The update events can be generated each time the counter overflows and each time the counter underflows. Alternatively, an update event can also be generated by setting the TIMx\_EVTGEN. UDGn bit (either by software or using a slave mode controller). In this case, the counter restarts from 0, and the prescaler counter also restarts from 0.

*Note: if an update is generated due to a counter overflow, the auto-reload value will be updated before the counter is reloaded.*

**Figure 9-6 Timing Diagram of The Center-aligned, Internal Clock Divided Factor =2/N**

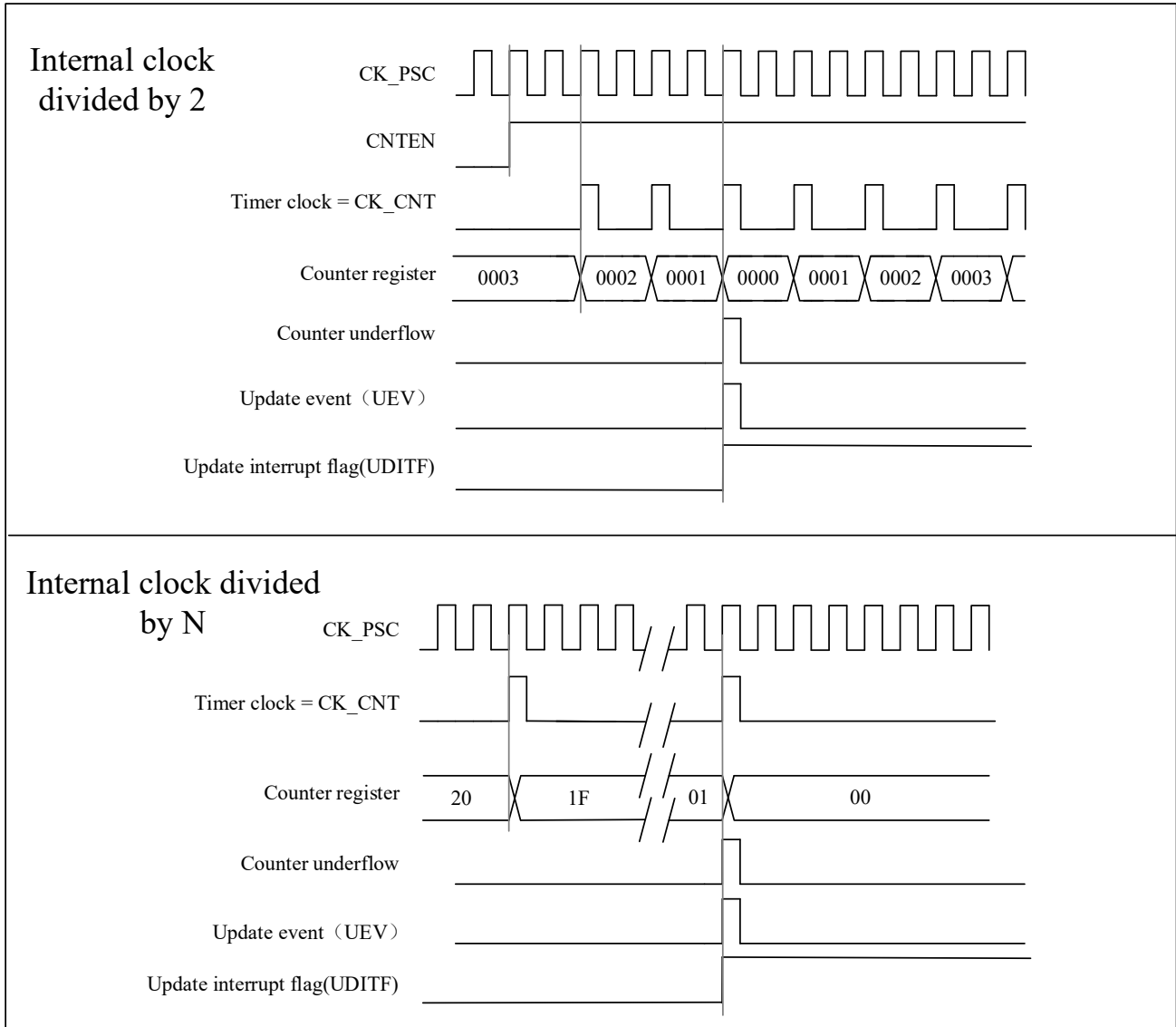
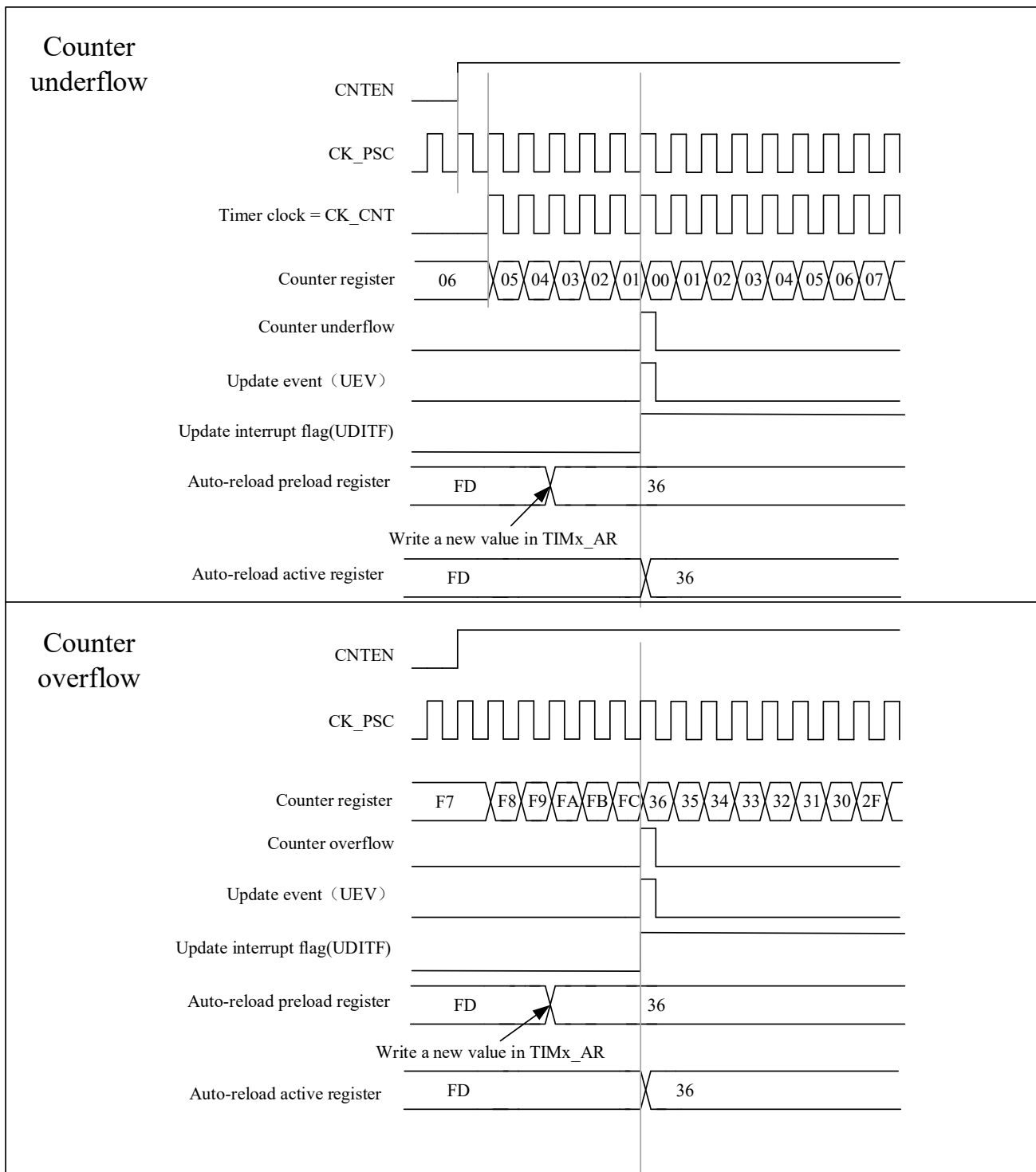


Figure 9-7 A Center-aligned Sequence Diagram That Includes Counter Overflows and Underflows (ARPEN = 1)



### 9.3.3 Repetition Counter

The basic unit of Section 9.3.1 describes the conditions for generating an update event (UEV). An update event (UEV) is actually only generated when the repetition counter reaches zero, which is valuable for generating PWM signals.

This means that data is transferred from the preload registers to the shadow registers every N+1 counter overflow or

underflow, where N is the value in the TIMx\_REPCNT.

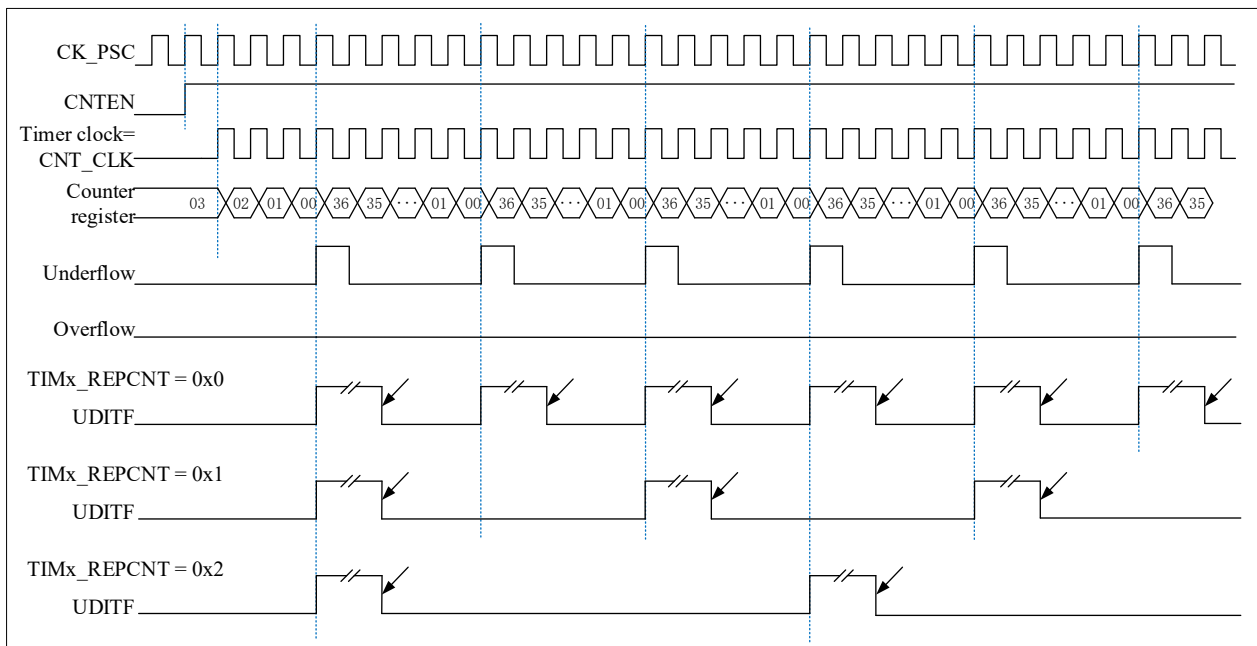
The repetition counter is decremented:

- In the up-counting mode, each time the counter reaches the maximum value, an overflow occurs.
- In down-counting mode, each time the counter decrements to the minimum value, an underflow occurs.
- In center-aligned mode, each time the counter overflows or underflows.

Its repetition rate is set by the value of the TIMx\_REPCNT register.

The repetition counters have an automatic reloading function. The update event ( generated by setting TIMx\_EVTGEN.UDGN or hardware through slave mode controller) occurs immediately, regardless of the value of the repetition counter.

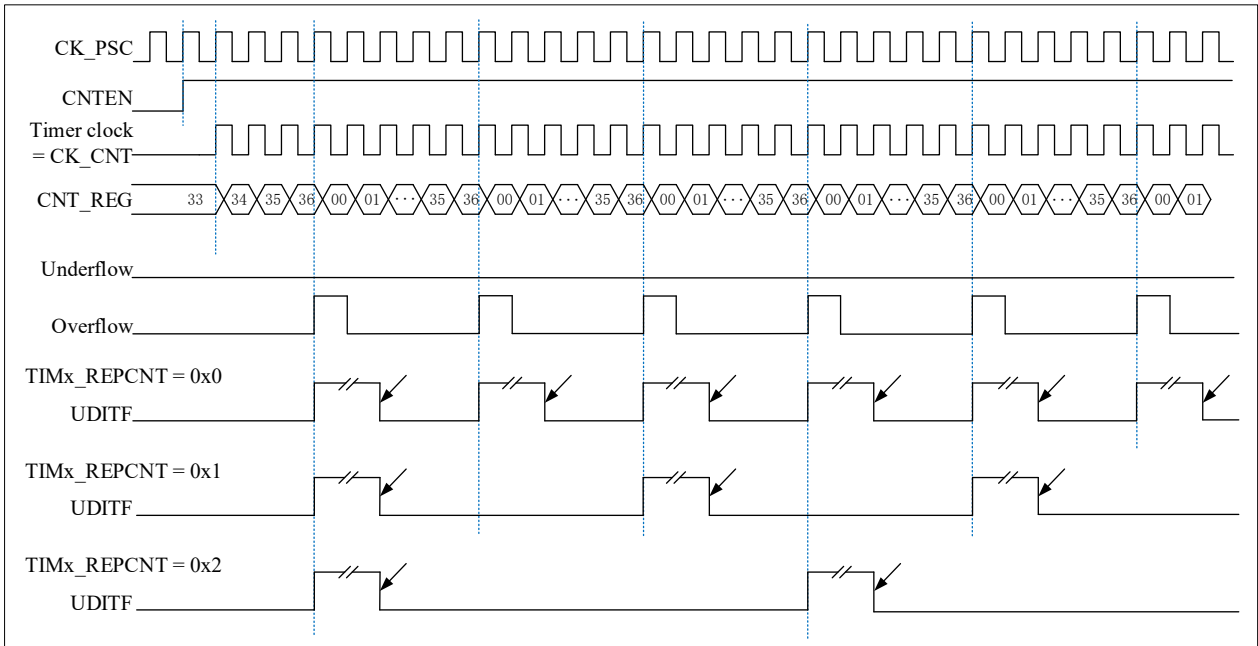
**Figure 9-8 Repeat Count Sequence Diagram in Down-counting Mode**



↙ *Software clear*

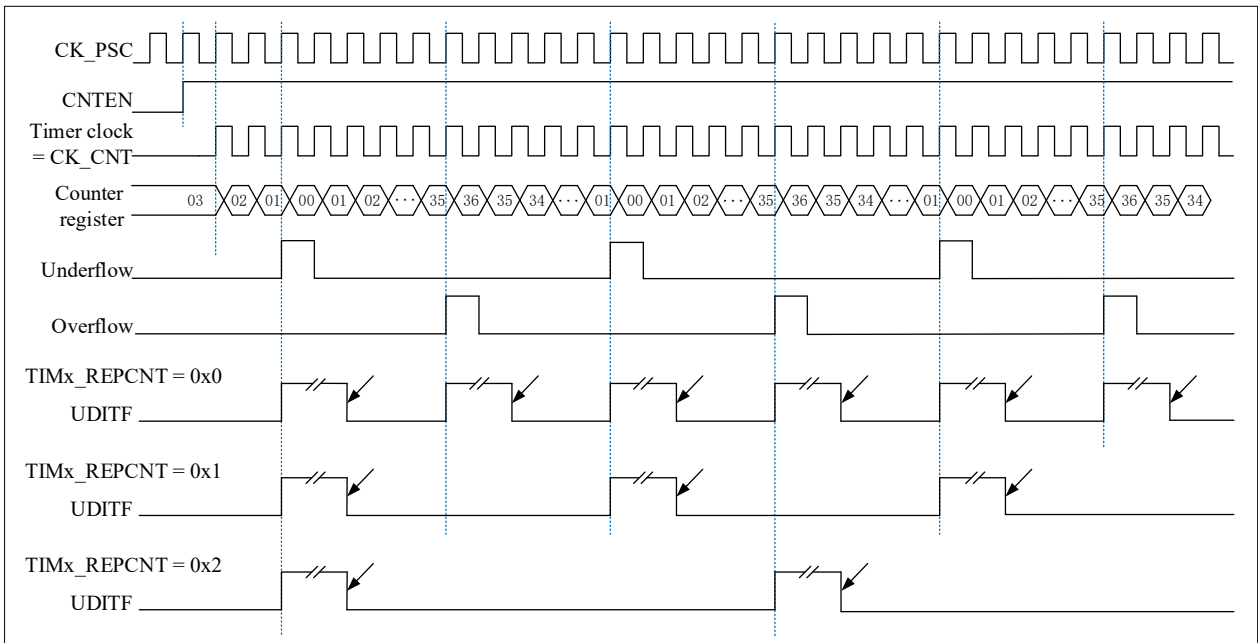


**Figure 9-9 Repeat Count Sequence Diagram in Up-counting Mode**



↙ *Software clear*

**Figure 9-10 Repeat Count Sequence Diagram in Center-aligned Mode**



↙ *Software clear*

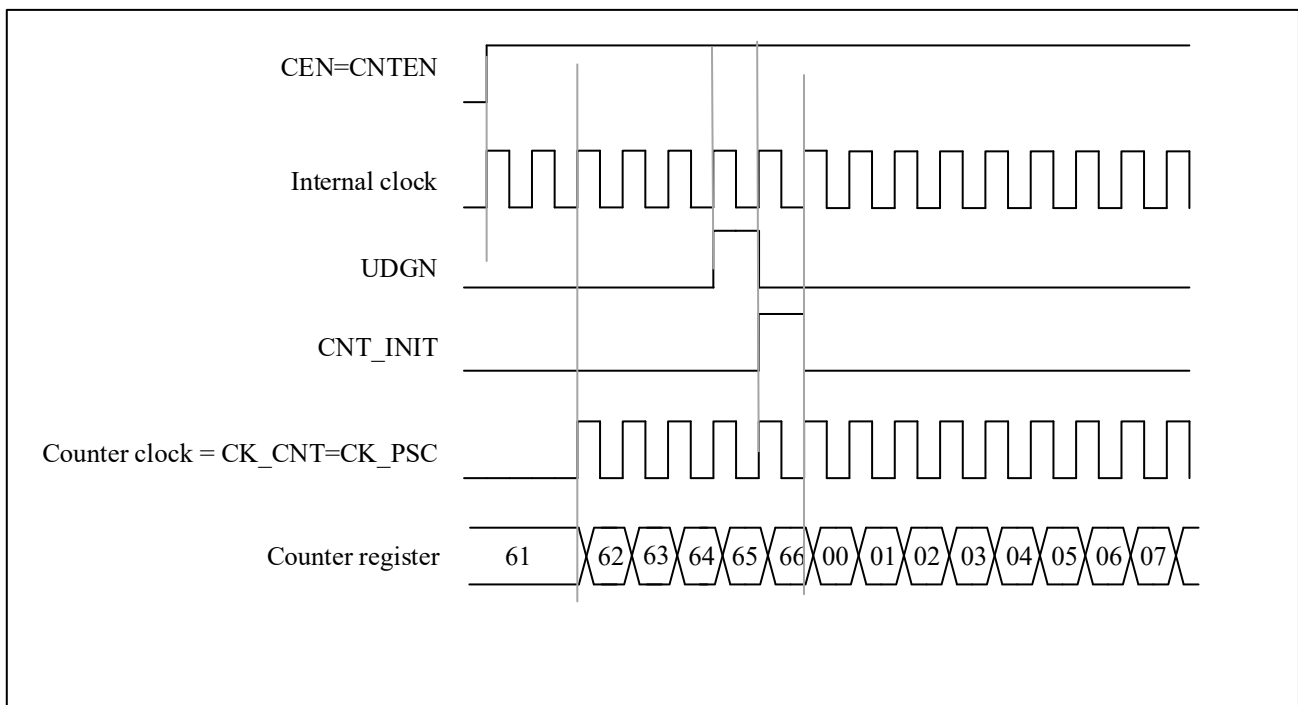
### 9.3.4 Clock Selection

- The internal clock of advanced-control timers : CK\_INT
- Two kinds of external clock mode :
  - external input pin
  - external trigger input ETR
- Internal trigger input (ITRx): one timer is used as a prescaler for another timer.

#### 9.3.4.1 Internal clock source (CK\_INT)

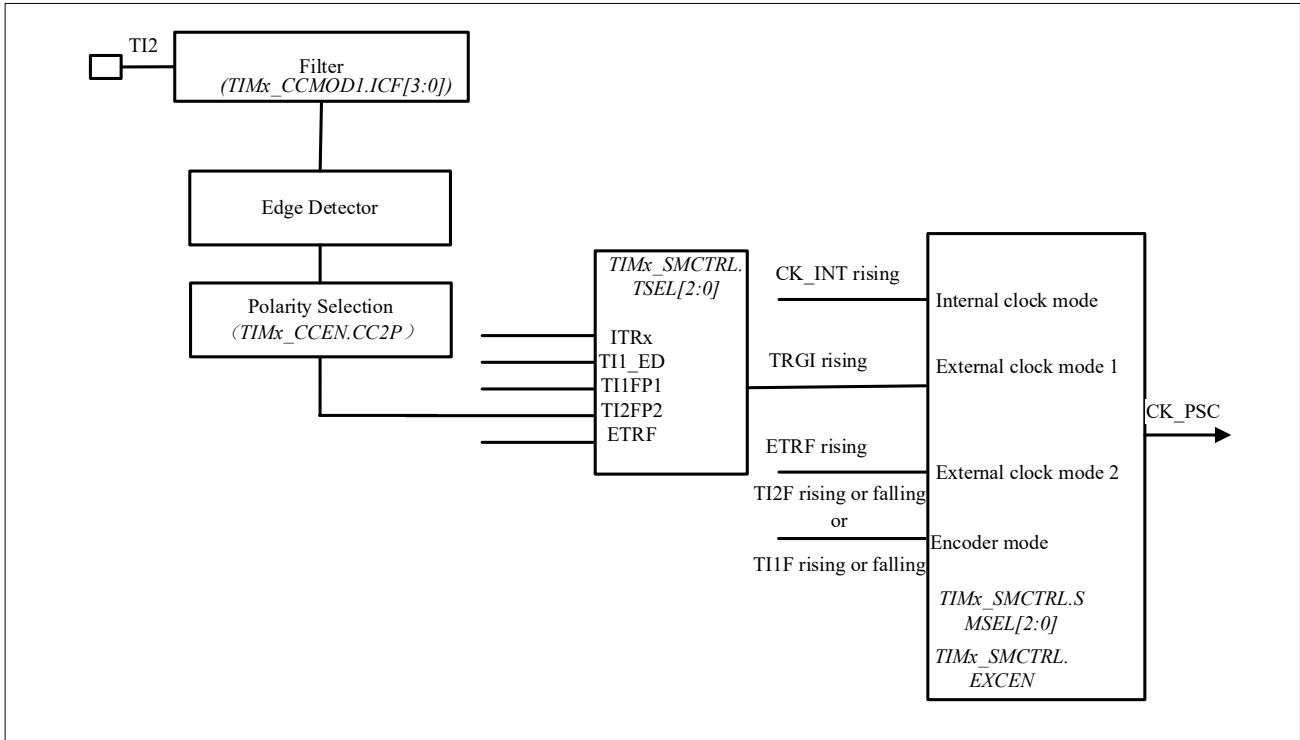
When the TIMx\_SMCTRL.SMSEL is equal to “000”, the slave mode controller is disabled. The three control bits (TIMx\_CTRL1.CNTEN, TIMx\_CTRL1.DIR, TIMx\_EVTGEN.UDGN) can only be changed by software (except TIMx\_EVTGEN.UDGN, which remains cleared automatically). Assuming the TIMx\_CTRL1.CNTEN bit is written as '1' by software, the clock source of the prescaler is provided by the internal clock CK\_INT.

**Figure 9-11 Control Circuit in Normal Mode, Internal Clock Divided By 1**



9.3.4.2 External clock source mode 1

Figure 9-12 TI2 External Clock Connection Example



This mode is selected by configuring `TIMx_SMCTRL.SMSEL=111`. The counter can be configured to count on the rising or falling edge of the clock at the selected input.

For example, to configure up-counting mode to count on the rising edge of the clock at the TI2 input, the configuration steps are as follows:

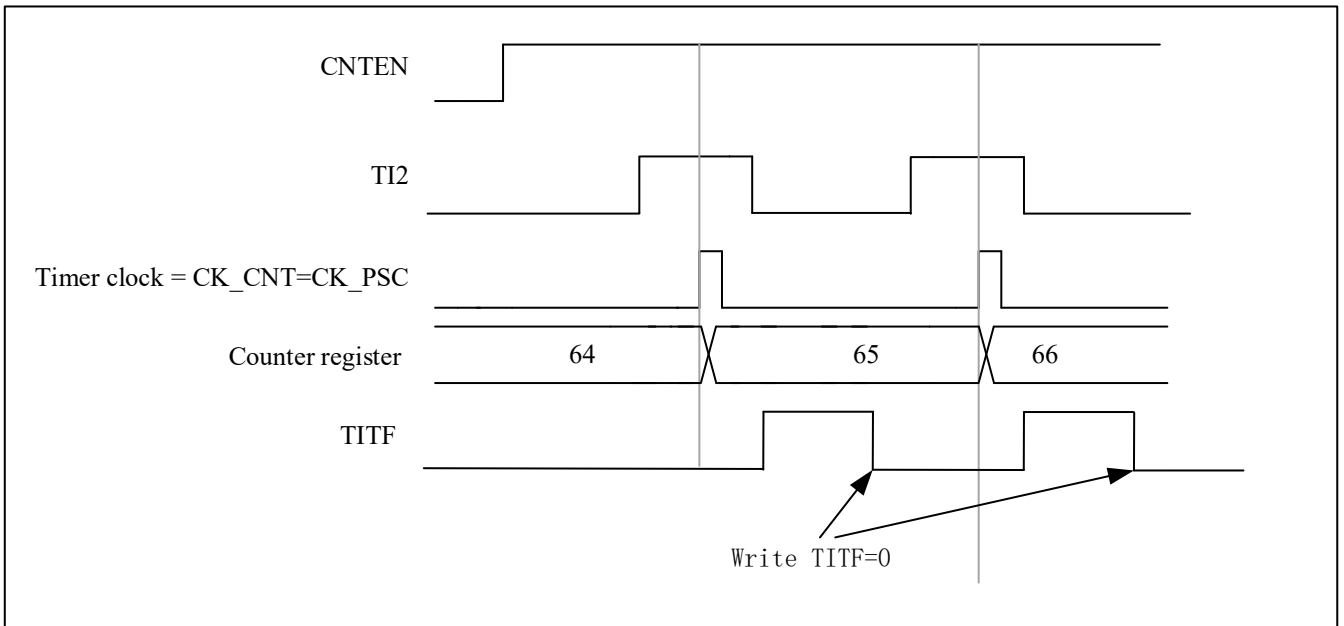
- Configure `TIMx_CCMOD1.CC2SEL` equal to '01', CC2 channel is configured as input, IC2 is mapped to TI2
- Configure `TIMx_CCEN.CC2P` equal to '0', select clock rising edge polarity
- To select input filter bandwidth by configuring `TIMx_CCMOD1.IC2F[3:0]` (if filter is not needed, keep IC2F bit at '0000')
- Configure `TIMx_SMCTRL.SMSEL` equal to '111', select timer external clock mode 1
- Configure `TIMx_SMCTRL.TSEL` equal to '110', select TI2 as the trigger input source
- Configure `TIMx_CTRL1.CNTEN` equal to '1' to start the counter

*Note: The capture prescaler is not used for triggering, so it does not need to be configured*

When the rising edge of the timer clock occurs at `TI2=1`, the counter counts once and the `TIMx_STS.TITF` flag is set.

The delay between the rising edge of TI2 and the actual clock of the counter depends on the resynchronization circuit at the input of TI2.

Figure 9-13 Control Circuit in External Clock Mode 1

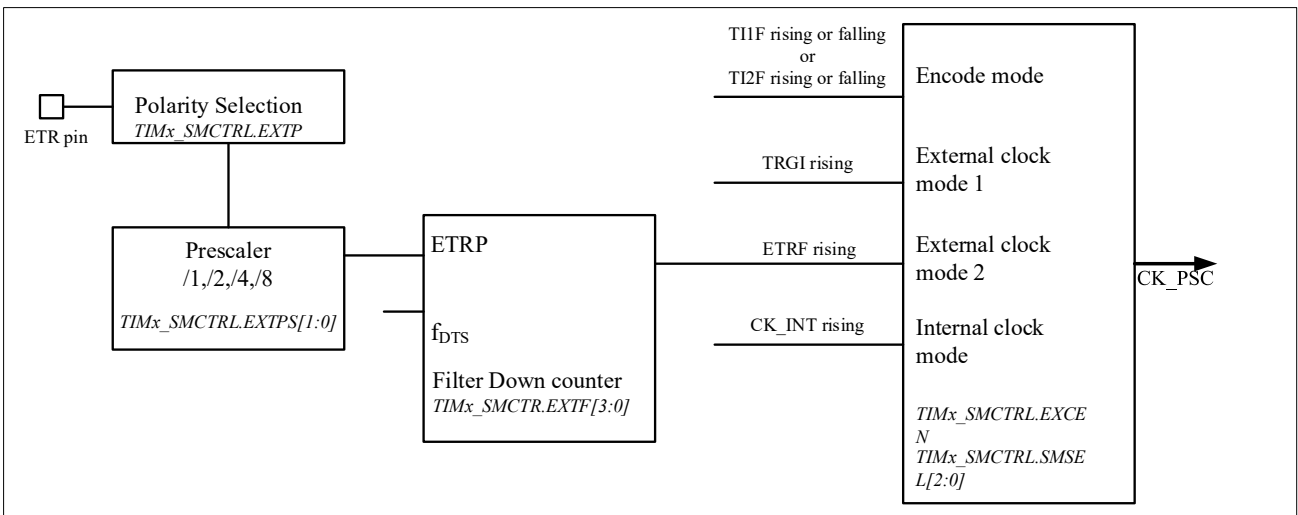


9.3.4.3 External clock source mode 2

This mode is selected by TIMx\_SMCTRL .EXCEN equal to 1. The counter can count on every rising or falling edge of the external trigger input ETR.

The following figure is a schematic diagram of the external trigger input module of the external clock source mode 2

Figure 9-14 External Trigger Input Block Diagram



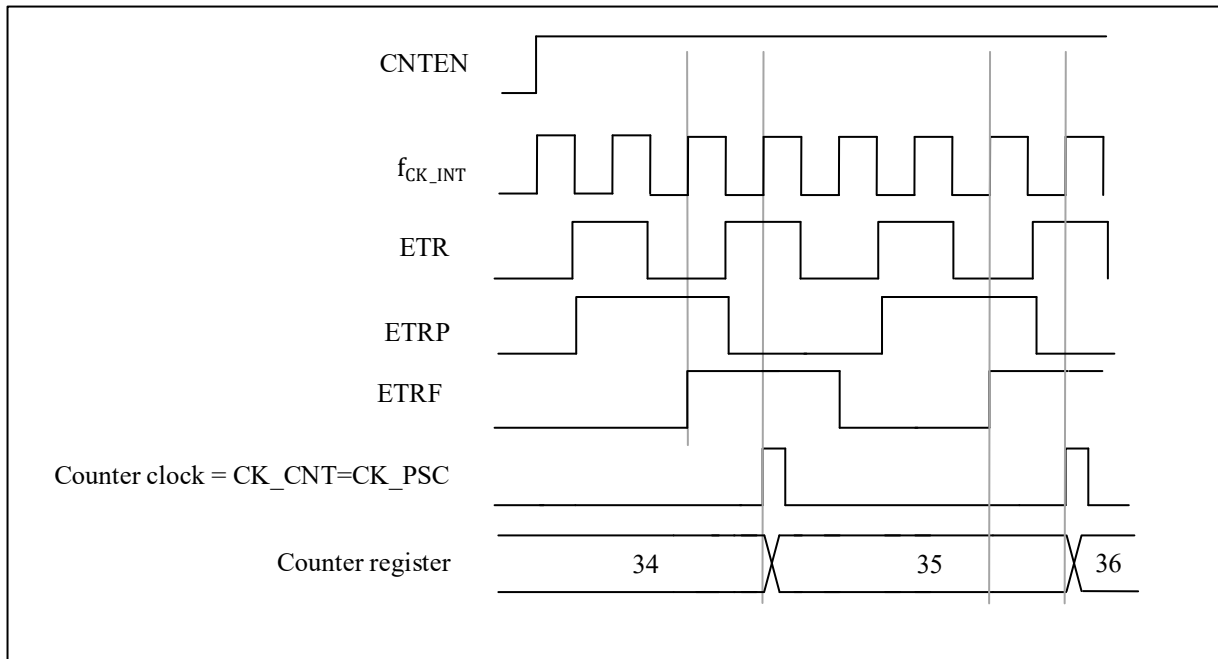
For example, use the following configuration steps to make the up counter count every 2 rising edges on ETR.

- Since no filter is required in this case, set TIMx\_SMCTRL .EXTF[3:0] equal to '0000'
- Configure the prescaler by setting TIMx\_SMCTRL.EXTPS[1:0] equal to '01'
- Select the polarity on ETR pin by setting TIMx\_SMCTRL.EXTP equal to '0', the rising edge of ETR is valid

- External clock mode 2 is selected by setting TIMx\_SMCTRL .EXCEN equal to '1'
- Turn on the counter by setting TIMx\_CTRL1. CNTEN equal to '1'

The counter counts every 2 rising edges of ETR. The delay between the rising edge of ETR and the actual clock to the counter is due to a resynchronization circuit on the ETRP signal.

**Figure 9-15 Control Circuit in External Clock Mode 2**

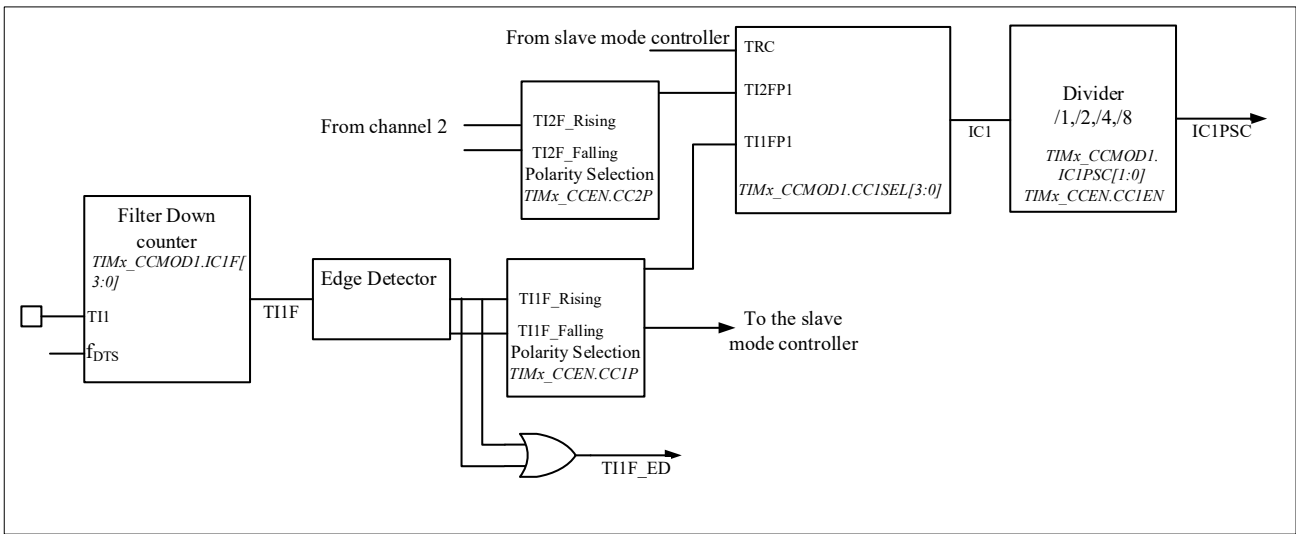


### 9.3.5 Capture/Compare Channels

The capture/compare channels include capture/compare registers and shadow registers. The input stage consists of digital filters, multiplexers and prescalers. The output section includes comparators and output controls.

The input signal T<sub>ix</sub> is sampled and filtered to generate the signal T<sub>ixF</sub>. Then, the edge detector of the polarity selection function generates signals (T<sub>ixF\_rising</sub> or T<sub>ixF\_falling</sub>), whose polarity is selected by the TIMx\_CCEN.CCxP bit. This signal can be used as a trigger input for the slave mode controller. At the same time, the signal IC<sub>x</sub> is sent to the capture register after frequency division. The following figure shows a block diagram of a capture/compare channel.

Figure 9-16 Capture/Compare Channel (Example: Channel 1 Input Stage)



The output stage generates an intermediate waveform OCxRef (high level active) as reference. The polarity acts at the end of the chain.

Figure 9-17 Capture/Compare Channel 1 Main Circuit

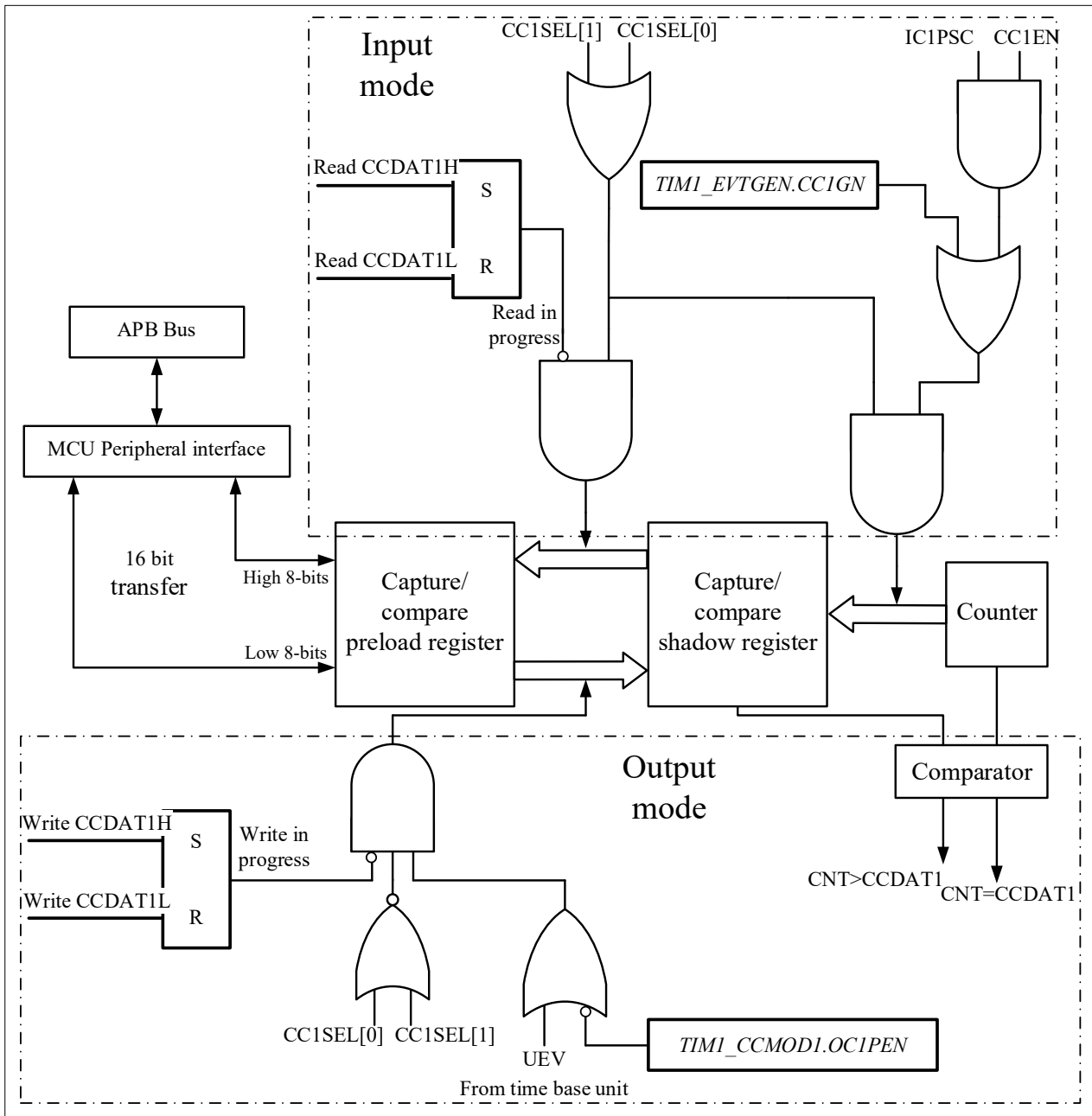


Figure 9-18 Output Part of Channelx (x= 1,2,3, Take Channel 1 As Example)

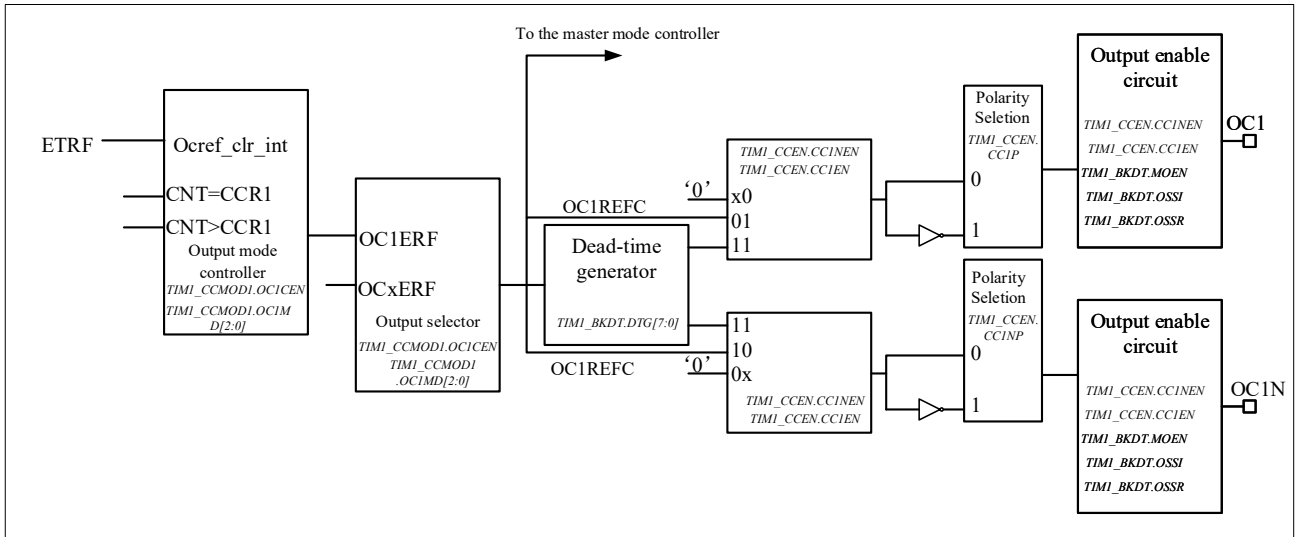
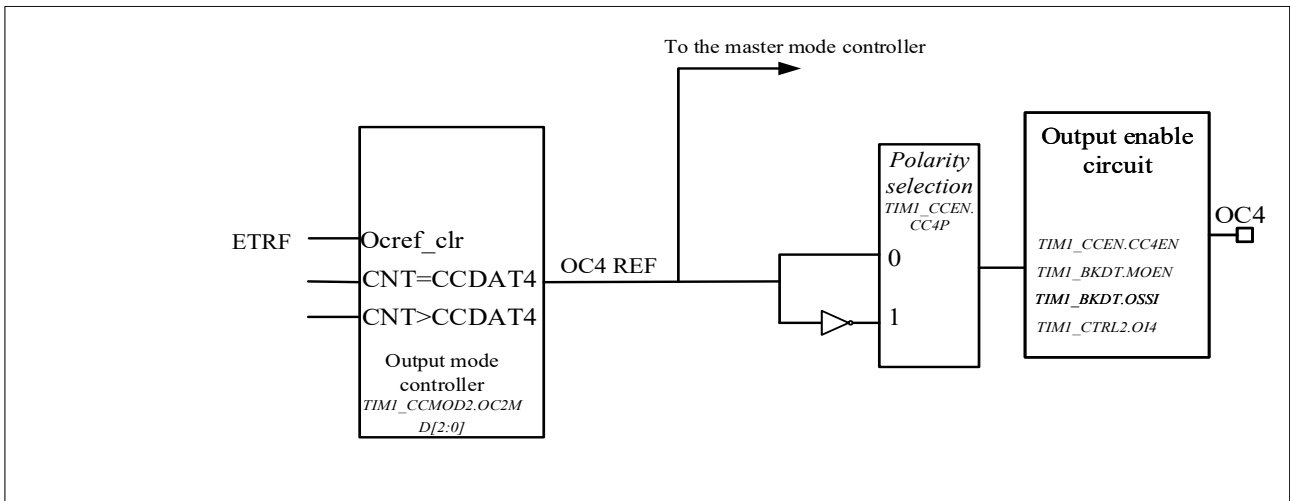


Figure 9-19 Output Part of Channelx (x= 4)



Reads and writes always access the preload registers when capturing/comparing. The two specific operating processes are as follows:

In capture mode, the capture is actually done in the shadow register, and then the value in the shadow register is copied into the preload register.

In compare mode, the value of the preload register is copied into the shadow register, which is compared with the counter.

### 9.3.6 Input Capture Mode

In input capture mode, the TIMx\_CCxDATx registers are used to latch the counter value after the ICx signal detects.

There is a capture interrupt flag TIMx\_STS.CCxITF, which can trigger an interrupt or DMA request if the corresponding interrupt enable is pulled high.

The TIMx\_STS.CCxITF bit is set by hardware when a capture event occurs and is cleared by software or by reading the TIMx\_CCxDATx register.



The overcapture flag `TIMx_STS.CCxOCF` is set equal to 1 when the counter value is captured in the `TIMx_CCDA Tx` register and `TIMx_STS.CC1ITF` is already pulled high. Unlike the former, `TIMx_STS.CCxOCF` is cleared by writing 0.

To capture the counter value at the rising edge of the `TI1` input into the `TIMx_CCDA T1` register, the configuration flow is as follows:

- To select a valid input:  
Configure `TIMx_CCMOD1.CC1SEL` to '01'. At this time, the input is the `CC1` channel, and `IC1` is mapped to `TI1`.
- Define the input filter duration required for programming:  
Set the sampling frequency of the `TI1` input and the length of the digital filter by configuring the `TIMx_CCMODx.ICxF` bits. Example: if the input signal has jitter of up to 5 internal clock cycles, we must choose a filter duration longer than these 5 clock cycles. When 8 consecutive samples (sampled at  $f_{DTS}$  frequency) with the new level are detected, we can validate the transition on `TI1`. Then configure `TIMx_CCMOD1.IC1F` to '0011'.
- Select the rising edge as the valid transition polarity on the `TI1` channel by configuring `TIMx_CCEN.CC1P=0`.
- Configure the input prescaler. In this example, configure `TIMx_CCMOD1.IC1PSC= '00'` to disable the prescaler because we want to capture every valid transition.
- Enable capture by configuring `TIMx_CCEN.CC1EN = '1'`.

If you want to enable DMA request, you can configure `TIMx_DINTEN.CC1DEN=1`. If you want enable related interrupt request, you can configure `TIMx_DINTEN.CC1IEN bit=1`

### 9.3.7 PWM Input Mode

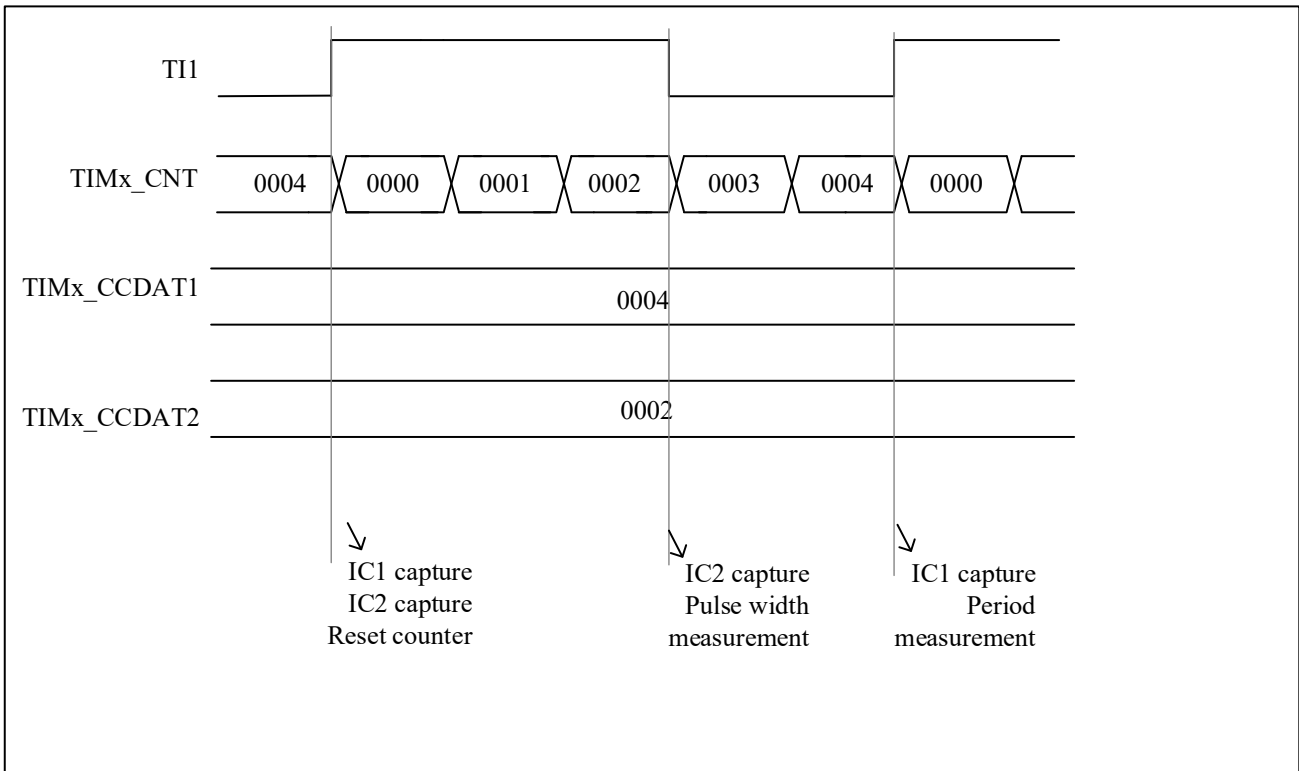
There are some differences between PWM input mode and normal input capture mode, including:

- Two `ICx` signals are mapped to the same `TIx` input.
- The two `ICx` signals are active on edges of opposite polarity.
- Select one of two `TIxFP` signals as trigger input.
- The slave mode controller is configured in reset mode.

For example, the following configuration flow can be used to get the period and duty cycle of the PWM signal on `TI1` (It depends on the frequency of `CK_INT` and the value of the prescaler).

- Configure `TIMx_CCMOD1.CC1SEL` equal to '01' to select `TI1` as valid input for `TIMx_CCDA T1`.
- Configure `TIMx_CCEN.CC1P` equal to '0' to select the polarity of filtered timer input 1 (`TI1FP1`), active at the rising edge.
- Configure `TIMx_CCMOD1.CC2SEL` equal to '10' select `TI1` as valid input for `TIMx_CCDA T2`.
- Configure `TIMx_CCEN.CC2P` equal to 1 to select the valid polarity of filtered timer input 2 (`TI1FP2`), active at the falling edge.
- Configure `TIMx_SMCTRL.TSEL=101` to select Filtered timer input 1 (`TI1FP1`) as valid trigger input.
- Configure `TIMx_SMCTRL.SMSEL=100` to configure the slave mode controller to reset mode.
- Configure `TIMx_CCEN.CC1EN=1` and `TIMx_CCEN.CC2EN=1` to enable capture.

Figure 9-20 PWM Input Mode Timing



Because of only filter timer input 1 (TI1FP1) and filter timer input 2 (TI2FP2) are connected to the slave mode controller, the PWM input mode can only be used with the TIMx\_CH1/TIMx\_CH2 signals.

### 9.3.8 Forced Output Mode

User can force output compare signals to active or inactive level directly in output mode (TIMx\_CCMODx.CCxSEL=00) by software.

User can set TIMx\_CCMODx.OCxMD=101 to force the output compare signal to active level. And the OCxREF will be forced high, OCx get opposite value to CCxP polarity bit. On the other hand, user can set TIMx\_CCMODx.OCxMD=100 to force the output compare signal to low level.

The values of the TIMx\_CCDATx shadow register and the counter still comparing with each other in this mode.

The comparison between the output compare register TIMx\_CCDATx and the counter TIMx\_CNT has no effect on OCxREF. And the flag still can be set. Therefore, the interrupt and DMA requests still can be sent.

### 9.3.9 Output Compare Mode

User can use this mode to control the output waveform, or to indicate that a period of time has elapsed.

When the capture/compare register and the counter have the same value, the output compare function's operations are as follow:

- TIMx\_CCMODx.OCxMD is for output compare mode, and TIMx\_CCEN.CCxP is for output polarity. When the compare matches, if set TIMx\_CCMODx.OCxMD=000, the output pin will keep its level; if set TIMx\_CCMODx.OCxMD=001, the output pin will be set active; if set TIMx\_CCMODx.OCxMD=010, the output

pin will be set inactive; if set TIMx\_CCMODx.OCxMD=011, the output pin will be set to toggle.

- Set TIMx\_STS.CCxITF.
- If user set TIMx\_DINTEN.CCxIEN, a corresponding interrupt will be generated.
- If user set TIMx\_DINTEN.CCxDEN and set TIMx\_CTRL2.CCDSEL to select DMA request, and DMA request will be sent.

User can set TIMx\_CCMODx.OCxPEN to choose capture/compare shadow register using capture/compare preload registers(TIMx\_CCDA Tx) or not.

The time resolution is one count of the counter.

In one-pulse mode, the output compare mode can also be used to output a single pulse.

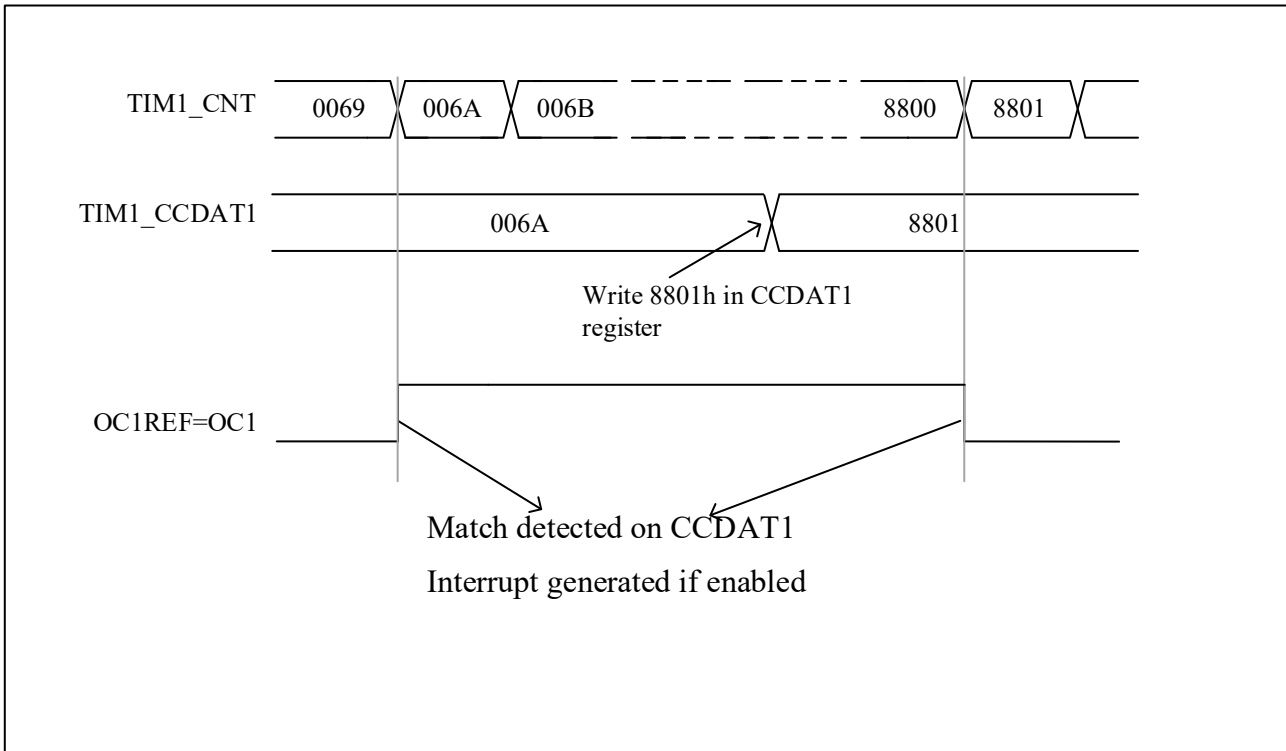
Here are the configuration steps for output compare mode:

- First of all, user should select the counter clock.
- Secondly, set TIMx\_AR and TIMx\_CCDA Tx with desired data.
- If user need to generate an interrupt, set TIMx\_DINTEN.CCxIEN.
- Then select the output mode by set TIMx\_CCEN.CCxP, TIMx\_CCMODx.OCxMD, TIMx\_CCEN.CCxEN, etc.
- At last, set TIMx\_CTRL1.CNTEN to enable the counter.

User can update the output waveform by setting TIMx\_CCDA Tx at any time, as long as the preload register is not enabled. Otherwise the TIMx\_CCDA Tx shadow register will be updated at the next update event.

Here is an example.

Figure 9-21 Output Compare Mode, Toggle on OC1



### 9.3.10 PWM Mode

User can get a signal whose duty cycle is determined by the value of the TIMx\_CCDAx register and whose frequency is determined by the value of the TIMx\_AR register in PWM mode. And depends on the value of TIMx\_CTRL1.CAMSEL, the TIM can generate PWM signal in edge-aligned mode or center-aligned mode.

User can set PWM mode 1 or PWM mode 2 by setting TIMx\_CCMODx. OCxMD=110 or setting TIMx\_CCMODx. OCxMD=111. To enable preload register, user must set corresponding TIMx\_CCMODx.OCxPEN. And then set TIMx\_CTRL1.ARPEN to auto-reload preload register eventually.

User can set polarity of OCx by setting TIMx\_CCEN.CCxP. On the other hand, to enable the output of OCx, user need to set the combination of the value of OSS1 and OSSR, CCxEN, CCxNEN, and MOEN in TIMx\_CCEN and TIMx\_BKDT.

The values of TIMx\_CNT and TIMx\_CCDAx are always compared with each other when the TIM is under PWM mode.

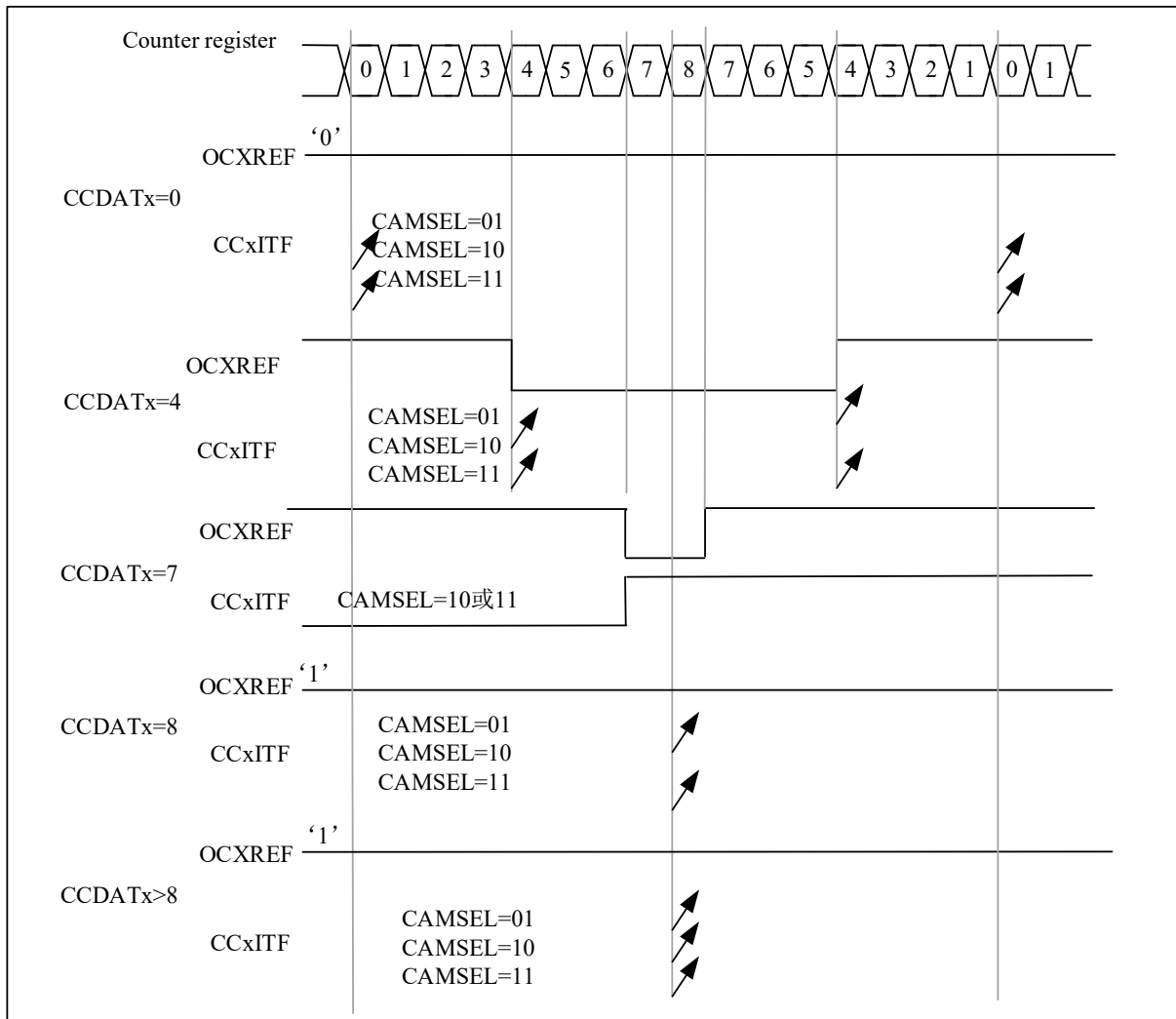
Only when an update event occurs, the preload register will be transferred to the shadow register. Therefore user must reset all the registers by setting TIMx\_EVTGEN.UDGN before the counter starts counting..

#### 9.3.10.1 PWM center-aligned mode

If user set TIMx\_CTRL1.CAMSEL equal 01, 10 or 11, the PWM center-aligned mode will be active. The setting of the compare flag depends on the value of TIMx\_CTRL1.CAMSEL. There are three kinds of situation that the compare flag is set, only when the counter counts up, only when the counter counts down, or both when the counter counts up and counts down. User should not modified TIMx\_CTRL1.DIR by software, it is updated by hardware.

Examples of center-aligned PWM waveforms is as follow, and the setting of the waveform are: TIMx\_AR=8, PWM mode 1, the compare flag is set when the counter counts down corresponding to TIMx\_CTRL1. CAMSEL=01.

Figure 9-22 Center-aligned PWM Waveform (AR=8)



When using center-aligned mode, users should pay attention to the following considerations:

- It depends on the value of TIMx\_CTRL1.DIR that the counter counts up or down. Caution that the DIR and CAMSEL bits should not be changed at the same time.
- User should not write the counter while running in center-aligned mode, otherwise it will cause unexpected results. Here are some examples:
  - If the value written into the counter is 0 or is the value of TIMx\_AR, the direction will be updated but the update event will not be generated.
  - If the value written into the counter is greater than the value of auto-reload, the direction will not be updated.
- For safety reasons, it is recommended that users set TIMx\_EVTGEN.UDGN to generate an update by software before starting the counter, and not writing the counter while it is running.

### 9.3.10.2 PWM edge-aligned mode

There are two kinds of configuration in edge-aligned mode, up-counting and down-counting.

- **Up-counting**

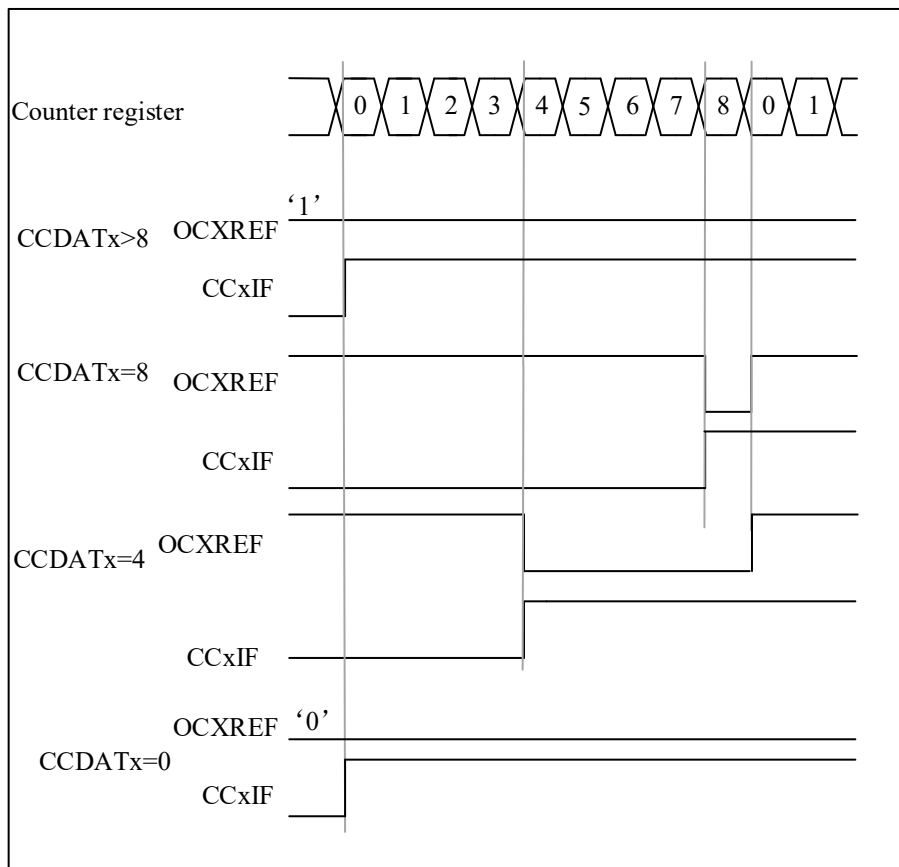
User can set `TIMx_CTRL1.DIR=0` to make counter counts up.

Example for PWM model.

When `TIMx_CNT < TIMx_CCxDATx`, the `OCxREF` is high level, otherwise it will be low level. If the compare value in `TIMx_CCxDATx` is greater than the auto-reload value, the `OCxREF` will remains 1. Conversely, if the compare value is 0, the `OCxREF` will remains 0.

When `TIMx_AR=8`, the PWM waveforms are as follow.

**Figure 9-23 Edge-aligned PWM Waveform (APR=8)**



- **Down-counting**

User can set `TIMx_CTRL1.DIR=1` to make counter counts down.

Example for PWM model.

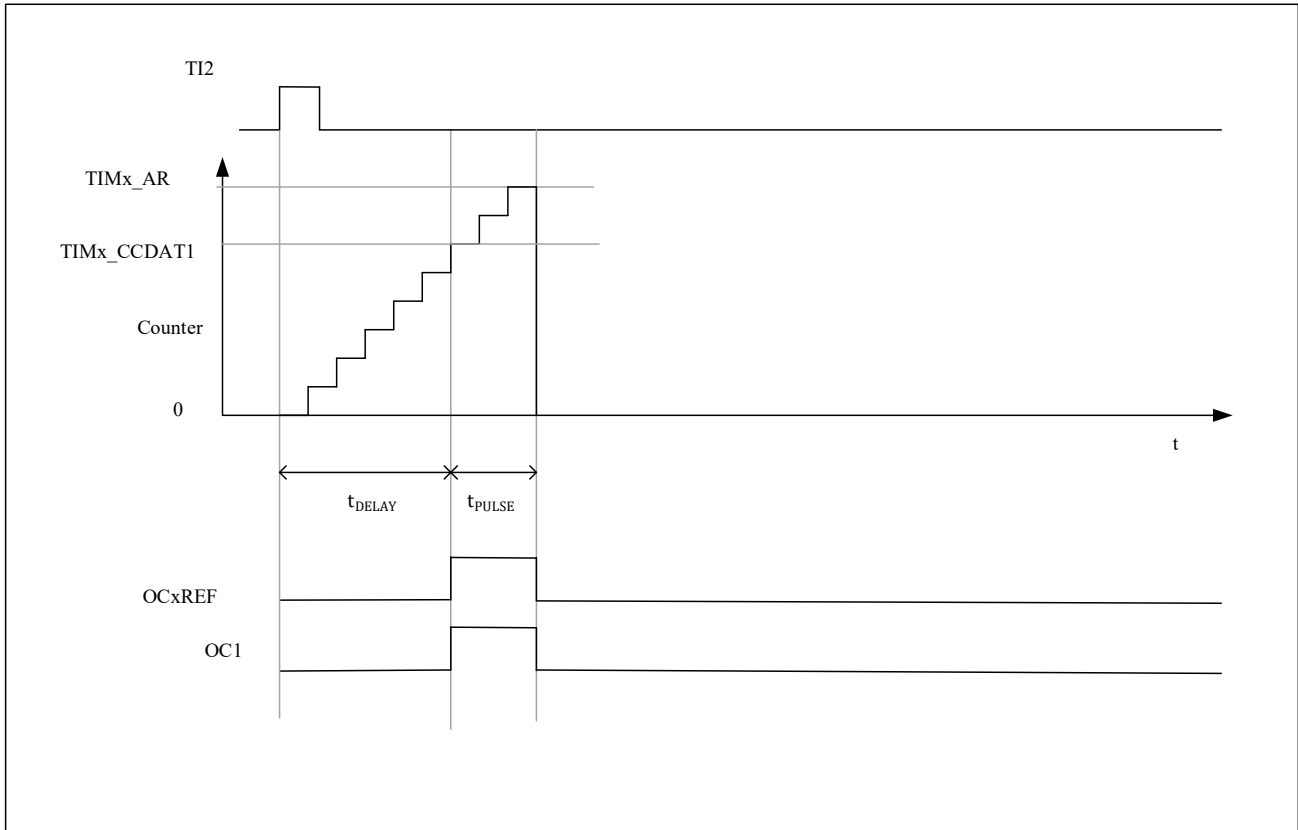
When `TIMx_CNT > TIMx_CCxDATx`, the `OCxREF` is low level, otherwise it will be high level. If the compare value in `TIMx_CCxDATx` is greater than the auto-reload value, the `OCxREF` will remains 1.

*Note: If the  $n$ th PWM cycle `CCDATx` shadow register  $\geq$  `AR` value, the shadow register value of `CCDATx` in the  $(n+1)$ th PWM cycle is 0. At the moment when the counter is 0 in the  $(n+1)$ th PWM cycle, although the value of the counter = `CCDATx` shadow register = 0 and `OCxREF` = '0', no compare event will be generated.*

### 9.3.11 One-pulse Mode

In the one-pulse mode (ONEPM), a trigger signal is received, and a pulse  $t_{PULSE}$  with a controllable pulse width is generated after a controllable delay  $t_{DELAY}$ . The output mode needs to be configured as output compare mode or PWM mode. After selecting one-pulse mode, the counter will stop counting after the update event UEV is generated.

Figure 9-24 Example of One-pulse Mode



The following is an example of a one-pulse mode:

A rising edge trigger is detected from the TI2 input, and a pulse with a width of  $t_{PULSE}$  is generated on OC1 after a delay of  $t_{DELAY}$ .

1. Counter configuration: count up, counter  $TIMx\_CNT < TIMx\_CCDAT1 \leq TIMx\_AR$ ;
2. TI2FP2 is mapped to TI2,  $TIMx\_CCMOD1.CC2SEL = '01'$ ; TI2FP2 is configured for rising edge detection,  $TIMx\_CCEN.CC2P = '0'$ ;
3. TI2FP2 acts as the trigger (TRGI) of the slave mode controller and starts the counter,  $TIMx\_SMCTRL.TSEL = '110'$ ,  $TIMx\_SMCTRL.SMSEL = '110'$  (trigger mode);
4.  $TIMx\_CCDAT1$  writes the count value to be delayed ( $t_{DELAY}$ ),  $TIMx\_AR - TIMx\_CCDAT1$  is the count value of the pulse width  $t_{PULSE}$ ;
5. Configure  $TIMx\_CTRL1.ONEPM = 1$  to enable single pulse mode, configure  $TIMx\_CCMOD1.OC1MD = '111'$  to select PWM2 mode;

6. Wait for an external trigger event on TI2, and a one pulse waveform will be output on OC1;

**9.3.11.1 Special case: OCx fast enable:**

In one-pulse mode, an edge is detected through the TIX input, and triggers the start of the counter to count to the comparison value and then output a pulse. These operations limit the minimum delay  $t_{DELAY}$ .

You can set `TIMx_CCMODx.OCxFEN=1` to turn on OCx fast enable, after triggering the rising edge, the OCxREF signal will be forced to be converted to the same level as the comparison match occurs immediately, regardless of the comparison result. OCxFEN fast enable only takes effect when the channel mode is configured as PWM1 and PWM2 modes.

**9.3.11.2 Clearing The Ocxref Signal on An External Event**

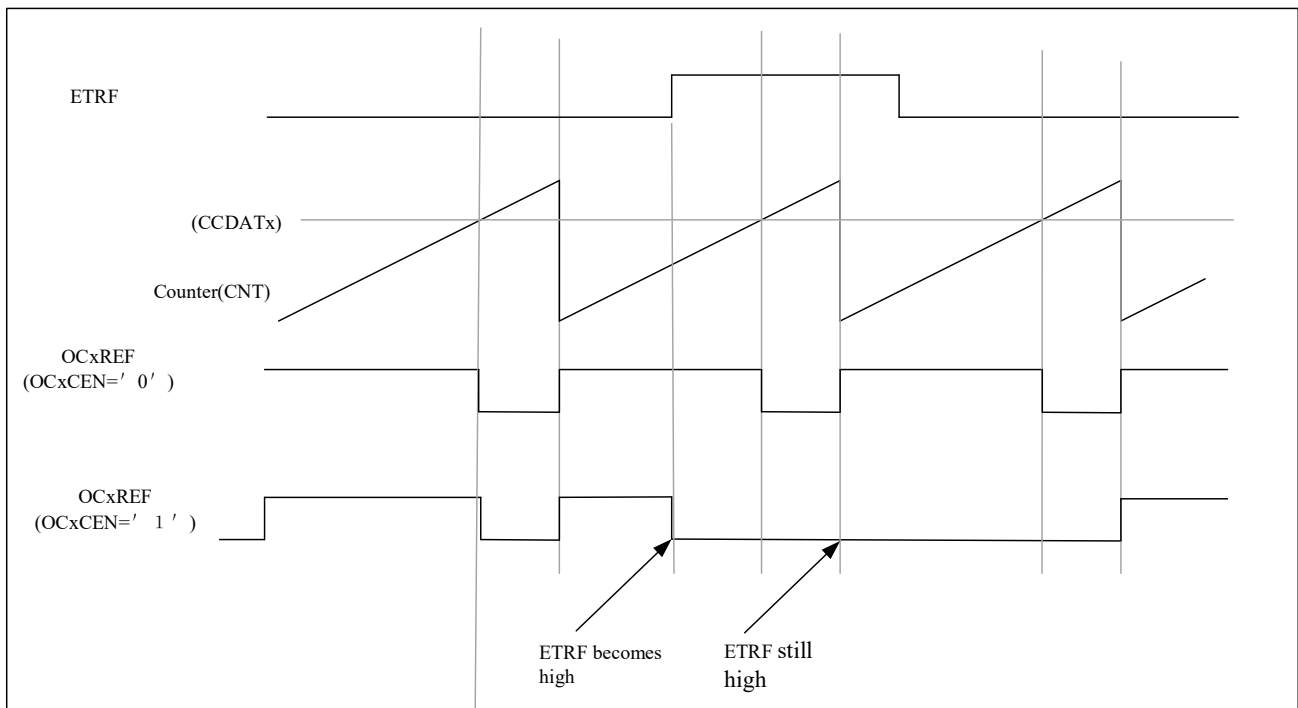
If the user sets `TIMx_CCMODx.OCxCEN=1`, high level of ETRF input can be used to driven the OCxREF signal to low, and the OCxREF signal will remains low, until the next UEV happens. Only in output compare mode and PWM modes this function can be used. This cannot be used when it is in forced mode.

For example: to control the current, user can connect the ETR signal to the output of a comparator, and the operation for ETR should be as follow:

- Set `TIMx_SMCTRL.EXTPS=00` to disable the external trigger prescaler.
- Set `TIMx_SMCTRL.EXCEN=0` to disable the external clock mode 2.
- Set `TIMx_SMCTRL.EXTP` and `TIMx_SMCTRL.EXTF` to configure the external trigger polarity and external trigger filter according to the need.

For example: when ETRF input becomes high, the behavior of OCxREF signal for different value of OCxCEN. Timer is set to be in PWM mode in this case.

**Figure 9-25 Clearing The OCxREF of TIMx**





### 9.3.12 Complementary Outputs and Dead-time Insertion

Advanced-control timer can output two complementary signals with dead time in between, User should adjust dead-time depending on the devices connected to the outputs and their characteristics.

User can select the polarity of outputs by setting TIMx\_CCEN.CCxP and TIMx\_CCEN.CCxNP. And this selection is independently for each output.

User can control the complementary signals OCx and OCxN by setting the combination of several control bits, which are TIMx\_CCEN.CCxEN, TIMx\_CCEN.CCxNEN, TIMx\_BKDT.MOEN, TIMx\_CTRL2.OIx, TIMx\_CTRL2.OIxN, TIMx\_BKDT.OSSI, and TIMx\_BKDT.OSSR. When switching to the IDLE state, the dead-time will be activated.

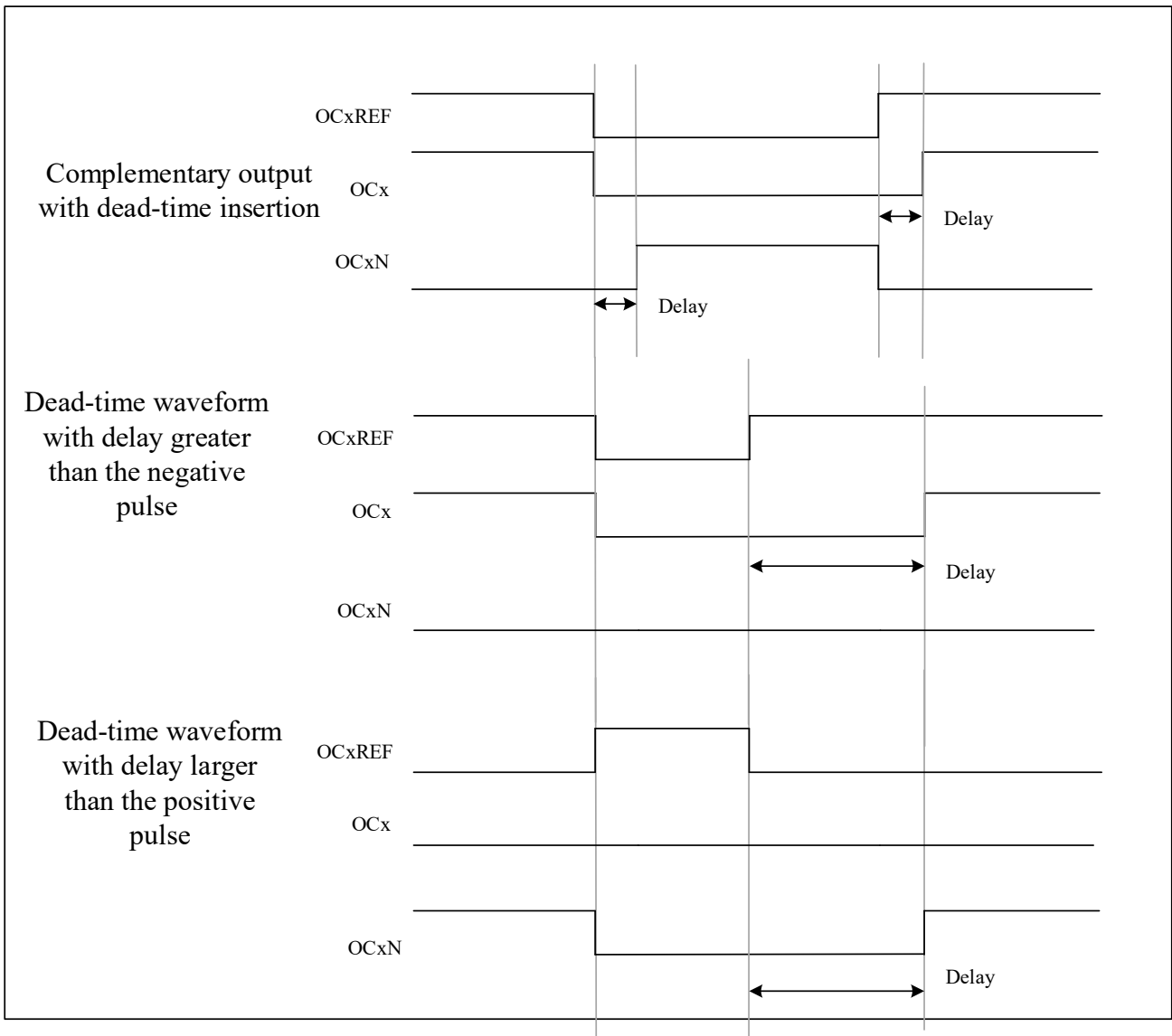
If user set TIMx\_CCEN.CCxEN and TIMx\_CCEN.CCxNEN at the same time, a dead-time will be insert. If there is a break circuit, the TIMx\_BKDT.MOEN should be set too. There are 10-bit dead-time generators for each channel.

Reference waveform OCxREF can generate 2 outputs OCx and OCxN. And if OCx and OCxN are active high level, the OCx output signal is the same as the reference signal and the OCxN output signal is the opposite of the reference signal. However, OCx will be delayed relative to the reference rising edge and the OCxN will be delayed relative to the reference falling edge. If the delay is greater than the width of the active OCx or OCxN, the corresponding pulse will not generated.

The relationships between the output signals of the dead-time generator and the reference signal OCxREF are as follow.

Assume that TIMx\_CCEN.CCxP=0, TIMx\_CCEN.CCxNP=0, TIMx\_BKDT.MOEN=1, TIMx\_CCEN.CCxEN=1, TIMx\_CCEN.CCxNEN=1.

Figure 9-26 Complementary Output with Dead-time Insertion



User can set TIMx\_BKDT.DTGN to programme the dead-time delay for each of the channels.

### 9.3.12.1 Redirecting OCxREF to OCx or OCxN

User can set TIMx\_CCEN.CCxEN and TIMx\_CCEN.CCxNEN to re-directed OCxREF to the OCx or to OCxN in output mode.

Here are two ways to use this function. When the complementary remains at its inactive level, user can use this function to send a specific waveform, such as PWM or static active level. User can also use this function to set both outputs in their inactive level or both outputs active and complementary with dead-time.

If user set TIMx\_CCEN.CCxEN=0 and TIMx\_CCEN.CCxNEN=1, it will not complemented, and OCxN will become active when OCxREF is high level. On the other hand, if user set TIMx\_CCEN.CCxEN=1 and TIMx\_CCEN.CCxNEN=1, OCx will become active when OCxREF is high level. On the contrary, OCxN will become active when OCxREF is low level.

### 9.3.13 Break Function

The output enable signals and inactive levels will be modified when setting the corresponding control bits when using the break function. However, at any time, the output of OCx and OCxN cannot at the active level at the same time, meaning it must satisfy  $(CCxP \wedge OIx) \wedge (CCxNP \wedge OIxN) = 0$ .

When multiple break signals are enabled, each break signal constitutes an OR logic. Here are some signal which can be the source of breaking.

- The break input pin
- A clock failure event, generated by the clock security system in the clock controller.
- A PVD failure event.
- Core Hardfault event.
- The output signal of the comparator (configured in the comparator module, high level break).
- By software through the TIMx\_EVTGEN.BGN.

The break circuit will be disable after reset. And the MOEN bit will be low. User can set TIMx\_BKDT.BKEN to enable the break function. The polarity of break input signal can be selected by setting TIMx\_BKDT.BKP. User can modify the TIMx\_BKDT.BKEN and TIMx\_BKDT.BKP at the same time. After user set the TIMx\_BKDT.BKEN and TIMx\_BKDT.BKP, there is 1 APB clock cycle delay before the configuration take effect. Therefore, user need to wait 1 APB clock cycle to read back the written bit value.

The falling edge of MOEN can be asynchronous, so a resynchronization circuit has been inserted between the actual signal and the synchronous control bit. This circuit will cause a delay between the asynchronous and the synchronous signal. When TIMx\_BKDT.MOEN is set to '0', user need to insert a delay before reading the value. Because an asynchronous signal was written but user read the synchronous signal.

The behaviors that after a break occurs are as follow:

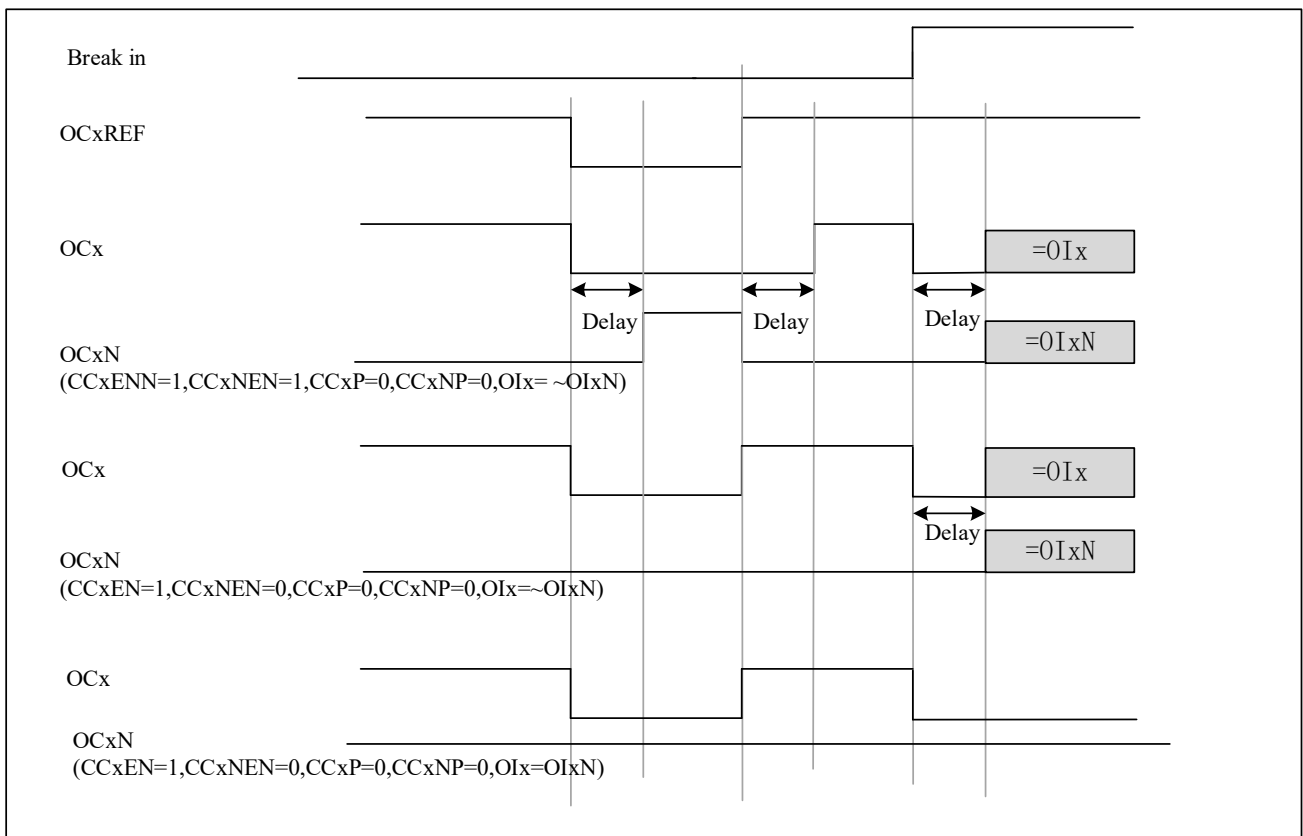
- TIMx\_BKDT.MOEN will be cleared asynchronously, and then the output will be put in inactive state, idle state or reset state. The state of output is selected by setting TIMx\_BKDT.OSSI. This will take effect even if the MCU oscillator is off.
- Once TIMx\_BKDT.MOEN=0, the output of each output channel will be driven with the level programmed in TIMx\_CTRL2.OIx. Timer will release the enable outputs(taken over by GPIO controller) if TIMx\_BKDT.OSSI=0, otherwise it will remains high.
- If user choose to use complementary outputs, the behaviors of TIM are as follow
  - Depends on the polarity, the outputs will be set in reset state first. It is an asynchronous option so it still operates even if there is no clock provided to the timer.
  - The dead-time generator will be reactivated if the timer clock is still provided, and drive the outputs according to the value of TIMx\_CTRL2.OIx and TIMx\_CTRL2.OIxN after the dead-time when  $(CCxP \wedge OIx) \wedge (CCxNP \wedge OIxN) = 0$ , meaning the OCx and OCxN still cannot be driven to active level at the same time. Note that the dead-time will be longer than usual because of the resynchronization on MOEN (almost 2 cycles of ck\_tim).

- Timer will release the output control if TIMx\_BKDT.OSSI=0. Otherwise, if the enable output was high, it will remain high. If it was low, it will become high when TIMx\_CCEN.CCxEN or TIMx\_CCEN.CCxNEN is high.
- If TIMx\_DINTEN.BIEN=1, when TIMx\_STS.BITF=1, an interrupt will be generated.
- If user set TIMx\_BKDT.AOEN, the TIMx\_BKDT.MOEN will be set automatically when the next UEV happened. User can use this to regulate. If user did not set TIMx\_BKDT.AOEN, the TIMx\_BKDT.MOEN will remain low until been set 1 again. At this situation, user can use this for security. User can connect the break input to thermal sensors, alarm for power drivers, or other security components.
- When the break input is active, TIMx\_BKDT.MOEN cannot be set automatically or by software at the same time, and the TIMx\_STS.BITF cannot be cleared. Because the break inputs are active on level.

To insure the security of application, the break circuit has the write protection function, and there is break input and output management too. It allow user to freeze some parameters, such as dead-time duration, OCx/OCxN polarities and state when disabled, OCxMD configurations, break enable and polarity. User can choose one of the 3 levels of protection to use by setting TIMx\_BKDT.LCKCFG. However, the TIMx\_BKDT.LCKCFG can only be written once after an MCU reset.

An example for output behavior in response to a break is as follow

**Figure 9-27 Output Behavior in Response to A Break**



### 9.3.14 Debug Mode

When the microcontroller is in debug mode (the Cortex<sup>®</sup>-M0 core halted), depending on the DBG\_CTRL.TIMx\_STOP configuration in the PWR module, the TIMx counter can either continue to operate normally or stop. For more details, refer

to 3.3.2.

### 9.3.15 TIMx and External Trigger Synchronization

TIMx can be synchronized by a trigger in slave modes (reset, trigger and gated).

#### 9.3.15.1 Slave mode: reset mode

In reset mode, the trigger event can reset the counter and the prescaler, updates the preload registers TIMx\_AR, TIMx\_CCDATx, and generates the update event UEV (TIMx\_CTRL1.UPRS=0).

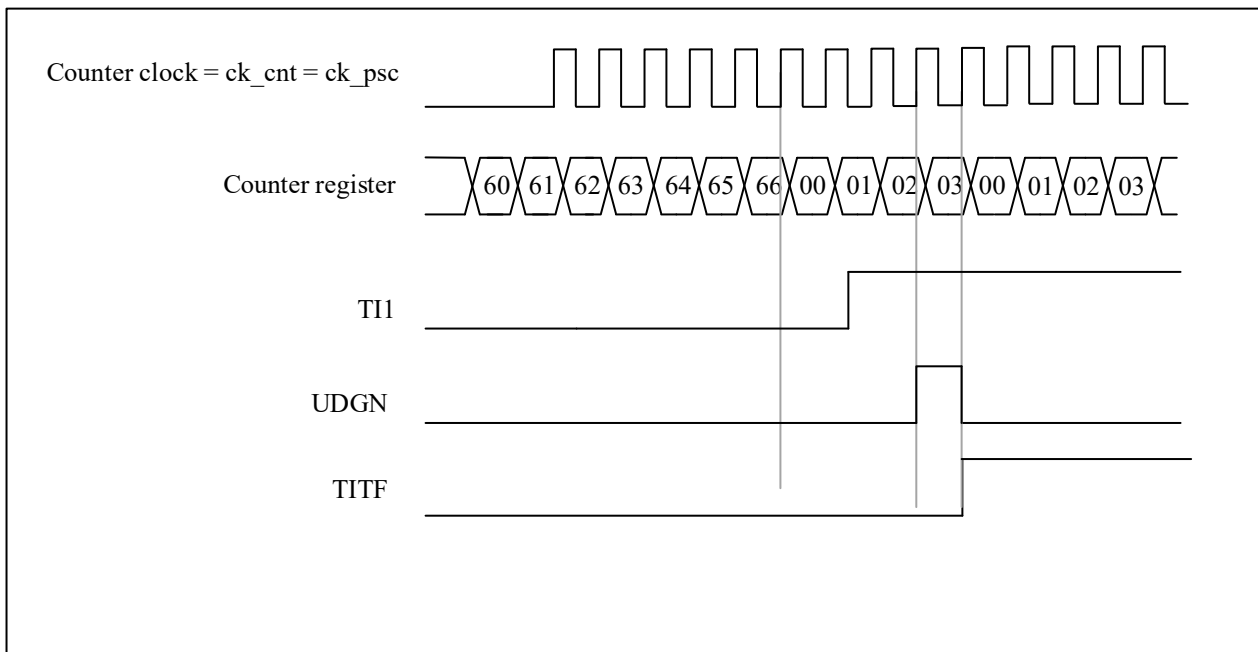
The following is an example of a reset mode:

1. Channel 1 is configured as input to detect the rising edge of TI1 (TIMx\_CCMOD1.CC1SEL=01, TIMx\_CCEN.CC1P=0);
2. The slave mode is selected as reset mode (TIMx\_SMCTRL.SMSEL=100), and the trigger input is selected as TI1 (TIMx\_SMCTRL.TSEL=101);
3. Start counter(TIMx\_CTRL1.CNTEN = 1).

After starting the timer, when TI1 detects a rising edge, the counter resets and restarts counting, and the trigger flag is set (TIMx\_STS.TITF=1);

The delay between the rising edge of TI1 and the actual reset of the counter is caused by the resynchronization circuit at the TI1 input.

**Figure 9-28 Control Circuit in Reset Mode**



#### 9.3.15.2 Slave mode: trigger mode

In trigger mode, the trigger event (rising edge/falling edge) of the input port can trigger the counter to start counting.

The following is an example of a trigger pattern:

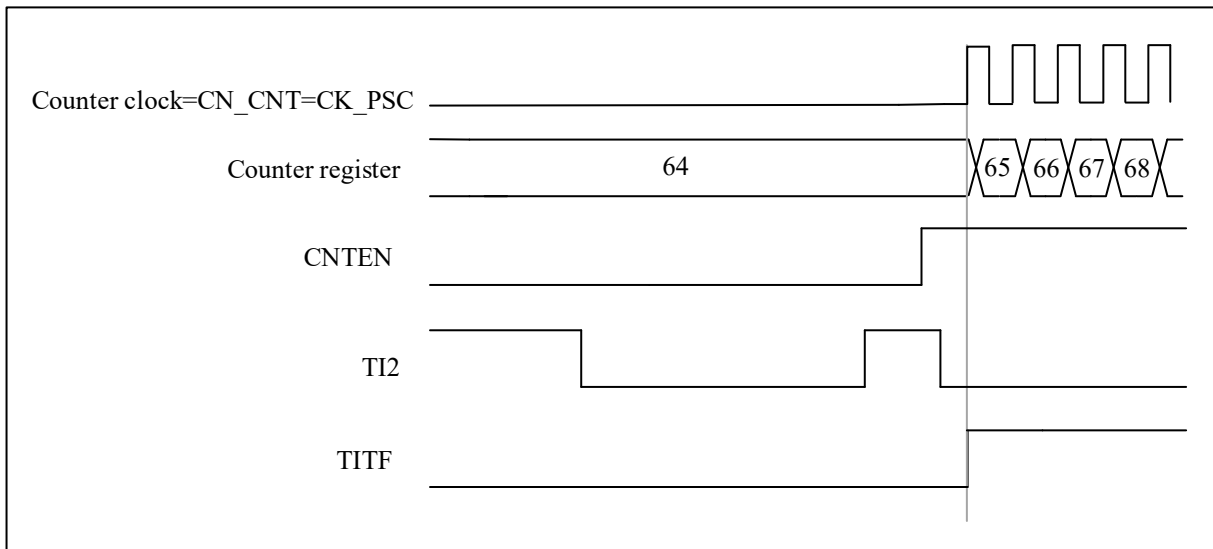
1. Channel 2 is configured as input to detect the rising edge of TI2 (TIMx\_CCMOD1.CC2SEL=01, TIMx\_CCEN.CC2P=0);

2. Select from mode to trigger mode (TIMx\_SMCTRL.SMSEL=110), select TI2 for trigger input (TIMx\_SMCTRL.TSEL=110);

When a rising edge is detected on TI2, the counter starts counting, and the trigger flag is set (TIMx\_STS.TITF=1);

The delay between the rising edge of TI2 and the actual start of the counter is caused by the resynchronization circuit at the TI2 input.

Figure 9-29 Control Circuit in Trigger Mode



**9.3.15.3 Slave mode: gated mode**

In gate control mode, the level polarity of the input port can control whether the counter counts.

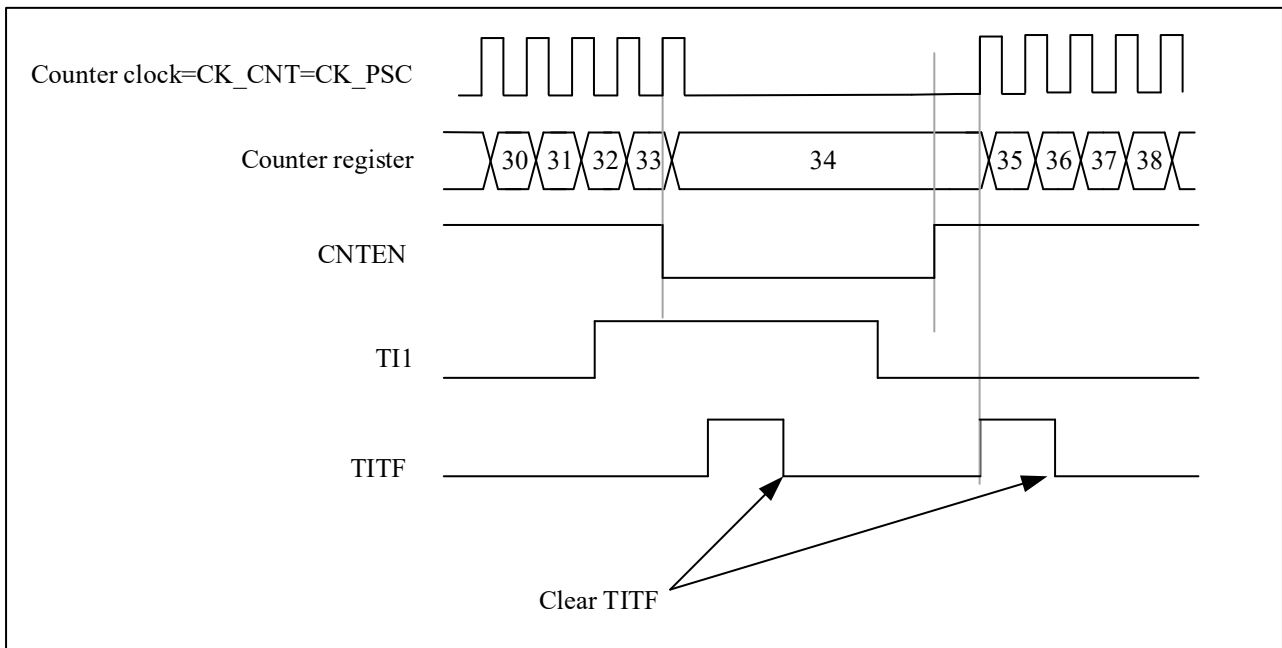
The following is an example of a gated pattern:

1. Channel 1 is configured as input detection active low on TI1 (TIMx\_CCMOD1.CC1SEL=01, TIMx\_CCEN.CC1P=1);
2. Select the slave mode as the gated mode (TIMx\_SMCTRL.SMSEL=101), and select TI1 as the trigger input (TIMx\_SMCTRL.TSEL=101);
3. Start counter(TIMx\_CTRL1.CNTEN=1).

When TI1 detects that the level changes from low to high, the counter stops counting, and when TI1 detects that the level changes from high to low, the counter starts counting, and the trigger flag will be set (TIMx\_STS.TITF=1) when it starts or stops counting ;

The delay between the rising edge of TI1 and the actual stop of the counter is caused by the resynchronization circuit at the TI1 input.

Figure 9-30 Control Circuit in Gated Mode



**9.3.15.4 Slave mode: trigger mode + external clock mode 2**

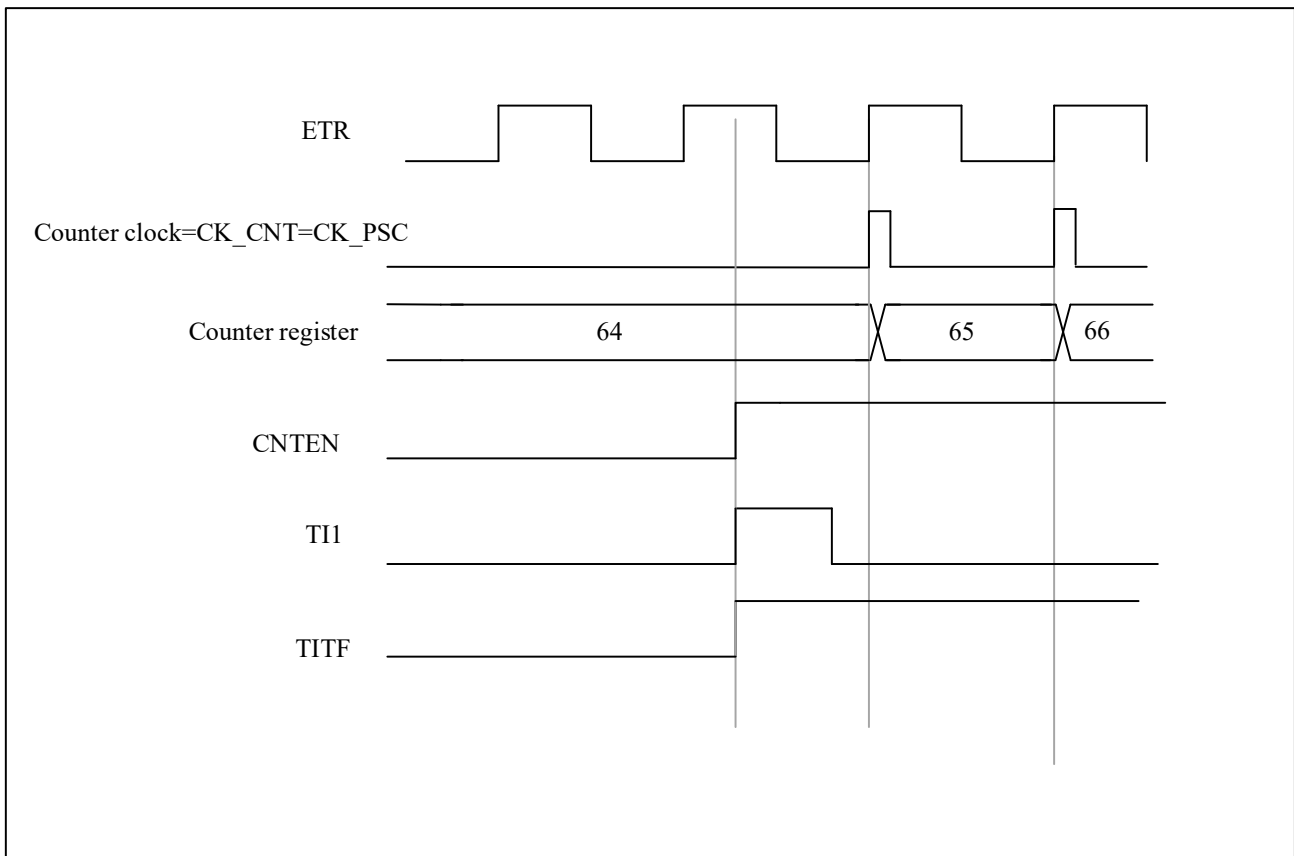
In reset mode, trigger mode and gate control mode, the counter clock can be selected as external clock mode 2, and the ETR signal is used as the external clock source input. At this time, the trigger selection needs to select non-ETRF (TIMx\_SMCTRL.TSEL=111).

Here is an example:

1. Channel 1 is configured as input to detect the rising edge of TI1 (TIMx\_CCMOD1.CC1SEL=01, TIMx\_CCEN.CC1P=0);
2. Enable external clock mode 2 (TIMx\_SMCTRL.EXCEN=1), select rising edge for external trigger polarity (TIMx\_SMCTRL.EXTP=0), select slave mode as trigger mode (TIMx\_SMCTRL.SMSEL=110), select TI1 for trigger input (TIMx\_SMCTRL.TSEL=101);

When TI1 detects a rising edge, the counter starts counting on the rising edge of ETR, and the trigger flag is set (TIMx\_STS.TITF=1);

Figure 9-31 Control Circuit in Trigger Mode + External Clock Mode2



### 9.3.16 Timer Synchronization

All TIM are internally connected for timer synchronization or chaining. For more details, refer to 10.3.14.

### 9.3.17 Generating Six-step PWM Output

In order to modify the configuration of all channels at the same time, the configuration of the next step can be set in advance (the preloaded bits are OCxMD, CCxEN and CCxNEN). When a COM commutation event occurs, the OCxMD, CCxEN, and CCxNEN preload bits are transferred to the shadow register bits.

Methods to generate a COM commutation event:

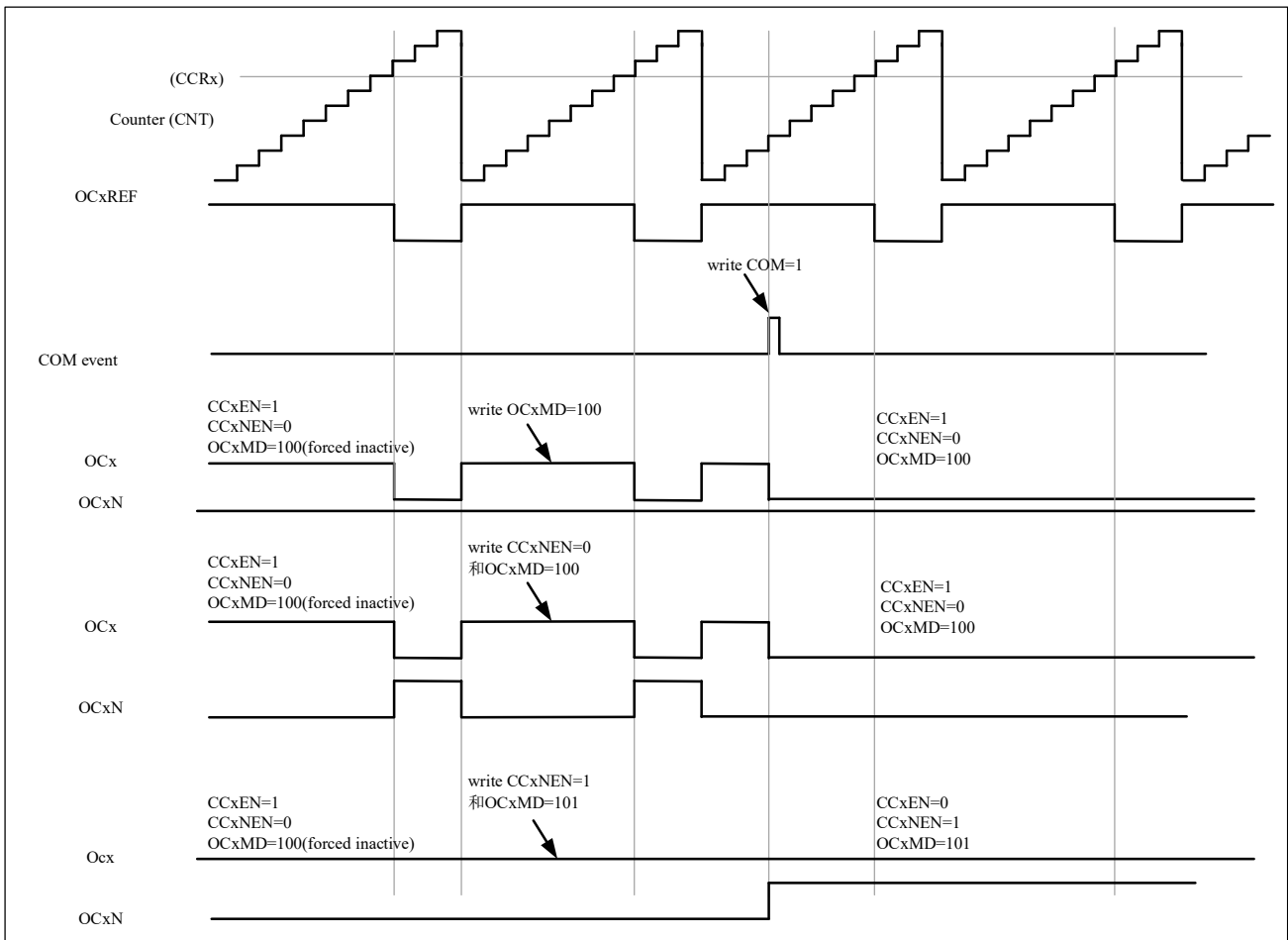
1. Set TIMx\_EVTGEN.CCUDGN by software;
2. Generated by hardware on the rising edge of TRGI;

When a COM commutation event occurs, the TIMx\_STS.COMITF flag will be set, enabling interrupts (TIMx\_DINTEN.COMIEN) will generate interrupts, and enabling DMA requests (TIMx\_DINTEN.COMDEN) will generate DMA requests.

The following figure shows the output timing diagram of OCx and OCxN when a COM commutation event occurs in three different configurations:



Figure 9-32 6-step PWM Generation, COM Example (OSSR=1)



### 9.3.18 Encoder Interface Mode

The encoder uses two inputs TI1 and TI2 as the interface and the counter counts on every edge change on TI1FP1 or TI2FP2. The counting direction is automatically controlled by hardware TIMx\_CTRL1.DIR. There are three types of encoder counting modes:

1. The counter only counts on the edge of TI1, TIMx\_SMCTRL.SMSEL = '001';
2. The counter only counts on the edge of TI2, TIMx\_SMCTRL.SMSEL = '010';
3. The counter counts on the edges of TI1 and TI2 at the same time, TIMx\_SMCTRL.SMSEL = '011';

The encoder interface is equivalent to using an external clock with direction selection, and the counter only counts continuously between 0 and the auto-reload value (TIMx\_AR.AR [15:0]). Therefore, it is necessary to configure the auto-reload register TIMx\_AR in advance.

*Note: Encoder mode and external clock mode 2 are not compatible and must not be selected together.*

The relationship between the counting direction and the encoder signals is shown in **Table 9-1 Counting Direction Versus Encoder Signals**:

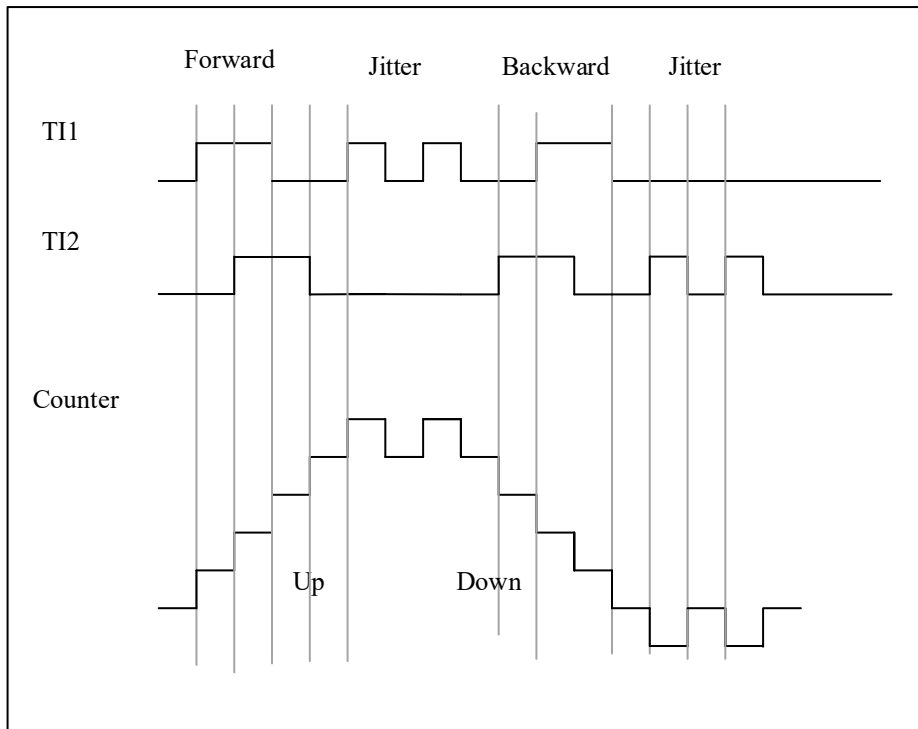
**Table 9-1 Counting Direction Versus Encoder Signals**

| Active Edge             | Level On Opposite Signals<br>(TI1FP1 For TI2,<br>TI2FP2 For TI1) | TI1FP1 Signal |               | TI2FP2 Signal |               |
|-------------------------|--|---------------|---------------|---------------|---------------|
|                         |  | Rising        | Falling       | Rising        | Falling       |
| Counting only at TI1    | High   | Counting down | Counting up   | Don't count   | Don't count   |
|                         | Low  | Counting up   | Counting down | Don't count   | Don't count   |
| Counting only at TI2    | High   | Don't count   | Don't count   | Counting up   | Counting down |
|                         | Low  | Don't count   | Don't count   | Counting down | Counting up   |
| Counting on TI1 and TI2 | High   | Counting down | Counting up   | Counting up   | Counting down |
|                         | Low  | Counting up   | Counting down | Counting down | Counting up   |

Here is an example of an encoder with dual edge selected for triggering to suppress input jitter:

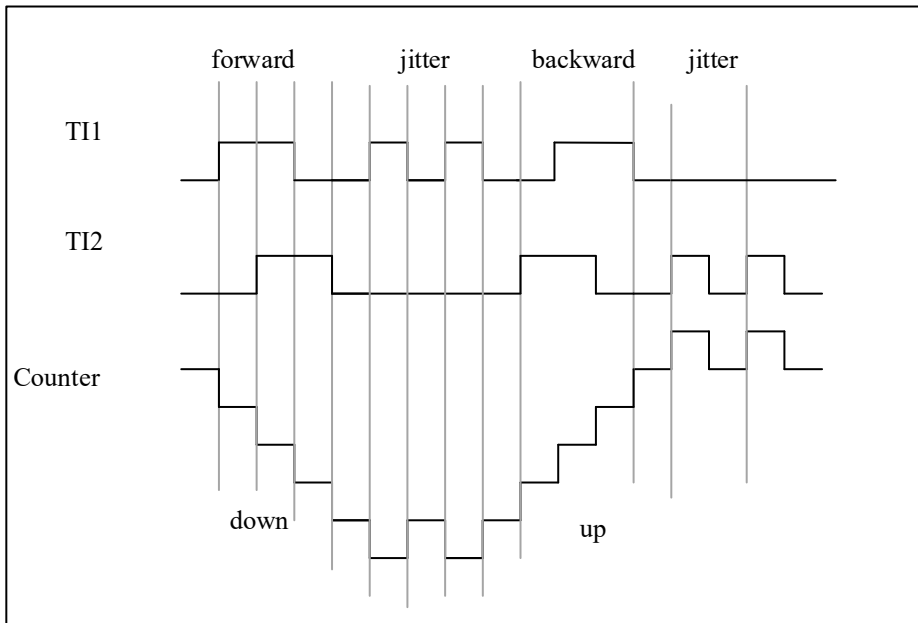
1. IC1FP1 is mapped to TI1 (TIMx\_CCMOD1.CC1SEL= '01'), IC1FP1 is not inverted (TIMx\_CCEN.CC1P= '0');
2. IC1FP2 is mapped to TI2 (TIMx\_CCMOD2.CC2SEL= '01'), IC2FP2 is not inverted (TIMx\_CCEN.CC2P= '0');
3. The input is valid on both rising and falling edges (TIMx\_SMCTRL.SMSEL = '011');
4. Enable counter TIMx\_CTRL1.CNTEN= '1';

**Figure 9-33 Example of Counter Operation in Encoder Interface Mode**



The following figure shows the example of counter behavior when IC1FP1 polarity is inverted (CC1P= '1', other configurations are the same as above)

**Figure 9-34 Encoder Interface Mode Example with IC1FP1 Polarity Inverted**



### 9.3.19 Interfacing with Hall Sensor

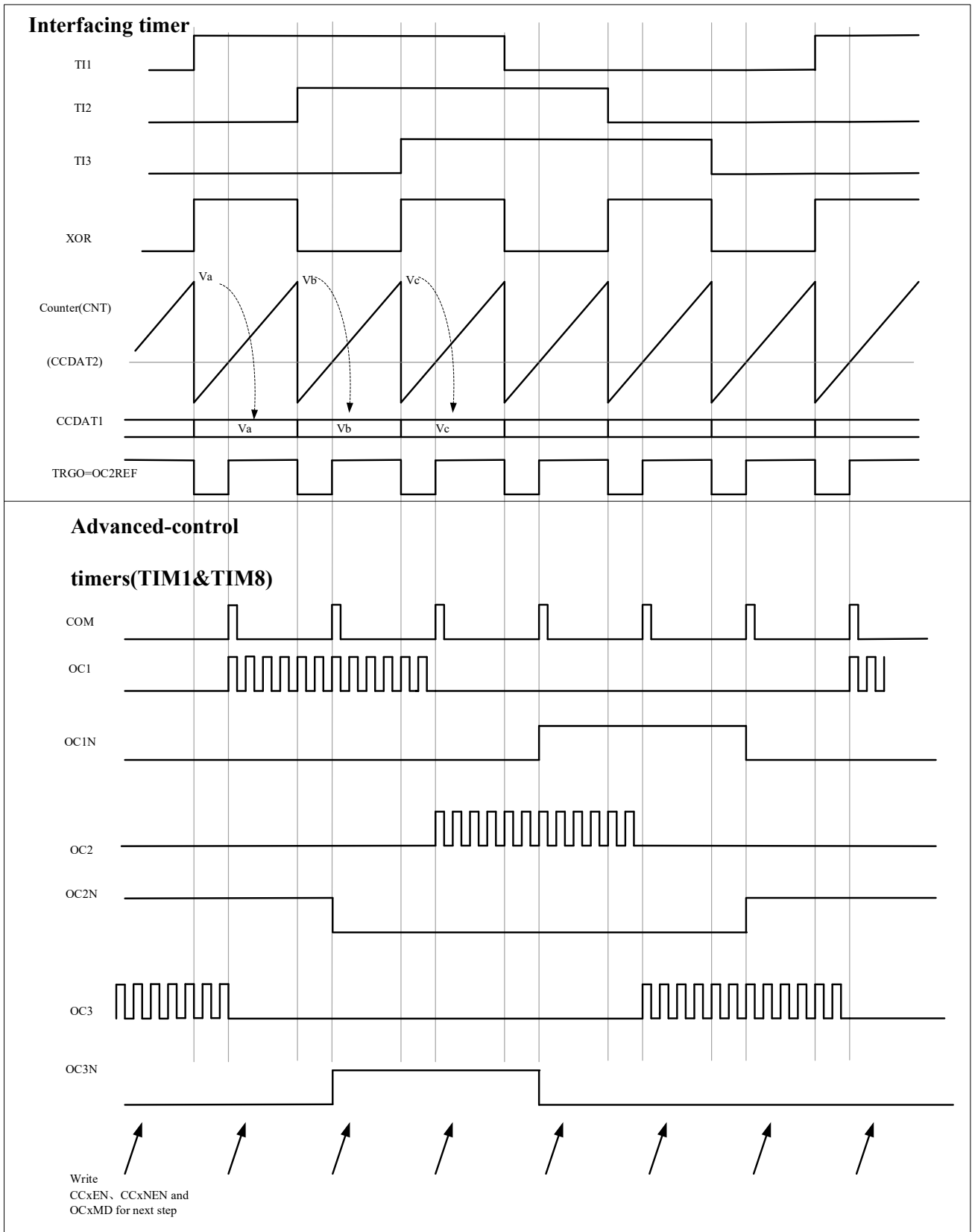
Connect the Hall sensor to the three input pins (CC1, CC2 and CC3) of the timer, and then select the XOR function to route the inputs of TIMx\_CH1, TIMx\_CH2 and TIMx\_CH3 through the XOR gate as the output of TI1 to channel 1 for capturing signal.

The timer needs to be configured as the reset mode in slave mode (TIMx\_SMCTRL.SMSEL= '100'); select the edge-trigger TI1 as TI1F\_ED (TIMx\_SMCTRL.TSEL= '100'), any change in the Hall 3 inputs will trigger the counter to recount, so it is used as a time reference; the capture/compare channel 1 is configured to capture the TRC signal in capture mode (TIMx\_CCMOD1.CC1SEL= '11'), which is used to calculate the two input time intervals, thereby reflecting the motor speed.

Select timer channel 2 to generate a pulse to the advanced timer, trigger the COM event of the advanced timer, and update the control bits for the PWM output. The trigger selection of the advanced timer needs to select the corresponding internal trigger signal (TIMx\_SMCTRL.TSEL="ITRx"), the capture/compare preload control bit needs to be configured to support preload (TIMx\_CTRL2.CCPCTL=1) and support the rising edge of TRGI Trigger an update (TIMx\_CTRL2.CCUSEL=1).

This example is shown in the following figure.

Figure 9-35 Example of Hall Sensor Interface



## 9.4 TIMx Register Description(x=1, 8)

For abbreviations used in registers, refer to section 1.1

These peripheral registers can be operated as half word (16-bits) or one word (32-bits).

### 9.4.1 Register Overview

**Table 9-2 Register Overview**

| Offset | Register                           | 31       | 30 | 29 | 28 | 27 | 26 | 25 | 24 | 23 | 22 | 21 | 20 | 19 | 18 | 17        | 16         | 15       | 14          | 13          | 12          | 11        | 10       | 9          | 8           | 7           | 6          | 5          | 4           | 3      | 2      | 1      | 0        |        |       |   |   |   |   |   |   |   |   |   |   |   |   |
|--------|------------------------------------|----------|----|----|----|----|----|----|----|----|----|----|----|----|----|-----------|------------|----------|-------------|-------------|-------------|-----------|----------|------------|-------------|-------------|------------|------------|-------------|--------|--------|--------|----------|--------|-------|---|---|---|---|---|---|---|---|---|---|---|---|
| 000h   | TIMx_CTRL1                         | Reserved |    |    |    |    |    |    |    |    |    |    |    |    |    | PBKPEN    | LBKPEN     | CLRSEL   | Reserved    | Reserved    | Reserved    | C1SEL     | IOMBKPEN | CLKD[1:0]  |             | ARPEN       | CAMEL[1:0] |            |             | DIR    | ONEPM  | UPRS   | UPDIS    | CNTEN  |       |   |   |   |   |   |   |   |   |   |   |   |   |
|        | Reset Value                        | 0        |    |    |    |    |    |    |    |    |    |    |    |    |    | 0         | 0          | 0        | 0           | 0           | 0           | 0         | 0        | 0          | 0           | 0           | 0          | 0          | 0           | 0      | 0      | 0      | 0        | 0      | 0     | 0 | 0 | 0 | 0 | 0 | 0 | 0 | 0 | 0 | 0 | 0 |   |
| 004h   | TIMx_CTRL2                         | Reserved |    |    |    |    |    |    |    |    |    |    |    |    |    | O16       | Reserved   | O15      | Reserved    | O14         | O13N        | O13       | O12N     | O12        | O11N        | O11         | TI1SEL     | MMSEL[2:0] |             |        | CCDSEL | CCUSEL | Reserved | CCPCTL |       |   |   |   |   |   |   |   |   |   |   |   |   |
|        | Reset Value                        | 0        |    |    |    |    |    |    |    |    |    |    |    |    |    | 0         | 0          | 0        | 0           | 0           | 0           | 0         | 0        | 0          | 0           | 0           | 0          | 0          | 0           | 0      | 0      | 0      | 0        | 0      | 0     | 0 | 0 | 0 | 0 | 0 | 0 | 0 | 0 | 0 | 0 | 0 |   |
| 008h   | TIMx_SMCTRL                        | Reserved |    |    |    |    |    |    |    |    |    |    |    |    |    | EXTP      |            | EXCEN    | EXTPS[1:0]  |             | EXTF[3:0]   |           |          | MSMD       | TSEL[2:0]   |             |            | Reserved   | SMSEL[2:0]  |        |        |        |          |        |       |   |   |   |   |   |   |   |   |   |   |   |   |
|        | Reset Value                        | 0        |    |    |    |    |    |    |    |    |    |    |    |    |    | 0         | 0          | 0        | 0           | 0           | 0           | 0         | 0        | 0          | 0           | 0           | 0          | 0          | 0           | 0      | 0      | 0      | 0        | 0      | 0     | 0 | 0 | 0 | 0 | 0 | 0 | 0 | 0 | 0 | 0 | 0 | 0 |
| 00Ch   | TIMx_DINTEN                        | Reserved |    |    |    |    |    |    |    |    |    |    |    |    |    | TDEN      | COMDEN     | CC4DEN   | CC3DEN      | CC2DEN      | CC1DEN      | UDEN      | BIEN     | TIEN       | COMIEN      | CC4IEN      | CC3IEN     | CC2IEN     | CC1IEN      | UIEN   |        |        |          |        |       |   |   |   |   |   |   |   |   |   |   |   |   |
|        | Reset Value                        | 0        |    |    |    |    |    |    |    |    |    |    |    |    |    | 0         | 0          | 0        | 0           | 0           | 0           | 0         | 0        | 0          | 0           | 0           | 0          | 0          | 0           | 0      | 0      | 0      | 0        | 0      | 0     | 0 | 0 | 0 | 0 | 0 | 0 | 0 | 0 | 0 | 0 | 0 |   |
| 010h   | TIMx_STS                           | Reserved |    |    |    |    |    |    |    |    |    |    |    |    |    | CC6ITF    | CC3ITF     | Reserved | CC4OCF      | CC3OCF      | CC2OCF      | CC1OCF    | Reserved | BITF       | TITF        | COMITF      | CC4ITF     | CC3ITF     | CC2ITF      | CC1ITF | UDITF  |        |          |        |       |   |   |   |   |   |   |   |   |   |   |   |   |
|        | Reset Value                        | 0        |    |    |    |    |    |    |    |    |    |    |    |    |    | 0         | 0          | 0        | 0           | 0           | 0           | 0         | 0        | 0          | 0           | 0           | 0          | 0          | 0           | 0      | 0      | 0      | 0        | 0      | 0     | 0 | 0 | 0 | 0 | 0 | 0 | 0 | 0 | 0 | 0 | 0 |   |
| 014h   | TIMx_EVTGEN                        | Reserved |    |    |    |    |    |    |    |    |    |    |    |    |    | BGN       | TGN        | CCUDGN   | CC4GN       | CC3GN       | CC2GN       | CC1GN     | UDGN     |            |             |             |            |            |             |        |        |        |          |        |       |   |   |   |   |   |   |   |   |   |   |   |   |
|        | Reset Value                        | 0        |    |    |    |    |    |    |    |    |    |    |    |    |    | 0         | 0          | 0        | 0           | 0           | 0           | 0         | 0        | 0          | 0           | 0           | 0          | 0          | 0           | 0      | 0      | 0      | 0        | 0      | 0     | 0 | 0 | 0 | 0 | 0 | 0 | 0 | 0 | 0 | 0 | 0 | 0 |
| 018h   | TIMx_CCMOD1<br>Output compare mode | Reserved |    |    |    |    |    |    |    |    |    |    |    |    |    | OC2CEN    | OC2MD[2:0] |          | OC2PEN      | OC2FEN      | OC2SEL[1:0] |           | OC1CEN   | OC1MD[2:0] |             |             | OC1PEN     | OC1FEN     | OC1SEL[1:0] |        |        |        |          |        |       |   |   |   |   |   |   |   |   |   |   |   |   |
|        | Reset Value                        | 0        |    |    |    |    |    |    |    |    |    |    |    |    |    | 0         | 0          | 0        | 0           | 0           | 0           | 0         | 0        | 0          | 0           | 0           | 0          | 0          | 0           | 0      | 0      | 0      | 0        | 0      | 0     | 0 | 0 | 0 | 0 | 0 | 0 | 0 | 0 | 0 | 0 | 0 | 0 |
| 018h   | TIMx_CCMOD1<br>Input capture mode  | Reserved |    |    |    |    |    |    |    |    |    |    |    |    |    | IC2F[3:0] |            |          | IC2PSC[1:0] | CC2SEL[1:0] |             | IC1F[3:0] |          |            | IC1PSC[1:0] | CC1SEL[1:0] |            |            |             |        |        |        |          |        |       |   |   |   |   |   |   |   |   |   |   |   |   |
|        | Reset Value                        | 0        |    |    |    |    |    |    |    |    |    |    |    |    |    | 0         | 0          | 0        | 0           | 0           | 0           | 0         | 0        | 0          | 0           | 0           | 0          | 0          | 0           | 0      | 0      | 0      | 0        | 0      | 0     | 0 | 0 | 0 | 0 | 0 | 0 | 0 | 0 | 0 | 0 | 0 | 0 |
| 01Ch   | TIMx_CCMOD2<br>Output compare mode | Reserved |    |    |    |    |    |    |    |    |    |    |    |    |    | OC4CEN    | OC4MD[2:0] |          | OC4PEN      | OC4FEN      | OC4SEL[1:0] |           | OC3CEN   | OC3MD[2:0] |             |             | OC3PEN     | OC3FEN     | OC3SEL[1:0] |        |        |        |          |        |       |   |   |   |   |   |   |   |   |   |   |   |   |
|        | Reset Value                        | 0        |    |    |    |    |    |    |    |    |    |    |    |    |    | 0         | 0          | 0        | 0           | 0           | 0           | 0         | 0        | 0          | 0           | 0           | 0          | 0          | 0           | 0      | 0      | 0      | 0        | 0      | 0     | 0 | 0 | 0 | 0 | 0 | 0 | 0 | 0 | 0 | 0 | 0 | 0 |
| 01Ch   | TIMx_CCMOD2<br>Input capture mode  | Reserved |    |    |    |    |    |    |    |    |    |    |    |    |    | IC4F[3:0] |            |          | IC4PSC[1:0] | CC4SEL[1:0] |             | IC3F[3:0] |          |            | IC3PSC[1:0] | CC3SEL[1:0] |            |            |             |        |        |        |          |        |       |   |   |   |   |   |   |   |   |   |   |   |   |
|        | Reset Value                        | 0        |    |    |    |    |    |    |    |    |    |    |    |    |    | 0         | 0          | 0        | 0           | 0           | 0           | 0         | 0        | 0          | 0           | 0           | 0          | 0          | 0           | 0      | 0      | 0      | 0        | 0      | 0     | 0 | 0 | 0 | 0 | 0 | 0 | 0 | 0 | 0 | 0 | 0 | 0 |
| 020h   | TIMx_CCEN                          | Reserved |    |    |    |    |    |    |    |    |    |    |    |    |    | CC6P      | CC6EN      | Reserved | CC5P        | CC5EN       | Reserved    | CC4P      | CC4EN    | CC3NP      | CC3NEN      | CC3P        | CC3EN      | CC2NP      | CC2NEN      | CC2P   | CC2EN  | CC1NP  | CC1NEN   | CC1P   | CC1EN |   |   |   |   |   |   |   |   |   |   |   |   |

| Offset | Register    | 31       | 30 | 29 | 28 | 27 | 26 | 25 | 24 | 23 | 22 | 21 | 20 | 19           | 18         | 17  | 16          | 15       | 14       | 13          | 12          | 11 | 10     | 9      | 8        | 7 | 6 | 5 | 4 | 3 | 2 | 1 | 0 |   |   |   |   |   |   |   |   |   |   |   |   |   |   |
|--------|-------------|----------|----|----|----|----|----|----|----|----|----|----|----|--------------|------------|-----|-------------|----------|----------|-------------|-------------|----|--------|--------|----------|---|---|---|---|---|---|---|---|---|---|---|---|---|---|---|---|---|---|---|---|---|---|
|        | Reset Value |          |    |    |    |    |    |    |    |    |    |    |    | 0            | 0          |     |             |          |          | 0           | 0           |    |        |        |          |   |   |   |   |   |   |   |   |   |   |   |   |   |   |   |   |   |   |   |   |   |   |
| 024h   | TIMx_CNT    | Reserved |    |    |    |    |    |    |    |    |    |    |    | CNT[15:0]    |            |     |             |          |          |             |             |    |        |        |          |   |   |   |   |   |   |   |   |   |   |   |   |   |   |   |   |   |   |   |   |   |   |
|        | Reset Value |          |    |    |    |    |    |    |    |    |    |    |    | 0            | 0          | 0   | 0           | 0        | 0        | 0           | 0           | 0  | 0      | 0      | 0        | 0 | 0 | 0 | 0 | 0 | 0 | 0 | 0 | 0 | 0 | 0 | 0 | 0 | 0 | 0 | 0 | 0 | 0 | 0 |   |   |   |
| 028h   | TIMx_PSC    | Reserved |    |    |    |    |    |    |    |    |    |    |    | PSC[15:0]    |            |     |             |          |          |             |             |    |        |        |          |   |   |   |   |   |   |   |   |   |   |   |   |   |   |   |   |   |   |   |   |   |   |
|        | Reset Value |          |    |    |    |    |    |    |    |    |    |    |    | 0            | 0          | 0   | 0           | 0        | 0        | 0           | 0           | 0  | 0      | 0      | 0        | 0 | 0 | 0 | 0 | 0 | 0 | 0 | 0 | 0 | 0 | 0 | 0 | 0 | 0 | 0 | 0 | 0 | 0 | 0 |   |   |   |
| 02Ch   | TIMx_AR     | Reserved |    |    |    |    |    |    |    |    |    |    |    | AR[15:0]     |            |     |             |          |          |             |             |    |        |        |          |   |   |   |   |   |   |   |   |   |   |   |   |   |   |   |   |   |   |   |   |   |   |
|        | Reset Value |          |    |    |    |    |    |    |    |    |    |    |    | 1            | 1          | 1   | 1           | 1        | 1        | 1           | 1           | 1  | 1      | 1      | 1        | 1 | 1 | 1 | 1 | 1 | 1 | 1 | 1 | 1 | 1 | 1 | 1 | 1 | 1 | 1 | 1 | 1 | 1 | 1 |   |   |   |
| 030h   | TIMx_REPCNT | Reserved |    |    |    |    |    |    |    |    |    |    |    |              |            |     | REPCNT[7:0] |          |          |             |             |    |        |        |          |   |   |   |   |   |   |   |   |   |   |   |   |   |   |   |   |   |   |   |   |   |   |
|        | Reset Value |          |    |    |    |    |    |    |    |    |    |    |    |              |            |     | 0           | 0        | 0        | 0           | 0           | 0  | 0      | 0      | 0        | 0 | 0 | 0 | 0 | 0 | 0 | 0 | 0 | 0 | 0 | 0 | 0 | 0 | 0 | 0 | 0 | 0 | 0 | 0 | 0 | 0 | 0 |
| 034h   | TIMx_CCDAT1 | Reserved |    |    |    |    |    |    |    |    |    |    |    | CCDAT1[15:0] |            |     |             |          |          |             |             |    |        |        |          |   |   |   |   |   |   |   |   |   |   |   |   |   |   |   |   |   |   |   |   |   |   |
|        | Reset Value |          |    |    |    |    |    |    |    |    |    |    |    | 0            | 0          | 0   | 0           | 0        | 0        | 0           | 0           | 0  | 0      | 0      | 0        | 0 | 0 | 0 | 0 | 0 | 0 | 0 | 0 | 0 | 0 | 0 | 0 | 0 | 0 | 0 | 0 | 0 | 0 | 0 | 0 |   |   |
| 038h   | TIMx_CCDAT2 | Reserved |    |    |    |    |    |    |    |    |    |    |    | CCDAT2[15:0] |            |     |             |          |          |             |             |    |        |        |          |   |   |   |   |   |   |   |   |   |   |   |   |   |   |   |   |   |   |   |   |   |   |
|        | Reset Value |          |    |    |    |    |    |    |    |    |    |    |    | 0            | 0          | 0   | 0           | 0        | 0        | 0           | 0           | 0  | 0      | 0      | 0        | 0 | 0 | 0 | 0 | 0 | 0 | 0 | 0 | 0 | 0 | 0 | 0 | 0 | 0 | 0 | 0 | 0 | 0 | 0 | 0 |   |   |
| 03Ch   | TIMx_CCDAT3 | Reserved |    |    |    |    |    |    |    |    |    |    |    | CCDAT3[15:0] |            |     |             |          |          |             |             |    |        |        |          |   |   |   |   |   |   |   |   |   |   |   |   |   |   |   |   |   |   |   |   |   |   |
|        | Reset Value |          |    |    |    |    |    |    |    |    |    |    |    | 0            | 0          | 0   | 0           | 0        | 0        | 0           | 0           | 0  | 0      | 0      | 0        | 0 | 0 | 0 | 0 | 0 | 0 | 0 | 0 | 0 | 0 | 0 | 0 | 0 | 0 | 0 | 0 | 0 | 0 | 0 | 0 |   |   |
| 040h   | TIMx_CCDAT4 | Reserved |    |    |    |    |    |    |    |    |    |    |    | CCDAT4[15:0] |            |     |             |          |          |             |             |    |        |        |          |   |   |   |   |   |   |   |   |   |   |   |   |   |   |   |   |   |   |   |   |   |   |
|        | Reset Value |          |    |    |    |    |    |    |    |    |    |    |    | 0            | 0          | 0   | 0           | 0        | 0        | 0           | 0           | 0  | 0      | 0      | 0        | 0 | 0 | 0 | 0 | 0 | 0 | 0 | 0 | 0 | 0 | 0 | 0 | 0 | 0 | 0 | 0 | 0 | 0 | 0 | 0 |   |   |
| 044h   | TIMx_BKDT   | Reserved |    |    |    |    |    |    |    |    |    |    |    | MOEN         | AOEN       | BKP | BKEN        | OSSR     | OSSI     | LCKCFG[1:0] | DTGN[7:0]   |    |        |        |          |   |   |   |   |   |   |   |   |   |   |   |   |   |   |   |   |   |   |   |   |   |   |
|        | Reset Value |          |    |    |    |    |    |    |    |    |    |    |    | 0            | 0          | 0   | 0           | 0        | 0        | 0           | 0           | 0  | 0      | 0      | 0        | 0 | 0 | 0 | 0 | 0 | 0 | 0 | 0 | 0 | 0 | 0 | 0 | 0 | 0 | 0 | 0 | 0 | 0 | 0 | 0 |   |   |
| 048h   | TIMx_DCTRL  | Reserved |    |    |    |    |    |    |    |    |    |    |    | DBLEN[4:0]   |            |     |             | Reserved |          |             | DBADDR[4:0] |    |        |        |          |   |   |   |   |   |   |   |   |   |   |   |   |   |   |   |   |   |   |   |   |   |   |
|        | Reset Value |          |    |    |    |    |    |    |    |    |    |    |    | 0            | 0          | 0   | 0           | 0        | 0        | 0           | 0           | 0  | 0      | 0      | 0        | 0 | 0 | 0 | 0 | 0 | 0 | 0 | 0 | 0 | 0 | 0 | 0 | 0 | 0 | 0 | 0 | 0 | 0 | 0 | 0 |   |   |
| 04Ch   | TIMx_DADDR  | Reserved |    |    |    |    |    |    |    |    |    |    |    | BURST[15:0]  |            |     |             |          |          |             |             |    |        |        |          |   |   |   |   |   |   |   |   |   |   |   |   |   |   |   |   |   |   |   |   |   |   |
|        | Reset Value |          |    |    |    |    |    |    |    |    |    |    |    | 0            | 0          | 0   | 0           | 0        | 0        | 0           | 0           | 0  | 0      | 0      | 0        | 0 | 0 | 0 | 0 | 0 | 0 | 0 | 0 | 0 | 0 | 0 | 0 | 0 | 0 | 0 | 0 | 0 | 0 | 0 | 0 |   |   |
| 054h   | TIMx_CCMOD3 | Reserved |    |    |    |    |    |    |    |    |    |    |    | OC6EN        | OC6MD[2:0] |     | OC6PEN      | OC6FEN   | Reserved | OC5EN       | OC5MD[2:0]  |    | OC5PEN | OC5FEN | Reserved |   |   |   |   |   |   |   |   |   |   |   |   |   |   |   |   |   |   |   |   |   |   |
|        | Reset Value |          |    |    |    |    |    |    |    |    |    |    |    | 0            | 0          | 0   | 0           | 0        | 0        | 0           | 0           | 0  | 0      | 0      | 0        | 0 | 0 | 0 | 0 | 0 | 0 | 0 | 0 | 0 | 0 | 0 | 0 | 0 | 0 | 0 | 0 | 0 | 0 | 0 | 0 |   |   |
| 058h   | TIMx_CCDAT5 | Reserved |    |    |    |    |    |    |    |    |    |    |    | CCDAT5[15:0] |            |     |             |          |          |             |             |    |        |        |          |   |   |   |   |   |   |   |   |   |   |   |   |   |   |   |   |   |   |   |   |   |   |
|        | Reset Value |          |    |    |    |    |    |    |    |    |    |    |    | 0            | 0          | 0   | 0           | 0        | 0        | 0           | 0           | 0  | 0      | 0      | 0        | 0 | 0 | 0 | 0 | 0 | 0 | 0 | 0 | 0 | 0 | 0 | 0 | 0 | 0 | 0 | 0 | 0 | 0 | 0 | 0 |   |   |
| 05Ch   | TIMx_CCDAT6 | Reserved |    |    |    |    |    |    |    |    |    |    |    | CCDAT6[15:0] |            |     |             |          |          |             |             |    |        |        |          |   |   |   |   |   |   |   |   |   |   |   |   |   |   |   |   |   |   |   |   |   |   |
|        | Reset Value |          |    |    |    |    |    |    |    |    |    |    |    | 0            | 0          | 0   | 0           | 0        | 0        | 0           | 0           | 0  | 0      | 0      | 0        | 0 | 0 | 0 | 0 | 0 | 0 | 0 | 0 | 0 | 0 | 0 | 0 | 0 | 0 | 0 | 0 | 0 | 0 | 0 | 0 |   |   |

### 9.4.2 Control Register 1 (TIMx\_CTRL1)

Offset address: 0x00

Reset value: 0x0000 0000

|          |          |    |       |           |           |   |       |             |   |     |       |      |       |       |        |    |           |
|----------|----------|----|-------|-----------|-----------|---|-------|-------------|---|-----|-------|------|-------|-------|--------|----|-----------|
| Reserved |          |    |       |           |           |   |       |             |   |     |       |      |       |       | PBKPEN |    | LOCKUP EN |
|          |          |    |       |           |           |   |       |             |   |     |       |      |       |       | rw     | rw | 0         |
| 15       | 14       | 12 |       | 11        | 10        | 9 | 8     | 7           | 6 | 5   | 4     | 3    | 2     | 1     |        | 0  |           |
| CLRSEL   | Reserved |    | CISEL | IOM BKPEN | CLKD[1:0] |   | ARPEN | CAMSEL[1:0] |   | DIR | ONEPM | UPRS | UPDIS | CNTEN |        |    |           |
| rw       |          |    | rw    | rw        | rw        |   | rw    | rw          |   | rw  | rw    | rw   | rw    | rw    |        |    |           |

| Bit Field | Name     | Description                                  |
|-----------|----------|--|
| 31:18     | Reserved | Reserved, the reset value must be maintained |
| 17        | PBKPEN   | PVD as BKP enable                            |

| Bit Field | Name        | Description   |
|-----------|-------------|---|
|           |             | 0: Disable<br>1: Enable   |
| 16        | LBKPEN      | LockUp as BKP enable<br>0: Disable<br>1: Enable   |
| 15        | CLRSEL      | OCxREF clear selection<br>0: Select the external OCxREF clear from ETR<br>1: Select the internal OCxREF clear from comparator   |
| 14:12     | Reserved    | Reserved, the reset value must be maintained  |
| 11        | C1SEL       | Channel 1 selection<br>0: Select external CH1 signal from IOM<br>1: Select internal CH1 signal from COMP  |
| 10        | IOMBKPEN    | Enabling IOM as BKP<br>0: Enable<br>1: Disable  |
| 9:8       | CLKD[1:0]   | Clock division<br>CLKD[1:0] indicates the division ratio between CK_INT (timer clock) and DTS (clock used for dead-time generator and digital filters (ETR, TIX))<br>00: $t_{DTS} = t_{CK\_INT}$<br>01: $t_{DTS} = 2 \times t_{CK\_INT}$<br>10: $t_{DTS} = 4 \times t_{CK\_INT}$<br>11: Reserved, do not use this configuration   |
| 7         | ARPEN       | ARPEN: Auto-reload preload enable<br>0: Shadow register disable for TIMx_AR register<br>1: Shadow register enable for TIMx_AR register  |
| 6:5       | CAMSEL[1:0] | Center-aligned mode selection<br>00: Edge-aligned mode. TIMx_CTRL1.DIR specifies up-counting or down-counting.<br>01: Center-aligned mode 1. The counter counts in center-aligned mode, and the output compare interrupt flag bit is set to 1 when down-counting.<br>10: Center-aligned mode 2. The counter counts in center-aligned mode, and the output compare interrupt flag bit is set to 1 when up-counting.<br>11: Center-aligned mode 3. The counter counts in center-aligned mode, and the output compare interrupt flag bit is set to 1 when up-counting or down-counting.<br><i>Note: Switching from edge-aligned mode to center-aligned mode is not allowed when the counter is still enabled (TIMx_CTRL1.CNTEN = 1).</i> |
| 4         | DIR         | Direction<br>0: Up-counting<br>1: Down-counting<br><i>Note: This bit is read-only when the counter is configured in center-aligned mode or encoder mode.</i>  |
| 3         | ONEPM       | One-pulse mode  |

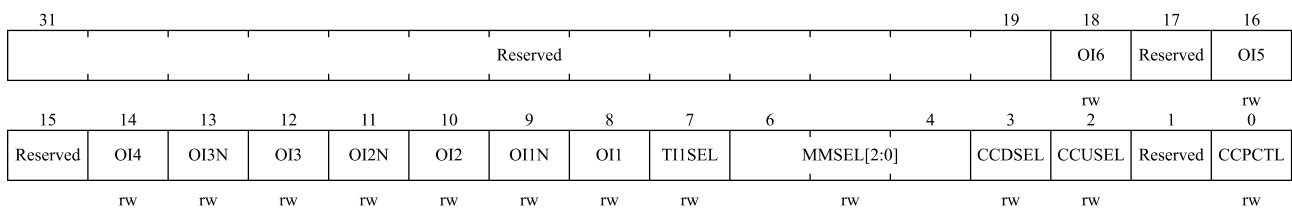


| Bit Field | Name  | Description   |
|-----------|-------|---|
|           |       | <p>0: Disable one-pulse mode, the counter counts are not affected when an update event occurs.</p> <p>1: Enable one-pulse mode, the counter stops counting when the next update event occurs (clearing TIMx_CTRL1.CNTEN bit)</p>  |
| 2         | UPRS  | <p>Update request source</p> <p>This bit is used to select the UEV event sources by software.</p> <p>0: If update interrupt or DMA request is enabled, any of the following events will generate an update interrupt or DMA request:</p> <ul style="list-style-type: none"> <li>– Counter overflow/underflow</li> <li>– The TIMx_EVTGEN.UDGN bit is set</li> <li>– Update generation from the slave mode controller</li> </ul> <p>1: If update interrupt or DMA request is enabled, only counter overflow/underflow will generate update interrupt or DMA request</p>   |
| 1         | UPDIS | <p>Update disable</p> <p>This bit is used to enable/disable the Update event (UEV) events generation by software.</p> <p>0: Enable UEV. UEV will be generated if one of following condition been fulfilled:</p> <ul style="list-style-type: none"> <li>– Counter overflow/underflow</li> <li>– The TIMx_EVTGEN.UDGN bit is set</li> <li>– Update generation from the slave mode controller</li> </ul> <p>Shadow registers will update with preload value.</p> <p>1: UEV disabled. No update event is generated, and the shadow registers (AR, PSC, and CCDATx) keep their values. If the TIMx_EVTGEN.UDGN bit is set or a hardware reset is issued by the slave mode controller, the counter and prescaler are reinitialized.</p> |
| 0         | CNTEN | <p>Counter Enable</p> <p>0: Disable counter</p> <p>1: Enable counter</p> <p><i>Note: external clock, gating mode and encoder mode can only operate after TIMx_CTRL1.CNTEN bit is set in the software. Trigger mode can automatically set TIMx_CTRL1.CNTEN bit by hardware.</i></p>  |

### 9.4.3 Control Register 2 (TIMx\_CTRL2)

Offset address: 0x04

Reset value: 0x0000 0000



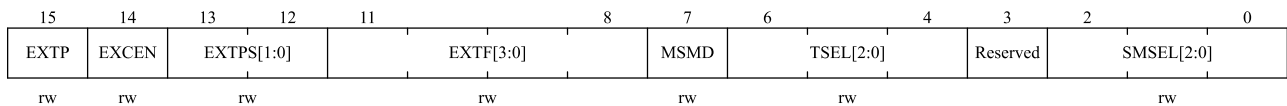
| Bit Field | Name       | Description  |
|-----------|------------|--|
| 31:19     | Reserved   | Reserved, the reset value must be maintained   |
| 18        | OI6        | Output idle state 6 (OC6 output). See TIMx_CTRL2.OI1 bit.  |
| 17        | Reserved   | Reserved, the reset value must be maintained   |
| 16        | OI5        | Output idle state 5 (OC5 output). See TIMx_CTRL2.OI1 bit.  |
| 15        | Reserved   | Reserved, the reset value must be maintained   |
| 14        | OI4        | Output idle state 4 (OC4 output). See TIMx_CTRL2.OI1 bit.  |
| 13        | OI3N       | Output idle state 3 (OC3N output). See TIMx_CTRL2.OI1N bits.   |
| 12        | OI3        | Output idle state 3 (OC3 output). See TIMx_CTRL2.OI1 bit.  |
| 11        | OI2N       | Output idle state 2 (OC2N output). See TIMx_CTRL2.OI1N bits.   |
| 10        | OI2        | Output idle state 2 (OC2 output). See TIMx_CTRL2.OI1 bit.  |
| 9         | OI1N       | Output Idle state 1 (OC1N Output)<br>0: When TIMx_BKDT.MOEN = 0, after dead-time OC1N = 0<br>1: When TIMx_BKDT.MOEN = 0, after dead-time OC1N = 1  |
| 8         | OI1        | Output Idle state 1<br>0: When TIMx_BKDT.MOEN = 0, if OC1N is implemented, after dead-time OC1 = 0<br>1: When TIMx_BKDT.MOEN = 0, if OC1N is implemented, after dead-time OC1 = 1  |
| 7         | TI1SEL     | TI1 selection<br>0: TIMx_CH1 pin connected to TI1 input.<br>1: TIMx_CH1, TIMx_CH2, and TIMx_CH3 pins are XOR connected to the TI1 input.   |
| 6:4       | MMSEL[2:0] | Master Mode Selection<br>These 3 bits (TIMx_CTRL2.MMSEL [2:0]) are used to select the synchronization information (TRGO) sent to the slave timer in the master mode. Possible combinations are as follows:<br>000: Reset –When the TIMx_EVTGEN.UDGN is set or a reset is generated by the slave mode controller, a TRGO pulse occurs. And in the latter case, the signal on TRGO is delayed compared to the actual reset.<br>001: Enable - The TIMx_CTRL1.CNTEN bit is used as the trigger output (TRGO). Sometimes you need to start multiple timers at the same time or enable slave timer for a period of time.<br>The counter enable signal is set when TIMx_CTRL1.CNTEN bit is set or the trigger input in gated mode is high.<br>When the counter enable signal is controlled by the trigger input, there is a delay on TRGO except if the master/slave mode is selected (see the description of the TIMx_SMCTRL.MSMD bit).<br>010: Update - The update event is selected as the trigger output (TRGO). For example, a master timer clock can be used as a slave timer prescaler.<br>011: Compare pulse - Triggers the output to send a positive pulse (TRGO) when the TIMx_STS.CC1ITF is to be set (even if it is already high), when a capture or a comparison succeeds.<br>100: Compare - OC1REF signal is used as the trigger output (TRGO).<br>101: Compare - OC2REF signal is used as the trigger output (TRGO). |

| Bit Field | Name     | Description   |
|-----------|----------|---|
|           |          | 110: Compare - OC3REF signal is used as the trigger output (TRGO).<br>111: Compare - OC4REF signal is used as the trigger output (TRGO).  |
| 3         | CCDSEL   | Capture/compare DMA selection<br>0: When a CCx event occurs, a DMA request for CCx is sent.<br>1: When an update event occurs, a DMA request for CCx is sent.   |
| 2         | CCUSEL   | Capture/compare control update selection<br>0: If TIMx_CTRL2.CCPCTL = 1, they can only be updated by setting CCUDGN bits<br>1: If TIMx_CTRL2.CCPCTL = 1, they can be updated by setting CCUDGN bits or a rising edge on TRGI.<br><i>Note: This bit only applied to channels with complementary outputs.</i>   |
| 1         | Reserved | Reserved, the reset value must be maintained  |
| 0         | CCPCTL   | Capture/ Compare preloaded control<br>0: No preloading of CCxEN, CCxNEN and OCxMD bits occurs.<br>1: Preloading of CCxEN, CCxNEN and OCxMD bits occurs. they are updated only when a commutation event COM occurs (TIMx_EVTGEN.CCUDGN bit set or rising edge on TRGI depending on CCUSEL bit)<br><i>Note: This bit only applied to channels with complementary outputs.</i> |

#### 9.4.4 Slave Mode Control Register (TIMx\_SMCTRL)

Offset address: 0x08

Reset value: 0x0000



| Bit Field | Name  | Description  |
|-----------|-------|--|
| 15        | EXTP  | External trigger polarity<br>This bit is used to select whether the trigger operation is to use ETR or the inversion of ETR.<br>0: ETR active at high level or rising edge.<br>1: ETR active at low level or falling edge.   |
| 14        | EXCEN | External clock enable<br>This bit is used to enable external clock mode 2, and the counter is driven by any effective edge on the ETRF signal in this mode.<br>0: External clock mode 2 disable.<br>1: External clock mode 2 enable.<br><i>Note 1: When external clock mode 1 and external clock mode 2 are enabled at the same time, the input of the external clock is ETRF.</i> |

| Bit Field | Name       | Description   |
|-----------|------------|---|
|           |            | <p><i>Note 2: The following slave modes can be used simultaneously with external clock mode 2: reset mode, gated mode and trigger mode; However, TRGI cannot connect to ETRF (TIMx_SMCTRL.TSEL ≠ '111').</i></p> <p><i>Note 3: Setting the TIMx_SMCTRL.EXCEN bit has the same effect as selecting external clock mode 1 and connecting TRGI to ETRF (TIMx_SMCTRL.SMSEL = 111 and TIMx_SMCTRL.TSEL = 111).</i></p>   |
| 13:12     | EXTPS[1:0] | <p>External trigger prescaler</p> <p>The frequency of the external trigger signal ETRP must be at most 1/4 of TIMxCLK frequency. When a faster external clock is input, a prescaler can be used to reduce the frequency of ETRP.</p> <p>00: Prescaler disable<br/>           01: ETRP frequency divided by 2<br/>           10: ETRP frequency divided by 4<br/>           11: ETRP frequency divided by 8</p>  |
| 11:8      | EXTF[3:0]  | <p>External trigger filter</p> <p>These bits are used to define the frequency at which the ETRP signal is sampled and the bandwidth of the ETRP digital filtering. In effect, the digital filter is an event counter that generates a validate output after consecutive N events are recorded.</p> <p>0000: No filter, sampling at <math>f_{DTS}</math><br/>           0001: <math>f_{SAMPLING} = f_{CK\_INT}</math>, N = 2<br/>           0010: <math>f_{SAMPLING} = f_{CK\_INT}</math>, N = 4<br/>           0011: <math>f_{SAMPLING} = f_{CK\_INT}</math>, N = 8<br/>           0100: <math>f_{SAMPLING} = f_{DTS}/2</math>, N = 6<br/>           0101: <math>f_{SAMPLING} = f_{DTS}/2</math>, N = 8<br/>           0110: <math>f_{SAMPLING} = f_{DTS}/4</math>, N = 6<br/>           0111: <math>f_{SAMPLING} = f_{DTS}/4</math>, N = 8<br/>           1000: <math>f_{SAMPLING} = f_{DTS}/8</math>, N = 6<br/>           1001: <math>f_{SAMPLING} = f_{DTS}/8</math>, N = 8<br/>           1010: <math>f_{SAMPLING} = f_{DTS}/16</math>, N = 5<br/>           1011: <math>f_{SAMPLING} = f_{DTS}/16</math>, N = 6<br/>           1100: <math>f_{SAMPLING} = f_{DTS}/16</math>, N = 8<br/>           1101: <math>f_{SAMPLING} = f_{DTS}/32</math>, N = 5<br/>           1110: <math>f_{SAMPLING} = f_{DTS}/32</math>, N = 6<br/>           1111: <math>f_{SAMPLING} = f_{DTS}/32</math>, N = 8</p> |
| 7         | MSMD       | <p>Master/ Slave mode</p> <p>0: No action<br/>           1: Events on the trigger input (TRGI) are delayed to allow a perfect synchronization between the current timer (via TRGO) and its slaves. This is useful when several timers are required to be synchronized to a single external event.</p>   |

| Bit Field | Name       | Description   |
|-----------|------------|---|
| 6:4       | TSEL[2:0]  | <p>Trigger selection</p> <p>These 3 bits are used to select the trigger input of the synchronous counter.</p> <p>000: Internal trigger 0 (ITR0) 100: TI1 edge detector (TI1F_ED)<br/>                     001: Internal trigger 1 (ITR1) 101: Filtered timer input 1 (TI1FP1)<br/>                     010: Internal trigger 2 (ITR2) 110: Filtered timer input 2 (TI2FP2)<br/>                     011: Internal trigger 3 (ITR3) 111: External triggered Input (ETRF)</p> <p>For more details on ITRx, see Table 9-3 below.</p> <p><i>Note: These bits must be changed only when not in use (e. g. TIMx_SMCTRL.SMSEL=000) to avoid false edge detection at the transition.</i></p>  |
| 3         | Reserved   | Reserved, the reset value must be maintained  |
| 2:0       | SMSEL[2:0] | <p>Slave mode selection</p> <p>When an external signal is selected, the effective edge of the trigger signal (TRGI) is linked to the selected external input polarity (see input control register and control register description)</p> <p>000: Disable slave mode. If TIMx_CTRL1.CNTEN = 1, the prescaler is driven directly by the internal clock.</p> <p>001: Encoder mode 1. According to the level of TI2FP2, the counter up-counting or down-counting on the edge of TI1FP1.</p> <p>010: Encoder mode 2. According to the level of TI1FP1, the counter up-counting or down-counting on the edge of TI2FP2.</p> <p>011: Encoder mode 3. According to the input level of another signal, the counter up-counting or down-counting on the edges of TI2FP1 and TI2FP2.</p> <p>100: Reset mode. On the rising edge of the selected trigger input (TRGI), the counter is reinitialized and the shadow register is updated.</p> <p>101: Gated mode. When the trigger input (TRGI) is high, the clock of the counter is enabled. Once the trigger input becomes low, the counter stops counting, but is not reset. In this mode, the start and stop of the counter are controlled.</p> <p>110: Trigger mode. When a rising edge occurs on the trigger input (TRGI), the counter is started but not reset. In this mode, only the start of the counter is controlled.</p> <p>111: External clock mode 1. The counter is clocked by the rising edge of the selected trigger input (TRGI).</p> <p><i>Note: Do not use gated mode if TI1F_ED is selected as the trigger input (TIMx_SMCTRL.TSEL=100). This is because TI1F_ED outputs a pulse for each TI1F transition, whereas gated mode checks the level of the triggered input.</i></p> |

**Table 9-3 TIMx Internal Trigger Connection**

| Slave Timer | ITR0 (TSEL = 000) | ITR1 (TSEL = 001) | ITR2 (TSEL = 010) | ITR3 (TSEL = 011) |
|-------------|-------------------|-------------------|-------------------|-------------------|
| <b>TIM1</b> | NA                | NA                | TIM3              | NA                |
| <b>TIM8</b> | TIM1              | NA                | NA                | NA                |

### 9.4.5 DMA/Interrupt Enable Registers (TIMx\_DINTEN)

Offset address: 0x0C

Reset value: 0x0000

|          |      |        |        |        |        |        |      |      |      |        |        |        |        |        |      |
|----------|------|--------|--------|--------|--------|--------|------|------|------|--------|--------|--------|--------|--------|------|
| 15       | 14   | 13     | 12     | 11     | 10     | 9      | 8    | 7    | 6    | 5      | 4      | 3      | 2      | 1      | 0    |
| Reserved | TDEN | COMDEN | CC4DEN | CC3DEN | CC2DEN | CC1DEN | UDEN | BIEN | TIEN | COMIEN | CC4IEN | CC3IEN | CC2IEN | CC1IEN | UIEN |
|          | rw   | rw     | rw     | rw     | rw     | rw     | rw   | rw   | rw   | rw     | rw     | rw     | rw     | rw     | rw   |

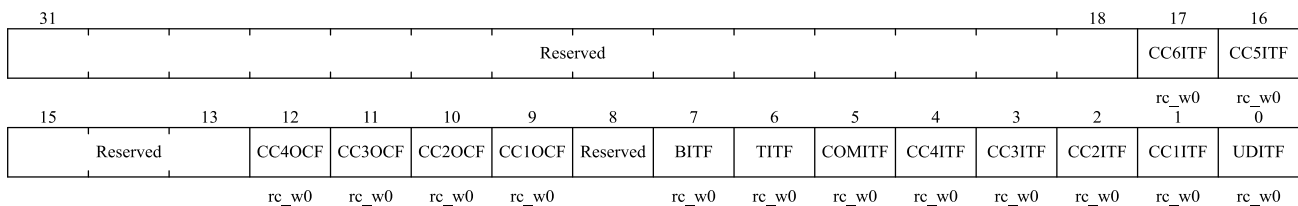
| Bit Field | Name     | Description   |
|-----------|----------|---|
| 15        | Reserved | Reserved, the reset value must be maintained  |
| 14        | TDEN     | Trigger DMA request enable<br>0: Disable trigger DMA request<br>1: Enable trigger DMA request                               |
| 13        | COMDEN   | COM DMA request enable<br>0: Disable COM DMA request<br>1: Enable COM DMA request   |
| 12        | CC4DEN   | Capture/Compare 4 DMA request enable<br>0: Disable capture/compare 4 DMA request<br>1: Enable capture/compare 4 DMA request |
| 11        | CC3DEN   | Capture/Compare 3 DMA request enable<br>0: Disable capture/compare 3 DMA request<br>1: Enable capture/compare 3 DMA request |
| 10        | CC2DEN   | Capture/Compare 2 DMA request enable<br>0: Disable capture/compare 2 DMA request<br>1: Enable capture/compare 2 DMA request |
| 9         | CC1DEN   | Capture/Compare 1 DMA request enable<br>0: Disable capture/compare 1 DMA request<br>1: Enable capture/compare 1 DMA request |
| 8         | UDEN     | Update DMA request enable<br>0: Disable update DMA request<br>1: Enable update DMA request                                  |
| 7         | BIEN     | Break interrupt enable<br>0: Disable break interrupt<br>1: Enable break interrupt   |
| 6         | TIEN     | Trigger interrupt enable<br>0: Disable trigger interrupt<br>1: Enable trigger interrupt                                     |
| 5         | COMIEN   | COM interrupt enable<br>0: Disable COM interrupt<br>1: Enable COM interrupt   |

| Bit Field | Name   | Description  |
|-----------|--------|--|
| 4         | CC4IEN | Capture/Compare 4 interrupt enable<br>0: Disable capture/compare 4 interrupt<br>1: Enable capture/compare 4 interrupt    |
| 3         | CC3IEN | Capture/Compare 3 interrupt enable<br>0: Disable capture/compare 3 interrupt<br>1: Enable capture/compare 3 interrupts   |
| 2         | CC2IEN | Capture/Compare 2 interrupt enable<br>0: Disable capture/compare 2 interrupt<br>1: Enables capture/compare 2 interrupts  |
| 1         | CC1IEN | Capture/Compare 1 interrupt enable<br>0: Disable capture/compare 1 interrupt<br>1: Enables capture/comparing 1 interrupt |
| 0         | UIEN   | Update interrupt enable<br>0: Disable update interrupt<br>1: Enables update interrupt                                    |

### 9.4.6 Status Registers (TIMx\_STS)

Offset address: 0x10

Reset value: 0x0000 0000



| Bit Field | Name     | Description   |
|-----------|----------|---|
| 31: 18    | Reserved | Reserved, the reset value must be maintained                            |
| 17        | CC6ITF   | Capture/Compare 6 interrupt flag<br>See TIMx_STS.CC1ITF description.    |
| 16        | CC5ITF   | Capture/Compare 5 interrupt flag<br>See TIMx_STS.CC1ITF description.    |
| 15: 13    | Reserved | Reserved, the reset value must be maintained                            |
| 12        | CC4OCF   | Capture/Compare 4 overcapture flag<br>See TIMx_STS.CC1OCF description.  |
| 11        | CC3OCF   | Capture/Compare 3 overcapture flag<br>See TIMx_STS.CC1OCF description.  |
| 10        | CC2OCF   | Capture/Compare 2 overcapture flags<br>See TIMx_STS.CC1OCF description. |

| Bit Field | Name     | Description   |
|-----------|----------|---|
| 9         | CC1OCF   | <p>Capture/Compare 1 overcapture flag</p> <p>This bit is set by hardware only when the corresponding channel is configured in input capture mode. Cleared by software writing 0.</p> <p>0: No overcapture occurred</p> <p>1: TIMx_STS.CC1ITF was already set when the value of the counter has been captured in the TIMx_CCDAT1 register.</p>   |
| 8         | Reserved | Reserved, the reset value must be maintained  |
| 7         | BITF     | <p>Break interrupt flag</p> <p>This bit is set by hardware once the brake input is active. This bit is cleared by software when the brake input becomes inactive.</p> <p>0: No break event occurred</p> <p>1: An active level has been detected</p>   |
| 6         | TITF     | <p>Trigger interrupt flag</p> <p>This bit is set by hardware when an effective edge is detected on the TRGI input when the slave mode controller is in a mode other than gated. This bit is set by hardware when any edge in gated mode is detected. This bit is cleared by software.</p> <p>0: No trigger event occurred</p> <p>1: Trigger interrupt occurred</p>  |
| 5         | COMITF   | <p>COM interrupt flag</p> <p>This bit is set by hardware once a COM event is generated (when TIMx_CCEN.CCxEN, TIMx_CCEN.CCxNEN, TIMx_CCMOD1.OCxMD have been updated). This bit is cleared by software.</p> <p>0: No COM event occurred</p> <p>1: COM interrupt pending</p>  |
| 4         | CC4ITF   | <p>Capture/Compare 4 interrupt flag</p> <p>See TIMx_STS.CC1ITF description.</p>   |
| 3         | CC3ITF   | <p>Capture/Compare 3 interrupt flag</p> <p>See TIMx_STS.CC1ITF description.</p>   |
| 2         | CC2ITF   | <p>Capture/Compare 2 interrupt flag</p> <p>See TIMx_STS.CC1ITF description.</p>   |
| 1         | CC1ITF   | <p>Capture/Compare 1 interrupt flag</p> <p><b>When the corresponding channel of CC1 is in output mode:</b></p> <p>Except in center-aligned mode, this bit is set by hardware when the counter value is the same as the compare value (see TIMx_CTRL1.CAMSEL bit description). This bit is cleared by software.</p> <p>0: No match occurred.</p> <p>1: The value of TIMx_CNT is the same as the value of TIMx_CCDAT1.</p> <p>When the value of TIMx_CCDAT1 is greater than the value of TIMx_AR, the TIMx_STS.CC1ITF bit will go high if the counter overflows (in up-counting and up/down-counting modes) and underflows in down-counting mode.</p> <p><b>When the corresponding channel of CC1 is in input mode:</b></p> |

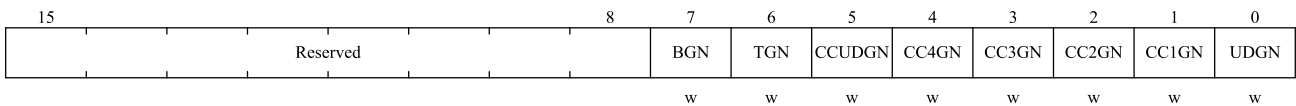


| Bit Field | Name  | Description   |
|-----------|-------|---|
|           |       | <p>This bit is set by hardware when the capture event occurs. This bit is cleared by software or by reading TIMx_CCDAT1.</p> <p>0: No input capture occurred.</p> <p>1: Input capture occurred. Counter value has captured in the TIMx_CCDAT1. An edge with the same polarity as selected has been detected on IC1.</p>   |
| 0         | UDITF | <p>Update interrupt flag</p> <p>This bit is set by hardware when an update event occurs under the following conditions:</p> <ul style="list-style-type: none"> <li>– When TIMx_CTRL1.UPDIS = 0, and repeat counter value overflow or underflow (An update event is generated when the repeat counter equals 0).</li> <li>– When TIMx_CTRL1.UPRS = 0, TIMx_CTRL1.UPDIS = 0, and set the TIMx_EVTGEN.UDGN bit by software to reinitialize the CNT.</li> <li>– When TIMx_CTRL1.UPRS = 0, TIMx_CTRL1.UPDIS = 0, and the counter CNT is reinitialized by the trigger event. (See TIMx_SMCTRL Register description)</li> </ul> <p>This bit is cleared by software.</p> <p>0: No update event occurred</p> <p>1: Update interrupt occurred</p> |

**9.4.7 Event Generation Registers (TIMx\_EVTGEN)**

Offset address: 0x14

Reset values: 0x0000



| Bit Field | Name     | Description  |
|-----------|----------|--|
| 15: 8     | Reserved | Reserved, the reset value must be maintained   |
| 7         | BGN      | <p>Break generation</p> <p>This bit can generate a brake event when set by software. And at this time TIMx_BKDT.MOEN = 0, TIMx_STS.BITF = 1, if the corresponding interrupt and DMA are enabled, the corresponding interrupt and DMA will be generated. This bit is automatically cleared by hardware.</p> <p>0: No action</p> <p>1: Generated a break event</p> |
| 6         | TGN      | <p>Trigger generation</p> <p>This bit can generate a trigger event when set by software. And at this time TIMx_STS.TITF = 1, if the corresponding interrupt and DMA are enabled, the corresponding interrupt and DMA will be generated. This bit is automatically cleared by hardware.</p> <p>0: No action</p> <p>1: Generated a trigger event</p>               |

| Bit Field | Name   | Description  |
|-----------|--------|--|
| 5         | CCUDGN | <p>Capture/Compare control update generation</p> <p>This bit is set by software. And if TIMx_CTRL2.CCPCTL = 1 at this time, the CCxEN, CCxNEN and OCxMD bits are allowed to be updated. This bit is automatically cleared by hardware.</p> <p>0: No action<br/>1: Generated a COM event</p> <p><i>Note: This bit is only valid for channels with complementary outputs.</i></p>  |
| 4         | CC4GN  | <p>Capture/Compare 4 generation</p> <p>See TIMx_EVTGEN.CC1GN description.</p>  |
| 3         | CC3GN  | <p>Capture/Compare 3 generation</p> <p>See TIMx_EVTGEN.CC1GN description.</p>  |
| 2         | CC2GN  | <p>Capture/Compare 2 generation</p> <p>See TIMx_EVTGEN.CC1GN description.</p>  |
| 1         | CC1GN  | <p>Capture/Compare 1 generation</p> <p>This bit can generate a capture/compare event when set by software. This bit is automatically cleared by hardware.</p> <p>When the corresponding channel of CC1 is in output mode:<br/>The TIMx_STS.CC1ITF flag will be pulled high, if the corresponding interrupt and DMA are enabled, the corresponding interrupt and DMA will be generated.</p> <p>When the corresponding channel of CC1 is in input mode:<br/>TIMx_CC1DAT1 will capture the current counter value, and the TIMx_STS.CC1ITF flag will be pulled high, if the corresponding interrupt and DMA are enabled, the corresponding interrupt and DMA will be generated. If The TIMx_STS.CC1ITF is already pulled high, pull TIMx_STS.CC1OCF high.</p> <p>0: No action<br/>1: Generated a CC1 capture/compare event</p> |
| 0         | UDGN   | <p>Update generation</p> <p>This bit can generate an update event when set by software. And at this time the counter will be reinitialized, the prescaler counter will be cleared, the counter will be cleared in center-aligned or up-counting mode, but take TIMx_AR in down-counting mode the value of the register. This bit is automatically cleared by hardware.</p> <p>0: No action<br/>1: Generated an update event</p>  |

#### 9.4.8 Capture/Compare Mode Register 1 (TIMx\_CCMOD1)

Offset address: 0x18

Reset value: 0x0000

Channels can be used for input (capture mode) or output (compare mode), and the direction of the channel is defined by the corresponding CCxSEL bit. The other bits of the register act differently in input and output modes. OCx describes the function of a channel in output mode, ICx describes the function of a channel in input mode. Hence, please note that the same bit can have different meanings for output mode and for input mode.

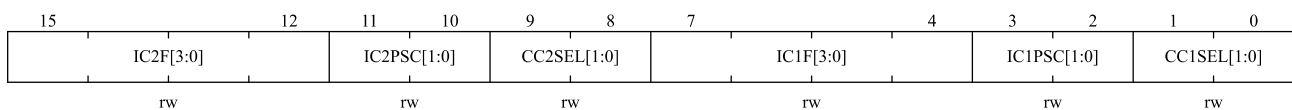
Output compare mode:

|        |           |    |        |        |             |   |        |           |   |        |        |             |   |
|--------|-----------|----|--------|--------|-------------|---|--------|-----------|---|--------|--------|-------------|---|
| 15     | 14        | 12 | 11     | 10     | 9           | 8 | 7      | 6         | 4 | 3      | 2      | 1           | 0 |
| OC2CEN | OC2M[2:0] |    | OC2PEN | OC2FEN | CC2SEL[1:0] |   | OC1CEN | OC1M[2:0] |   | OC1PEN | OC1FEN | CC1SEL[1:0] |   |
| rw     | rw        |    | rw     | rw     | rw          |   | rw     | rw        |   | rw     | rw     | rw          |   |

| Bit Field | Name        | Description  |
|-----------|-------------|--|
| 15        | OC2CEN      | Output Compare 2 clear enable  |
| 14:12     | OC2MD[2:0]  | Output Compare 2 mode  |
| 11        | OC2PEN      | Output Compare 2 preload enable  |
| 10        | OC2FEN      | Output Compare 2 fast enable   |
| 9:8       | CC2SEL[1:0] | Capture/compare 2 selection<br>These bits are used to select the input/output and input mapping of the channel<br>00: CC2 channel is configured as output<br>01: CC2 channel is configured as input, IC2 is mapped on TI2<br>10: CC2 channel is configured as input, IC2 is mapped on TI1<br>11: CC2 channel is configured as input, IC2 is mapped on TRC. This mode is only active when the internal trigger input is selected by TIMx_SMCTRL.TSEL.<br><i>Note: CC2SEL is writable only when the channel is off (TIMx_CCEN.CC2EN = 0).</i>  |
| 7         | OC1CEN      | Output Compare 1 clear enable<br>0: OC1REF is not affected by ETRF input level<br>1: OC1REF is cleared immediately when the ETRF input level is detected as high   |
| 6:4       | OC1MD[2:0]  | Output Compare 1 mode<br>These bits are used to manage the output reference signal OC1REF, which determines the values of OC1 and OC1N, and is valid at high levels, while the active levels of OC1 and OC1N depend on the TIMx_CCEN.CC1P and TIMx_CCEN.CC1NP bits.<br>000: Frozen. Comparison between TIMx_CCDAT1 register and counter TIMx_CNT has no effect on OC1REF signal.<br>001: Set channel 1 to the active level on match. When TIMx_CCDAT1 = TIMx_CNT, OC1REF signal will be forced high.<br>010: Set channel 1 as inactive level on match. When TIMx_CCDAT1 = TIMx_CNT, OC1REF signal will be forced low.<br>011: Toggle. When TIMx_CCDAT1 = TIMx_CNT, OC1REF signal will be toggled.<br>100: Force to inactive level. OC1REF signal is forced low.<br>101: Force to active level. OC1REF signal is forced high.<br>110: PWM mode 1 - In up-counting mode, if TIMx_CNT < TIMx_CCDAT1, OC1REF signal of channel 1 is high, otherwise it is low. In down-counting mode, if TIMx_CNT > TIMx_CCDAT1, OC1REF signal of channel 1 is low, otherwise it is high.<br>111: PWM mode 2 - In up-counting mode, if TIMx_CNT < TIMx_CCDAT1, OC1REF signal of channel 1 is low, otherwise it is high. In down-counting mode, if TIMx_CNT > TIMx_CCDAT1, OC1REF signal of channel 1 is high, otherwise it is low.<br><i>Note: In PWM mode 1 or PWM mode 2, the OC1REF level changes only when the comparison result changes or when the output compare mode is switched from frozen mode to</i> |

| Bit Field | Name        | Description   |
|-----------|-------------|---|
|           |             | <i>PWM mode.</i>  |
| 3         | OC1PEN      | Output Compare 1 preload enable<br>0: Disable preload function of TIMx_CCDAT1 register. Supports write operations to TIMx_CCDAT1 register at any time, and the written value is effective immediately.<br>1: Enable preload function of TIMx_CCDAT1 register. Only read and write operations to preload registers. When an update event occurs, the value of TIMx_CCDAT1 is loaded into the active register.<br><i>Note: Only when TIMx_CTRL1.ONEPM = 1 (In one-pulse mode), PWM mode can be used without verifying the preload register, otherwise no other behavior can be predicted.</i>   |
| 2         | OC1FEN      | Output Compare 1 fast enable<br>This bit is used to speed up the response of the CC output to the trigger input event.<br>0: CC1 behaves normally depending on the counter and CCDAT1 values, even if the trigger is ON. The minimum delay for activating CC1 output when an edge occurs on the trigger input is 5 clock cycles.<br>1: An effective edge of the trigger input acts like a comparison match on CC1 output. Therefore, OC is set to the comparison level regardless of the comparison result. The delay time for sampling the trigger input and activating the CC1 output is reduced to 3 clock cycles. OCxFEN only operates if the channel is configured in PWM1 or PWM2 mode. |
| 1: 0      | CC1SEL[1:0] | Capture/compare 1 selection<br>These bits are used to select the input/output and input mapping of the channel<br>00: CC1 channel is configured as output<br>01: CC1 channel is configured as input, IC1 is mapped on TI1<br>10: CC1 channel is configured as input, IC1 is mapped on TI2<br>11: CC1 channels are configured as inputs and IC1 is mapped to TRC. This mode is only active when the internal trigger input is selected by TIMx_SMCTRL.TSEL.<br><i>Note: CC1SEL is writable only when the channel is off (TIMx_CCEN.CCIEN = 0).</i>   |

Input capture mode:



| Bit Field | Name        | Description               |
|-----------|-------------|---------------------------|
| 15:12     | IC2F[3:0]   | Input Capture 2 Filter    |
| 11:10     | IC2PSC[1:0] | Input Capture 2 Prescaler |

| Bit Field | Name        | Description  |
|-----------|-------------|--|
| 9:8       | CC2SEL[1:0] | <p>Capture/Compare 2 selection</p> <p>These bits are used to select the input/output and input mapping of the channel</p> <p>00: CC2 channel is configured as output</p> <p>01: CC2 channel is configured as input, IC2 is mapped on TI2</p> <p>10: CC2 channel is configured as input, IC2 is mapped on TI1</p> <p>11: CC2 channel is configured as input, IC2 is mapped on TRC. This mode is only active when the internal trigger input is selected by TIMx_SMCTRL.TSEL.</p> <p><i>Note: CC2SEL is writable only when the channel is off (TIMx_CCEN.CC2EN = 0).</i></p>   |
| 7:4       | IC1F[3:0]   | <p>Input Capture 1 filter</p> <p>These bits are used to define sampling frequency of TI1 input and the length of digital filter. The digital filter is an event counter that generates an output transition after N events are recorded.</p> <p>0000: No filter, sampling at f<sub>DTS</sub> frequency</p> <p>0001: f<sub>SAMPLING</sub> = f<sub>CK_INT</sub>, N = 2</p> <p>0010: f<sub>SAMPLING</sub> = f<sub>CK_INT</sub>, N = 4</p> <p>0011: f<sub>SAMPLING</sub> = f<sub>CK_INT</sub>, N = 8</p> <p>0100: f<sub>SAMPLING</sub> = f<sub>DTS</sub>/2, N = 6</p> <p>0101: f<sub>SAMPLING</sub> = f<sub>DTS</sub>/2, N = 8</p> <p>0110: f<sub>SAMPLING</sub> = f<sub>DTS</sub>/4, N = 6</p> <p>0111: f<sub>SAMPLING</sub> = f<sub>DTS</sub>/4, N = 8</p> <p>1000: f<sub>SAMPLING</sub> = f<sub>DTS</sub>/8, N = 6</p> <p>1001: f<sub>SAMPLING</sub> = f<sub>DTS</sub>/8, N = 8</p> <p>1010: f<sub>SAMPLING</sub> = f<sub>DTS</sub>/16, N = 5</p> <p>1011: f<sub>SAMPLING</sub> = f<sub>DTS</sub>/16, N = 6</p> <p>1100: f<sub>SAMPLING</sub> = f<sub>DTS</sub>/16, N = 8</p> <p>1101: f<sub>SAMPLING</sub> = f<sub>DTS</sub>/32, N = 5</p> <p>1110: f<sub>SAMPLING</sub> = f<sub>DTS</sub>/32, N = 6</p> <p>1111: f<sub>SAMPLING</sub> = f<sub>DTS</sub>/32, N = 8</p> |
| 3:2       | IC1PSC[1:0] | <p>Input Capture 1 prescaler</p> <p>These bits are used to select the ratio of the prescaler for IC1 (CC1 input).</p> <p>When TIMx_CCEN.CC1EN = 0, the prescaler will be reset.</p> <p>00: No prescaler, capture is done each time an edge is detected on the capture input</p> <p>01: Capture is done once every 2 events</p> <p>10: Capture is done once every 4 events</p> <p>11: Capture is done once every 8 events</p>   |
| 1:0       | CC1SEL[1:0] | <p>Capture/Compare 1 selection</p> <p>These bits are used to select the input/output and input mapping of the channel</p> <p>00: CC1 channel is configured as output</p> <p>01: CC1 channel is configured as input, IC1 is mapped on TI1</p> <p>10: CC1 channel is configured as input, IC1 is mapped on TI2</p> <p>11: CC1 channel is configured as input, IC1 is mapped to TRC. This mode is only active when the internal trigger input is selected by TIMx_SMCTRL.TSEL.</p>  |

| Bit Field | Name | Description   |
|-----------|------|---|
|           |      | <i>Note: CC1SEL is writable only when the channel is off (TIMx_CCEN.CC1EN = 0).</i> |

### 9.4.9 Capture/Compare Mode Register 2 (TIMx\_CCMOD2)

Offset address: 0x1C

Reset value: 0x0000

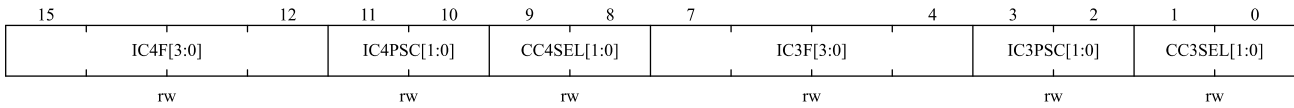
See the description of the CCMOD1 register above

Output comparison mode:

|        |            |    |        |        |             |   |        |            |   |        |        |             |   |
|--------|------------|----|--------|--------|-------------|---|--------|------------|---|--------|--------|-------------|---|
| 15     | 14         | 12 | 11     | 10     | 9           | 8 | 7      | 6          | 4 | 3      | 2      | 1           | 0 |
| OC4CEN | OC4MD[2:0] |    | OC4PEN | OC4FEN | CC4SEL[1:0] |   | OC3CEN | OC3MD[2:0] |   | OC3PEN | OC3FEN | CC3SEL[1:0] |   |
| rw     | rw         |    | rw     | rw     | rw          |   | rw     | rw         |   | rw     | rw     | rw          |   |

| Bit Field | Name        | Description   |
|-----------|-------------|---|
| 15        | OC4CEN      | Output compare 4 clear enable   |
| 14:12     | OC4MD[2:0]  | Output compare 4 mode   |
| 11        | OC4PEN      | Output compare 4 preload enable   |
| 10        | OC4FEN      | Output compare 4 fast enable  |
| 9:8       | CC4SEL[1:0] | Capture/Compare 4 selection<br>These bits are used to select the input/output and input mapping of the channel<br>00: CC4 channel is configured as output<br>01: CC4 channel is configured as input, IC4 is mapped on TI4<br>10: CC4 channel is configured as input, IC4 is mapped on TI3<br>11: CC4 channel is configured as input, IC4 is mapped on TRC. This mode is only active when the internal trigger input is selected by TIMx_SMCTRL.TSEL.<br><i>Note: CC4SEL is writable only when the channel is off (TIMx_CCEN.CC4EN = 0).</i> |
| 7         | OC3CEN      | Output compare 3 clear enable   |
| 6:4       | OC3MD[2:0]  | Output compare 3 mode   |
| 3         | OC3PEN      | Output compare 3 preload enable   |
| 2         | OC3FEN      | Output compare 3 fast enable  |
| 1:0       | CC3SEL[1:0] | Capture/Compare 3 selection<br>These bits are used to select the input/output and input mapping of the channel<br>00: CC3 channel is configured as output<br>01: CC3 channel is configured as input, IC3 is mapped to TI3<br>10: CC3 channel is configured as input, IC3 is mapped on TI4<br>11: CC3 channel is configured as input, IC3 is mapped to TRC. This mode is only active when the internal trigger input is selected by TIMx_SMCTRL.TSEL.<br><i>Note: CC3SEL is writable only when the channel is off (TIMx_CCEN.CC3EN = 0).</i> |

Input capture mode:

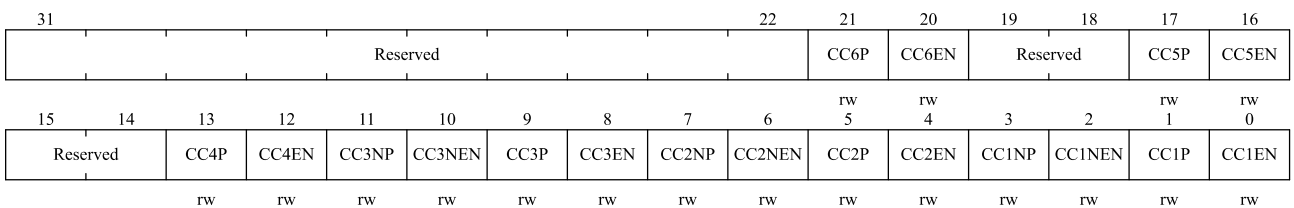


| Bit Field | Name        | Description   |
|-----------|-------------|---|
| 15:12     | IC4F[3:0]   | Input Capture 4 filter  |
| 11:10     | IC4PSC[1:0] | Input Capture 4 Prescaler   |
| 9:8       | CC4SEL[1:0] | Capture/Compare 4 selection<br>These bits are used to select the input/output and input mapping of the channel<br>00: CC4 channel is configured as output<br>01: CC4 channel is configured as input, IC4 is mapped on TI4<br>10: CC4 channel is configured as input, IC4 is mapped on TI3<br>11: CC4 channel is configured as input, IC4 is mapped on TRC. This mode is only active when the internal trigger input is selected by TIMx_SMCTRL.TSEL.<br><i>Note: CC4SEL is writable only when the channel is off (TIMx_CCEN.CC4EN = 0).</i> |
| 7:4       | IC3F[3:0]   | Input Capture 3 filter  |
| 3:2       | IC3PSC[1:0] | Input Capture 3 Prescaler   |
| 1:0       | CC3SEL[1:0] | Capture/compare 3 selection<br>These bits are used to select the input/output and input mapping of the channel<br>00: CC3 channel is configured as output<br>01: CC3 channel is configured as input, IC3 is mapped to TI3<br>10: CC3 channel is configured as input, IC3 is mapped on TI4<br>11: CC3 channel is configured as input, IC3 is mapped to TRC. This mode is only active when the internal trigger input is selected by TIMx_SMCTRL.TSEL.<br><i>Note: CC3SEL is writable only when the channel is off (TIMx_CCEN.CC3EN = 0).</i> |

### 9.4.10 Capture/Compare Enable Registers (TIMx\_CCEN)

Offset address: 0x20

Reset value: 0x0000 0000



| Bit Field | Name     | Description  |
|-----------|----------|--|
| 31:22     | Reserved | Reserved, the reset value must be maintained                         |
| 21        | CC6P     | Capture/Compare 6 output polarity<br>See TIMx_CCEN.CC1P description. |
| 20        | CC6EN    | Capture/Compare 6 output enable                                      |

| Bit Field | Name     | Description   |
|-----------|----------|---|
|           |          | See TIMx_CCEN.CC1EN description.  |
| 19: 18    | Reserved | Reserved, the reset value must be maintained  |
| 17        | CC5P     | Capture/Compare 5 output polarity<br>See TIMx_CCEN.CC1P description.  |
| 16        | CC5EN    | Capture/Compare 5 output enable<br>See TIMx_CCEN.CC1EN description.   |
| 15:14     | Reserved | Reserved, the reset value must be maintained  |
| 13        | CC4P     | Capture/Compare 4 output polarity<br>See TIMx_CCEN.CC1P description.  |
| 12        | CC4EN    | Capture/Compare 4 output enable<br>See TIMx_CCEN.CC1EN description.   |
| 11        | CC3NP    | Capture/Compare 3 Complementary output polarity<br>See TIMx_CCEN.CC1NP description.   |
| 10        | CC3NEN   | Capture/Compare 3 complementary output enable<br>See TIMx_CCEN.CC1NEN description.  |
| 9         | CC3P     | Capture/Compare 3 output polarity<br>See TIMx_CCEN.CC1P description.  |
| 8         | CC3EN    | Capture/Compare 3 output enable<br>See TIMx_CCEN.CC1EN description.   |
| 7         | CC2NP    | Capture/Compare 2 complementary output polarity<br>See TIMx_CCEN.CC1NP description.   |
| 6         | CC2NEN   | Capture/Compare 2 complementary output enable<br>See TIMx_CCEN.CC1NEN description.  |
| 5         | CC2P     | Capture/Compare 2 output polarity<br>See TIMx_CCEN.CC1P description.  |
| 4         | CC2EN    | Capture/Compare 2 output enable<br>See TIMx_CCEN.CC1EN description.   |
| 3         | CC1NP    | Capture/Compare 1 complementary output polarity<br>0: OC1N active high<br>1: OC1N active low  |
| 2         | CC1NEN   | Capture/Compare 1 complementary output enable<br>0: Disable - Disable output OC1N signal. The level of OC1N depends on the value of these bits<br>TIMx_BKDT.MOEN, TIMx_BKDT.OSSI, TIMx_BKDT.OSSR, TIMx_CTRL2.OI1, TIMx_CTRL2.OI1N and TIMx_CCEN.CC1EN.<br>1: Enable - Enable output OC1N signal. The level of OC1N depends on the value of these bits<br>TIMx_BKDT.MOEN, TIMx_BKDT.OSSI, TIMx_BKDT.OSSR, TIMx_CTRL2.OI1, TIMx_CTRL2.OI1N and TIMx_CCEN.CC1EN. |



| Bit Field | Name  | Description   |
|-----------|-------|---|
| 1         | CC1P  | <p>Capture/Compare 1 output polarity</p> <p>When the corresponding channel of CC1 is in output mode:</p> <p>0: OC1 active high</p> <p>1: OC1 active low</p> <p>When the corresponding channel of CC1 is in input mode:</p> <p>At this time, this bit is used to select whether IC1 or the inverse signal of IC1 is used as the trigger or capture signal.</p> <p>0: non-inverted: Capture action occurs when IC1 generates a rising edge. When used as external trigger, IC1 is non-inverted.</p> <p>1: inverted: Capture action occurs when IC1 generates a falling edge. When used as external trigger, IC1 is inverted.</p> <p><i>Note: If TIMx_BKDT.LCKCFG = 3 or 2, these bits cannot be modified.</i></p>         |
| 0         | CC1EN | <p>Capture/Compare 1 output enable</p> <p>When the corresponding channel of CC1 is in output mode:</p> <p>0: Disable - Disable output OC1 signal. The level of OC1 depends on the value of these bits TIMx_BKDT.MOEN, TIMx_BKDT.OSSI, TIMx_BKDT.OSSR, TIMx_CTRL2.OI1, TIMx_CTRL2.OI1N and TIMx_CCEN.CC1NEN.</p> <p>1: Enable - Enable output OC1 signal. The level of OC1N depends on the value of these bits TIMx_BKDT.MOEN, TIMx_BKDT.OSSI, TIMx_BKDT.OSSR, TIMx_CTRL2.OI1, TIMx_CTRL2.OI1N and TIMx_CCEN.CC1NEN.</p> <p>When the corresponding channel of CC1 is in input mode:</p> <p>At this time, this bit is used to disable/enable the capture function.</p> <p>0: Disable capture</p> <p>1: Enable capture</p> |

**Table 9-4 Output Control Bits of Complementary OCx and OCxN Channels with Break Function**

| Control Bits |      |      |       |        | Output State <sup>(1)</sup>                                |   |
|--------------|------|------|-------|--------|--|---|
| MOEN         | OSSI | OSSR | CCxEN | CCxNEN | OCx Output State   | OCxN Output State   |
| 1            | X    | 0    | 0     | 0      | Output disabled (not driven by timer)<br>OCx=0,OCx_EN=0    | Output disabled (not driven by timer)<br>OCxN=0,OCxN_EN=0     |
|              |      | 0    | 0     | 1      | Output disabled (not driven by timer)<br>OCx=0,OCx_EN=0    | OCxREF + polarity,<br>OCxN= OCxREF xor CCxNP,OCxN_EN=1        |
|              |      | 0    | 1     | 0      | OCxREF + polarity,<br>OCx= OCxREF xor CCxP,OCx_EN=1        | Output disabled (not driven by timer)<br>OCxN=0,OCxN_EN=0     |
|              |      | 0    | 1     | 1      | OCxREF + polarity + dead-time,OCx_EN=1                     | Complementary to OCxREF + polarity + dead-time,OCxN_EN=1      |
|              |      | 1    | 0     | 0      | Output disabled (not driven by timer)<br>OCx=CCxP,OCx_EN=0 | Output disabled (not driven by timer)<br>OCxN=CCxNP,OCxN_EN=0 |
|              |      | 1    | 0     | 1      | Off-state (Output enabled with inactive                    | OCxREF + polarity,  |

| Control Bits |      |      |       |        | Output State <sup>(1)</sup>                          |   |  |
|--------------|------|------|-------|--------|--|---|--|
| MOEN         | OSSI | OSSR | CCxEN | CCxNEN | OCx Output State                                     | OCxN Output State   |  |
|              |      |      |       |        | state)<br>OCx=CCxP,OCx_EN=1                          | OCxN= OCxREF xor CCxNP,OCxN_EN=1  |  |
|              |      | 1    | 1     | 0      | OCxREF + polarity,<br>OCx= OCxREF xor CCxP, OCx_EN=1 | Off-state (Output enabled with inactive state)<br>OCxN=CCxNP,OCxN_EN=1  |  |
|              |      | 1    | 1     | 1      | OCxREF + polarity + dead-time,<br>OCx_EN=1           | Complementary to OCxREF + polarity + dead-time,<br>OCxN_EN=1  |  |
| 0            |      | X    | 0     | 0      | Output disabled (not driven by timer)                |   |  |
|              |      |      | 0     | 0      | 1  | Asynchronously: OCx=CCxP, OCx_EN=0, OCxN=CCxNP,OCxN_EN=0;   |  |
|              |      |      | 0     | 1      | 0  | Then if the clock is present: OCx=OIx and OCxN=OIxN after a dead-time, when $(CCxP \wedge OIx) \wedge (CCxNP \wedge OIxN) \neq 0$ . |  |
|              |      |      | 0     | 1      | 1  |   |  |
|              |      |      | 1     | 0      | 0  | Off-state (Output enabled with inactive state)  |  |
|              |      |      | 1     | 0      | 1  | Asynchronously: OCx=CCxP, OCx_EN=1, OCxN=CCxNP,OCxN_EN=1;   |  |
|              |      |      | 1     | 1      | 0  | Then if the clock is present: OCx=OIx and OCxN=OIxN after a dead-time, when $(CCxP \wedge OIx) \wedge (CCxNP \wedge OIxN) \neq 0$   |  |
|              |      |      | 1     | 1      | 1  |   |  |

Note:

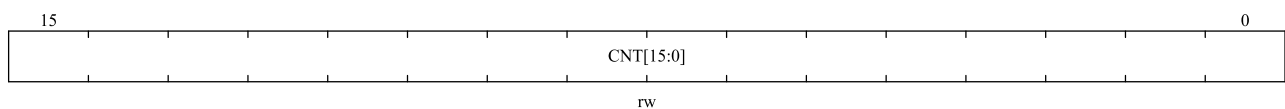
(1). If both outputs of a channel are not used (CCxEN = CCxNEN = 0), OIx, OIxN, CCxP and CCxNP must all be cleared.

Note: The status of external I/O pins connected to complementary OCx and OCxN channels depends on the OCx and OCxN channel states and GPIO and AFIO registers.

### 9.4.11 Counters (TIMx\_CNT)

Offset address: 0x24

Reset value: 0x0000

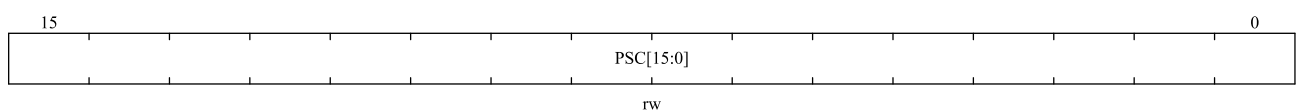


| Bit Field | Name      | Description   |
|-----------|-----------|---------------|
| 15:0      | CNT[15:0] | Counter value |

### 9.4.12 Prescaler (TIMx\_PSC)

Offset address: 0x28

Reset value: 0x0000

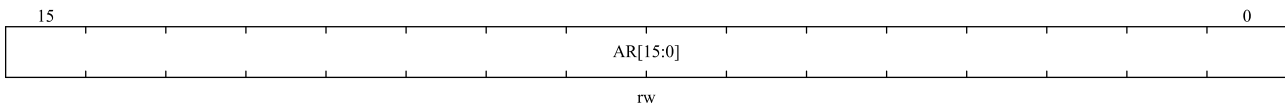


| Bit Field | Name      | Description  |
|-----------|-----------|--|
| 15:0      | PSC[15:0] | Prescaler value<br>Counter clock $f_{CK\_CNT} = f_{CK\_PSC} / (PSC [15:0] + 1)$ .<br>Each time an update event occurs, the PSC value is loaded into the active prescaler register. |

### 9.4.13 Auto-reload Register (TIMx\_AR)

Offset address: 0x2C

Reset values: 0xFFFF

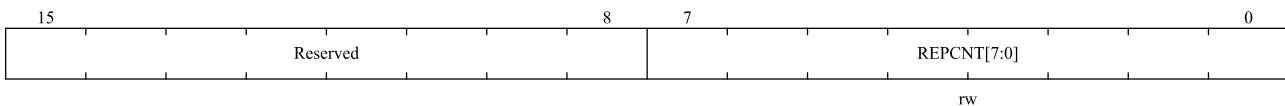


| Bit Field | Name     | Description  |
|-----------|----------|--|
| 15:0      | AR[15:0] | Auto-reload value<br>These bits define the value that will be loaded into the actual auto-reload register.<br>See Section 9.3.1 for more details.<br>When the TIMx_AR.AR [15:0] value is null, the counter does not operate. |

### 9.4.14 Repeat Count Registers (TIMx\_REPCNT)

Offset address: 0x30

Reset value: 0x0000

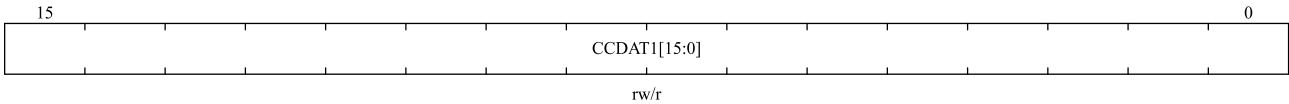


| Bit Field | Name        | Description   |
|-----------|-------------|---|
| 15:8      | Reserved    | Reserved, the reset value must be maintained  |
| 7:0       | REPCNT[7:0] | Repetition counter value<br>Repetition counter is used to generate the update event or update the timer registers only after a given number (N+1) cycles of the counter, where N is the value of TIMx_REPCNT.REPCNT .<br>The repetition counter is decremented at each counter overflow in up-counting mode, at each counter underflow in down-counting mode or at each counter overflow and at each counter underflow in center-aligned mode. Setting the TIMx_EVTGEN.UDGN bit will reload the content of TIMx_REPCNT.REPCNT and generate an update event. |

### 9.4.15 Capture/Compare Register 1 (TIMx\_CCDA1)

Offset address: 0x34

Reset value: 0x0000

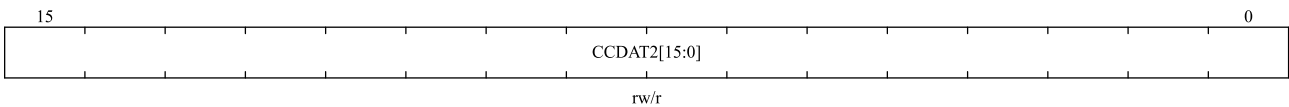


| Bit Field | Name         | Description  |
|-----------|--------------|--|
| 15:0      | CCDAT1[15:0] | <p>Capture/Compare 1 value</p> <ul style="list-style-type: none"> <li>CC1 channel is configured as output:<br/>CCDAT1 contains the value to be compared to the counter TIMx_CNT, signaling on the OC1 output.<br/>If the preload feature is not selected in TIMx_CCMOD1.OC1PEN bit, the written value is immediately transferred to the active register. Otherwise, this preloaded value is transferred to the active register only when an update event occurs.</li> <li>CC1 channel is configured as input:<br/>CCDAT1 contains the counter value transferred by the last input capture 1 event (IC1).<br/>When configured as input mode, register CCDAT1 and CCDDAT1 are only readable.<br/>When configured as output mode, register CCDAT1 and CCDDAT1 are readable and writable.</li> </ul> |

**9.4.16 Capture/Compare Register 2 (TIMx\_CCDAT2)**

Offset address: 0x38

Reset value: 0x0000

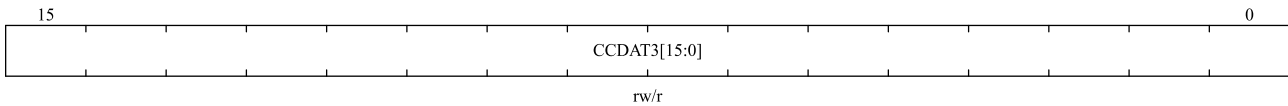


| Bit Field | Name         | Description   |
|-----------|--------------|---|
| 15:0      | CCDAT2[15:0] | <p>Capture/Compare 2 values</p> <ul style="list-style-type: none"> <li>CC2 channel is configured as output:<br/>CCDAT2 contains the value to be compared to the counter TIMx_CNT, signaling on the OC2 output.<br/>If the preload feature is not selected in TIMx_CCMOD1.OC2PEN bit, the written value is immediately transferred to the active register. Otherwise, this preloaded value is transferred to the active register only when an update event occurs.</li> <li>CC2 channel is configured as input:<br/>CCDAT2 contains the counter value transferred by the last input capture 2 event (IC2).<br/>When configured as input mode, register CCDAT2 and CCDDAT2 are only readable.<br/>When configured as output mode, register CCDAT2 and CCDDAT2 are readable and writable.</li> </ul> |

**9.4.17 Capture/Compare Register 3 (TIMx\_CCDAT3)**

Offset address: 0x3C

Reset value: 0x0000

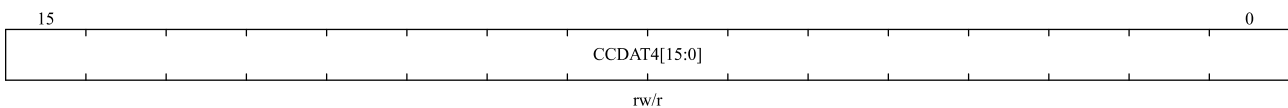


| Bit Field | Name         | Description  |
|-----------|--------------|--|
| 15:0      | CCDAT3[15:0] | <p>Capture/Compare 3 value</p> <ul style="list-style-type: none"> <li>CC3 channel is configured as output:<br/>CCDAT3 contains the value to be compared to the counter TIMx_CNT, signaling on the OC3 output.<br/>If the preload feature is not selected in TIMx_CCMOD2.OC3PEN bit, the written value is immediately transferred to the active register. Otherwise, this preloaded value is transferred to the active register only when an update event occurs.</li> <li>CC3 channel is configured as input:<br/>CCDAT3 contains the counter value transferred by the last input capture 3 event (IC3).<br/>When configured as input mode, register CCDAT3 and CCDDAT3 are only readable.<br/>When configured as output mode, register CCDAT3 and CCDDAT3 are readable and writable.</li> </ul> |

#### 9.4.18 Capture/Compare Register 4 (TIMx\_CCDAT4)

Offset address: 0x40

Reset value: 0x0000



| Bit Field | Name         | Description  |
|-----------|--------------|--|
| 15:0      | CCDAT4[15:0] | <p>Capture/Compare 4 value</p> <ul style="list-style-type: none"> <li>CC4 channel is configured as output:<br/>CCDAT4 contains the value to be compared to the counter TIMx_CNT, signaling on the OC4 output.<br/>If the preload feature is not selected in TIMx_CCMOD2.OC4PEN bit, the written value is immediately transferred to the active register. Otherwise, this preloaded value is transferred to the active register only when an update event occurs.</li> <li>CC4 channel is configured as input:<br/>CCDAT4 contains the counter value transferred by the last input capture 4 event (IC4).<br/>When configured as input mode, register CCDAT4 and CCDDAT4 are only readable.<br/>When configured as output mode, register CCDAT4 and CCDDAT4 are readable and writable.</li> </ul> |

### 9.4.19 Break and Dead-time Registers (TIMx\_BKDT)

Offset address: 0x44

Reset value: 0x0000

|      |      |     |      |      |      |             |   |           |   |   |   |   |   |   |   |
|------|------|-----|------|------|------|-------------|---|-----------|---|---|---|---|---|---|---|
| 15   | 14   | 13  | 12   | 11   | 10   | 9           | 8 | 7         | 6 | 5 | 4 | 3 | 2 | 1 | 0 |
| MOEN | AOEN | BKP | BKEN | OSSR | OSSI | LCKCFG[1:0] |   | DTGN[7:0] |   |   |   |   |   |   |   |
| rw   | rw   | rw  | rw   | rw   | rw   | rw          |   | rw        |   |   |   |   |   |   |   |

*Note: AOEN, BKP, BKEN, OSSI, OSSR, and DTGN [7:0] bits can all be write protection depending on the LOCK configuration, and it is necessary to configure all of them on the first write to the TIMx\_BKDT register.*

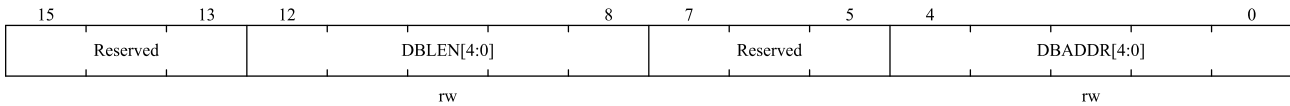
| Bit Field | Name | Description  |
|-----------|------|--|
| 15        | MOEN | <p>Main Output enable</p> <p>This bit can be set by software or hardware depending on the TIMx_BKDT.AOEN bit, and is asynchronously cleared to '0' by hardware once the brake input is active. It is only valid for channels configured as outputs.</p> <p>0: OC and OCN outputs are disabled or forced to idle state.</p> <p>1: OC and OCN outputs are enabled if TIMx_CCEN.CCxEN or TIMx_CCEN.CCxNEN bits are set. For more details, see Section 9.4.10 Capture/Compare enable registers (TIMx_CCEN).</p>  |
| 14        | AOEN | <p>Automatic output enable</p> <p>0: Only software can set TIMx_BKDT.MOEN;</p> <p>1: Software sets TIMx_BKDT.MOEN; or if the break input is not active, when the next update event occurs, hardware automatically sets TIMx_BKDT.MOEN.</p>   |
| 13        | BKP  | <p>Break input polarity</p> <p>0: Low level of the brake input is valid</p> <p>1: High level of the brake input is valid</p> <p><i>Note: Any write to this bit requires an APB clock delay to take effect.</i></p>   |
| 12        | BKEN | <p>Break enable</p> <p>0: Disable brake input (BRK and CCS clock failure events)</p> <p>1: Enable brake input (BRK and CCS clock failure events)</p> <p><i>Note: Any write to this bit requires an APB clock delay to take effect.</i></p>   |
| 11        | OSSR | <p>Off-state Selection for Run Mode</p> <p>This bit is used when TIMx_BKDT.MOEN=1 and the channel is a complementary output. The OSSR bit does not exist in timer without complementary outputs.</p> <p>0: When inactive, OCx/OCxN outputs are disabled (OCx/OCxN enable output signal = 0)</p> <p>1: When inactive, OCx/OCxN outputs are enabled with their inactive level as soon as CCxEN = 1 or CCxNEN = 1. Then, OCx/OCxN enable output signal = 1</p> <p>For more details, See Section 9.4.10, capture/compare enablement registers (TIMx_CCEN).</p> |
| 10        | OSSI | <p>Off-state Selection for Idle Mode</p> <p>This bit is used when TIMx_BKDT.MOEN=0 and the channels configured as outputs.</p> <p>0: When inactive, OCx/OCxN outputs are disabled (OCx/OCxN enable output signal = 0)</p>  |

| Bit Field | Name        | Description  |
|-----------|-------------|--|
|           |             | <p>1: When inactive, OCx/OCxN outputs are enabled with their idle level as soon as CCxEN = 1 or CCxNEN = 1. Then, OCx/OCxN enable output signal = 1</p> <p>For more details, See Section 9.4.10, capture/compare enablement registers (TIMx_CCEN).</p>   |
| 9:8       | LCKCFG[1:0] | <p>Lock Configuration</p> <p>These bits offer a write protection against software errors.</p> <p>00:</p> <ul style="list-style-type: none"> <li>– No write protected.</li> </ul> <p>01:</p> <ul style="list-style-type: none"> <li>– LOCK Level 1</li> </ul> <p>TIMx_BKDT.DTGN, TIMx_BKDT.BKEN, TIMx_BKDT.BKP, TIMx_BKDT.AOEN, TIMx_CTRL2.OIx, TIMx_CTRL2.OIxN bits enable write protection.</p> <p>10:</p> <ul style="list-style-type: none"> <li>– LOCK Level 2</li> </ul> <p>Except for register write protection in LOCK Level 1 mode, TIMx_CCEN.CCxP and TIMx_CCEN.CCxNP (If the corresponding channel is configured in output mode), TIMx_BKDT.OSSR and TIMx_BKDT.OSSI bits also enable write protection.</p> <p>11:</p> <ul style="list-style-type: none"> <li>– LOCK Level 3</li> </ul> <p>Except for register write protection in LOCK Level 2, TIMx_CCMODx.OCxMD and TIMx_CCMODx.OCxPEN bits (If the corresponding channel is configured in output mode) also enable write protection.</p> <p><i>Note: After the system reset, the LCKCFG bit can only be written once. Once written to the TIMx_BKDT register, LCKCFG will be protected until the next reset.</i></p> |
| 7:0       | DTGN [7:0]  | <p>Dead-time Generator</p> <p>These bits define the dead-time duration between inserted complementary outputs. The relationship between the DTGN value and the dead time is as follows::</p> <p>DTGN[7:5] = 0xx:</p> $\text{dead time} = \text{DTGN}[7:0] \times (t_{\text{DTS}})$ <p>DTGN[7:5] = 10x:</p> $\text{dead time} = (64 + \text{DTGN}[5:0]) \times (2 \times t_{\text{DTS}})$ <p>DTGN[7:5]=110:</p> $\text{dead time} = (32 + \text{DTGN}[4:0]) \times (8 \times t_{\text{DTS}})$ <p>DTGN [then] = 111:</p> $\text{dead time} = (32 + \text{DTGN} [4:0]) \times (16 \times t_{\text{DTS}})$ <p>t<sub>DTS</sub> value see TIMx_CTRL1.CLKD [1:0].</p>   |

#### 9.4.20 DMA Control Register (TIMx\_DCTRL)

Offset address: 0x48

Reset value: 0x0000

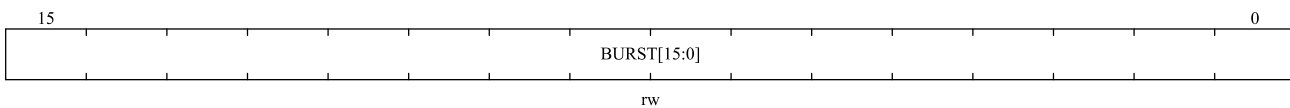


| Bit Field | Name        | Description   |
|-----------|-------------|---|
| 15:9      | Reserved    | Reserved, the reset value must be maintained, kept at 0.  |
| 12:8      | DBLEN[4:0]  | DMA Burst Length<br>This bit field defines the number DMA will accesses (write/read) TIMx_DADDR register.<br>00000: 1 time transfer<br>00001: 2 times transfers<br>00010: 3 times transfers<br>...<br>10001: 18 times transfers   |
| 7:5       | Reserved    | Reserved, the reset value must be maintained.   |
| 4:0       | DBADDR[4:0] | DMA Base Address<br>This bit field defines the first address where the DMA accesses the TIMx_DADDR register.<br>When access is done through the TIMx_DADDR first time, this bit-field specifies the address you just access. And then the second access to the TIMx_DADDR, you will access the address of "DMA Base Address + 4"<br><br>00000: TIMx_CTRL1,<br>00001: TIMx_CTRL2,<br>00010: TIMx_SMCTRL,<br>...<br>10001: TIMx_BKDT<br>10010: TIMx_DCTRL |

### 9.4.21 DMA Transfer Buffer Register (TIMx\_DADDR)

Offset address: 0x4C

Reset value: 0x0000



| Bit Field | Name        | Description  |
|-----------|-------------|--|
| 15:0      | BURST[15:0] | DMA access buffer.<br>When a read or write operation is assigned to this register, the register located at the address range (DMA base address + DMA burst length × 4) will be accessed.<br>DMA base address = The address of TIM_CTRL1 + TIMx_DCTRL.DBADDR * 4;<br>DMA burst len = TIMx_DCTRL.DBLEN + 1.<br>Example:<br>If TIMx_DCTRL.DBLEN = 0x3(4 transfers), TIMx_DCTRL.DBADDR = 0xD |

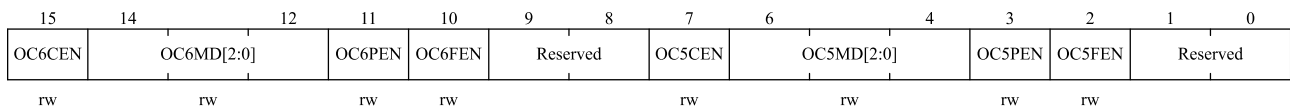


| Bit Field | Name | Description   |
|-----------|------|---|
|           |      | (TIMx_CC DAT1), DMA data length = half word, DMA memory address = buffer address in SRAM, DMA peripheral address = TIMx_DADDR address.<br>When an event occurs, TIMx will send requests to the DMA, and transfer data 4 times.<br>For the first time, DMA access to the TIMx_DADDR register will be mapped to access TIMx_CC DAT1 register;<br>For the second time, DMA access to the TIMx_DADDR register will be mapped to access TIMx_CC DAT2 register;<br>... ..<br>For the fourth time, DMA access to the TIMx_DADDR register will be mapped to access TIMx_CC DAT4 register; |

**9.4.22 Capture/Compare Mode Registers 3(TIMx\_CCMOD3)**

Offset address: 0x54

Reset value: 0x0000

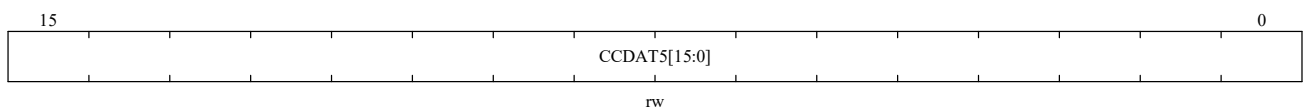


| Bit Field | Name       | Description                                  |
|-----------|------------|--|
| 15        | OC6CEN     | Output compare 6 clear enable                |
| 14:12     | OC6MD[2:0] | Output compare 6 mode                        |
| 11        | OC6PEN     | Output compare 6 preload enable              |
| 10        | OC6FEN     | Output compare 6 fast enable                 |
| 9:8       | Reserved   | Reserved, the reset value must be maintained |
| 7         | OC5CEN     | Output compare 5 clear enable                |
| 6:4       | OC5MD[2:0] | Output compare 5 mode                        |
| 3         | OC5PEN     | Output compare 5 Preload enable              |
| 2         | OC5FEN     | Output compare 5 fast enable                 |
| 1: 0      | Reserved   | Reserved, the reset value must be maintained |

**9.4.23 Capture/Compare Register 5 (TIMx\_CC DAT5)**

Offset address: 0x58

Reset value: 0x0000

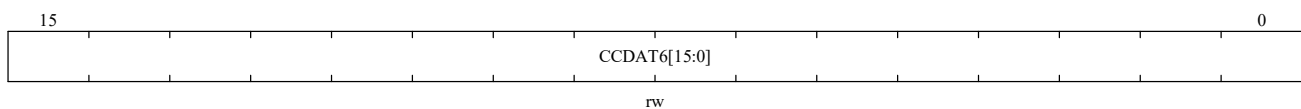


| Bit Field | Name         | Description   |
|-----------|--------------|---|
| 15:0      | CCDAT5[15:0] | <p>Capture/Compare 5 value</p> <ul style="list-style-type: none"> <li>CC5 channel can only configured as output:</li> </ul> <p>CCDAT5 contains the value to be compared to the counter TIMx_CNT, signaling on the OC5 output.</p> <p>If the preload feature is not selected in TIMx_CCMOD3.OC5PEN bit, the written value is immediately transferred to the active register. Otherwise, this preloaded value is transferred to the active register only when an update event occurs.</p> <p>TIM1_CC5 and TIM8_CC5 is used for comparator blanking.</p> |

#### 9.4.24 Capture/Compare Register 6 (TIMx\_CCDAT6)

Offset address: 0x5C

Reset value: 0x0000



| Bit Field | Name         | Description   |
|-----------|--------------|---|
| 15:0      | CCDAT6[15:0] | <p>Capture/Compare 6 value</p> <ul style="list-style-type: none"> <li>CC6 channel can only configured as output:</li> </ul> <p>CCDAT6 contains the value to be compared to the counter TIMx_CNT, signaling on the OC6 output.</p> <p>If the preload feature is not selected in TIMx_CCMOD3.OC6PEN bit, the written value is immediately transferred to the active register. Otherwise, this preloaded value is transferred to the active register only when an update event occurs.</p> <p>TIM1_CC6 for OPAMP switch.</p> |

## 10 General-purpose Timer (TIM3)

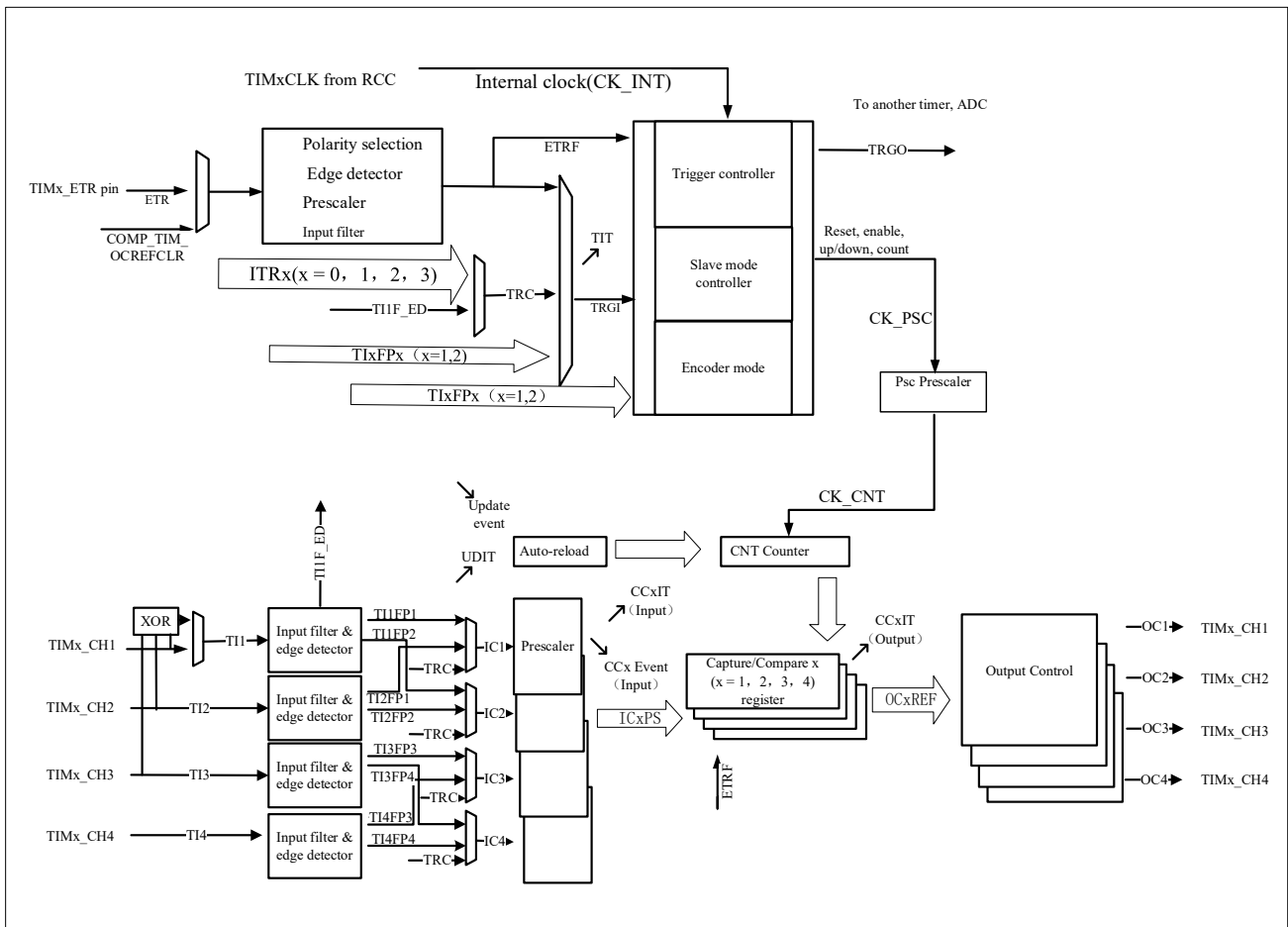
### 10.1 General-purpose Timer Introduction

The general-purpose timer (TIM3) is mainly used for counting the input signal, measuring the pulse width of the input signal and generating the output waveform, etc.

### 10.2 Main Features of General-purpose Timer

- 16-bit auto-reload counters. (It can realize up-counting, down-counting, up/down counting)
- 16-bit programmable prescaler. (The prescaler factor can be configured with any value between 1 and 65536)
- TIM3 up to 4 channels
- Channel's operating modes: PWM output, output compare, one-pulse mode output, input capture
- Timer can be controlled by external signal
- Timers can be linked together internally for timer synchronization or chaining
- The events that generate the interrupt/DMA are as follows:
  - Update event
  - Trigger event
  - Input capture
  - Output compare
- Incremental (quadrature) encoder interface: it is used for tracking motion and resolving rotation direction and position
- Hall sensor interface: it is used to do three-phase motor control

Figure 10-1 Block Diagram of TIMx (x=3)



↘ The event      ↗ Interrupt and DMA output

The capture channel 1 input can come from IOM or comparator output

### 10.3 General-purpose Timers Description

#### 10.3.1 Time-base Unit

The time-base unit mainly includes: prescaler, counter and auto-reload. When the time base unit is operating, user can read and write the corresponding registers (TIMx\_PSC, TIMx\_CNT and TIMx\_AR) at any time by the software.

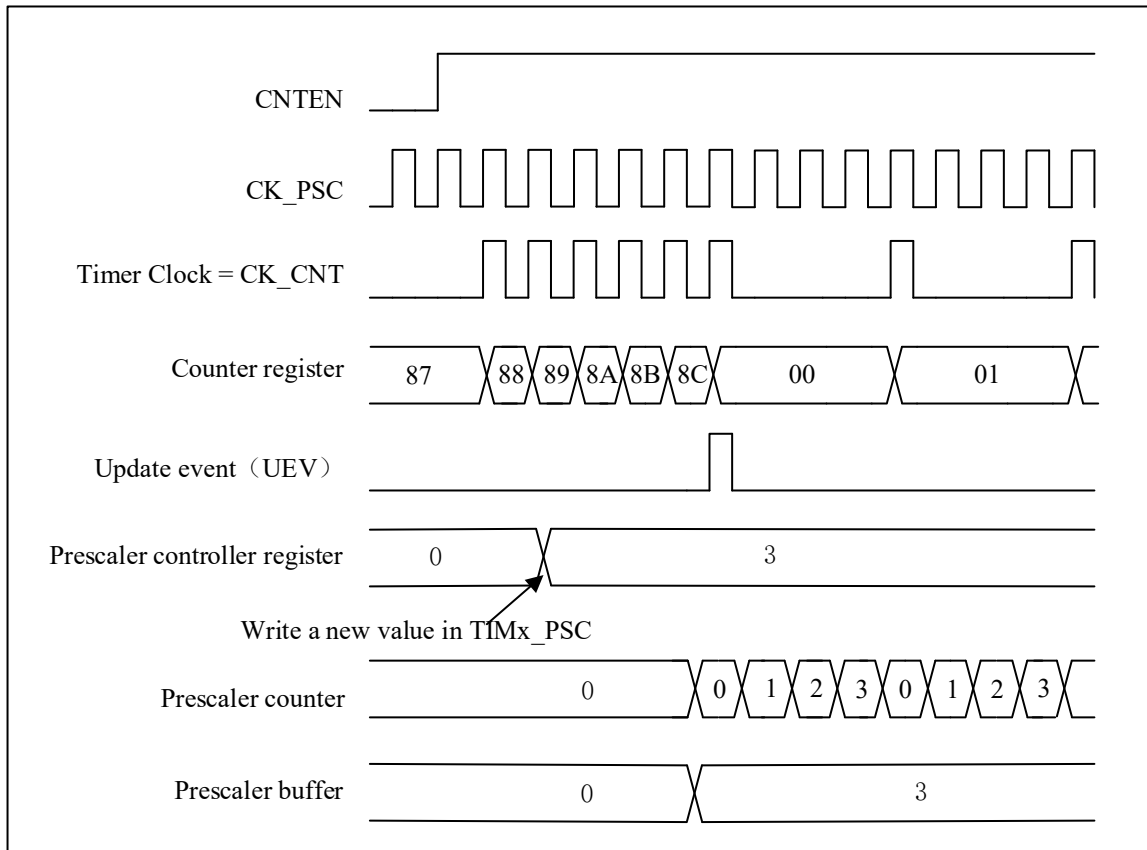
Depending on the setting of the auto-reload preload enable bit (TIMx\_CTRL1.ARPEN), the value of the preload register is transferred to the shadow register immediately or at each update event UEV. An update event is generated when the counter reaches the overflow/underflow condition and it can be generated by software when TIMx\_CTRL1.UPDIS=0. The counter CK\_CNT is valid only when the TIMx\_CTRL1.CNTEN bit is set. The counter starts counting one clock cycle after the TIMx\_CTRL1.CNTEN bit is set.

##### 10.3.1.1 Prescaler description

The TIMx\_PSC register consists of a 16-bit counter that can be used to divide the counter clock frequency by any factor

between 1 and 65536. Because this controller has a buffer, it can be dynamically changed at runtime. The new prescaler value will only be adopted during the next update event.

Figure 10-2 Counter Timing Diagram with Prescaler Division Change from 1 to 4



### 10.3.2 Counter Mode

#### 10.3.2.1 Up-counting mode

In up-counting mode, the counter will count from 0 to the value of the register TIMx\_AR, then it resets to 0. And a counter overflow event is generated.

If the TIMx\_CTRL1.UPRS bit (select update request) and the TIMx\_EVTGEN.UDGN bit are set, an update event (UEV) will generate and TIMx\_STS.UDITF will not be set by hardware, therefore, no update interrupts or update DMA requests are generated. This setting is used in scenarios where you want to clear the counter but do not want to generate an update interrupt.

Depending on the update request source is configured in TIMx\_CTRL1.UPRS, When an update event occurs, all registers are updated and the TIMx\_STS.UDITF is set:

- Update auto-reload shadow registers with preload value(TIMx\_AR), when TIMx\_CTRL1.ARPEN = 1.
- The prescaler shadow register is reloaded with the preload value(TIMx\_PSC).

To avoid updating the shadow registers when new values are written to the preload registers, you can disable the update by setting TIMx\_CTRL1.UPDIS=1.

When an update event occurs, the counter will still be cleared and the prescaler counter will also be set to 0 (but the prescaler value will remain unchanged).

The figures below show some examples of the counter behavior and the update flags for different division factors in the up-counting mode.

**Figure 10-3 Timing Diagram of Up-counting. The Internal Clock Divider Factor = 2/N**

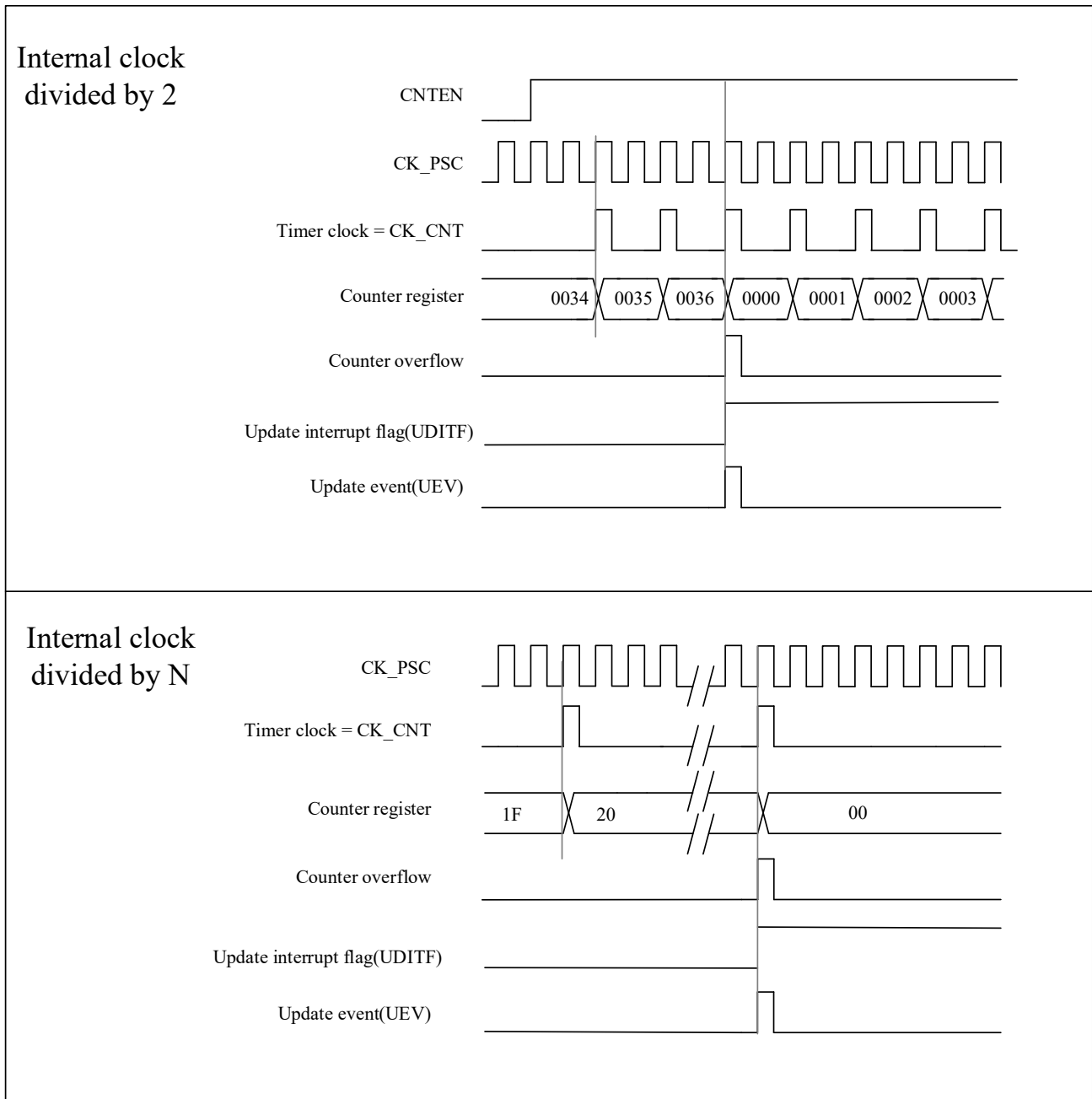
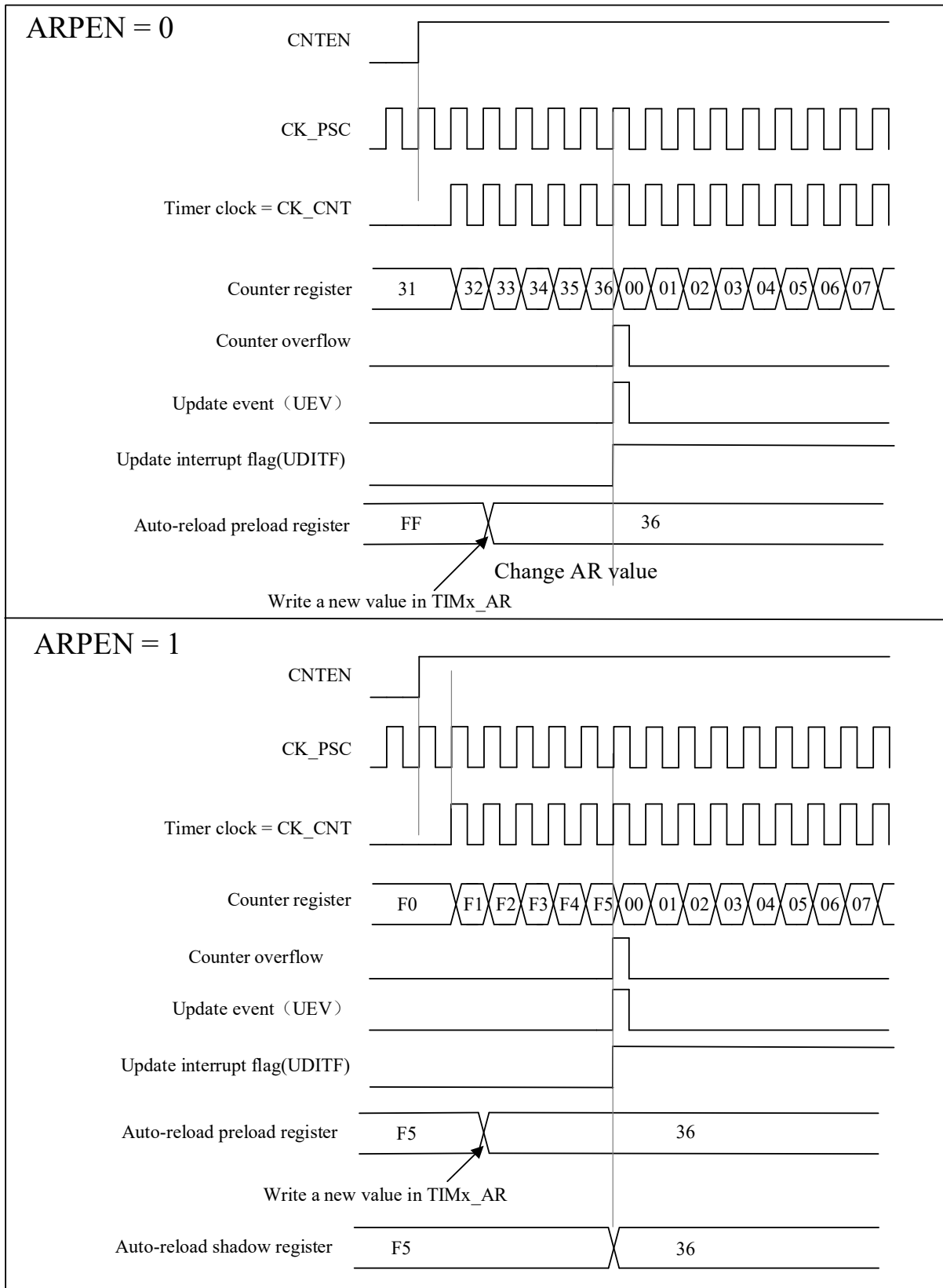


Figure 10-4 Timing Diagram of The Up-counting, Update Event When ARPEN=0/1



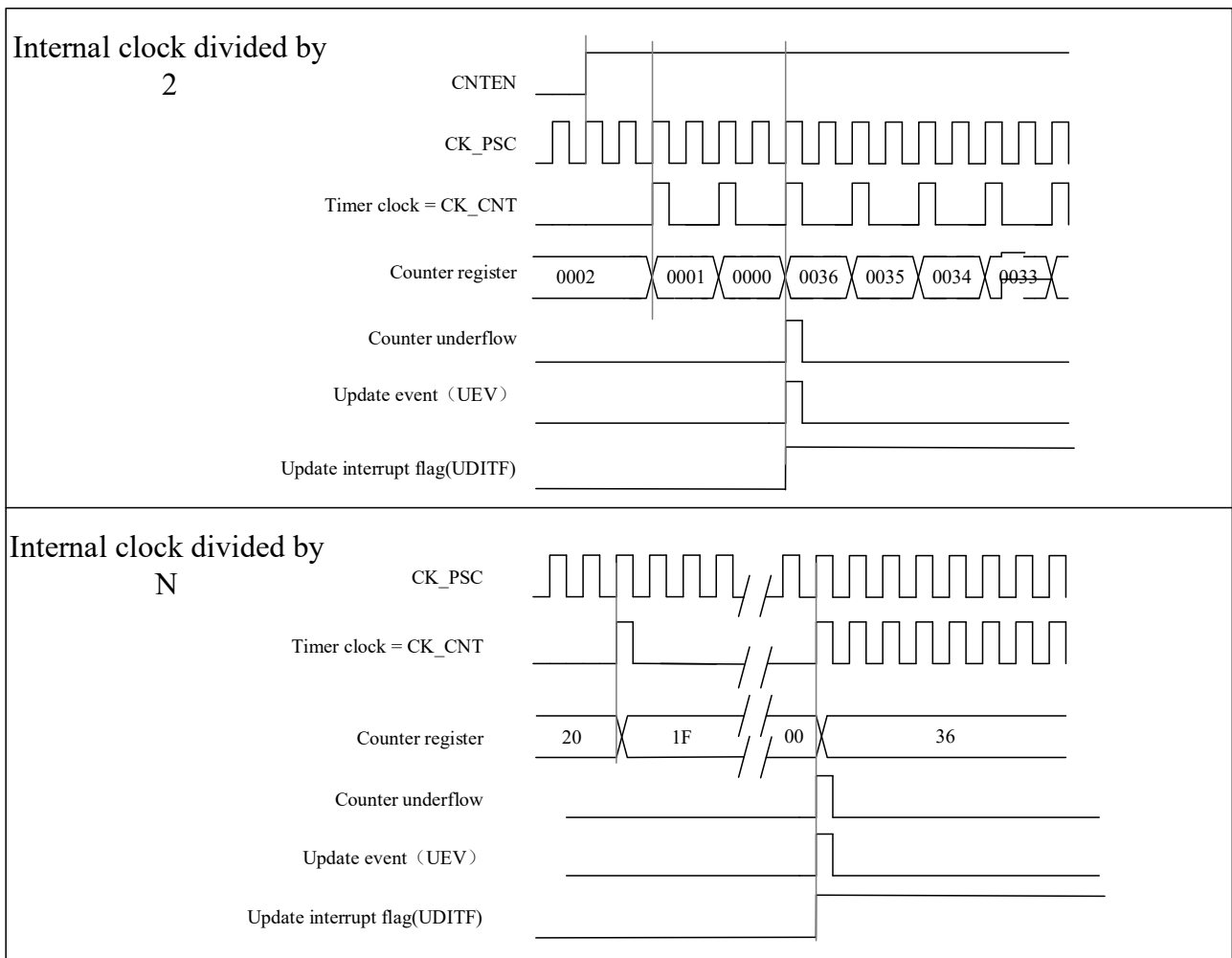
**10.3.2.2 Down-counting mode**

In down-counting mode, the counter will decrement from the value of the register TIMx\_AR to 0, then restart from the auto-reload value and generate a counter underflow event.

The process of configuring update events and updating registers in down-counting mode is the same as in up-counting mode, refer to 10.3.2.1.

The figure below shows some examples of the counter behavior and the update flags for different division factors in the down-counting mode.

**Figure 10-5 Timing Diagram of The Down-counting, Internal Clock Divided Factor = 2/N**



**10.3.2.3 Center-aligned mode**

In center-aligned mode, the counter increments from 0 to the value (TIMx\_AR) – 1, a counter overflow event is generated. It then counts down from the auto-reload value (TIMx\_AR) to 1 and generates a counter underflow event. Then the counter resets to 0 and starts counting up again.

In this mode, the TIMx\_CTRL1.DIR direction bits have no effect and the count direction is updated and specified by hardware. Center-aligned mode is valid when the TIMx\_CTRL1.CAMSEL bit is not equal to "00".



The update events can be generated each time the counter overflows and each time the counter underflows. Alternatively, an update event can also be generated by setting the TIMx\_EVTGEN. UDBG bit (either by software or using a slave mode controller). In this case, the counter restarts from 0, as does the prescaler's counter.

Please note: if the update source is a counter overflow, auto-reload update will occur before timer reload the counter.

**Figure 10-6 Timing Diagram of The Center-aligned, Internal Clock Divided Factor =2/N**

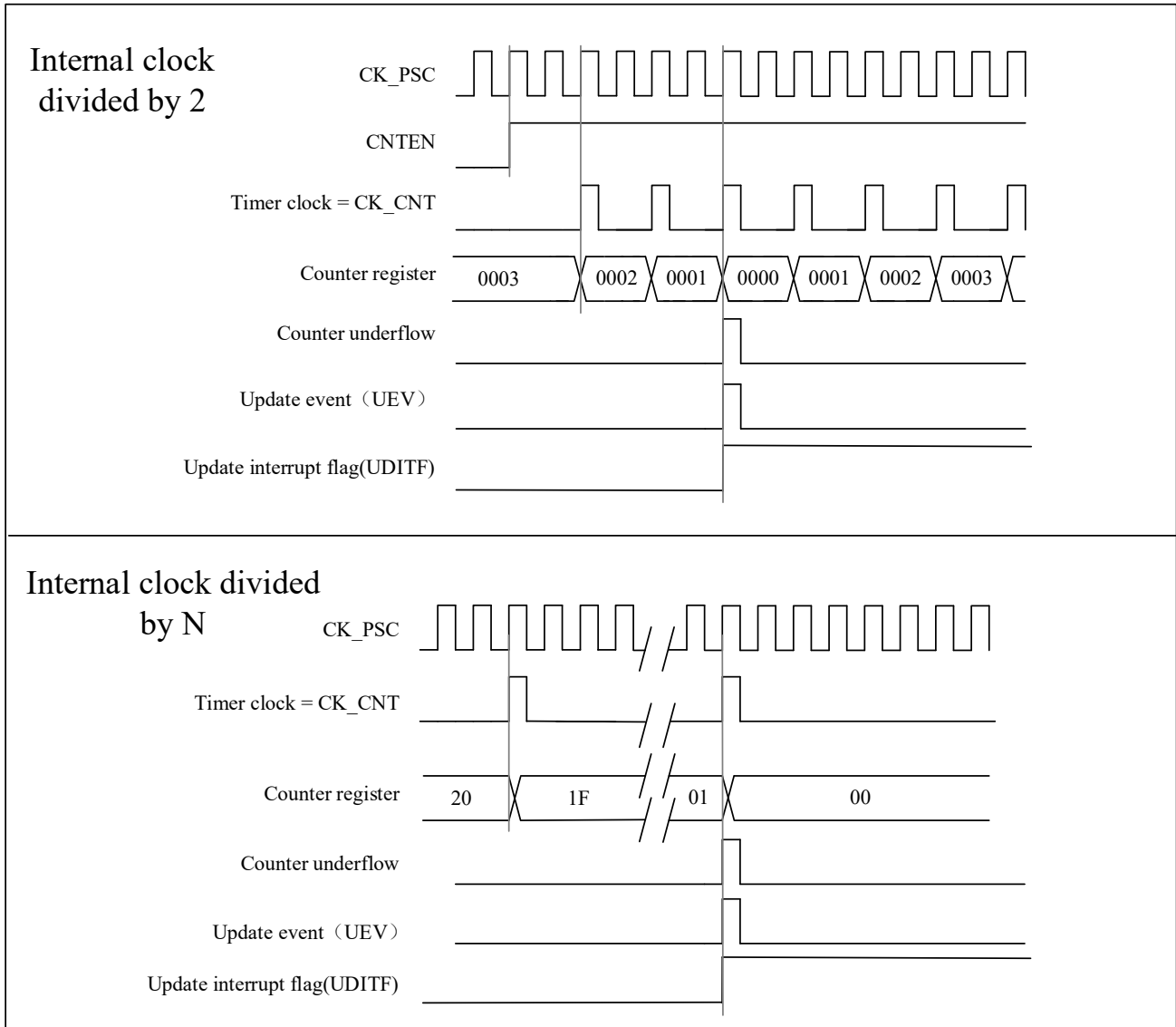
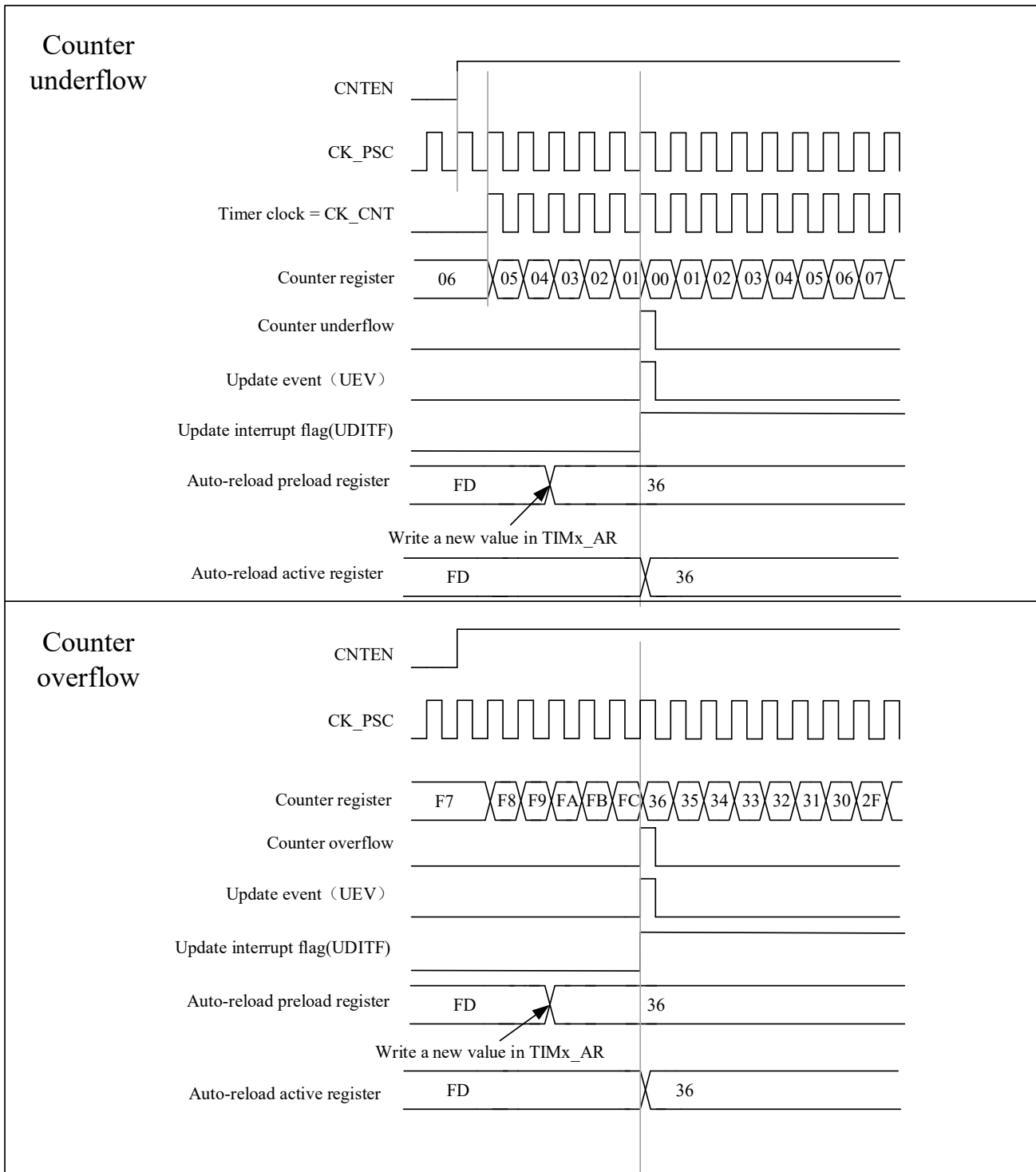


Figure 10-7 A Center-aligned Sequence Diagram That Includes Counter Overflows and Underflows (ARPEN = 1)



### 10.3.3 Clock Selection

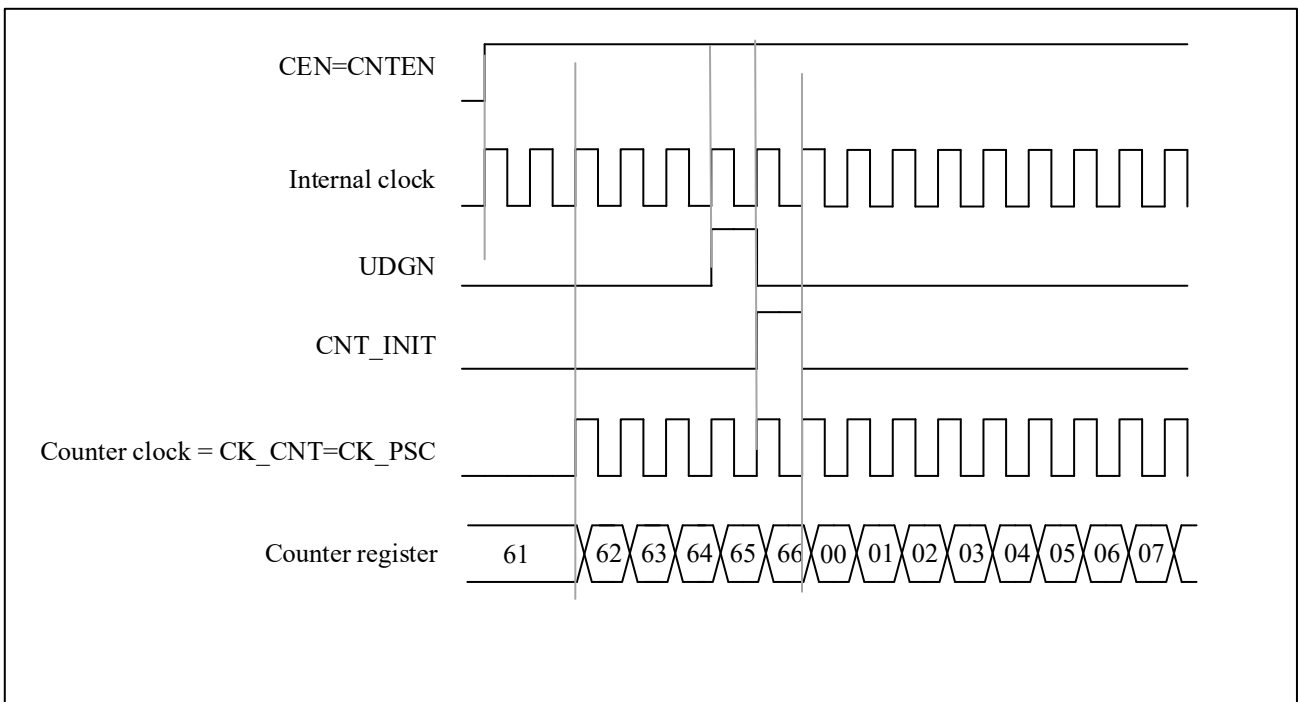
- The internal clock of timers: CK\_INT
- Two kinds of external clock mode :

- external input pin
- external trigger input ETR
- Internal trigger input (ITRx): one timer is used as a prescaler for another timer.

**10.3.3.1 Internal clock source (CK\_INT)**

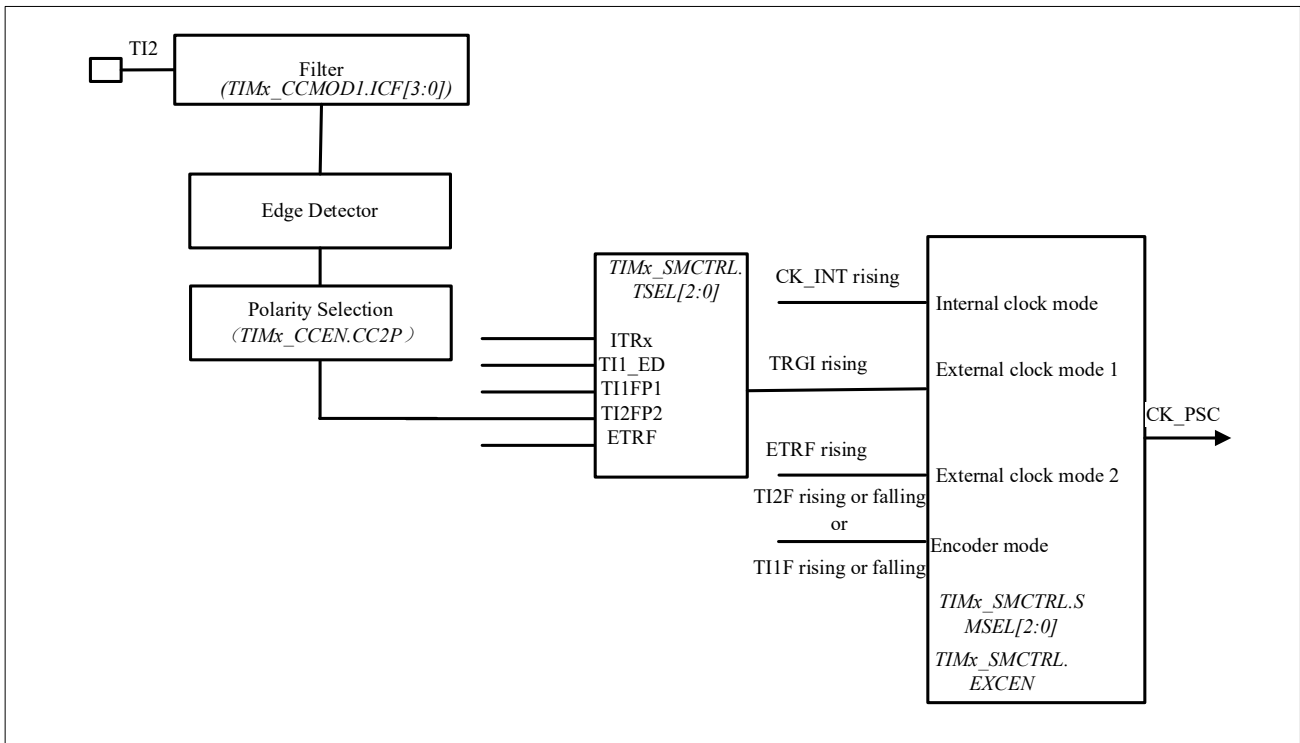
When the TIMx\_SMCTRL.SMSEL is equal to “000”, the slave mode controller is disabled. The three control bits (TIMx\_CTRL1.CNTEN, TIMx\_CTRL1. DIR, TIMx\_EVTGEN. UDN) can only be changed by software (except TIMx\_EVTGEN. UDN, which remains cleared automatically ). Assuming the TIMx\_CTRL1.CNTEN bit is written as ' 1 ' by soft, the clock source of the prescaler is provided by the internal clock CK\_INT.

**Figure 10-8 Control Circuit in Normal Mode, Internal Clock Divided by 1**



10.3.3.2 External clock source mode 1

Figure 10-9 TI2 External Clock Connection Example



This mode is selected by configuring `TIMx_SMCTRL.SMSEL=111`. The counter can be configured to count on the rising or falling edge of the clock at the selected input.

For example, to configure up-counting mode to count on the rising edge of the clock at the TI2 input, the configuration steps are as follows:

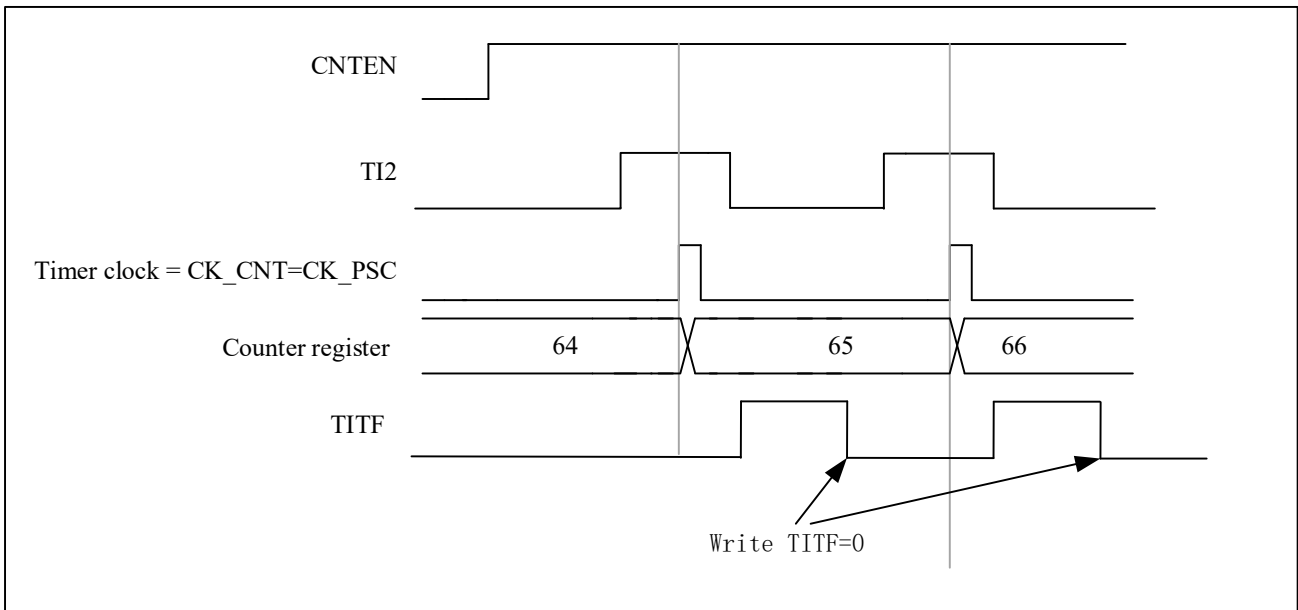
- Configure `TIMx_CCMOD1.CC2SEL` equal to '01', CC2 channel is configured as input, IC2 is mapped to TI2
- Configure `TIMx_CCEN.CC2P` equal to '0', select clock rising edge polarity
- To select input filter bandwidth by configuring `TIMx_CCMOD1.IC2F[3:0]` (if filter is not needed, keep IC2F bit at '0000')
- Configure `TIMx_SMCTRL.SMSEL` equal to '111', select timer external clock mode 1
- Configure `TIMx_SMCTRL.TSEL` equal to '110', select TI2 as the trigger input source
- Configure `TIMx_CTRL1.CNTEN` equal to '1' to start the counter

*Note: The capture prescaler is not used for triggering, so it does not need to be configured*

When the rising edge of the timer clock occurs at `TI2=1`, the counter counts once and the `TIMx_STS.TITF` flag is pulled high.

The delay between the rising edge of TI2 and the actual clock of the counter depends on the resynchronization circuit at the input of TI2.

Figure 10-10 Control Circuit in External Clock Mode 1

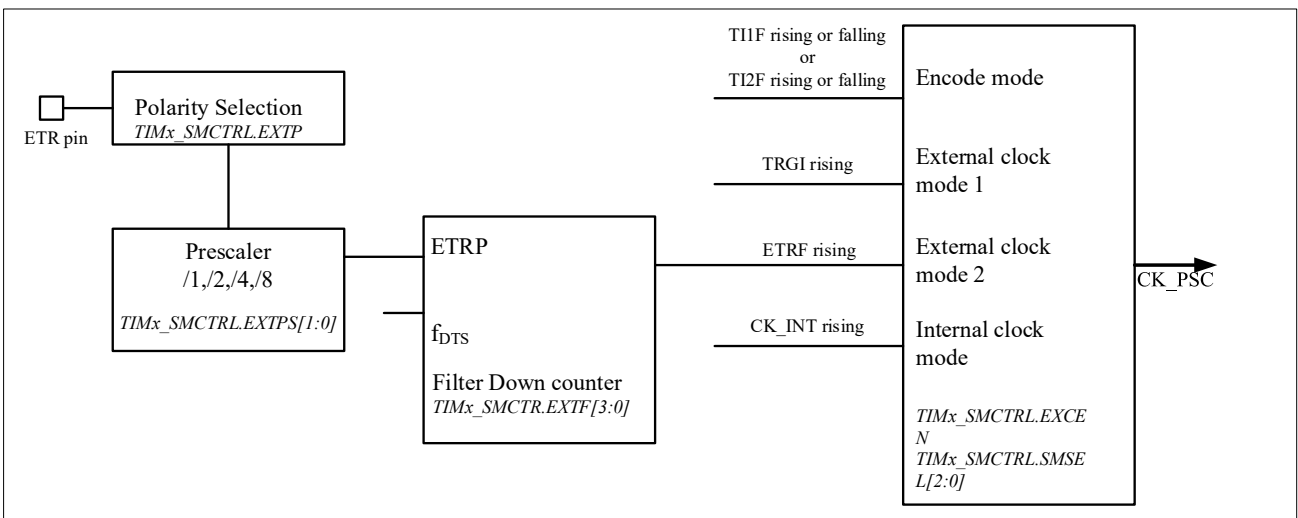


10.3.3.3 External clock source mode 2

This mode is selected by TIMx\_SMCTRL .EXCEN equal to 1. The counter can count on every rising or falling edge of the external trigger input ETR.

The following figure is a schematic diagram of the external trigger input module of the external clock source mode 2

Figure 10-11 External Trigger Input Block Diagram



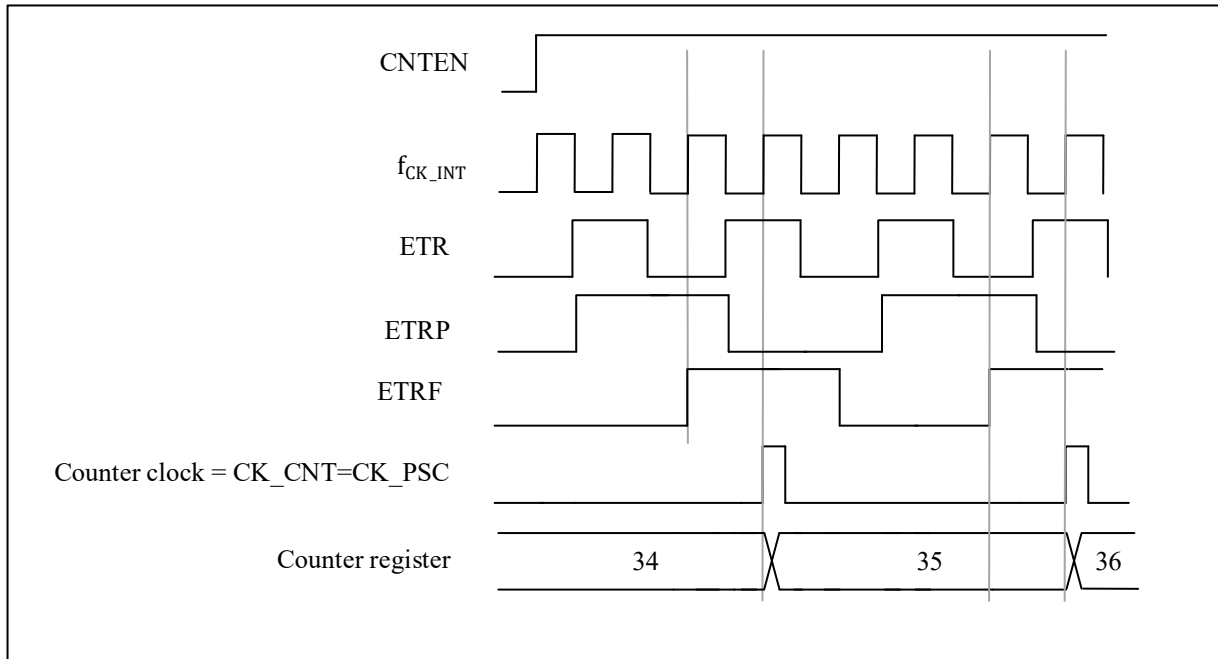
For example, use the following configuration steps to make the up counter count every 2 rising edges on ETR.

- Since no filter is required in this case, set TIMx\_SMCTRL .EXTF[3:0] equal to '0000'
- Configure the prescaler by setting TIMx\_SMCTRL.EXTPS[1:0] equal to '01'
- Select the polarity on ETR pin by setting TIMx\_SMCTRL.EXTP equal to '0', The rising edge of ETR is valid

- External clock mode 2 is selected by setting TIMx\_SMCTRL .EXCEN equal to '1'
- Turn on the counter by setting TIMx\_CTRL1. CNTEN equal to '1'

The counter counts every 2 rising edges of ETR. The delay between the rising edge of ETR and the actual clock to the counter is due to a resynchronization circuit on the ETRP signal.

**Figure 10-12 Control Circuit in External Clock Mode 2**

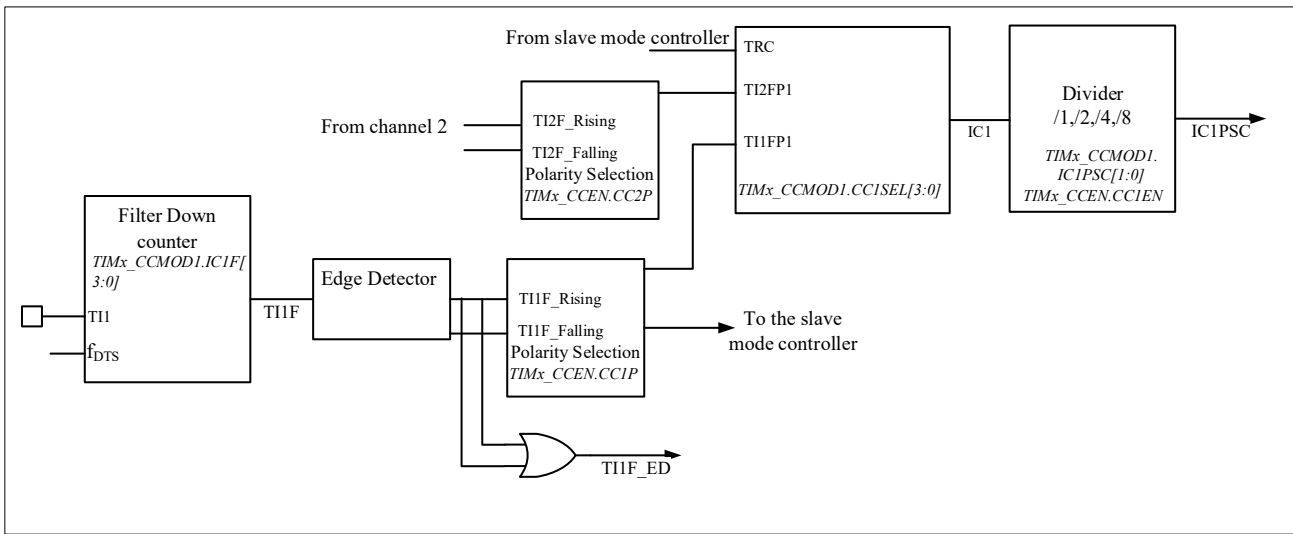


### 10.3.4 Capture/Compare Channels

Capture/compare channels include capture/compare registers and shadow registers. The input section consists of digital filters, multiplexers and prescalers. The output section includes comparators and output controls.

The input signal T<sub>Ix</sub> is sampled and filtered to generate the signal T<sub>IxF</sub>. Then, the edge detector of the polarity selection function generates signals (T<sub>IxF\_rising</sub> or T<sub>IxF\_falling</sub>), whose polarity is selected by the TIMx\_CCEN.CCxP bit. This signal can be used as a trigger input for the slave mode controller. At the same time, the signal IC<sub>x</sub> is sent to the capture register after frequency division. The following figure shows a block diagram of a capture/compare channel.

Figure 10-13 Capture/Compare Channel (Example: Channel 1 Input Stage)



The output part generates an intermediate waveform OCxRef ( high level active) as reference. The polarity acts at the end of the chain.

Figure 10-14 Capture/Compare Channel 1 Main Circuit

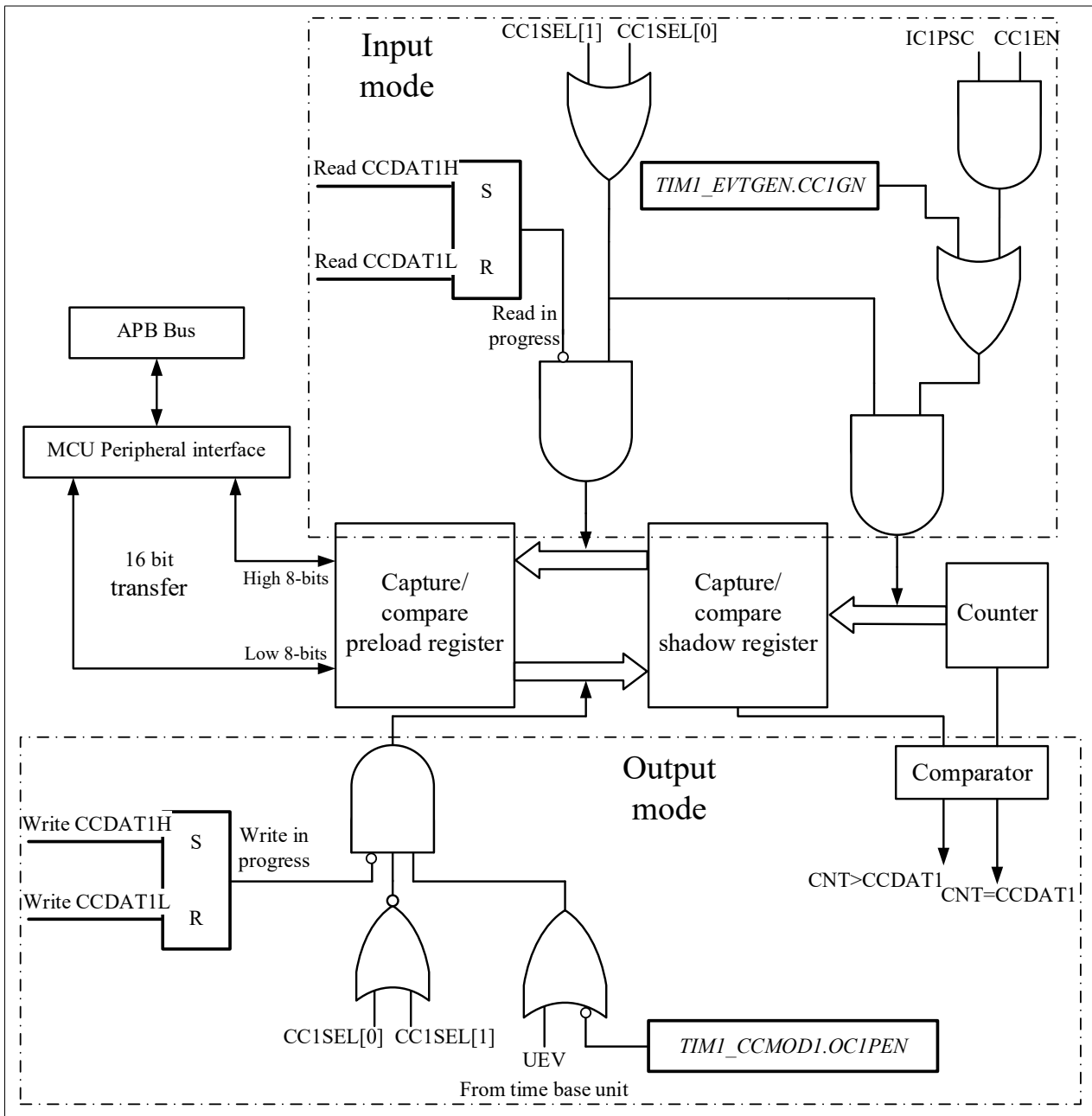
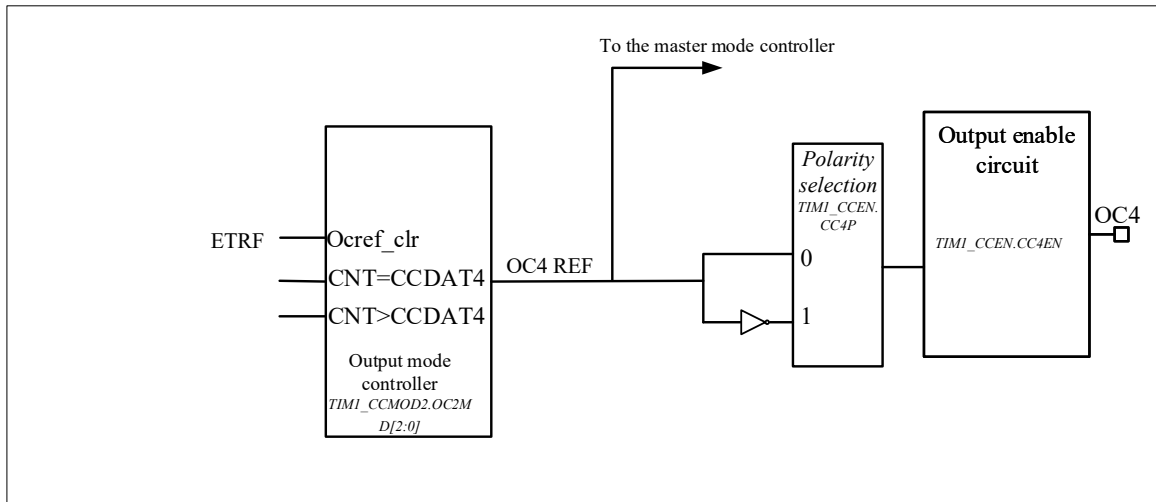




Figure 10-15 Output Part of Channel (x = 1,2,3,4, Using Channel 4 as An Example)



Reads and writes always access preloaded registers when capturing/comparing. The two specific operating processes are as follows:

In capture mode, the capture is actually done in the shadow register, and then the value in the shadow register is copied into the preload register.

In compare mode, as opposed to capture mode, the value of the preload register is copied into the shadow register, which is compared with the counter.

### 10.3.5 Input Capture Mode

In capture mode, the TIMx\_CCDA Tx registers are used to latch the counter value after the ICx signal detects.

There is a capture interrupt flag TIMx\_STS.CCxITF, which can trigger an interrupt or DMA request if the corresponding interrupt enable is pulled high.

The TIMx\_STS.CCxITF bit is set by hardware when a capture event occurs and is cleared by software or by reading the TIMx\_CCDA Tx register.

The overcapture flag TIMx\_STS.CCxOCF is set equal to 1 when the counter value is captured in the TIMx\_CCDA Tx register and TIMx\_STS.CCxITF is already pulled high. Unlike the former, TIMx\_STS.CCxOCF is cleared by writing 0.

To capture the counter value on the rising edge of the TI1 input into the TIMx\_CCDA T1 register, the configuration flow is as follows:

- To select a valid input:

Configure TIMx\_CCMOD1.CC1SEL to '01'. At this time, the input is the CC1 channel, and IC1 is mapped to TI1.

- The duration of the input filter required for programming:

Set the sampling frequency of the TI1 input and the length of the digital filter by configuring the TIMx\_CCMODx.ICxF bits. Example: if the input signal has jitter of up to 5 internal clock cycles, we must choose a filter duration longer than these 5 clock cycles. When 8 consecutive samples (sampled at f<sub>DTS</sub> frequency) with the new level are detected, we can validate the transition on TI1. Then configure TIMx\_CCMOD1.IC1F to '0011'.

- By configuring `TIMx_CCEN.CC1P=0`, select the rising edge as the valid transition polarity on the TI1 channel.
- Configure the input prescaler. In this example, configure `TIMx_CCMOD1.IC1PSC= '00'` to disable the prescaler because we want to capture every valid transition.
- Enable capture by configuring `TIMx_CCEN.CC1EN = '1'`.

If you want to enable DMA request, you can configure `TIMx_DINTEN.CC1DEN=1`. If you want to enable related interrupt request, you can configure `TIMx_DINTEN.CC1IEN` bit=1

### 10.3.6 PWM Input Mode

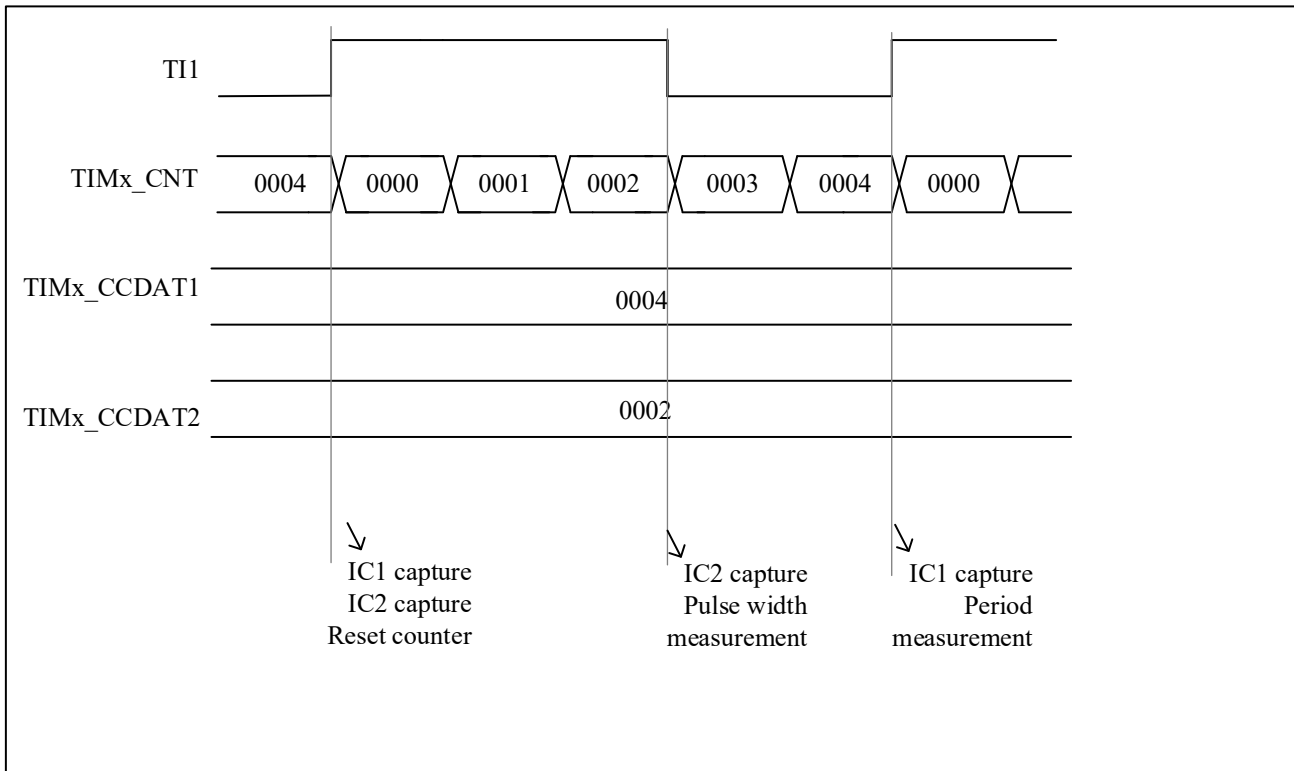
There are some differences between PWM input mode and normal input capture mode, including:

- Two ICx signals are mapped to the same TIx input.
- The two ICx signals are active on edges of opposite polarity.
- Select one of two TIxFP signals as trigger input.
- The slave mode controller is configured in reset mode.

For example, the following configuration flow can be used to get the period and duty cycle of the PWM signal on TI1 (It depends on the frequency of `CK_INT` and the value of the prescaler).

- Configure `TIMx_CCMOD1.CC1SEL` equal to '01' to select TI1 as valid input for `TIMx_CCDAT1`.
- Configure `TIMx_CCEN.CC1P` equal to '0' to select the active polarity of filtered timer input 1 (TI1FP1), valid on the rising edge.
- Configure `TIMx_CCMOD1.CC2SEL` equal to '10' select TI1 as valid input for `TIMx_CCDAT2`.
- Configure `TIMx_CCEN.CC2P` equal to 1 to select the valid polarity of filtered timer input 2 (TI1FP2), valid on the falling edge.
- Configure `TIMx_SMCTRL.TSEL=101` to select Filtered timer input 1 (TI1FP1) as valid trigger input.
- Configure `TIMx_SMCTRL.SMSEL=100` to configure the slave mode controller to reset mode.
- Configure `TIMx_CCEN.CC1EN=1` and `TIMx_CCEN.CC2EN=1` to enable capture.

Figure 10-16 PWM Input Mode Timing



Because of only filter timer input 1 (TI1FP1) and filter timer input 2 (TI2FP2) are connected to the slave mode controller, the PWM input mode can only be used with the TIMx\_CH1/TIMx\_CH2 signals.

### 10.3.7 Forced Output Mode

User can force output compare signals to active or inactive level directly, in output mode (TIMx\_CCMODx.CCxSEL=00) by software.

User can set TIMx\_CCMODx.OCxMD=101 to force the output compare signal to active level. And the OCxREF will be forced high, OCx get opposite value to CCxP polarity bit. On the other hand, user can set TIMx\_CCMODx.OCxMD=100 to force the output compare signal to inactive level.

The values of the TIMx\_CCDATx shadow register and the counter still comparing with each other in this mode. And the flag still can be set. Therefore, the interrupt and DMA requests still can be sent.

The comparison between the output compare register TIMx\_CCDATx and the counter TIMx\_CNT has no effect on OCxREF. And the flag still can be set. Therefore, the interrupt and DMA requests still can be sent.

### 10.3.8 Output Compare Mode

User can use this mode to control the output waveform, or to indicate that a period of time has elapsed.

When the capture/compare register and the counter have the same value, the output compare function's operations are as follow:

- TIMx\_CCMODx.OCxMD is for output compare mode, and TIMx\_CCEN.CCxP is for output polarity. When the compare matches, if set TIMx\_CCMODx.OCxMD=000, the output pin will keep its level; if set

TIMx\_CCMODx.OCxMD=001, the output pin will be set active; if set TIMx\_CCMODx.OCxMD=010, the output pin will be set inactive; if set TIMx\_CCMODx.OCxMD=011, the output pin will be set to toggle.

- Set TIMx\_STS.CCxITF.
- If user set TIMx\_DINTEN.CCxIEN, a corresponding interrupt will be generated.
- If user set TIMx\_DINTEN.CCxDEN and set TIMx\_CTRL2.CCDSEL to select DMA request, and DMA request will be sent.

User can set TIMx\_CCMODx.OCxPEN to choose capture/compare shadow register using capture/compare preload registers(TIMx\_CCDA Tx) or not.

The time resolution is one count of the counter.

In one pulse mode, the output compare mode can also be used to output a single pulse.

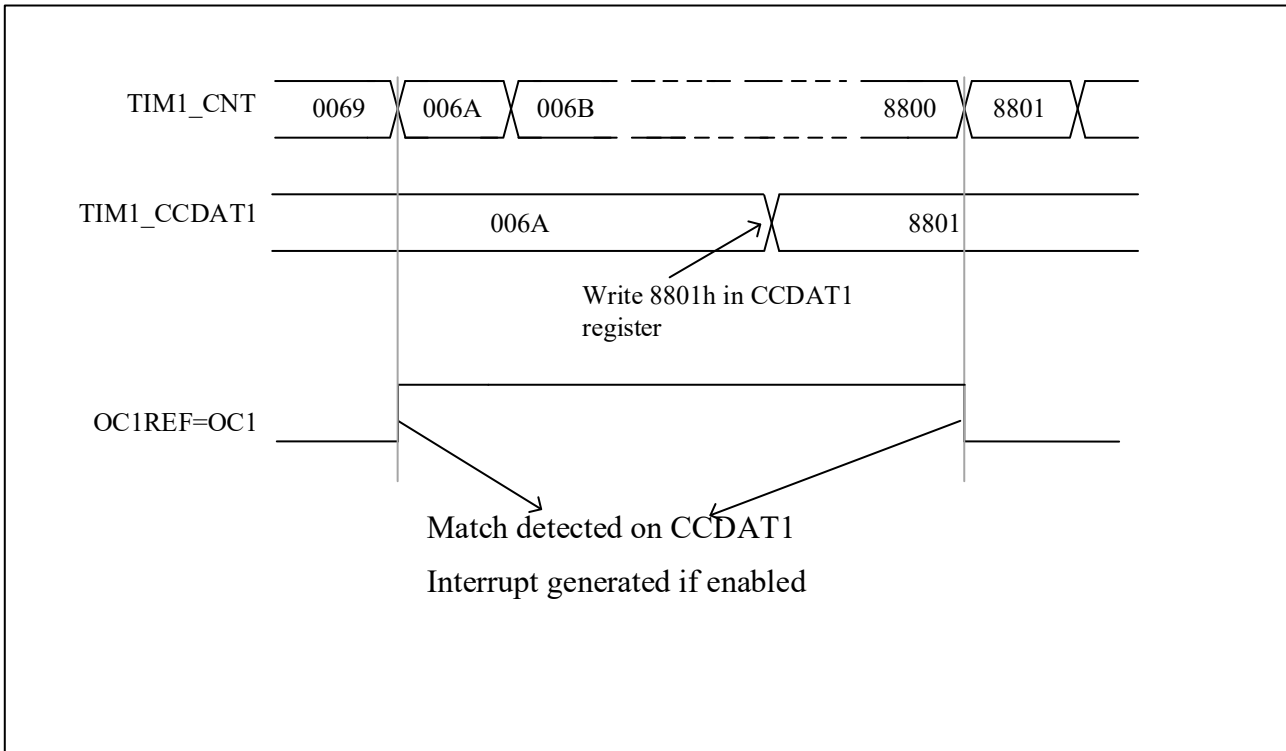
Here are the configuration steps for output compare mode:

- First of all, user should select the counter clock.
- Secondly, set TIMx\_AR and TIMx\_CCDA Tx with desired data.
- If user need to generate an interrupt, set TIMx\_DINTEN.CCxIEN.
- Then select the output mode by set TIMx\_CCEN.CCxP, TIMx\_CCMODx.OCxMD, TIMx\_CCEN.CCxEN, etc.
- At last, set TIMx\_CTRL1.CNTEN to enable the counter.

User can update the output waveform by setting TIMx\_CCDA Tx at any time, as long as the preload register is not enabled. Otherwise the TIMx\_CCDA Tx shadow register will be updated at the next update event.

Here is an example.

Figure 10-17 Output Compare Mode, Toggle on OC1



### 10.3.9 PWM Mode

User can get a signal whose duty cycle is determined by the value of the TIMx\_CCDATx register and whose frequency is determined by the value of the TIMx\_AR register in PWM mode. And depends on the value of TIMx\_CTRL1.CAMSEL, the TIM can generate PWM signal in edge-aligned mode or center-aligned mode.

User can set PWM mode 1 or PWM mode 2 by setting TIMx\_CCMODx. OCxMD=110 or setting TIMx\_CCMODx. OCxMD=111. To enable preload register, user must set corresponding TIMx\_CCMODx.OCxPEN. And then set TIMx\_CTRL1.ARPEN to auto-reload preload register eventually.

User can set polarity of OCx by setting TIMx\_CCEN.CCxP. To enable the output of OCx, user need to set the combination of the value of CCxEN.

The values of TIMx\_CNT and TIMx\_CCDATx are always compared with each other when the TIM is under PWM mode.

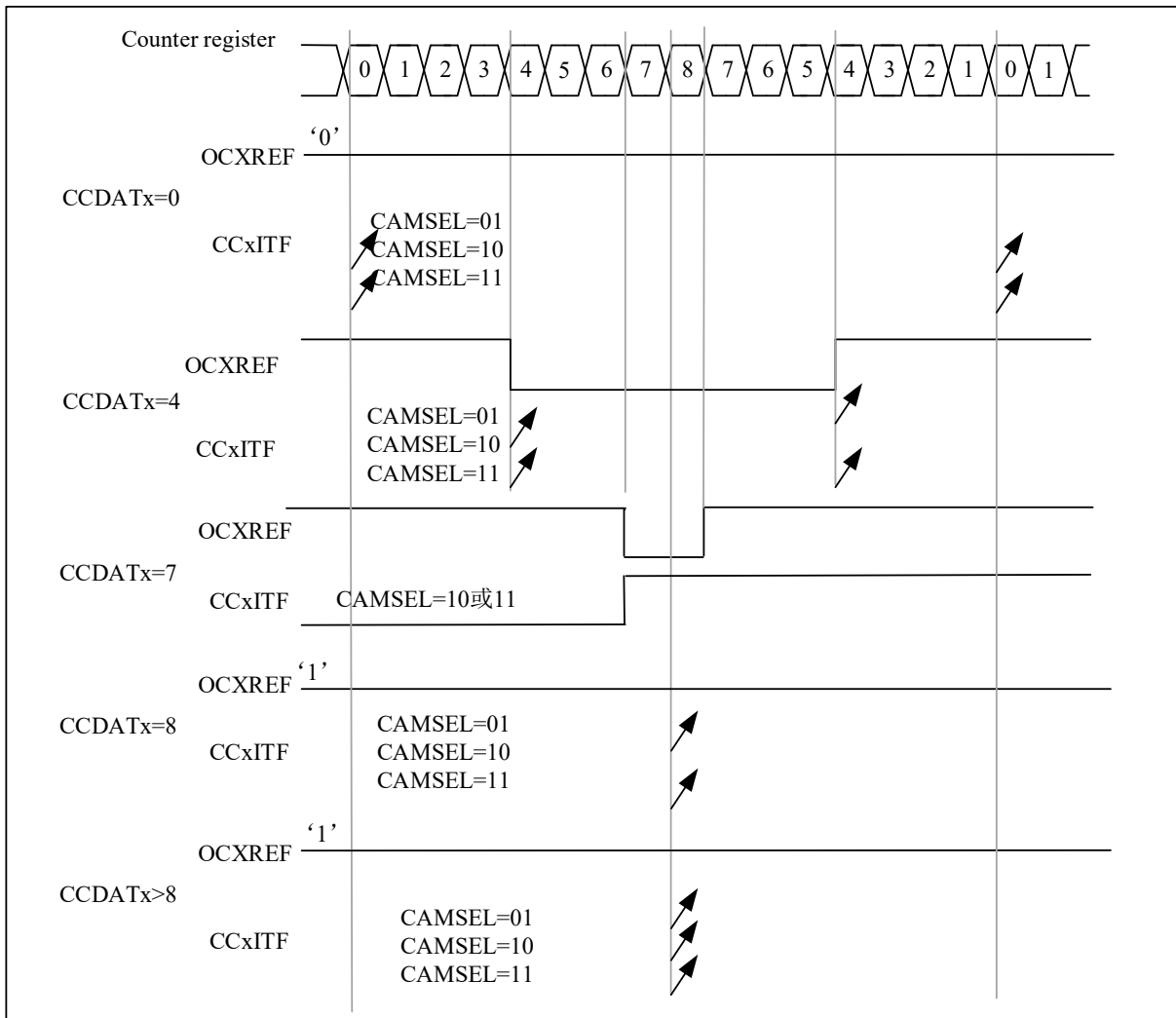
Only if an update event occurs, the preload register will transfer to the shadow register. Therefore user must reset all the registers by setting TIMx\_EVTGEN.UDGN before the counter starts counting.

#### 10.3.9.1 PWM center-aligned mode

If user set TIMx\_CTRL1.CAMSEL equal 01, 10 or 11, the PWM center-aligned mode will be active. The setting of the compare flag depends on the value of TIMx\_CTRL1.CAMSEL. There are three kinds of situation that the compare flag is set, only when the counter counts up, only when the counter counts down, or when the counter counts up and counts down. User should not modified TIMx\_CTRL1.DIR by software, it is updated by hardware.

Examples of center-aligned PWM waveforms is as follow, and the setting of the waveform are: TIMx\_AR=8, PWM mode 1, the compare flag is set when the counter counts down corresponding to TIMx\_CTRL1. CAMSEL=01.

Figure 10-18 Center-aligned PWM Waveform (AR=8)



When using center-aligned mode, users should pay attention to the following considerations:

- It depends on the value of TIMx\_CTRL1.DIR that the counter counts up or down. Caution that the DIR and CAMSEL bits should not be changed at the same time.
- User should not write the counter while running in center-aligned mode, otherwise it will cause unexpected results. Here are some examples:
  - If the value written into the counter is 0 or is the value of TIMx\_AR, the direction will be updated but the update event will not be generated.
  - If the value written into the counter is greater than the value of auto-reload, the direction will not be updated.
- To be on the safe side, user is suggested setting TIMx\_EVTGEN.UDGN to generate an update by software before starting the counter, and not writing the counter while it is running.

### 10.3.9.2 PWM edge-aligned mode

There are two kinds of configuration in edge-aligned mode, up-counting and down-counting.

- **Up-counting**

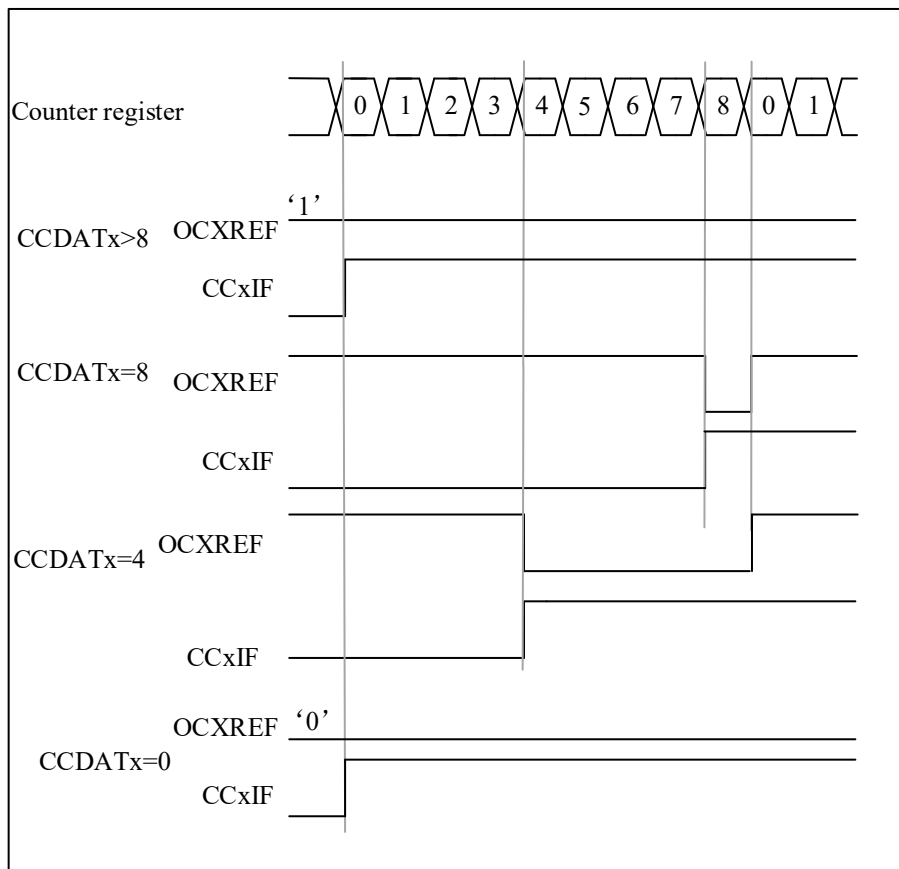
User can set TIMx\_CTRL1.DIR=0 to make counter counts up.

Example for PWM model.

When TIMx\_CNT < TIMx\_CCxDATx, the PWM signal OCxREF is high level, otherwise it will be low level. If the compare value in TIMx\_CCxDATx is greater than the auto-reload value, the OCxREF will remains 1. Conversely, if the compare value is 0, the OCxREF will remains 0.

When TIMx\_AR=8, the PWM waveforms are as follow.

**Figure 10-19 Edge-aligned PWM Waveform (APR=8)**



- **Down-counting**

User can set TIMx\_CTRL1.DIR=1 to make counter counts down.

Example for PWM model.

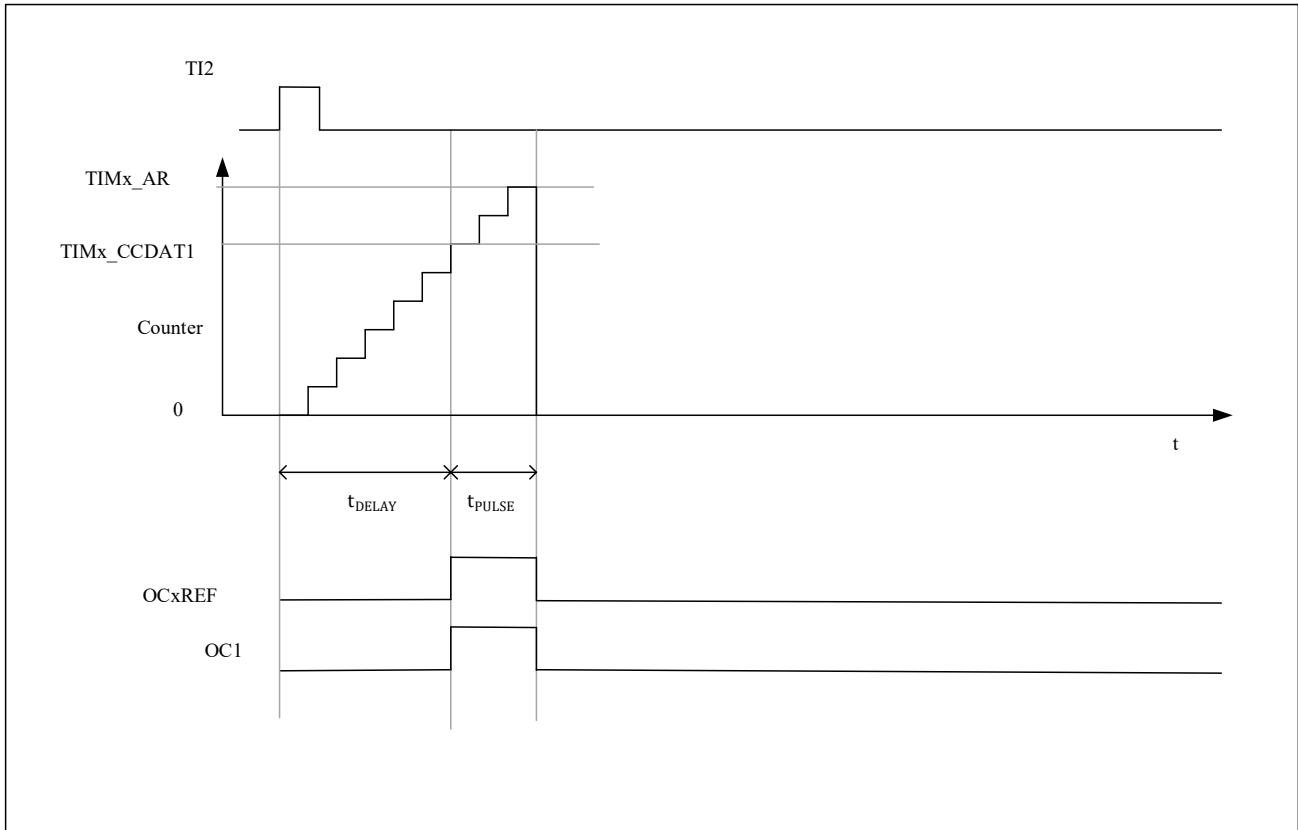
When TIMx\_CNT > TIMx\_CCxDATx, the OCxREF is low level, otherwise it will be high level. If the compare value in TIMx\_CCxDATx is greater than the auto-reload value, the OCxREF will remains 1.

*Note: If the nth PWM cycle CCDATx shadow register >= AR value, the shadow register value of CCDATx in the (n+1)th PWM cycle is 0. At the moment when the counter is 0 in the (n+1)th PWM cycle, although the value of the counter = CCDATx shadow register = 0 and OCxREF = '0', no compare event will be generated.*

### 10.3.10 One-pulse Mode

In the one-pulse mode (ONEPM), a trigger signal is received, and a pulse  $t_{PULSE}$  with a controllable pulse width is generated after a controllable delay  $t_{DELAY}$ . The output mode needs to be configured as output compare mode or PWM mode. After selecting one-pulse mode, the counter will stop counting after the update event UEV is generated.

Figure 10-20 Example of One-pulse Mode



The following is an example of a one-pulse mode:

A rising edge trigger is detected from the TI2 input, and a pulse with a width of  $t_{PULSE}$  is generated on OC1 after a delay of  $t_{DELAY}$ .

1. Counter configuration: count up, counter  $TIMx\_CNT < TIMx\_CCDAT1 \leq TIMx\_AR$ ;
2. TI2FP2 is mapped to TI2,  $TIMx\_CCMOD1.CC2SEL = '01'$ ; TI2FP2 is configured for rising edge detection,  $TIMx\_CCEN.CC2P = '0'$ ;
3. TI2FP2 acts as the trigger (TRGI) of the slave mode controller and starts the counter,  $TIMx\_SMCTRL.TSEL = '110'$ ,  $TIMx\_SMCTRL.SMSEL = '110'$  (trigger mode);
4.  $TIMx\_CCDAT1$  writes the count value to be delayed ( $t_{DELAY}$ ),  $TIMx\_AR - TIMx\_CCDAT1$  is the count value of the pulse width  $t_{PULSE}$ ;
5. Configure  $TIMx\_CTRL1.ONEPM = 1$  to enable single pulse mode, configure  $TIMx\_CCMOD1.OC1MD = '111'$  to select PWM2 mode;



6. Wait for an external trigger event on TI2, and a one pulse waveform will be output on OC1;

**10.3.10.1 Special case: OCx fast enable:**

In one-pulse mode, an edge is detected through the TIX input, and triggers the start of the counter to count to the comparison value and then output a pulse. These operations limit the minimum delay  $t_{DELAY}$ .

You can set `TIMx_CCMODx.OCxFEN=1` to turn on OCx fast enable, after triggering the rising edge, the OCxREF signal will be forced to be converted to the same level as the comparison match occurs immediately, regardless of the comparison result. OCxFEN fast enable only takes effect when the channel mode is configured as PWM1 and PWM2 modes.

**10.3.11 Clearing The Ocxref Signal on An External Event**

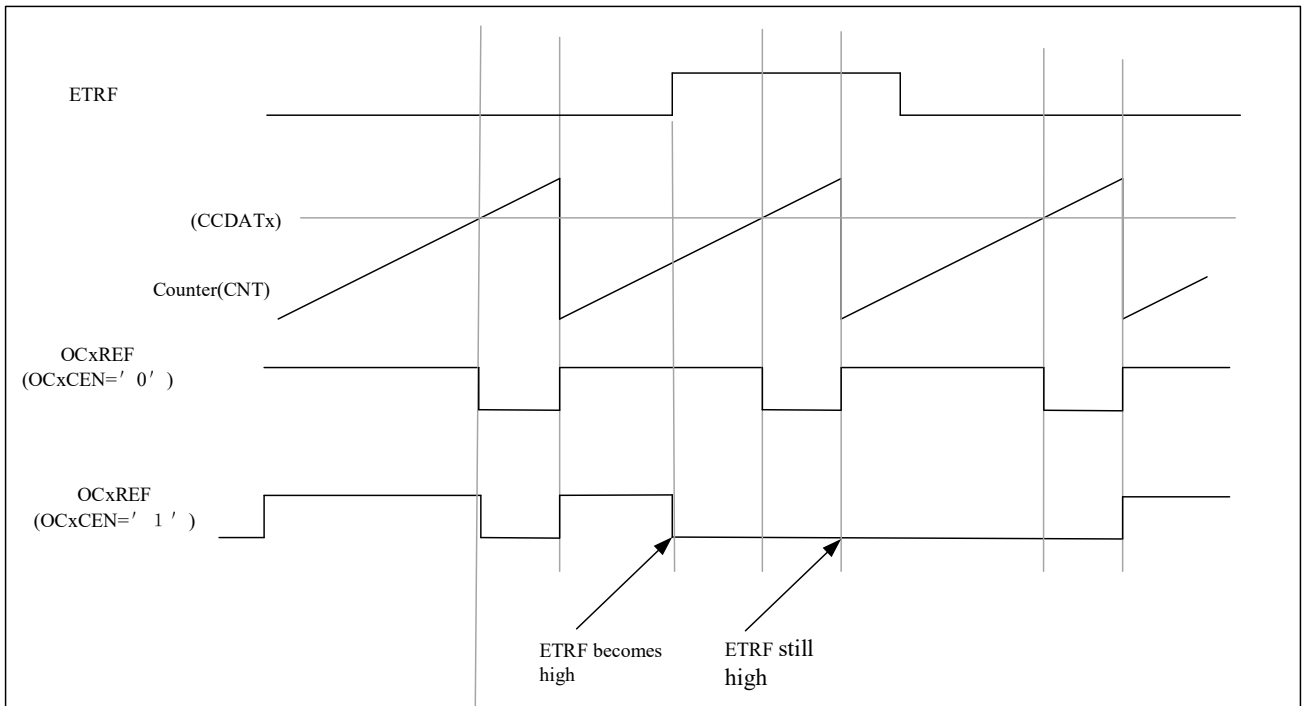
If user set `TIMx_CCMODx.OCxCEN=1`, high level of ETRF input can be used to driven the OCxREF signal to low, and the OCxREF signal will remains low, until the next UEV happens. Only in output compare mode and PWM modes this function can be used. This cannot be used when it is in forced mode.

Here is an example for it. To control the current, user can connect the ETR signal to the output of a comparator, and the operation for ETR should be as follow:

- Set `TIMx_SMCTRL.EXTPS=00` to disable the external trigger prescaler.
- Set `TIMx_SMCTRL.EXCEN=0` to disable the external clock mode 2.
- Set `TIMx_SMCTRL.EXTP` and `TIMx_SMCTRL.EXTF` to configure the external trigger polarity and external trigger filter according to the need.

Here is an example for the case that when ETRF input becomes high, the behavior of OCxREF signal for different value of OCxCEN. Timer is set to be in PWM mode in this case.

**Figure 10-21 Control Circuit in Reset Mode**



### 10.3.12 Debug Mode

When the microcontroller is in debug mode (the Cortex<sup>®</sup>-M0 core halted), depending on the DBG\_CTRL.TIMx\_STOP configuration in the PWR module, the TIMx counter can either continue to operate normally or stop. For more details, refer to 3.3.2.

### 10.3.13 TIMx and External Trigger Synchronization

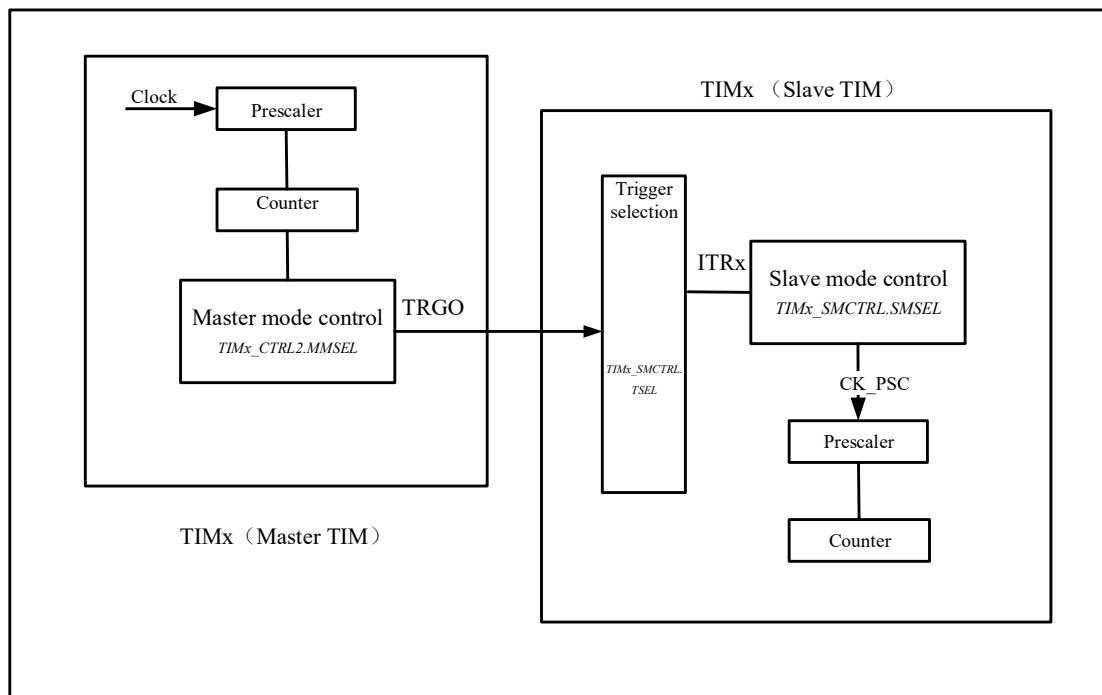
Same with advanced-control timer, refer to 9.3.15

### 10.3.14 Timer Synchronization

All TIMx are internally interconnected to each other. This implementation allows any master timer to provide trigger to reset, start, stop or provide a clock for the other slave timers. The master clock is used for internal counter and can be prescaled. Below figure shows a Block diagram of timer interconnection.

The synchronization function does not support dynamic change of the connection. User should configure and enable the slave timer before enable the master timer's trigger or clock.

Figure 10-22 Block Diagram of Timer Interconnection



#### 10.3.14.1 Master timer as a prescaler for another timer

TIM1 as a prescaler for TIM3. TIM1 is maser, TIM3 is slave.

User need to do the following steps for this configuration.

- Set TIM1\_CTRL2.MMSEL='010' to use the update event of TIM1 as trigger output.
- Configure TIM3\_SMCTRL.TSEL= '000' , and connect the TRGO of TIM1 to TIM3.

- Configure TIM3\_SMCTRL.SMSEL = '111', the slave mode controller will be configured in external clock mode 1.
- Start TIM3 by setting TIM3\_CTRL1.CNTEN = '1'.
- Start TIM1 by setting TIM1\_CTRL1.CNTEN = '1'.

*Note: If user select OCx as the trigger output of TIM1 by configuring MMSEL = '1xx', OCx rising edge will be used to drive TIM2.*

**10.3.14.2 Master timer to enable another timer**

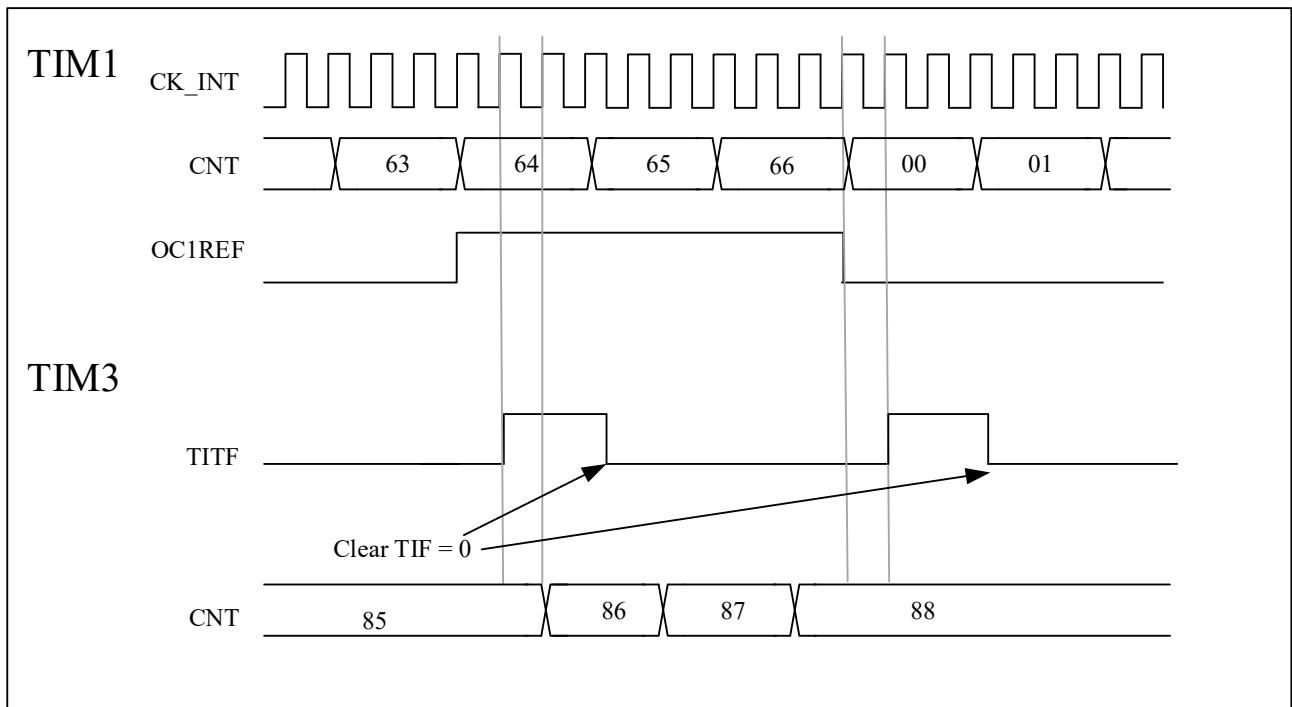
In this example, TIM3 is enabled by the output compare of TIM1. TIM3 counter will start to count after the OC1REF output from TIM1 is high. Both counters are clocked based on CK\_INT via a prescaler divide by 3 is performed ( $f_{CK\_CNT} = f_{CK\_INT}/3$ ).

The configuration steps are shown as below.

- Set TIM1\_CTRL2.MMSEL='100' to use the OC1REF of TIM1 as trigger output.
- Configure TIM1\_CCMOD1 register to configure the OC1REF output waveform.
- Set TIM3\_SMCTRL.TSEL = '000' to connect TIM1 trigger output to TIM3.
- Set TIM3\_SMCTRL.SMSEL = '101' to set TIM3 to gated mode.
- Set TIM3\_CTRL1.CNTEN= '1' to start TIM3.
- Set TIM1\_CTRL1.CNTEN= '1' to start TIM1.

*Note: The TIM3 clock is not synchronized with the TIM1 clock, this mode only affects the TIM3 counter enable signal.*

**Figure 10-23 TIM3 Gated by OC1REF of TIM1**

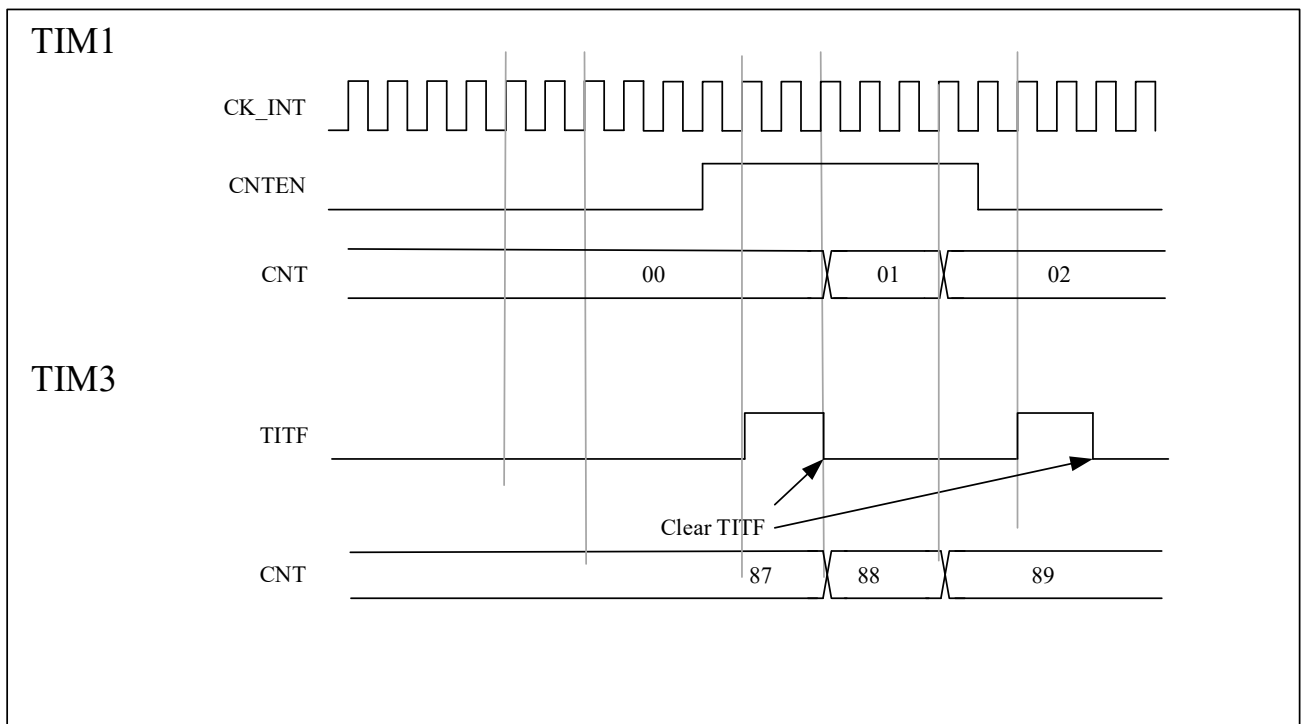


In the next example, TIM3 is gated by the enable signal of TIM1, TIM1 is stopped by setting TIM1.CTRL1.CNTEN = '0'. TIM3 counts on the divided internal clock only when TIM1 is enable. Both counters are clocked based on CK\_INT via a prescaler divide by 3 is performed ( $f_{CK\_CNT} = f_{CK\_INT}/3$ ).

The configuration steps are shown as below

- Set TIM1\_CTRL2.MMSEL='001' to use the enable signal of TIM1 as trigger output
- Set TIM3\_SMCTRL.TSEL = '000' to configure TIM3 to get the trigger input from TIM1
- Set TIM3\_SMCTRL.SMSEL = '101' to configure TIM3 in gated mode.
- Set TIM3\_CTRL1.CNTEN='1' to start TIM3.
- Set TIM1\_CTRL1.CNTEN='1' to start TIM1.
- Set TIM1\_CTRL1.CNTEN='0' to stop TIM1.

**Figure 10-24 TIM3 Gated by Enable Signal of TIM1**



**10.3.14.3 Master timer to start another timer**

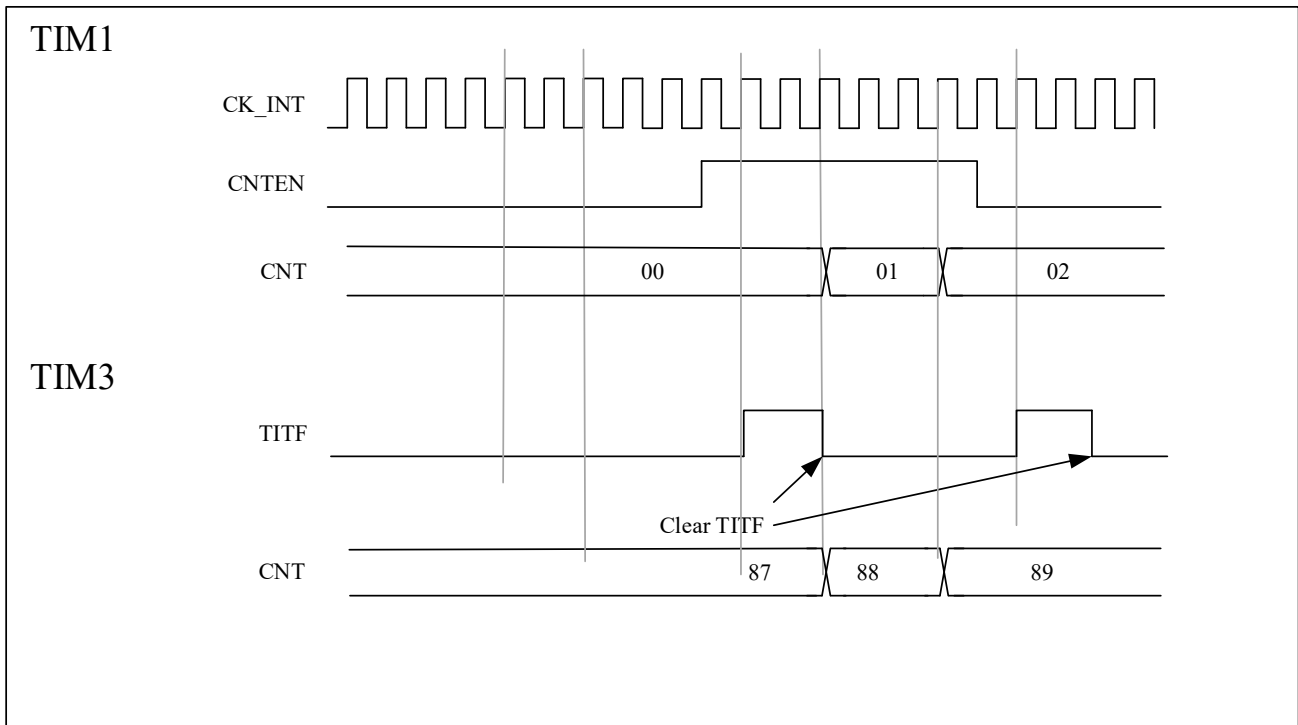
In this example, we can use update event as trigger source. TIM1 is master, TIM3 is slave.

The configuration steps are shown as below:

- Set TIM1\_CTRL2.MMSEL='010' to use the update event of TIM1 as trigger output
- Configure TIM1\_AR register to set the output period.
- Set TIM3\_SMCTRL.TSEL= '000' to connect TIM1 trigger output to TIM3.
- Set TIM3\_SMCTRL.SMSEL = '110' to set TIM3 to trigger mode.

- Set TIM1\_CTRL1.CNTEN=1 to start TIM1.

**Figure 10-25 Trigger TIM3 with An Update of TIM1**



**10.3.14.4 Start 2 timers synchronously using an external trigger**

In this example, TIM1 is enabled when TIM1's TI1 input rises, and TIM3 is enabled when TIM1 is enabled. To ensure the alignment of counters, TIM1 must be configured in master/slave mode. For TI1, TIM1 is the slave; for TIM3, TIM1 is the master.

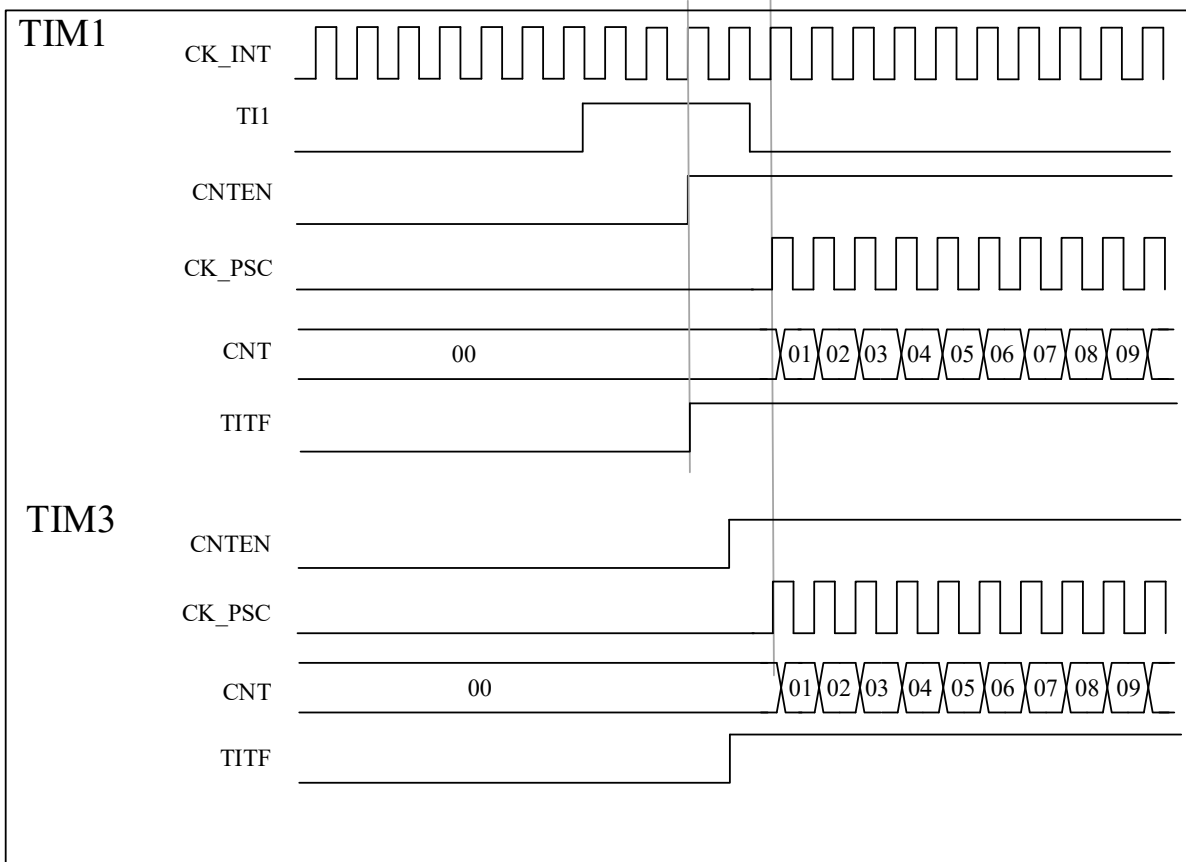
The configuration steps are shown as below:

- Set TIM1.MMSEL = '001' to use the enable signal as trigger output
- Set TIM1\_SMCTRL.TSEL = '100' to configure the TIM1 to slave mode and receive the trigger input of TI1.
- Set TIM1\_SMCTRL.SMSEL = '110' to configure TIM1 to trigger mode.
- Set TIM1\_SMCTRL.MSMD = '1' to configure TIM1 to master/slave mode.
- Set TIM3\_SMCTRL.TSEL = '000' to connect TIM1 trigger output to TIM3.
- Set TIM3\_SMCTRL.SMSEL = '110' to configure TIM3 to trigger mode.

When TI1 rising edge arrives, both timers start counting synchronously according to the internal clock, and both TITF flags are set simultaneously.

*The following figure shows a delay between CNTEN and CK\_PSC of TIM1 in master/slave mode.*

Figure 10-26 Triggers Timers 1 and 3 Using The TI1 Input of TIM1



### 10.3.15 Encoder Interface Mode

The encoder uses two inputs TI1 and TI2 as an interface and the counter counts on every edge change on TI1FP1 or TI2FP2. The counting direction is automatically controlled by hardware TIMx\_CTRL1.DIR. There are three types of encoder counting modes:

1. The counter only counts on the edge of TI1, TIMx\_SMCTRL.SMSEL = '001';
2. The counter only counts on the edge of TI2, TIMx\_SMCTRL.SMSEL = '010';
3. The counter counts on the edges of TI1 and TI2 at the same time, TIMx\_SMCTRL.SMSEL = '011';

The encoder interface is equivalent to using an external clock with direction selection, and the counter only counts continuously between 0 and the auto-reload value (TIMx\_AR.AR [15:0]). Therefore, it is necessary to configure the auto-reload register TIMx\_AR in advance.

*Note: Encoder mode and external clock mode 2 are not compatible and must not be selected together.*

The relationship between the counting direction and the encoder signals is shown in **Table 10-1**:

**Table 10-1 Counting Direction Versus Encoder Signals**

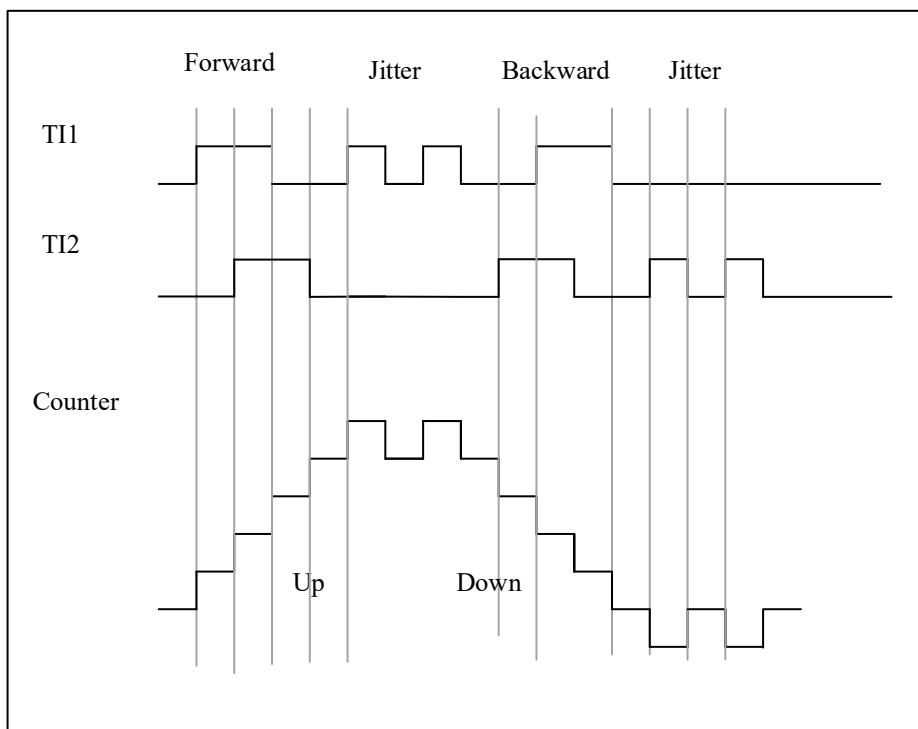
|  | Level On Opposite | TI1FP1 Signal | TI2FP2 Signal |
|--|-------------------|---------------|---------------|
|--|-------------------|---------------|---------------|

| Active Edge                | Signals<br>(TI1FP1 For TI2,<br>TI2FP2 For TI1) | Rising        | Falling       | Rising        | Falling       |
|----------------------------|--|---------------|---------------|---------------|---------------|
| Counting only at TI1       | High   | Counting down | Counting up   | Don't count   | Don't count   |
|                            | Low  | Counting up   | Counting down | Don't count   | Don't count   |
| Counting only at TI2       | High   | Don't count   | Don't count   | Counting up   | Counting down |
|                            | Low  | Don't count   | Don't count   | Counting down | Counting up   |
| Counting on<br>TI1 and TI2 | High   | Counting down | Counting up   | Counting up   | Counting down |
|                            | Low  | Counting up   | Counting down | Counting down | Counting up   |

Here is an example of an encoder with dual edge triggering selected to suppress input jitter:

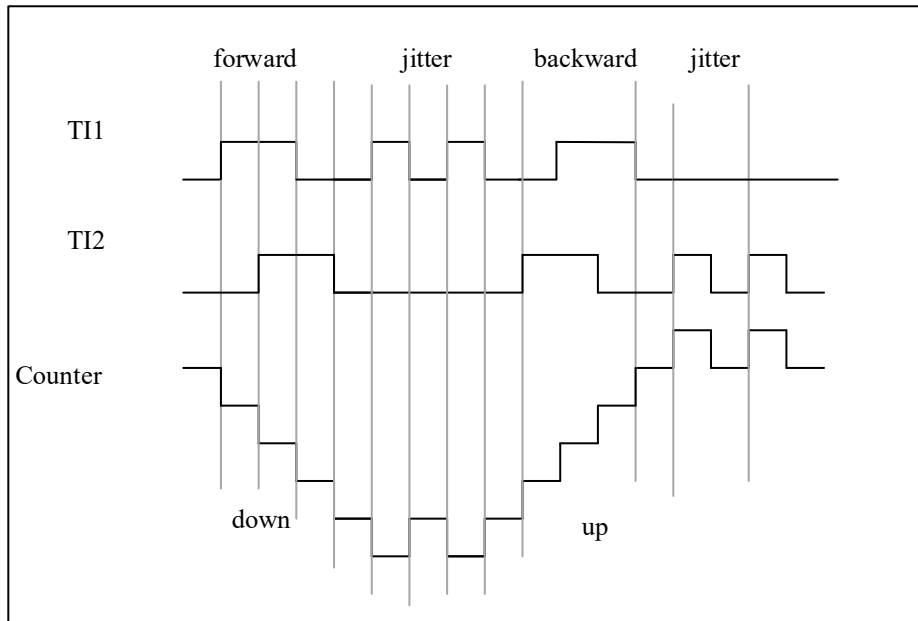
1. IC1FP1 is mapped to TI1 (TIMx\_CCMOD1.CC1SEL= '01'), IC1FP1 is not inverted (TIMx\_CCEN.CC1P= '0');
2. IC1FP2 is mapped to TI2 (TIMx\_CCMOD2.CC2SEL= '01'), IC2FP2 is not inverted (TIMx\_CCEN.CC2P= '0');
3. The input is valid on both rising and falling edges (TIMx\_SMCTRL.SMSEL = '011');
4. Enable counter TIMx\_CTRL1.CNTEN= '1';

**Figure 10-27 Example of Counter Operation in Encoder Interface Mode**



The following figure shows the example of counter behavior when IC1FP1 polarity is inverted (CC1P= '1', other configurations are the same as above)

Figure 10-28 Encoder Interface Mode Example with IC1FP1 Polarity Inverted



### 10.3.16 Interfacing with Hall Sensor

Please refer to 9.3.19

## 10.4 TIMx Register Description(x=3)

For abbreviations used in registers, see section 1.1

These peripheral registers can be operated as half word (16-bits) or one word (32-bits).

### 10.4.1 Register Overview

Table 10-2 Register Overview

| Offset | Register    | 31       | 30 | 29 | 28 | 27 | 26 | 25 | 24 | 23 | 22 | 21 | 20 | 19 | 18 | 17     | 16       | 15         | 14         | 13     | 12        | 11        | 10       | 9     | 8           | 7      | 6      | 5        | 4            | 3    | 2     | 1     | 0 |   |   |   |   |   |   |   |
|--------|-------------|----------|----|----|----|----|----|----|----|----|----|----|----|----|----|--------|----------|------------|------------|--------|-----------|-----------|----------|-------|-------------|--------|--------|----------|--------------|------|-------|-------|---|---|---|---|---|---|---|---|
| 000h   | TIMx_CTRL1  | Reserved |    |    |    |    |    |    |    |    |    |    |    |    |    | CLRSEL | Reserved | C3SEL      | C2SEL      | C1SEL  | Reserved  | CLKD[1:0] |          | ARPN  | CAMSEL[1:0] |        |        | DIR      | ONEPM        | UPRS | UPDIS | CNTEN |   |   |   |   |   |   |   |   |
|        | Reset Value | 0        |    |    |    |    |    |    |    |    |    |    |    |    |    | 0      | 0        | 0          | 0          | 0      | 0         | 0         | 0        | 0     | 0           | 0      | 0      | 0        | 0            | 0    | 0     | 0     | 0 | 0 | 0 | 0 | 0 | 0 | 0 | 0 |
| 004h   | TIMx_CTRL2  | Reserved |    |    |    |    |    |    |    |    |    |    |    |    |    | ETRSEL |          | TI1SEL     | MMSEL[2:0] |        |           | CCDSEL    | Reserved |       |             |        |        |          |              |      |       |       |   |   |   |   |   |   |   |   |
|        | Reset Value | 0        |    |    |    |    |    |    |    |    |    |    |    |    |    | 0      | 0        | 0          | 0          | 0      | 0         | 0         | 0        | 0     | 0           | 0      | 0      | 0        | 0            | 0    |       |       |   |   |   |   |   |   |   |   |
| 008h   | TIMx_SMCTRL | Reserved |    |    |    |    |    |    |    |    |    |    |    |    |    | EXTP   | EXCEN    | EXTPS[1:0] |            |        | EXTF[3:0] |           |          | MSMD  | TSEL[2:0]   |        |        | Reserved | SMSELEL[2:0] |      |       |       |   |   |   |   |   |   |   |   |
|        | Reset Value | 0        |    |    |    |    |    |    |    |    |    |    |    |    |    | 0      | 0        | 0          | 0          | 0      | 0         | 0         | 0        | 0     | 0           | 0      | 0      | 0        | 0            | 0    | 0     | 0     | 0 | 0 | 0 | 0 | 0 | 0 | 0 | 0 |
| 00Ch   | TIMx_DINTEN | Reserved |    |    |    |    |    |    |    |    |    |    |    |    |    | TDEN   | Reserved | CC4DEN     | CC3DEN     | CC2DEN | CC1DEN    | UDEN      | Reserved | TI1EN | Reserved    | CC4IEN | CC3IEN | CC2IEN   | CC1IEN       | UIEN |       |       |   |   |   |   |   |   |   |   |

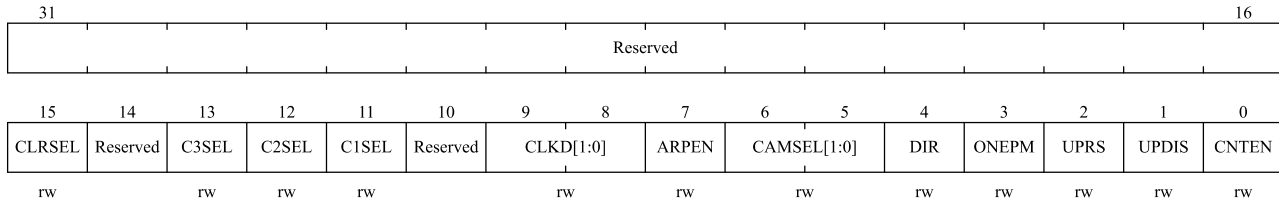


| Offset | Register                   | 31       | 30 | 29 | 28 | 27 | 26 | 25 | 24 | 23 | 22 | 21 | 20 | 19 | 18 | 17 | 16 | 15 | 14 | 13           | 12         | 11          | 10     | 9           | 8           | 7           | 6     | 5           | 4          | 3           | 2      | 1           | 0      |       |   |   |   |   |   |   |   |   |   |   |   |   |   |   |   |   |   |   |   |   |   |   |
|--------|----------------------------|----------|----|----|----|----|----|----|----|----|----|----|----|----|----|----|----|----|----|--------------|------------|-------------|--------|-------------|-------------|-------------|-------|-------------|------------|-------------|--------|-------------|--------|-------|---|---|---|---|---|---|---|---|---|---|---|---|---|---|---|---|---|---|---|---|---|---|
| 010h   | Reset Value                | 0        |    |    |    |    |    |    |    |    |    |    |    |    |    |    |    |    |    | 0            | 0          | 0           | 0      | 0           | 0           | 0           | 0     | 0           | 0          | 0           | 0      | 0           | 0      | 0     | 0 | 0 | 0 | 0 | 0 | 0 | 0 | 0 | 0 | 0 | 0 | 0 | 0 | 0 | 0 | 0 | 0 |   |   |   |   |   |
|        | TIMx_STS                   | Reserved |    |    |    |    |    |    |    |    |    |    |    |    |    |    |    |    |    | CC4OCF       | CC3OCF     | CC2OCF      | CC1OCF | Reserved    |             |             |       | OC1EN       | OC1MD[2:0] | OC4ITF      | OC3ITF | OC2ITF      | OC1ITF | UDITF |   |   |   |   |   |   |   |   |   |   |   |   |   |   |   |   |   |   |   |   |   |   |
| 014h   | TIMx_EVTGEN                | Reserved |    |    |    |    |    |    |    |    |    |    |    |    |    |    |    |    |    | TGN          | Reserved   |             |        |             | CC4GN       | CC3GN       | CC2GN | CC1GN       | UDGN       |             |        |             |        |       |   |   |   |   |   |   |   |   |   |   |   |   |   |   |   |   |   |   |   |   |   |   |
|        | Reset Value                | 0        |    |    |    |    |    |    |    |    |    |    |    |    |    |    |    |    |    | 0            | 0          | 0           | 0      | 0           | 0           | 0           | 0     | 0           | 0          | 0           | 0      | 0           | 0      | 0     | 0 | 0 | 0 | 0 | 0 | 0 | 0 | 0 | 0 | 0 | 0 | 0 | 0 | 0 | 0 | 0 | 0 | 0 | 0 |   |   |   |
| 018h   | TIMx_CCMOD1 Output compare | Reserved |    |    |    |    |    |    |    |    |    |    |    |    |    |    |    |    |    | OC2EN        | OC2MD[2:0] |             | OC2PEN | OC2PEN      | CC2SEL[1:0] |             | OC1EN | OC1MD[2:0]  |            | OC1PEN      | OC1PEN | CC1SEL[1:0] |        |       |   |   |   |   |   |   |   |   |   |   |   |   |   |   |   |   |   |   |   |   |   |   |
|        | Reset Value                | 0        |    |    |    |    |    |    |    |    |    |    |    |    |    |    |    |    |    | 0            | 0          | 0           | 0      | 0           | 0           | 0           | 0     | 0           | 0          | 0           | 0      | 0           | 0      | 0     | 0 | 0 | 0 | 0 | 0 | 0 | 0 | 0 | 0 | 0 | 0 | 0 | 0 | 0 | 0 | 0 | 0 | 0 | 0 | 0 |   |   |
| 018h   | TIMx_CCMOD1 Input capture  | Reserved |    |    |    |    |    |    |    |    |    |    |    |    |    |    |    |    |    | IC2F[3:0]    |            | IC2PSC[1:0] |        | CC2SEL[1:0] |             | IC1F[3:0]   |       | IC1PSC[1:0] |            | CC1SEL[1:0] |        |             |        |       |   |   |   |   |   |   |   |   |   |   |   |   |   |   |   |   |   |   |   |   |   |   |
|        | Reset Value                | 0        |    |    |    |    |    |    |    |    |    |    |    |    |    |    |    |    |    | 0            | 0          | 0           | 0      | 0           | 0           | 0           | 0     | 0           | 0          | 0           | 0      | 0           | 0      | 0     | 0 | 0 | 0 | 0 | 0 | 0 | 0 | 0 | 0 | 0 | 0 | 0 | 0 | 0 | 0 | 0 | 0 | 0 | 0 | 0 | 0 |   |
| 01Ch   | TIMx_CCMOD2 Output compare | Reserved |    |    |    |    |    |    |    |    |    |    |    |    |    |    |    |    |    | OC4EN        | OC4MD[2:0] |             | OC4PEN | OC4PEN      | CC4SEL[1:0] |             | OC3EN | OC3MD[2:0]  |            | OC3PEN      | OC3PEN | CC3SEL[1:0] |        |       |   |   |   |   |   |   |   |   |   |   |   |   |   |   |   |   |   |   |   |   |   |   |
|        | Reset Value                | 0        |    |    |    |    |    |    |    |    |    |    |    |    |    |    |    |    |    | 0            | 0          | 0           | 0      | 0           | 0           | 0           | 0     | 0           | 0          | 0           | 0      | 0           | 0      | 0     | 0 | 0 | 0 | 0 | 0 | 0 | 0 | 0 | 0 | 0 | 0 | 0 | 0 | 0 | 0 | 0 | 0 | 0 | 0 | 0 | 0 |   |
| 01Ch   | TIMx_CCMOD2 Input capture  | Reserved |    |    |    |    |    |    |    |    |    |    |    |    |    |    |    |    |    | IC4F[3:0]    |            | IC4PSC[1:0] |        | CC4SEL[1:0] |             | IC3F[3:0]   |       | IC3PSC[1:0] |            | CC3SEL[1:0] |        |             |        |       |   |   |   |   |   |   |   |   |   |   |   |   |   |   |   |   |   |   |   |   |   |   |
|        | Reset Value                | 0        |    |    |    |    |    |    |    |    |    |    |    |    |    |    |    |    |    | 0            | 0          | 0           | 0      | 0           | 0           | 0           | 0     | 0           | 0          | 0           | 0      | 0           | 0      | 0     | 0 | 0 | 0 | 0 | 0 | 0 | 0 | 0 | 0 | 0 | 0 | 0 | 0 | 0 | 0 | 0 | 0 | 0 | 0 | 0 | 0 | 0 |
| 020h   | TIMx_CCEN                  | Reserved |    |    |    |    |    |    |    |    |    |    |    |    |    |    |    |    |    | CC4P         | CC4EN      | Reserved    |        | CC3P        | CC3EN       | Reserved    |       | CC2P        | CC2EN      | Reserved    |        | CC1P        | CC1EN  |       |   |   |   |   |   |   |   |   |   |   |   |   |   |   |   |   |   |   |   |   |   |   |
|        | Reset Value                | 0        |    |    |    |    |    |    |    |    |    |    |    |    |    |    |    |    |    | 0            | 0          | 0           | 0      | 0           | 0           | 0           | 0     | 0           | 0          | 0           | 0      | 0           | 0      | 0     | 0 | 0 | 0 | 0 | 0 | 0 | 0 | 0 | 0 | 0 | 0 | 0 | 0 | 0 | 0 | 0 | 0 | 0 | 0 | 0 | 0 |   |
| 024h   | TIMx_CNT                   | Reserved |    |    |    |    |    |    |    |    |    |    |    |    |    |    |    |    |    | CNT[15:0]    |            |             |        |             |             |             |       |             |            |             |        |             |        |       |   |   |   |   |   |   |   |   |   |   |   |   |   |   |   |   |   |   |   |   |   |   |
|        | Reset Value                | 0        |    |    |    |    |    |    |    |    |    |    |    |    |    |    |    |    |    | 0            | 0          | 0           | 0      | 0           | 0           | 0           | 0     | 0           | 0          | 0           | 0      | 0           | 0      | 0     | 0 | 0 | 0 | 0 | 0 | 0 | 0 | 0 | 0 | 0 | 0 | 0 | 0 | 0 | 0 | 0 | 0 | 0 | 0 | 0 |   |   |
| 028h   | TIMx_PSC                   | Reserved |    |    |    |    |    |    |    |    |    |    |    |    |    |    |    |    |    | PSC[15:0]    |            |             |        |             |             |             |       |             |            |             |        |             |        |       |   |   |   |   |   |   |   |   |   |   |   |   |   |   |   |   |   |   |   |   |   |   |
|        | Reset Value                | 0        |    |    |    |    |    |    |    |    |    |    |    |    |    |    |    |    |    | 0            | 0          | 0           | 0      | 0           | 0           | 0           | 0     | 0           | 0          | 0           | 0      | 0           | 0      | 0     | 0 | 0 | 0 | 0 | 0 | 0 | 0 | 0 | 0 | 0 | 0 | 0 | 0 | 0 | 0 | 0 | 0 | 0 | 0 | 0 | 0 |   |
| 02Ch   | TIMx_AR                    | Reserved |    |    |    |    |    |    |    |    |    |    |    |    |    |    |    |    |    | AR[15:0]     |            |             |        |             |             |             |       |             |            |             |        |             |        |       |   |   |   |   |   |   |   |   |   |   |   |   |   |   |   |   |   |   |   |   |   |   |
|        | Reset Value                | 1        |    |    |    |    |    |    |    |    |    |    |    |    |    |    |    |    |    | 1            | 1          | 1           | 1      | 1           | 1           | 1           | 1     | 1           | 1          | 1           | 1      | 1           | 1      | 1     | 1 | 1 | 1 | 1 | 1 | 1 | 1 | 1 | 1 | 1 | 1 | 1 | 1 | 1 | 1 | 1 | 1 | 1 | 1 | 1 | 1 |   |
| 030h   | Reserved                   |          |    |    |    |    |    |    |    |    |    |    |    |    |    |    |    |    |    |              |            |             |        |             |             |             |       |             |            |             |        |             |        |       |   |   |   |   |   |   |   |   |   |   |   |   |   |   |   |   |   |   |   |   |   |   |
| 034h   | TIMx_CCDAT1                | Reserved |    |    |    |    |    |    |    |    |    |    |    |    |    |    |    |    |    | CCDAT1[15:0] |            |             |        |             |             |             |       |             |            |             |        |             |        |       |   |   |   |   |   |   |   |   |   |   |   |   |   |   |   |   |   |   |   |   |   |   |
|        | Reset Value                | 0        |    |    |    |    |    |    |    |    |    |    |    |    |    |    |    |    |    | 0            | 0          | 0           | 0      | 0           | 0           | 0           | 0     | 0           | 0          | 0           | 0      | 0           | 0      | 0     | 0 | 0 | 0 | 0 | 0 | 0 | 0 | 0 | 0 | 0 | 0 | 0 | 0 | 0 | 0 | 0 | 0 | 0 | 0 | 0 | 0 |   |
| 038h   | TIMx_CCDAT2                | Reserved |    |    |    |    |    |    |    |    |    |    |    |    |    |    |    |    |    | CCDAT2[15:0] |            |             |        |             |             |             |       |             |            |             |        |             |        |       |   |   |   |   |   |   |   |   |   |   |   |   |   |   |   |   |   |   |   |   |   |   |
|        | Reset Value                | 0        |    |    |    |    |    |    |    |    |    |    |    |    |    |    |    |    |    | 0            | 0          | 0           | 0      | 0           | 0           | 0           | 0     | 0           | 0          | 0           | 0      | 0           | 0      | 0     | 0 | 0 | 0 | 0 | 0 | 0 | 0 | 0 | 0 | 0 | 0 | 0 | 0 | 0 | 0 | 0 | 0 | 0 | 0 | 0 | 0 | 0 |
| 03Ch   | TIMx_CCDAT3                | Reserved |    |    |    |    |    |    |    |    |    |    |    |    |    |    |    |    |    | CCDAT3[15:0] |            |             |        |             |             |             |       |             |            |             |        |             |        |       |   |   |   |   |   |   |   |   |   |   |   |   |   |   |   |   |   |   |   |   |   |   |
|        | Reset Value                | 0        |    |    |    |    |    |    |    |    |    |    |    |    |    |    |    |    |    | 0            | 0          | 0           | 0      | 0           | 0           | 0           | 0     | 0           | 0          | 0           | 0      | 0           | 0      | 0     | 0 | 0 | 0 | 0 | 0 | 0 | 0 | 0 | 0 | 0 | 0 | 0 | 0 | 0 | 0 | 0 | 0 | 0 | 0 | 0 | 0 | 0 |
| 040h   | TIMx_CCDAT4                | Reserved |    |    |    |    |    |    |    |    |    |    |    |    |    |    |    |    |    | CCDAT4[15:0] |            |             |        |             |             |             |       |             |            |             |        |             |        |       |   |   |   |   |   |   |   |   |   |   |   |   |   |   |   |   |   |   |   |   |   |   |
|        | Reset Value                | 0        |    |    |    |    |    |    |    |    |    |    |    |    |    |    |    |    |    | 0            | 0          | 0           | 0      | 0           | 0           | 0           | 0     | 0           | 0          | 0           | 0      | 0           | 0      | 0     | 0 | 0 | 0 | 0 | 0 | 0 | 0 | 0 | 0 | 0 | 0 | 0 | 0 | 0 | 0 | 0 | 0 | 0 | 0 | 0 | 0 | 0 |
| 044h   | Reserved                   |          |    |    |    |    |    |    |    |    |    |    |    |    |    |    |    |    |    |              |            |             |        |             |             |             |       |             |            |             |        |             |        |       |   |   |   |   |   |   |   |   |   |   |   |   |   |   |   |   |   |   |   |   |   |   |
| 048h   | TIMx_DCTRL                 | Reserved |    |    |    |    |    |    |    |    |    |    |    |    |    |    |    |    |    | DBLEN[4:0]   |            |             |        | Reserved    |             | DBADDR[4:0] |       |             |            |             |        |             |        |       |   |   |   |   |   |   |   |   |   |   |   |   |   |   |   |   |   |   |   |   |   |   |
|        | Reset Value                | 0        |    |    |    |    |    |    |    |    |    |    |    |    |    |    |    |    |    | 0            | 0          | 0           | 0      | 0           | 0           | 0           | 0     | 0           | 0          | 0           | 0      | 0           | 0      | 0     | 0 | 0 | 0 | 0 | 0 | 0 | 0 | 0 | 0 | 0 | 0 | 0 | 0 | 0 | 0 | 0 | 0 | 0 | 0 | 0 | 0 | 0 |
| 04Ch   | TIMx_DADDR                 | Reserved |    |    |    |    |    |    |    |    |    |    |    |    |    |    |    |    |    | BURST[15:0]  |            |             |        |             |             |             |       |             |            |             |        |             |        |       |   |   |   |   |   |   |   |   |   |   |   |   |   |   |   |   |   |   |   |   |   |   |
|        | Reset Value                | 0        |    |    |    |    |    |    |    |    |    |    |    |    |    |    |    |    |    | 0            | 0          | 0           | 0      | 0           | 0           | 0           | 0     | 0           | 0          | 0           | 0      | 0           | 0      | 0     | 0 | 0 | 0 | 0 | 0 | 0 | 0 | 0 | 0 | 0 | 0 | 0 | 0 | 0 | 0 | 0 | 0 | 0 | 0 | 0 | 0 | 0 |

### 10.4.2 Control Register 1 (TIMx\_CTRL1)

Offset address: 0x00

Reset value: 0x0000 0000



| Bit Field | Name        | Description   |
|-----------|-------------|---|
| 31:16     | Reserved    | Reserved, the reset value must be maintained  |
| 15        | CLRSEL      | OCxREF clear selection<br>0: Select the external OCxREF clear from ETR<br>1: Select the internal OCxREF clear from comparator   |
| 14        | Reserved    | Reserved, the reset value must be maintained  |
| 13        | C3SEL       | Channel 3 Selection<br>0: Select external CH3 (from IOM) signal<br>1: Reserved  |
| 12        | C2SEL       | Channel 2 Selection<br>0: Select external CH2 (from IOM) signal<br>1: Reserved  |
| 11        | C1SEL       | Channel 1 selection<br>0: Select external CH1 signal from IOM<br>1: Select internal CH1 signal from COMP  |
| 10        | Reserved    | Reserved, the reset value must be maintained  |
| 9:8       | CLKD[1:0]   | Clock division<br>CLKD[1:0] indicates the division ratio between CK_INT (timer clock) and t <sub>DTS</sub> (clock used for dead-time generator and digital filters (ETR, Tlx))<br>00: t <sub>DTS</sub> = t <sub>CK_INT</sub><br>01: t <sub>DTS</sub> = 2 × t <sub>CK_INT</sub><br>10: t <sub>DTS</sub> = 4 × t <sub>CK_INT</sub><br>11: Reserved, do not use this configuration |
| 7         | ARPEN       | ARPEN: Auto-reload preload enable<br>0: Shadow register disable for TIMx_AR register<br>1: Shadow register enable for TIMx_AR register  |
| 6:5       | CAMSEL[1:0] | Center-aligned mode selection<br>00: Edge-aligned mode. TIMx_CTRL1.DIR specifies up-counting or down-counting.<br>01: Center-aligned mode 1. The counter counts in center-aligned mode, and the output compare interrupt flag bit is set to 1 when down-counting.   |

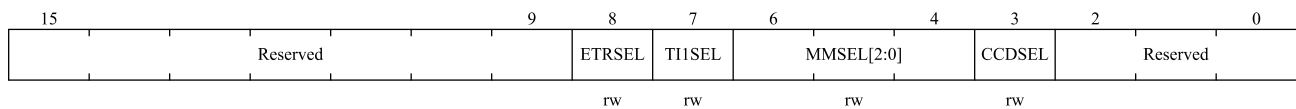
| Bit Field | Name  | Description   |
|-----------|-------|---|
|           |       | <p>10: Center-aligned mode 2. The counter counts in center-aligned mode, and the output compare interrupt flag bit is set to 1 when up-counting.</p> <p>11: Center-aligned mode 3. The counter counts in center-aligned mode, and the output compare interrupt flag bit is set to 1 when up-counting or down-counting.</p> <p><i>Note: Switching from edge-aligned mode to center-aligned mode is not allowed when the counter is still enabled (TIMx_CTRL1.CNTEN = 1).</i></p>   |
| 4         | DIR   | <p>Direction</p> <p>0: Up-counting</p> <p>1: Down-counting</p> <p><i>Note: This bit is read-only when the counter is configured in center-aligned mode or encoder mode.</i></p>   |
| 3         | ONEPM | <p>One-pulse mode</p> <p>0: Disable one-pulse mode, the counter counts are not affected when an update event occurs.</p> <p>1: Enable one-pulse mode, the counter stops counting when the next update event occurs (clearing TIMx_CTRL1.CNTEN bit)</p>  |
| 2         | UPRS  | <p>Update request source</p> <p>This bit is used to select the UEV event sources by software.</p> <p>0: If update interrupt or DMA request is enabled, any of the following events will generate an update interrupt or DMA request:</p> <ul style="list-style-type: none"> <li>– Counter overflow/underflow</li> <li>– The TIMx_EVTGEN.UDGN bit is set</li> <li>– Update generation from the slave mode controller</li> </ul> <p>1: If update interrupt or DMA request is enabled, only counter overflow/underflow will generate update interrupt or DMA request</p>   |
| 1         | UPDIS | <p>Update disable</p> <p>This bit is used to enable/disable the Update event (UEV) events generation by software.</p> <p>0: Enable UEV. And UEV will be generated if one of following condition been fulfilled:</p> <ul style="list-style-type: none"> <li>– Counter overflow/underflow</li> <li>– The TIMx_EVTGEN.UDGN bit is set</li> <li>– Update generation from the slave mode controller</li> </ul> <p>Shadow registers will update with preload value.</p> <p>1: UEV disabled. No update event is generated, and the shadow registers (AR, PSC, and CCDATx) keep their values. If the TIMx_EVTGEN.UDGN bit is set or a hardware reset is issued by the slave mode controller, the counter and prescaler are reinitialized.</p> |
| 0         | CNTEN | <p>Counter Enable</p> <p>0: Disable counter</p> <p>1: Enable counter</p> <p><i>Note: external clock, gating mode and encoder mode can only operate after</i></p>  |

| Bit Field | Name | Description  |
|-----------|------|--|
|           |      | <i>TIMx_CTRL1.CNTEN bit is set in the software. Trigger mode can automatically set TIMx_CTRL1.CNTEN bit by hardware.</i> |

### 10.4.3 Control Register 2 (TIMx\_CTRL2)

Offset address: 0x04

Reset value: 0x0000



| Bit Field | Name       | Description   |
|-----------|------------|---|
| 15:9      | Reserved   | Reserved, the reset value must be maintained  |
| 8         | ETRSEL     | External Triggered Selection memory (ETR Selection)<br>0: Select external ETR (from IOM) signal;<br>1: Reserved   |
| 7         | TI1SEL     | TI1 selection<br>0: TIMx_CH1 pin connected to TI1 input.<br>1: TIMx_CH1, TIMx_CH2, and TIMx_CH3 pins are XOR connected to the TI1 input.  |
| 6:4       | MMSEL[2:0] | Master Mode Selection<br>These 3 bits (TIMx_CTRL2. MMSEL [2:0]) are used to select the synchronization information (TRGO) sent to the slave timer in the master mode. Possible combinations are as follows:<br>000: Reset –When the TIMx_EVTGEN.UDGN is set or a reset is generated by the slave mode controller, a TRGO pulse occurs. And in the latter case, the signal on TRGO is delayed compared to the actual reset.<br>001: Enable - The TIMx_CTRL1.CNTEN bit is used as the trigger output (TRGO). Sometimes you need to start multiple timers at the same time or enable slave timer for a period of time.<br>The counter enable signal is set when TIMx_CTRL1.CNTEN bit is set or the trigger input in gated mode is high.<br>When the counter enable signal is controlled by the trigger input, there is a delay on TRGO except if the master/slave mode is selected (see the description of the TIMx_SMCTRL.MSMD bit).<br>010: Update - The update event is selected as the trigger output (TRGO). For example, a master timer clock can be used as a slave timer prescaler.<br>011: Compare pulse - Triggers the output to send a positive pulse (TRGO) when the TIMx_STS.CC1ITF is to be set (even if it is already high), when a capture or a comparison succeeds.<br>100: Compare - OC1REF signal is used as the trigger output (TRGO).<br>101: Compare - OC2REF signal is used as the trigger output (TRGO).<br>110: Compare - OC3REF signal is used as the trigger output (TRGO). |

| Bit Field | Name     | Description   |
|-----------|----------|---|
|           |          | 111: Compare - OC4REF signal is used as the trigger output (TRGO).  |
| 3         | CCDSEL   | Capture/compare DMA selection<br>0: When a CCx event occurs, a DMA request for CCx is sent.<br>1: When an update event occurs, a DMA request for CCx is sent. |
| 2:0       | Reserved | Reserved, the reset value must be maintained  |

#### 10.4.4 Slave Mode Control Register (TIMx\_SMCTRL)

Offset address: 0x08

Reset value: 0x0000

|      |       |            |    |           |   |      |   |           |          |   |            |
|------|-------|------------|----|-----------|---|------|---|-----------|----------|---|------------|
| 15   | 14    | 13         | 12 | 11        | 8 | 7    | 6 | 4         | 3        | 2 | 0          |
| EXTP | EXCEN | EXTPS[1:0] |    | EXTF[3:0] |   | MSMD |   | TSEL[2:0] | Reserved |   | SMSEL[2:0] |
| rw   | rw    | rw         |    | rw        |   | rw   |   | rw        |          |   | rw         |

| Bit Field | Name       | Description  |
|-----------|------------|--|
| 15        | EXTP       | External trigger polarity<br>This bit is used to select whether the trigger operation is to use ETR or the inversion of ETR.<br>0: ETR active at high level or rising edge.<br>1: ETR active at low level or falling edge.   |
| 14        | EXCEN      | External clock enable<br>This bit is used to enable external clock mode 2, and the counter is driven by any effective edge on the ETRF signal in this mode.<br>0: External clock mode 2 disable.<br>1: External clock mode 2 enable.<br><i>Note 1: When external clock mode 1 and external clock mode 2 are enabled at the same time, the input of the external clock is ETRF.</i><br><i>Note 2: The following slave modes can be used simultaneously with external clock mode 2: reset mode, gated mode and trigger mode; However, TRGI cannot connect to ETRF (TIMx_SMCTRL.TSEL ≠ '111').</i><br><i>Note 3: Setting the TIMx_SMCTRL.EXCEN bit has the same effect as selecting external clock mode 1 and connecting TRGI to ETRF (TIMx_SMCTRL.SMSEL = 111 and TIMx_SMCTRL.TSEL = 111).</i> |
| 13:12     | EXTPS[1:0] | External trigger prescaler<br>The frequency of the external trigger signal ETRP must be at most 1/4 of TIMxCLK frequency. When a faster external clock is input, a prescaler can be used to reduce the frequency of ETRP.<br>00: Prescaler disable<br>01: ETRP frequency divided by 2<br>10: ETRP frequency divided by 4<br>11: ETRP frequency divided by 8  |

| Bit Field | Name      | Description   |
|-----------|-----------|---|
| 11:8      | EXTF[3:0] | <p>External trigger filter</p> <p>These bits are used to define the frequency at which the ETRP signal is sampled and the bandwidth of the ETRP digital filtering. In effect, the digital filter is an event counter that generates a validate output after consecutive N events are recorded.</p> <p>0000: No filter, sampling at <math>f_{DTS}</math></p> <p>0001: <math>f_{SAMPLING} = f_{CK\_INT}</math>, N = 2</p> <p>0010: <math>f_{SAMPLING} = f_{CK\_INT}</math>, N = 4</p> <p>0011: <math>f_{SAMPLING} = f_{CK\_INT}</math>, N = 8</p> <p>0100: <math>f_{SAMPLING} = f_{DTS}/2</math>, N = 6</p> <p>0101: <math>f_{SAMPLING} = f_{DTS}/2</math>, N = 8</p> <p>0110: <math>f_{SAMPLING} = f_{DTS}/4</math>, N = 6</p> <p>0111: <math>f_{SAMPLING} = f_{DTS}/4</math>, N = 8</p> <p>1000: <math>f_{SAMPLING} = f_{DTS}/8</math>, N = 6</p> <p>1001: <math>f_{SAMPLING} = f_{DTS}/8</math>, N = 8</p> <p>1010: <math>f_{SAMPLING} = f_{DTS}/16</math>, N = 5</p> <p>1011: <math>f_{SAMPLING} = f_{DTS}/16</math>, N = 6</p> <p>1100: <math>f_{SAMPLING} = f_{DTS}/16</math>, N = 8</p> <p>1101: <math>f_{SAMPLING} = f_{DTS}/32</math>, N = 5</p> <p>1110: <math>f_{SAMPLING} = f_{DTS}/32</math>, N = 6</p> <p>1111: <math>f_{SAMPLING} = f_{DTS}/32</math>, N = 8</p> |
| 7         | MSMD      | <p>Master/ Slave mode</p> <p>0: No action</p> <p>1: Events on the trigger input (TRGI) are delayed to allow a perfect synchronization between the current timer (via TRGO) and its slaves. This is useful when several timers are required to be synchronized to a single external event.</p>   |
| 6:4       | TSEL[2:0] | <p>Trigger selection</p> <p>These 3 bits are used to select the trigger input of the synchronous counter.</p> <p>000: Internal trigger 0 (ITR0) 100: TI1 edge detector (TI1F_ED)</p> <p>001: Internal trigger 1 (ITR1) 101: Filtered timer input 1 (TI1FP1)</p> <p>010: Internal trigger 2 (ITR2) 110: Filtered timer input 2 (TI2FP2)</p> <p>011: Internal trigger 3 (ITR3) 111: External triggered Input (ETRF)</p> <p>For more details on ITRx, see Table 10-3 below.</p> <p><i>Note: These bits must be changed only when not in use (e. g. TIMx_SMCTRL.SMSEL=000) to avoid false edge detection at the transition.</i></p>   |
| 3         | Reserved  | Reserved, the reset value must be maintained  |

| Bit Field | Name       | Description   |
|-----------|------------|---|
| 2:0       | SMSEL[2:0] | <p>Slave mode selection</p> <p>When an external signal is selected, the effective edge of the trigger signal (TRGI) is linked to the selected external input polarity (see input control register and control register description)</p> <p>000: Disable slave mode. If TIMx_CTRL1.CNTEN = 1, the prescaler is driven directly by the internal clock.</p> <p>001: Encoder mode 1. According to the level of TI2FP2, the counter up-counting or down-counting on the edge of TI1FP1.</p> <p>010: Encoder mode 2. According to the level of TI1FP1, the counter up-counting or down-counting on the edge of TI2FP2.</p> <p>011: Encoder mode 3. According to the input level of another signal, the counter up-counting or down-counting on the edges of TI2FP1 and TI2FP2.</p> <p>100: Reset mode. On the rising edge of the selected trigger input (TRGI), the counter is reinitialized and the shadow register is updated.</p> <p>101: Gated mode. When the trigger input (TRGI) is high, the clock of the counter is enabled. Once the trigger input becomes low, the counter stops counting, but is not reset. In this mode, the start and stop of the counter are controlled.</p> <p>110: Trigger mode. When a rising edge occurs on the trigger input (TRGI), the counter is started but not reset. In this mode, only the start of the counter is controlled.</p> <p>111: External clock mode 1. The counter is clocked by the rising edge of the selected trigger input (TRGI).</p> <p><i>Note: Do not use gated mode if TI1F_ED is selected as the trigger input (TIMx_SMCTRL.TSEL=100). This is because TI1F_ED outputs a pulse for each TI1F transition, whereas gated mode checks the level of the triggered input.</i></p> |

**Table 10-3 TIMx Internal Trigger Connection**

| Slave Timer | ITR0 (TSEL = 000) | ITR1 (TSEL = 001) | ITR2 (TSEL = 010) | ITR3 (TSEL = 011) |
|-------------|-------------------|-------------------|-------------------|-------------------|
| TIM3        | TIM1              | NA                | NA                | NA                |

### 10.4.5 DMA/Interrupt Enable Registers (TIMx\_DINTEN)

Offset address: 0x0C

Reset value: 0x0000

|          |      |          |        |        |        |        |      |          |      |          |        |        |        |        |      |
|----------|------|----------|--------|--------|--------|--------|------|----------|------|----------|--------|--------|--------|--------|------|
| 15       | 14   | 13       | 12     | 11     | 10     | 9      | 8    | 7        | 6    | 5        | 4      | 3      | 2      | 1      | 0    |
| Reserved | TDEN | Reserved | CC4DEN | CC3DEN | CC2DEN | CC1DEN | UDEN | Reserved | TIEN | Reserved | CC4IEN | CC3IEN | CC2IEN | CC1IEN | UIEN |
|          | rw   |          | rw     | rw     | rw     | rw     | rw   |          | rw   |          | rw     | rw     | rw     | rw     | rw   |

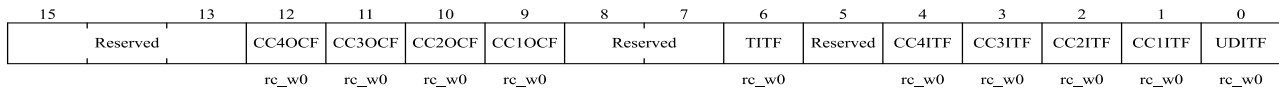
| Bit Field | Name     | Description   |
|-----------|----------|---|
| 15        | Reserved | Reserved, the reset value must be maintained  |
| 14        | TDEN     | Trigger DMA request enable<br>0: Disable trigger DMA request<br>1: Enable trigger DMA request                               |
| 13        | Reserved | Reserved, the reset value must be maintained  |
| 12        | CC4DEN   | Capture/Compare 4 DMA request enable<br>0: Disable capture/compare 4 DMA request<br>1: Enable capture/compare 4 DMA request |
| 11        | CC3DEN   | Capture/Compare 3 DMA request enable<br>0: Disable capture/compare 3 DMA request<br>1: Enable capture/compare 3 DMA request |
| 10        | CC2DEN   | Capture/Compare 2 DMA request enable<br>0: Disable capture/compare 2 DMA request<br>1: Enable capture/compare 2 DMA request |
| 9         | CC1DEN   | Capture/Compare 1 DMA request enable<br>0: Disable capture/compare 1 DMA request<br>1: Enable capture/compare 1 DMA request |
| 8         | UDEN     | Update DMA request enable<br>0: Disable update DMA request<br>1: Enable update DMA request                                  |
| 7         | Reserved | Reserved, the reset value must be maintained  |
| 6         | TIEN     | Trigger interrupt enable<br>0: Disable trigger interrupt<br>1: Enable trigger interrupt                                     |
| 5         | Reserved | Reserved, the reset value must be maintained  |
| 4         | CC4IEN   | Capture/Compare 4 interrupt enable<br>0: Disable capture/compare 4 interrupt<br>1: Enable capture/compare 4 interrupt       |
| 3         | CC3IEN   | Capture/Compare 3 interrupt enable<br>0: Disable capture/compare 3 interrupt<br>1: Enable capture/compare 3 interrupts      |
| 2         | CC2IEN   | Capture/Compare 2 interrupt enable<br>0: Disable capture/compare 2 interrupt<br>1: Enables capture/compare 2 interrupts     |
| 1         | CC1IEN   | Capture/Compare 1 interrupt enable<br>0: Disable capture/compare 1 interrupt<br>1: Enables capture/comparing 1 interrupt    |
| 0         | UIEN     | Update interrupt enable<br>0: Disable update interrupt<br>1: Enables update interrupt                                       |



### 10.4.6 Status Registers (TIMx\_STS)

Offset address: 0x10

Reset value: 0x0000



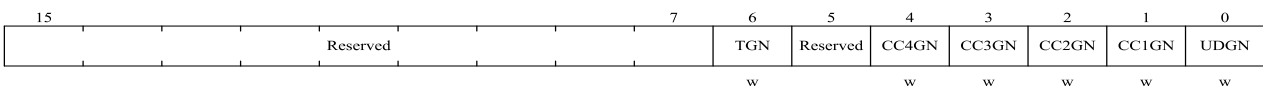
| Bit Field | Name     | Description   |
|-----------|----------|---|
| 15:13     | Reserved | Reserved, the reset value must be maintained  |
| 12        | CC4OCF   | Capture/Compare 4 overcapture flag<br>See TIMx_STS.CC1OCF description.  |
| 11        | CC3OCF   | Capture/Compare 3 overcapture flag<br>See TIMx_STS.CC1OCF description.  |
| 10        | CC2OCF   | Capture/Compare 2 overcapture flags<br>See TIMx_STS.CC1OCF description.   |
| 9         | CC1OCF   | Capture/Compare 1 overcapture flag<br>This bit is set by hardware only when the corresponding channel is configured in input capture mode. Cleared by software writing 0.<br>0: No overcapture occurred<br>1: TIMx_STS.CC1ITF was already set when the value of the counter has been captured in the TIMx_CC DAT1 register.                     |
| 8:7       | Reserved | Reserved, the reset value must be maintained  |
| 6         | TITF     | Trigger interrupt flag<br>This bit is set by hardware when an effective edge is detected on the TRGI input when the slave mode controller is in a mode other than gated. This bit is set by hardware when any edge in gated mode is detected. This bit is cleared by software.<br>0: No trigger event occurred<br>1: Trigger interrupt occurred |
| 5         | Reserved | Reserved, the reset value must be maintained  |
| 4         | CC4ITF   | Capture/Compare 4 interrupt flag<br>See TIMx_STS.CC1ITF description.  |
| 3         | CC3ITF   | Capture/Compare 3 interrupt flag<br>See TIMx_STS.CC1ITF description.  |
| 2         | CC2ITF   | Capture/Compare 2 interrupt flag<br>See TIMx_STS.CC1ITF description.  |
| 1         | CC1ITF   | Capture/Compare 1 interrupt flag<br><b>When the corresponding channel of CC1 is in output mode:</b><br>Except in center-aligned mode, this bit is set by hardware when the counter value is the same as the compare value (see TIMx_CTRL1.CAMSEL bit description). This bit is cleared by software.<br>0: No match occurred.                    |

| Bit Field | Name  | Description   |
|-----------|-------|---|
|           |       | <p>1: The value of TIMx_CNT is the same as the value of TIMx_CCDAT1.</p> <p>When the value of TIMx_CCDAT1 is greater than the value of TIMx_AR, the TIMx_STS.CC1ITF bit will go high if the counter overflows (in up-counting and up/down-counting modes) and underflows in down-counting mode.</p> <p><b>When the corresponding channel of CC1 is in input mode:</b></p> <p>This bit is set by hardware when the capture event occurs. This bit is cleared by software or by reading TIMx_CCDAT1.</p> <p>0: No input capture occurred.</p> <p>1: Input capture occurred. Counter value has captured in the TIMx_CCDAT1. An edge with the same polarity as selected has been detected on IC1.</p> |
| 0         | UDITF | <p>Update interrupt flag</p> <p>This bit is set by hardware when an update event occurs under the following conditions:</p> <ul style="list-style-type: none"> <li>– When TIMx_CTRL1.UPDIS = 0, overflow or underflow (An update event is generated).</li> <li>– When TIMx_CTRL1.UPRS = 0, TIMx_CTRL1.UPDIS = 0, and set the TIMx_EVTGEN.UDGN bit by software to reinitialize the CNT.</li> <li>– When TIMx_CTRL1.UPRS = 0, TIMx_CTRL1.UPDIS = 0, and the counter CNT is reinitialized by the trigger event. (See TIMx_SMCTRL Register description)</li> </ul> <p>This bit is cleared by software.</p> <p>0: No update event occurred</p> <p>1: Update interrupt occurred</p>                     |

### 10.4.7 Event Generation Registers (TIMx\_EVTGEN)

Offset address: 0x14

Reset values: 0 x0000



| Bit Field | Name     | Description  |
|-----------|----------|--|
| 15: 7     | Reserved | Reserved, the reset value must be maintained.  |
| 6         | TGN      | <p>Trigger generation</p> <p>This bit can generate a trigger event when set by software. And at this time TIMx_STS.TITF = 1, if the corresponding interrupt and DMA are enabled, the corresponding interrupt and DMA will be generated. This bit is automatically cleared by hardware.</p> <p>0: No action</p> <p>1: Generated a trigger event</p> |
| 5         | Reserved | Reserved, the reset value must be maintained   |

| Bit Field | Name  | Description  |
|-----------|-------|--|
| 4         | CC4GN | Capture/Compare 4 generation<br>See TIMx_EVTGEN.CC1GN description.   |
| 3         | CC3GN | Capture/Compare 3 generation<br>See TIMx_EVTGEN.CC1GN description.   |
| 2         | CC2GN | Capture/Compare 2 generation<br>See TIMx_EVTGEN.CC1GN description.   |
| 1         | CC1GN | Capture/Compare 1 generation<br>This bit can generate a capture/compare event when set by software. This bit is automatically cleared by hardware.<br>When the corresponding channel of CC1 is in output mode:<br>The TIMx_STS.CC1ITF flag will be pulled high, if the corresponding interrupt and DMA are enabled, the corresponding interrupt and DMA will be generated.<br>When the corresponding channel of CC1 is in input mode:<br>TIMx_CCDAT1 will capture the current counter value, and the TIMx_STS.CC1ITF flag will be pulled high, if the corresponding interrupt and DMA are enabled, the corresponding interrupt and DMA will be generated. If The IMx_STS.CC1ITF is already pulled high, pull TIMx_STS.CC1OCF high.<br>0: No action<br>1: Generated a CC1 capture/compare event |
| 0         | UDGN  | Update generation<br>This bit can generate an update event when set by software. And at this time the counter will be reinitialized, the prescaler counter will be cleared, the counter will be cleared in center-aligned or up-counting mode, but take TIMx_AR in down-counting mode the value of the register. This bit is automatically cleared by hardware.<br>0: No action<br>1: Generated an update event  |

### 10.4.8 Capture/Compare Mode Register 1 (TIMx\_CCMOD1)

Offset address: 0x18

Reset value: 0x0000

Channels can be used for input (capture mode) or output (compare mode), and the direction of the channel is defined by the corresponding CCxSEL bit. The other bits of the register act differently in input and output modes. OCx describes the function of a channel in output mode, ICx describes the function of a channel in input mode. Hence, please note that the same bit can have different meanings for output mode and for input mode.

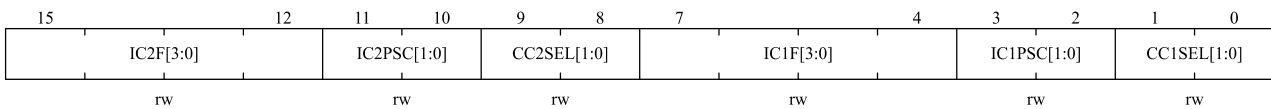
Output compare mode:

|        |            |    |        |        |             |   |        |            |   |        |        |             |   |
|--------|------------|----|--------|--------|-------------|---|--------|------------|---|--------|--------|-------------|---|
| 15     | 14         | 12 | 11     | 10     | 9           | 8 | 7      | 6          | 4 | 3      | 2      | 1           | 0 |
| OC2CEN | OC2MD[2:0] |    | OC2PEN | OC2FEN | CC2SEL[1:0] |   | OC1CEN | OC1MD[2:0] |   | OC1PEN | OC1FEN | CC1SEL[1:0] |   |
| rw     | rw         |    | rw     | rw     | rw          |   | rw     | rw         |   | rw     | rw     | rw          |   |

| Bit Field | Name        | Description   |
|-----------|-------------|---|
| 15        | OC2CEN      | Output Compare 2 clear enable   |
| 14:12     | OC2MD[2:0]  | Output Compare 2 mode   |
| 11        | OC2PEN      | Output Compare 2 preload enable   |
| 10        | OC2FEN      | Output Compare 2 fast enable  |
| 9:8       | CC2SEL[1:0] | <p>Capture/compare 2 selection</p> <p>These bits are used to select the input/output and input mapping of the channel</p> <p>00: CC2 channel is configured as output</p> <p>01: CC2 channel is configured as input, IC2 is mapped on TI2</p> <p>10: CC2 channel is configured as input, IC2 is mapped on TI1</p> <p>11: CC2 channel is configured as input, IC2 is mapped on TRC. This mode is only active when the internal trigger input is selected by TIMx_SMCTRL.TSEL.</p> <p><i>Note: CC2SEL is writable only when the channel is off (TIMx_CCEN.CC2EN = 0).</i></p>  |
| 7         | OC1CEN      | <p>Output Compare 1 clear enable</p> <p>0: OC1REF is not affected by ETRF input level</p> <p>1: OC1REF is cleared immediately when the ETRF input level is detected as high</p>   |
| 6:4       | OC1MD[2:0]  | <p>Output Compare 1 mode</p> <p>These bits are used to manage the output reference signal OC1REF, which determines the values of OC1 and OC1N, and is valid at high levels, while the active levels of OC1 and OC1N depend on the TIMx_CCEN.CC1P and TIMx_CCEN.CC1NP bits.</p> <p>000: Frozen. Comparison between TIMx_CCDAT1 register and counter TIMx_CNT has no effect on OC1REF signal.</p> <p>001: Set channel 1 to the active level on match. When TIMx_CCDAT1 = TIMx_CNT, OC1REF signal will be forced high.</p> <p>010: Set channel 1 as inactive level on match. When TIMx_CCDAT1 = TIMx_CNT, OC1REF signal will be forced low.</p> <p>011: Toggle. When TIMx_CCDAT1 = TIMx_CNT, OC1REF signal will be toggled.</p> <p>100: Force to inactive level. OC1REF signal is forced low.</p> <p>101: Force to active level. OC1REF signal is forced high.</p> <p>110: PWM mode 1 - In up-counting mode, if TIMx_CNT &lt; TIMx_CCDAT1, OC1REF signal of channel 1 is high, otherwise it is low. In down-counting mode, if TIMx_CNT &gt; TIMx_CCDAT1, OC1REF signal of channel 1 is low, otherwise it is high.</p> <p>111: PWM mode 2 - In up-counting mode, if TIMx_CNT &lt; TIMx_CCDAT1, OC1REF signal of channel 1 is low, otherwise it is high. In down-counting mode, if TIMx_CNT &gt; TIMx_CCDAT1, OC1REF signal of channel 1 is high, otherwise it is low.</p> <p><i>Note: In PWM mode 1 or PWM mode 2, the OC1REF level changes only when the comparison result changes or when the output compare mode is switched from frozen mode to PWM mode.</i></p> |

| Bit Field | Name        | Description   |
|-----------|-------------|---|
| 3         | OC1PEN      | Output Compare 1 preload enable<br>0: Disable preload function of TIMx_CC DAT1 register. Supports write operations to TIMx_CC DAT1 register at any time, and the written value is effective immediately.<br>1: Enable preload function of TIMx_CC DAT1 register. Only read and write operations to preload registers. When an update event occurs, the value of TIMx_CC DAT1 is loaded into the active register.<br><i>Note: Only when TIMx_CTRL1.ONEPM = 1(In one-pulse mode), PWM mode can be used without verifying the preload register, otherwise no other behavior can be predicted.</i>  |
| 2         | OC1FEN      | Output Compare 1 fast enable<br>This bit is used to speed up the response of the CC output to the trigger input event.<br>0: CC1 behaves normally depending on the counter and CC DAT1 values, even if the trigger is ON. The minimum delay for activating CC1 output when an edge occurs on the trigger input is 5 clock cycles.<br>1: An effective edge of the trigger input acts like a comparison match on CC1 output. Therefore, OC is set to the comparison level regardless of the comparison result. The delay time for sampling the trigger input and activating the CC1 output is reduced to 3 clock cycles.<br>OCxFEN only operates if the channel is configured in PWM1 or PWM2 mode. |
| 1: 0      | CC1SEL[1:0] | Capture/compare 1 selection<br>These bits are used to select the input/output and input mapping of the channel<br>00: CC1 channel is configured as output<br>01: CC1 channel is configured as input, IC1 is mapped on TI1<br>10: CC1 channel is configured as input, IC1 is mapped on TI2<br>11: CC1 channels are configured as inputs and IC1 is mapped to TRC. This mode is only active when the internal trigger input is selected by TIMx_SMCTRL.TSEL.<br><i>Note: CC1SEL is writable only when the channel is off (TIMx_CCEN.CCIEN = 0).</i>   |

## Input capture mode:



| Bit Field | Name        | Description               |
|-----------|-------------|---------------------------|
| 15:12     | IC2F[3:0]   | Input Capture 2 Filter    |
| 11:10     | IC2PSC[1:0] | Input Capture 2 Prescaler |

| Bit Field | Name        | Description  |
|-----------|-------------|--|
| 9:8       | CC2SEL[1:0] | <p>Capture/Compare 2 selection</p> <p>These bits are used to select the input/output and input mapping of the channel</p> <p>00: CC2 channel is configured as output</p> <p>01: CC2 channel is configured as input, IC2 is mapped on TI2</p> <p>10: CC2 channel is configured as input, IC2 is mapped on TI1</p> <p>11: CC2 channel is configured as input, IC2 is mapped on TRC. This mode is only active when the internal trigger input is selected by TIMx_SMCTRL.TSEL.</p> <p><i>Note: CC2SEL is writable only when the channel is off (TIMx_CCEN.CC2EN = 0).</i></p>   |
| 7:4       | IC1F[3:0]   | <p>Input Capture 1 filter</p> <p>These bits are used to define sampling frequency of TI1 input and the length of digital filter. The digital filter is an event counter that generates an output transition after N events are recorded.</p> <p>0000: No filter, sampling at f<sub>DTS</sub> frequency</p> <p>0001: f<sub>SAMPLING</sub> = f<sub>CK_INT</sub>, N = 2</p> <p>0010: f<sub>SAMPLING</sub> = f<sub>CK_INT</sub>, N = 4</p> <p>0011: f<sub>SAMPLING</sub> = f<sub>CK_INT</sub>, N = 8</p> <p>0100: f<sub>SAMPLING</sub> = f<sub>DTS</sub>/2, N = 6</p> <p>0101: f<sub>SAMPLING</sub> = f<sub>DTS</sub>/2, N = 8</p> <p>0110: f<sub>SAMPLING</sub> = f<sub>DTS</sub>/4, N = 6</p> <p>0111: f<sub>SAMPLING</sub> = f<sub>DTS</sub>/4, N = 8</p> <p>1000: f<sub>SAMPLING</sub> = f<sub>DTS</sub>/8, N = 6</p> <p>1001: f<sub>SAMPLING</sub> = f<sub>DTS</sub>/8, N = 8</p> <p>1010: f<sub>SAMPLING</sub> = f<sub>DTS</sub>/16, N = 5</p> <p>1011: f<sub>SAMPLING</sub> = f<sub>DTS</sub>/16, N = 6</p> <p>1100: f<sub>SAMPLING</sub> = f<sub>DTS</sub>/16, N = 8</p> <p>1101: f<sub>SAMPLING</sub> = f<sub>DTS</sub>/32, N = 5</p> <p>1110: f<sub>SAMPLING</sub> = f<sub>DTS</sub>/32, N = 6</p> <p>1111: f<sub>SAMPLING</sub> = f<sub>DTS</sub>/32, N = 8</p> |
| 3:2       | IC1PSC[1:0] | <p>Input Capture 1 prescaler</p> <p>These bits are used to select the ratio of the prescaler for IC1 (CC1 input).</p> <p>When TIMx_CCEN.CC1EN = 0, the prescaler will be reset.</p> <p>00: No prescaler, capture is done each time an edge is detected on the capture input</p> <p>01: Capture is done once every 2 events</p> <p>10: Capture is done once every 4 events</p> <p>11: Capture is done once every 8 events</p>   |
| 1:0       | CC1SEL[1:0] | <p>Capture/Compare 1 selection</p> <p>These bits are used to select the input/output and input mapping of the channel</p> <p>00: CC1 channel is configured as output</p> <p>01: CC1 channel is configured as input, IC1 is mapped on TI1</p> <p>10: CC1 channel is configured as input, IC1 is mapped on TI2</p> <p>11: CC1 channel is configured as input, IC1 is mapped to TRC. This mode is only active when the internal trigger input is selected by TIMx_SMCTRL.TSEL.</p>  |

| Bit Field | Name | Description   |
|-----------|------|---|
|           |      | <i>Note: CC1SEL is writable only when the channel is off (TIMx_CCEN.CC1EN = 0).</i> |

### 10.4.9 Capture/Compare Mode Register 2 (TIMx\_CCMOD2)

Offset address: 0x1C

Reset value: 0x0000

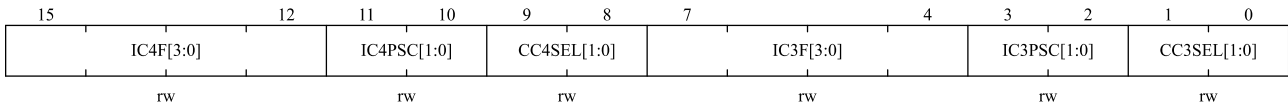
See the description of the CCMOD1 register above

Output comparison mode:

|        |            |    |        |        |             |   |        |            |   |        |        |             |   |
|--------|------------|----|--------|--------|-------------|---|--------|------------|---|--------|--------|-------------|---|
| 15     | 14         | 12 | 11     | 10     | 9           | 8 | 7      | 6          | 4 | 3      | 2      | 1           | 0 |
| OC4CEN | OC4MD[2:0] |    | OC4PEN | OC4FEN | CC4SEL[1:0] |   | OC3CEN | OC3MD[2:0] |   | OC3PEN | OC3FEN | CC3SEL[1:0] |   |
| rw     | rw         |    | rw     | rw     | rw          |   | rw     | rw         |   | rw     | rw     | rw          |   |

| Bit Field | Name        | Description   |
|-----------|-------------|---|
| 15        | OC4CEN      | Output compare 4 clear enable   |
| 14:12     | OC4MD[2:0]  | Output compare 4 mode   |
| 11        | OC4PEN      | Output compare 4 preload enable   |
| 10        | OC4FEN      | Output compare 4 fast enable  |
| 9:8       | CC4SEL[1:0] | Capture/Compare 4 selection<br>These bits are used to select the input/output and input mapping of the channel<br>00: CC4 channel is configured as output<br>01: CC4 channel is configured as input, IC4 is mapped on TI4<br>10: CC4 channel is configured as input, IC4 is mapped on TI3<br>11: CC4 channel is configured as input, IC4 is mapped on TRC. This mode is only active when the internal trigger input is selected by TIMx_SMCTRL.TSEL.<br><i>Note: CC4SEL is writable only when the channel is off (TIMx_CCEN.CC4EN = 0).</i> |
| 7         | OC3CEN      | Output compare 3 clear enable   |
| 6:4       | OC3MD[2:0]  | Output compare 3 mode   |
| 3         | OC3PEN      | Output compare 3 preload enable   |
| 2         | OC3FEN      | Output compare 3 fast enable  |
| 1:0       | CC3SEL[1:0] | Capture/Compare 3 selection<br>These bits are used to select the input/output and input mapping of the channel<br>00: CC3 channel is configured as output<br>01: CC3 channel is configured as input, IC3 is mapped to TI3<br>10: CC3 channel is configured as input, IC3 is mapped on TI4<br>11: CC3 channel is configured as input, IC3 is mapped to TRC. This mode is only active when the internal trigger input is selected by TIMx_SMCTRL.TSEL.<br><i>Note: CC3SEL is writable only when the channel is off (TIMx_CCEN.CC3EN = 0).</i> |

Input capture mode:

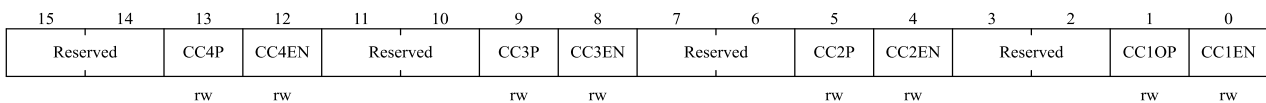


| Bit Field | Name        | Description   |
|-----------|-------------|---|
| 15:12     | IC4F[3:0]   | Input Capture 4 filter  |
| 11:10     | IC4PSC[1:0] | Input Capture 4 Prescaler   |
| 9:8       | CC4SEL[1:0] | Capture/Compare 4 selection<br>These bits are used to select the input/output and input mapping of the channel<br>00: CC4 channel is configured as output<br>01: CC4 channel is configured as input, IC4 is mapped on TI4<br>10: CC4 channel is configured as input, IC4 is mapped on TI3<br>11: CC4 channel is configured as input, IC4 is mapped on TRC. This mode is only active when the internal trigger input is selected by TIMx_SMCTRL.TSEL.<br><i>Note: CC4SEL is writable only when the channel is off (TIMx_CCEN.CC4EN = 0).</i> |
| 7:4       | IC3F[3:0]   | Input Capture 3 filter  |
| 3:2       | IC3PSC[1:0] | Input Capture 3 Prescaler   |
| 1:0       | CC3SEL[1:0] | Capture/compare 3 selection<br>These bits are used to select the input/output and input mapping of the channel<br>00: CC3 channel is configured as output<br>01: CC3 channel is configured as input, IC3 is mapped to TI3<br>10: CC3 channel is configured as input, IC3 is mapped on TI4<br>11: CC3 channel is configured as input, IC3 is mapped to TRC. This mode is only active when the internal trigger input is selected by TIMx_SMCTRL.TSEL.<br><i>Note: CC3SEL is writable only when the channel is off (TIMx_CCEN.CC3EN = 0).</i> |

### 10.4.10 Capture/Compare Enable Registers (TIMx\_CCEN)

Offset address: 0x20

Reset value: 0x0000



| Bit Field | Name     | Description  |
|-----------|----------|--|
| 15:14     | Reserved | Reserved, the reset value must be maintained.                        |
| 13        | CC4P     | Capture/Compare 4 output polarity<br>See TIMx_CCEN.CC1P description. |
| 12        | CC4EN    | Capture/Compare 4 output enable<br>See TIMx_CCEN.CC1EN description.  |
| 11:10     | Reserved | Reserved, the reset value must be maintained                         |
| 9         | CC3P     | Capture/Compare 3 output polarity                                    |



| Bit Field | Name     | Description  |
|-----------|----------|--|
|           |          | See TIMx_CCEN.CC1P description.  |
| 8         | CC3EN    | Capture/Compare 3 output enable<br>See TIMx_CCEN.CC1EN description.  |
| 7:6       | Reserved | Reserved, the reset value must be maintained   |
| 5         | CC2P     | Capture/Compare 2 output polarity<br>See TIMx_CCEN.CC1P description.   |
| 4         | CC2EN    | Capture/Compare 2 output enable<br>See TIMx_CCEN.CC1EN description.  |
| 3:2       | Reserved | Reserved, the reset value must be maintained   |
| 1         | CC1P     | Capture/Compare 1 output polarity<br>When the corresponding channel of CC1 is in output mode:<br>0: OC1 active high<br>1: OC1 active low<br>When the corresponding channel of CC1 is in input mode:<br>At this time, this bit is used to select whether IC1 or the inverse signal of IC1 is used as the trigger or capture signal.<br>0: non-inverted: Capture action occurs when IC1 generates a rising edge. When used as external trigger, IC1 is non-inverted.<br>1: inverted: Capture action occurs when IC1 generates a falling edge. When used as external trigger, IC1 is inverted.<br><i>Note: If TIMx_BKDT.LCKCFG = 3 or 2, these bits cannot be modified.</i> |
| 0         | CC1EN    | Capture/Compare 1 output enable<br>When the corresponding channel of CC1 is in output mode:<br>0: Disable - Disable output OC1 signal.<br>1: Enable - Enable output OC1 signal.<br>When the corresponding channel of CC1 is in input mode:<br>At this time, this bit is used to disable/enable the capture function.<br>0: Disable capture<br>1: Enable capture  |

**Table 10-4 Output Control Bits of Standard OCx Channel**

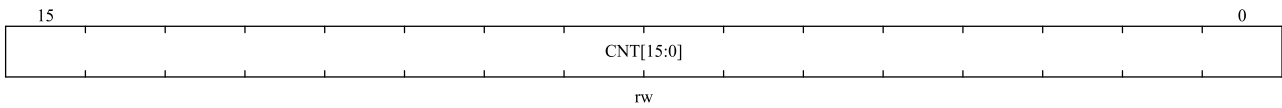
| CCxEN | OCx Output Status       |
|-------|-------------------------|
| 0     | Disable output (OCx=0)  |
| 1     | OCx = OCxREF + polarity |

*Note: The state of external I/O pins connected to standard OCx channels depends on the OCx channel state and GPIO and AFIO registers.*

### 10.4.11 Counters (TIMx\_CNT)

Offset address: 0x24

Reset value: 0x0000

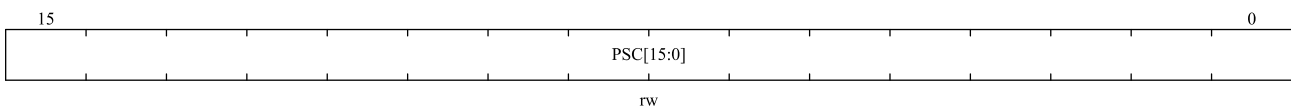


| Bit Field | Name      | Description   |
|-----------|-----------|---------------|
| 15:0      | CNT[15:0] | Counter value |

### 10.4.12 Prescaler (TIMx\_PSC)

Offset address: 0x28

Reset value: 0x0000

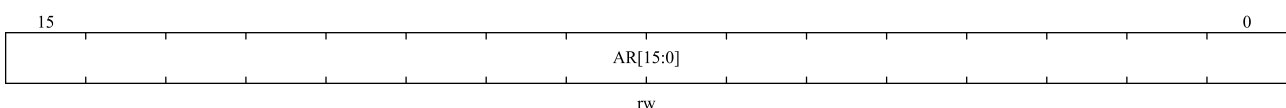


| Bit Field | Name      | Description  |
|-----------|-----------|--|
| 15:0      | PSC[15:0] | Prescaler value<br>Counter clock $f_{CK\_CNT} = f_{CK\_PSC} / (PSC [15:0] + 1)$ .<br>Each time an update event occurs, the PSC value is loaded into the active prescaler register. |

### 10.4.13 Auto-reload Register (TIMx\_AR)

Offset address: 0x2C

Reset values: 0xFFFF

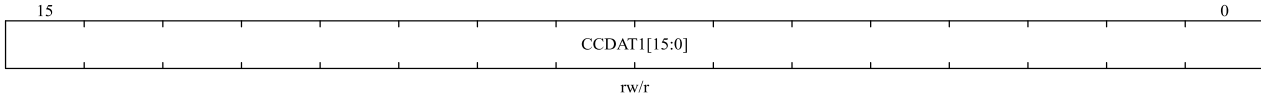


| Bit Field | Name     | Description  |
|-----------|----------|--|
| 15:0      | AR[15:0] | Auto-reload value<br>These bits define the value that will be loaded into the actual auto-reload register.<br>See Section 9.3.1 for more details.<br>When the TIMx_AR.AR [15:0] value is null, the counter does not operate. |

### 10.4.14 Capture/Compare Register 1 (TIMx\_CC1)

Offset address: 0x34

Reset value: 0x0000



| Bit Field | Name         | Description  |
|-----------|--------------|--|
| 15:0      | CCDAT1[15:0] | <p>Capture/Compare 1 value</p> <ul style="list-style-type: none"> <li>CC1 channel is configured as output:<br/>CCDAT1 contains the value to be compared to the counter TIMx_CNT, signaling on the OC1 output.<br/>If the preload feature is not selected in TIMx_CCMOD1.OC1PEN bit, the written value is immediately transferred to the active register. Otherwise, this preloaded value is transferred to the active register only when an update event occurs.</li> <li>CC1 channel is configured as input:<br/>CCDAT1 contains the counter value transferred by the last input capture 1 event (IC1).<br/>When configured as input mode, register CCDAT1 is only readable.<br/>When configured as output mode, register CCDAT1 is readable and writable.</li> </ul> |

**10.4.15 Capture/Compare Register 2 (TIMx\_CCDAT2)**

Offset address: 0x38

Reset value: 0x0000

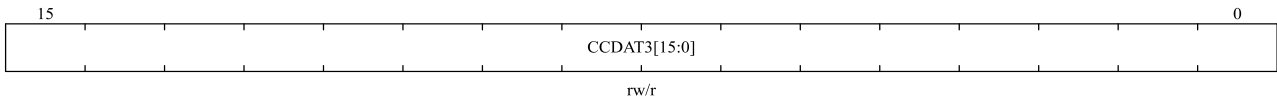


| Bit Field | Name         | Description   |
|-----------|--------------|---|
| 15:0      | CCDAT2[15:0] | <p>Capture/Compare 2 values</p> <ul style="list-style-type: none"> <li>CC2 channel is configured as output:<br/>CCDAT2 contains the value to be compared to the counter TIMx_CNT, signaling on the OC2 output.<br/>If the preload feature is not selected in TIMx_CCMOD1.OC2PEN bit, the written value is immediately transferred to the active register. Otherwise, this preloaded value is transferred to the active register only when an update event occurs.</li> <li>CC2 channel is configured as input:<br/>CCDAT2 contains the counter value transferred by the last input capture 2 event (IC2).<br/>When configured as input mode, register CCDAT2 is only readable.<br/>When configured as output mode, register CCDAT2 is readable and writable.</li> </ul> |

**10.4.16 Capture/Compare Register 3 (TIMx\_CCDAT3)**

Offset address: 0x3C

Reset value: 0x0000

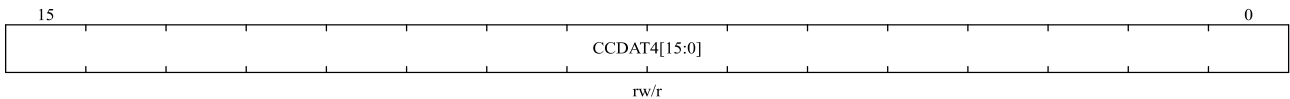


| Bit Field | Name         | Description  |
|-----------|--------------|--|
| 15:0      | CCDAT3[15:0] | <p>Capture/Compare 3 value</p> <ul style="list-style-type: none"> <li>CC3 channel is configured as output:<br/>CCDAT3 contains the value to be compared to the counter TIMx_CNT, signaling on the OC3 output.<br/>If the preload feature is not selected in TIMx_CCMOD2.OC3PEN bit, the written value is immediately transferred to the active register. Otherwise, this preloaded value is transferred to the active register only when an update event occurs.</li> <li>CC3 channel is configured as input:<br/>CCDAT3 contains the counter value transferred by the last input capture 3 event (IC3).<br/>When configured as input mode, register CCDAT3 is only readable.<br/>When configured as output mode, register CCDAT3 is readable and writable.</li> </ul> |

**10.4.17 Capture/Compare Register 4 (TIMx\_CCDAT4)**

Offset address: 0x40

Reset value: 0x0000

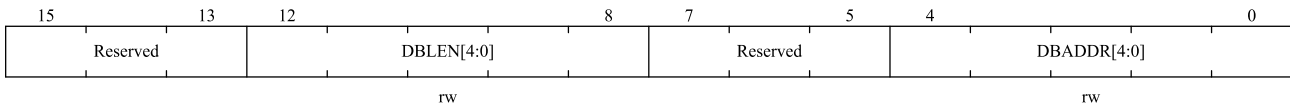


| Bit Field | Name         | Description  |
|-----------|--------------|--|
| 15:0      | CCDAT4[15:0] | <p>Capture/Compare 4 value</p> <ul style="list-style-type: none"> <li>CC4 channel is configured as output:<br/>CCDAT4 contains the value to be compared to the counter TIMx_CNT, signaling on the OC4 output.<br/>If the preload feature is not selected in TIMx_CCMOD2.OC4PEN bit, the written value is immediately transferred to the active register. Otherwise, this preloaded value is transferred to the active register only when an update event occurs.</li> <li>CC4 channel is configured as input:<br/>CCDAT4 contains the counter value transferred by the last input capture 4 event (IC4).<br/>When configured as input mode, register CCDAT4 is only readable.<br/>When configured as output mode, register CCDAT4 is readable and writable.</li> </ul> |

### 10.4.18 DMA Control Register (TIMx\_DCTRL)

Offset address: 0x48

Reset value: 0x0000

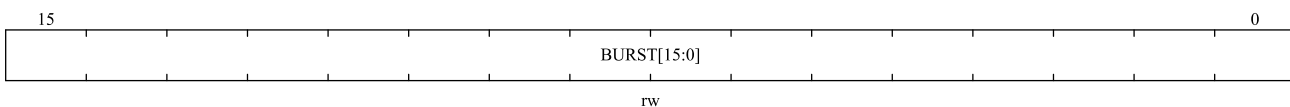


| Bit Field | Name        | Description   |
|-----------|-------------|---|
| 15:13     | Reserved    | Reserved, the reset value must be maintained  |
| 12:8      | DBLEN[4:0]  | <p>DMA Burst Length</p> <p>This bit field defines the number DMA will accesses (write/read) TIMx_DADDR register.</p> <p>00000: 1 time transfer</p> <p>00001: 2 times transfers</p> <p>00010: 3 times transfers</p> <p>...</p> <p>10001: 18 times transfers</p>  |
| 7:5       | Reserved    | Reserved, the reset value must be maintained.   |
| 4:0       | DBADDR[4:0] | <p>DMA Base Address</p> <p>This bit field defines the first address where the DMA accesses the TIMx_DADDR register. When access is done through the TIMx_DADDR first time, this bit-field specifies the address you just access. And then the second access to the TIMx_DADDR, you will access the address of "DMA Base Address + 4"</p> <p>00000: TIMx_CTRL1,</p> <p>00001: TIMx_CTRL2,</p> <p>00010: TIMx_SMCTRL,</p> <p>...</p> <p>01011: TIMx_AR,</p> <p>01100: Reserved,</p> <p>01101: TIMx_CC DAT1,</p> <p>.....</p> <p>10000: TIMx_CC DAT4,</p> <p>10001: Reserved,</p> <p>10010: TIMx_DCTRL</p> |

### 10.4.19 DMA Transfer Buffer Register (TIMx\_DADDR)

Offset address: 0x4C

Reset value: 0x0000



| Bit Field | Name        | Description   |
|-----------|-------------|---|
| 15:0      | BURST[15:0] | <p>DMA access buffer.</p> <p>When a read or write operation is assigned to this register, the register located at the address range (DMA base address + DMA burst length × 4) will be accessed.</p> <p>DMA base address = The address of TIM_CTRL1 + TIMx_DCTRL.DBADDR * 4;<br/>           DMA burst len = TIMx_DCTRL.DBLEN + 1.</p> <p>Example:<br/>           If TIMx_DCTRL.DBLEN = 0x3(4 transfers), TIMx_DCTRL.DBADDR = 0xD (TIMx_CC DAT1), DMA data length = half word, DMA memory address = buffer address in SRAM, DMA peripheral address = TIMx_DADDR address.</p> <p>When an event occurs, TIMx will send requests to the DMA, and transfer data 4 times.</p> <p>For the first time, DMA access to the TIMx_DADDR register will be mapped to access TIMx_CC DAT1 register;</p> <p>For the second time, DMA access to the TIMx_DADDR register will be mapped to access TIMx_CC DAT2 register;</p> <p>... ..</p> <p>For the fourth time, DMA access to the TIMx_DADDR register will be mapped to access TIMx_CC DAT4 register;</p> |

## 11 Basic Timer (TIM6)

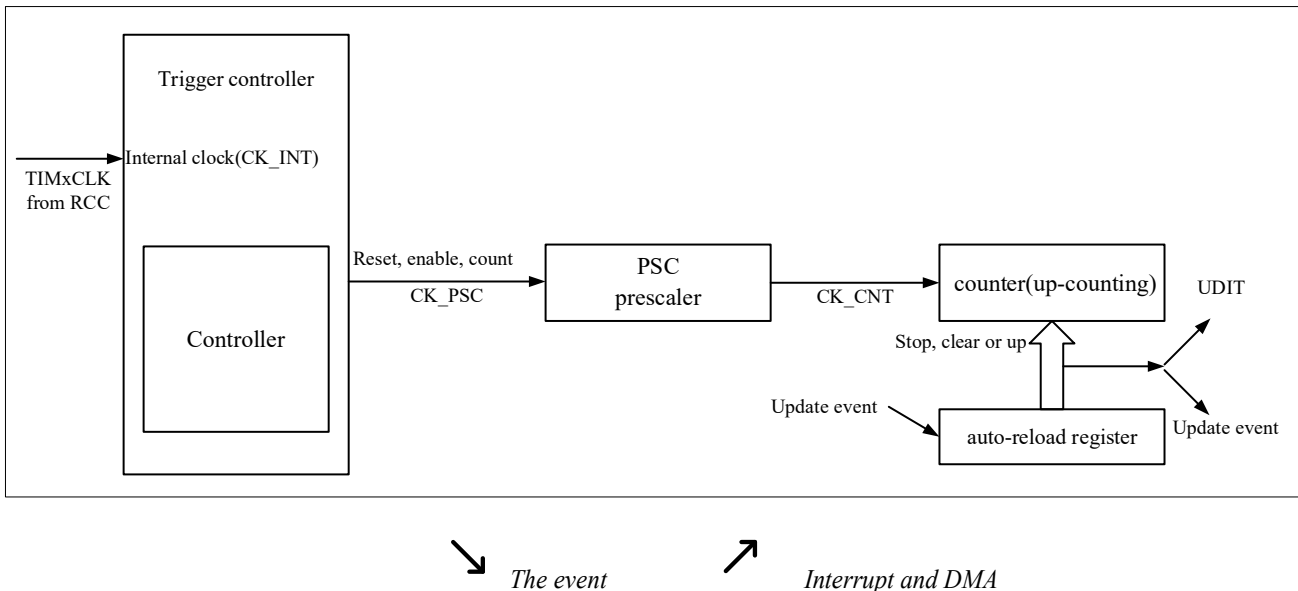
### 11.1 Basic Timer Introduction

The basic timer contains a 16-bit auto-reloading counter.

### 11.2 Main Features of Basic Timer

- 16-bit auto-reload up-counting counters.
- 16-bit programmable prescaler. (The prescaler factor can be configured with any value between 1 and 65536)
- Event that generates the interrupt/DMA is as follows:
  - Update event

**Figure 11-1 Block Diagram of TIMx (x = 6)**



### 11.3 Basic Timers Description

#### 11.3.1 Time-base Unit

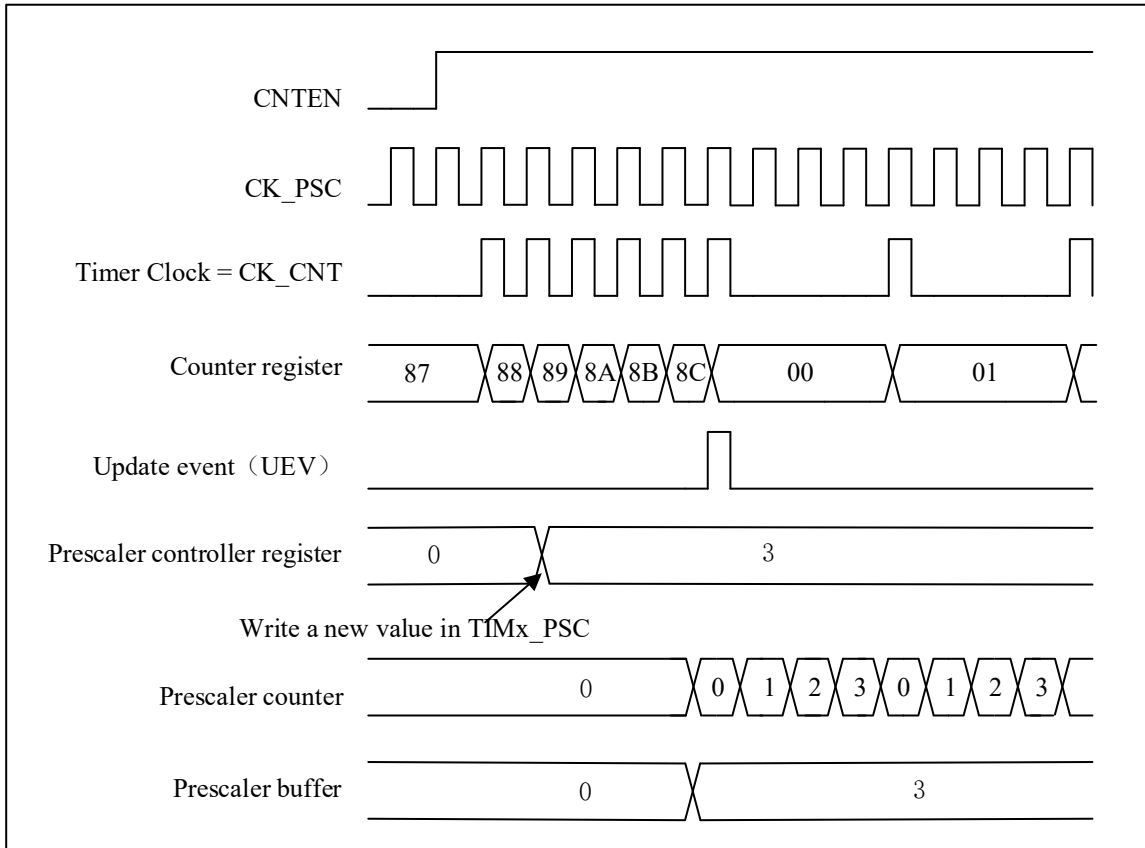
The time-base unit mainly includes: prescaler, counter and auto-reload. When the time base unit is operating, user can read and write the corresponding registers (TIMx\_PSC, TIMx\_CNT and TIMx\_AR) at any time by the software.

Depending on the setting of the auto-reload preload enable bit (TIMx\_CTRL1.ARPEN), the value of the preload register is transferred to the shadow register immediately or at each update event UEV. An update event is generated when the counter reaches the overflow condition and it can be generated by software when TIMx\_CTRL1.UPDIS=0. The counter CK\_CNT is valid only when the TIMx\_CTRL1.CNTEN bit is set. The counter starts counting one clock cycle after the TIMx\_CTRL1.CNTEN bit is set.

**11.3.1.1 Prescaler description**

The TIMx\_PSC register consists of a 16-bit counter that can be used to divide the counter clock frequency by any factor between 1 and 65536. Because this controller has a buffer, it can be dynamically changed at runtime. The new prescaler value will only be adopted during the next update event.

**Figure 11-2 Counter Timing Diagram with Prescaler Division Change from 1 to 4**



**11.3.2 Counter Mode**

**11.3.2.1 Up-counting mode**

In up-counting mode, the counter will count from 0 to the value of the register TIMx\_AR, then it resets to 0. And a counter overflow event is generated.

If the TIMx\_CTRL1.UPRS bit (selecting update request) and the TIMx\_EVTGEN.UDGN bit are set, an update event (UEV) will generate, and TIMx\_STS.UDITF will not be set by hardware. Therefore, no update interrupts or update DMA requests are generated. This setting is used in scenarios where you want to clear the counter but do not want to generate an update interrupt.

Depending on the configuration of TIMx\_CTRL1.UPRS, When an update event occurs, all registers are updated and the TIMx\_STS.UDITF is set:

- Update auto-reload shadow registers with preload value(TIMx\_AR), when TIMx\_CTRL1.ARPEN = 1.
- The prescaler shadow register is reloaded with the preload value(TIMx\_PSC)



To avoid updating the shadow registers when new values are written to the preload registers, you can disable the update by setting TIMx\_CTRL1.UPDIS=1.

When an update event occurs, the counter will still be cleared and the prescaler counter will also be set to 0 (but the prescaler value will remain unchanged).

The figures below show some examples of the counter behavior and the update flags for different division factors in the up-counting mode.

**Figure 11-3 Timing Diagram of Up-counting. The Internal Clock Divider Factor = 2/N**

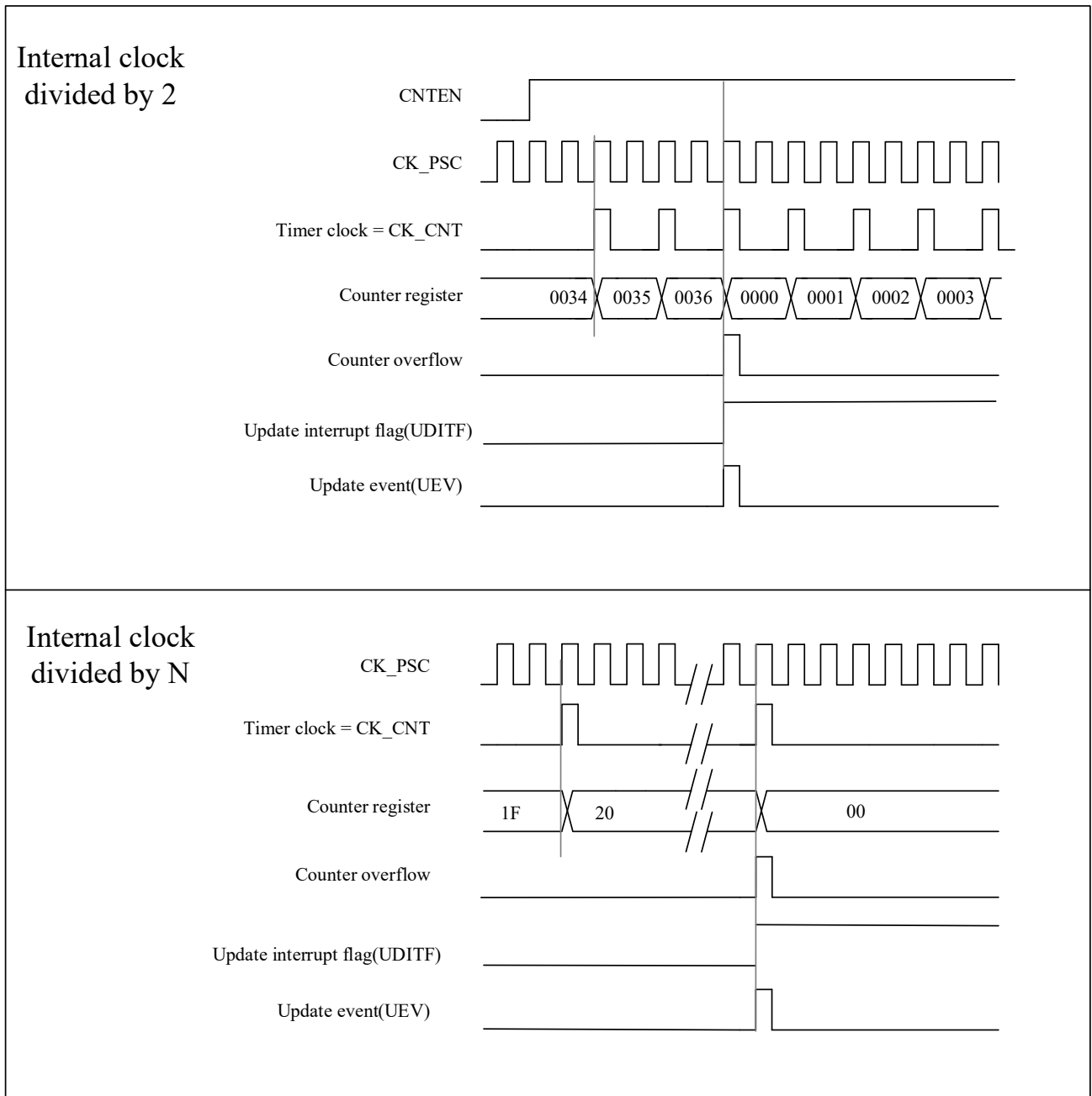
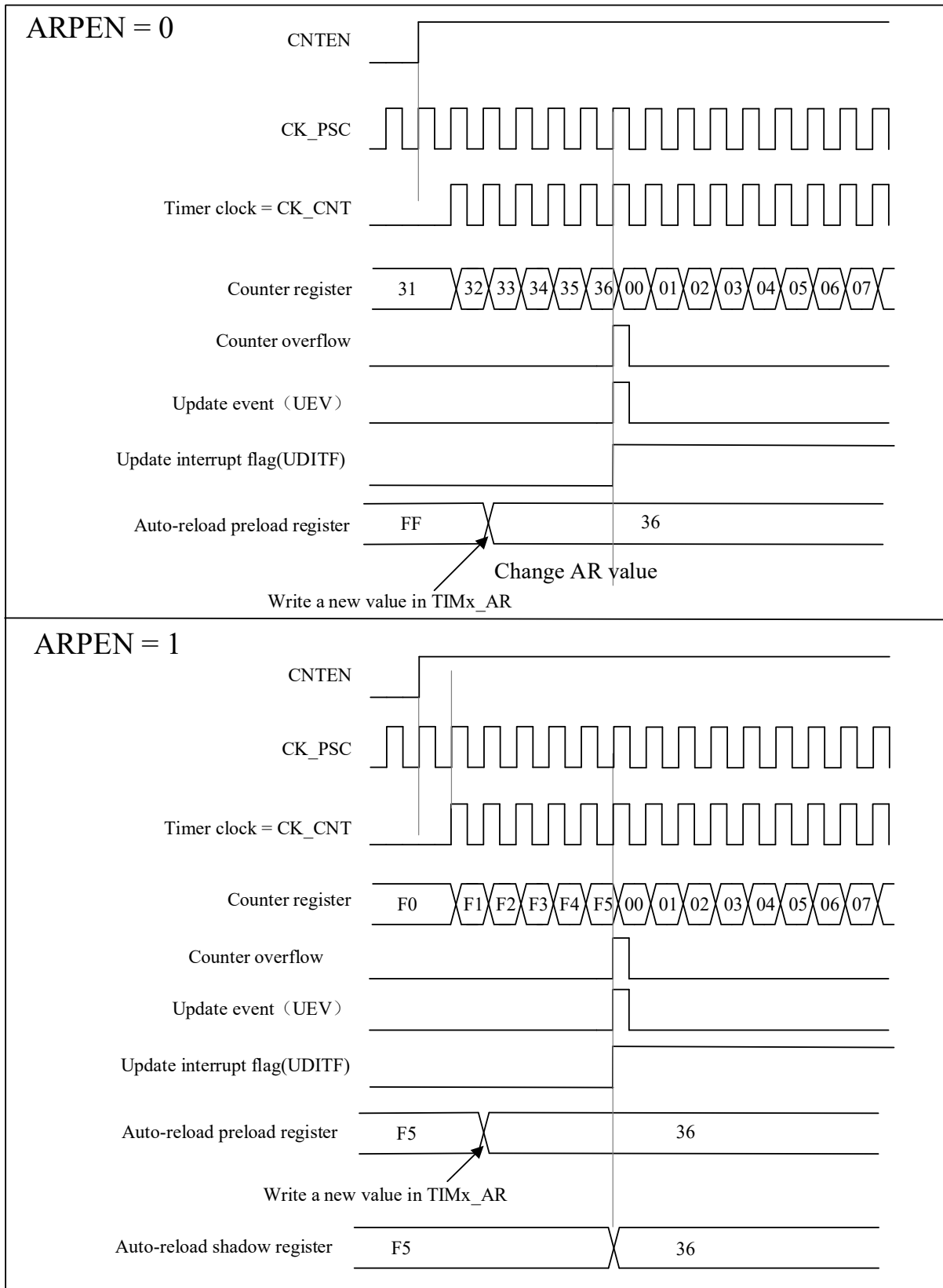


Figure 11-4 Timing Diagram of The Up-counting, Update Event When ARPEN= 0/1



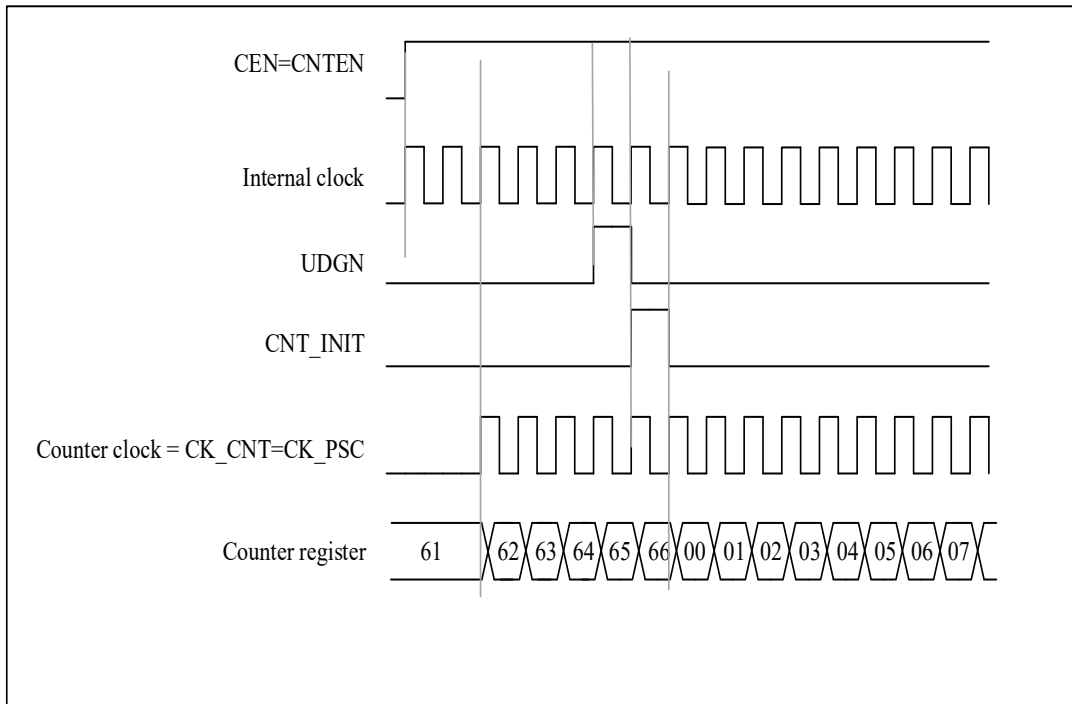
### 11.3.3 Clock Selection

- The internal clock of timer: CK\_INT

#### 11.3.3.1 Internal clock source (CK\_INT)

Assuming the TIMx\_CTRL1.CNTEN bit is written as '1' by software, the clock source of the prescaler is provided by the internal clock CK\_INT.

**Figure 11-5 Control Circuit in Normal Mode, Internal Clock Divided by 1**



### 11.3.4 Debug Mode

When the microcontroller is in debug mode (the Cortex<sup>®</sup>-M0 core halted), depending on the DBG\_CTRL.TIMx\_STOP configuration in the PWR module, the TIMx counter can either continue to operate normally or stop. For more details, refer to 3.3.2.

## 11.4 TIMx Register Description(x=6)

For abbreviations used in registers, refer to section 1.1

These peripheral registers can be operated as half word (16-bits) or one word (32-bits).

### 11.4.1 Register Overview

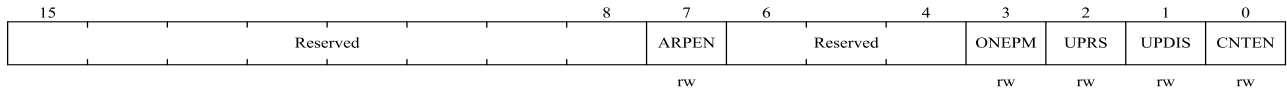
Table 11-1 Register Overview

| Offset | Register    | 31       | 30 | 29 | 28 | 27 | 26 | 25 | 24 | 23 | 22 | 21 | 20 | 19 | 18 | 17 | 16        | 15 | 14 | 13 | 12 | 11 | 10 | 9 | 8     | 7        | 6 | 5 | 4     | 3     | 2    | 1     | 0     |   |   |   |   |   |   |   |   |   |   |   |   |   |   |   |   |
|--------|-------------|----------|----|----|----|----|----|----|----|----|----|----|----|----|----|----|-----------|----|----|----|----|----|----|---|-------|----------|---|---|-------|-------|------|-------|-------|---|---|---|---|---|---|---|---|---|---|---|---|---|---|---|---|
| 000h   | TIMx_CTRL1  | Reserved |    |    |    |    |    |    |    |    |    |    |    |    |    |    |           |    |    |    |    |    |    |   | ARPEN | Reserved |   |   |       | ONEPM | UPRS | UPDIS | CNTEN |   |   |   |   |   |   |   |   |   |   |   |   |   |   |   |   |
|        | Reset Value |          |    |    |    |    |    |    |    |    |    |    |    |    |    |    |           |    |    |    |    |    |    |   | 0     |          |   |   |       | 0     | 0    | 0     | 0     |   |   |   |   |   |   |   |   |   |   |   |   |   |   |   |   |
| 004h   | Reserved    |          |    |    |    |    |    |    |    |    |    |    |    |    |    |    |           |    |    |    |    |    |    |   |       |          |   |   |       |       |      |       |       |   |   |   |   |   |   |   |   |   |   |   |   |   |   |   |   |
| 008h   | Reserved    |          |    |    |    |    |    |    |    |    |    |    |    |    |    |    |           |    |    |    |    |    |    |   |       |          |   |   |       |       |      |       |       |   |   |   |   |   |   |   |   |   |   |   |   |   |   |   |   |
| 00Ch   | TIMx_DINTEN | Reserved |    |    |    |    |    |    |    |    |    |    |    |    |    |    |           |    |    |    |    |    |    |   | UDEN  | Reserved |   |   |       | UIEN  |      |       |       |   |   |   |   |   |   |   |   |   |   |   |   |   |   |   |   |
|        | Reset Value |          |    |    |    |    |    |    |    |    |    |    |    |    |    |    |           |    |    |    |    |    |    |   | 0     |          |   |   |       | 0     |      |       |       |   |   |   |   |   |   |   |   |   |   |   |   |   |   |   |   |
| 010h   | TIMx_STS    | Reserved |    |    |    |    |    |    |    |    |    |    |    |    |    |    |           |    |    |    |    |    |    |   |       |          |   |   | UDITF |       |      |       |       |   |   |   |   |   |   |   |   |   |   |   |   |   |   |   |   |
|        | Reset Value |          |    |    |    |    |    |    |    |    |    |    |    |    |    |    |           |    |    |    |    |    |    |   |       |          |   |   | 0     |       |      |       |       |   |   |   |   |   |   |   |   |   |   |   |   |   |   |   |   |
| 014h   | TIMx_EVTGEN | Reserved |    |    |    |    |    |    |    |    |    |    |    |    |    |    |           |    |    |    |    |    |    |   |       |          |   |   | UDGN  |       |      |       |       |   |   |   |   |   |   |   |   |   |   |   |   |   |   |   |   |
|        | Reset Value |          |    |    |    |    |    |    |    |    |    |    |    |    |    |    |           |    |    |    |    |    |    |   |       |          |   |   | 0     |       |      |       |       |   |   |   |   |   |   |   |   |   |   |   |   |   |   |   |   |
| 018h   | Reserved    |          |    |    |    |    |    |    |    |    |    |    |    |    |    |    |           |    |    |    |    |    |    |   |       |          |   |   |       |       |      |       |       |   |   |   |   |   |   |   |   |   |   |   |   |   |   |   |   |
| 01Ch   | Reserved    |          |    |    |    |    |    |    |    |    |    |    |    |    |    |    |           |    |    |    |    |    |    |   |       |          |   |   |       |       |      |       |       |   |   |   |   |   |   |   |   |   |   |   |   |   |   |   |   |
| 020h   | Reserved    |          |    |    |    |    |    |    |    |    |    |    |    |    |    |    |           |    |    |    |    |    |    |   |       |          |   |   |       |       |      |       |       |   |   |   |   |   |   |   |   |   |   |   |   |   |   |   |   |
| 024h   | TIMx_CNT    | Reserved |    |    |    |    |    |    |    |    |    |    |    |    |    |    | CNT[15:0] |    |    |    |    |    |    |   |       |          |   |   |       |       |      |       |       |   |   |   |   |   |   |   |   |   |   |   |   |   |   |   |   |
|        | Reset Value |          |    |    |    |    |    |    |    |    |    |    |    |    |    |    | 0         | 0  | 0  | 0  | 0  | 0  | 0  | 0 | 0     | 0        | 0 | 0 | 0     | 0     | 0    | 0     | 0     | 0 | 0 | 0 | 0 | 0 | 0 | 0 | 0 | 0 | 0 | 0 | 0 | 0 | 0 |   |   |
| 028h   | TIMx_PSC    | Reserved |    |    |    |    |    |    |    |    |    |    |    |    |    |    | PSC[15:0] |    |    |    |    |    |    |   |       |          |   |   |       |       |      |       |       |   |   |   |   |   |   |   |   |   |   |   |   |   |   |   |   |
|        | Reset Value |          |    |    |    |    |    |    |    |    |    |    |    |    |    |    | 0         | 0  | 0  | 0  | 0  | 0  | 0  | 0 | 0     | 0        | 0 | 0 | 0     | 0     | 0    | 0     | 0     | 0 | 0 | 0 | 0 | 0 | 0 | 0 | 0 | 0 | 0 | 0 | 0 | 0 | 0 | 0 | 0 |
| 02Ch   | TIMx_AR     | Reserved |    |    |    |    |    |    |    |    |    |    |    |    |    |    | AR[15:0]  |    |    |    |    |    |    |   |       |          |   |   |       |       |      |       |       |   |   |   |   |   |   |   |   |   |   |   |   |   |   |   |   |
|        | Reset Value |          |    |    |    |    |    |    |    |    |    |    |    |    |    |    | 1         | 1  | 1  | 1  | 1  | 1  | 1  | 1 | 1     | 1        | 1 | 1 | 1     | 1     | 1    | 1     | 1     | 1 | 1 | 1 | 1 | 1 | 1 | 1 | 1 | 1 | 1 | 1 | 1 | 1 | 1 | 1 | 1 |

### 11.4.2 Control Register 1 (TIMx\_CTRL1)

Offset address: 0x00

Reset value: 0x0000

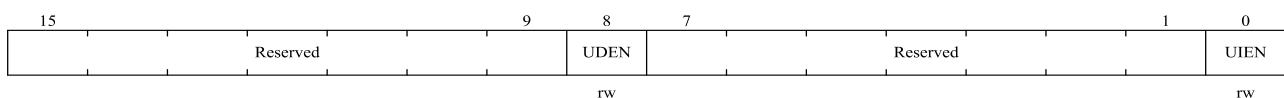


| Bit Field | Name     | Description  |
|-----------|----------|--|
| 15:8      | Reserved | Reserved, the reset value must be maintained   |
| 7         | ARPEN    | ARPEN: Auto-reload preload enable<br>0: Shadow register disable for TIMx_AR register<br>1: Shadow register enable for TIMx_AR register   |
| 6:4       | Reserved | Reserved, the reset value must be maintained   |
| 3         | ONEPM    | One-pulse mode<br>0: Disable one-pulse mode, the counter counts are not affected when an update event occurs.<br>1: Enable one-pulse mode, the counter stops counting when the next update event occurs (clearing TIMx_CTRL1.CNTEN bit)  |
| 2         | UPRS     | Update request source<br>This bit is used to select the UEV event sources by software.<br>0: If update interrupt or DMA request is enabled, any of the following events will generate an update interrupt or DMA request:<br>Counter overflow<br>The TIMx_EVTGEN.UDGN bit is set<br>1: If update interrupt or DMA request is enabled, only counter overflow will generate update interrupt or DMA request  |
| 1         | UPDIS    | Update disable<br>This bit is used to enable/disable the Update event (UEV) events generation by software.<br>0: Enable UEV. UEV will be generated if one of following condition been fulfilled:<br>Counter overflow<br>The TIMx_EVTGEN.UDGN bit is set<br>Shadow registers will update with preload value.<br>1: UEV disabled. No update event is generated, and the shadow registers (AR, PSC) keep their values. If the TIMx_EVTGEN.UDGN bit is set, the counter and prescaler are reinitialized. |
| 0         | CNTEN    | Counter Enable<br>0: Disable counter<br>1: Enable counter  |

### 11.4.3 DMA/Interrupt Enable Registers (TIMx\_DINTEN)

Offset address: 0x0C

Reset value: 0x0000

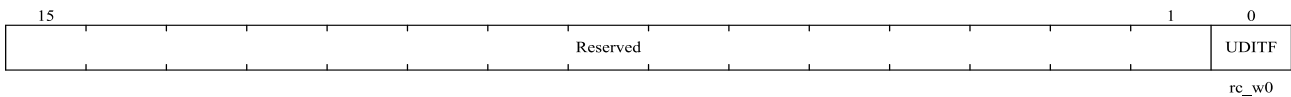


| Bit Field | Name     | Description  |
|-----------|----------|--|
| 15:9      | Reserved | Reserved, the reset value must be maintained   |
| 8         | UDEN     | Update DMA Request enable<br>0: Disable update DMA request<br>1: Enable update DMA request |
| 7:1       | Reserved | Reserved, the reset value must be maintained   |
| 0         | UIEN     | Update interrupt enable<br>0: Disable update interrupt<br>1: Enables update interrupt      |

#### 11.4.4 Status Registers (TIMx\_STS)

Offset address: 0x10

Reset value: 0x0000

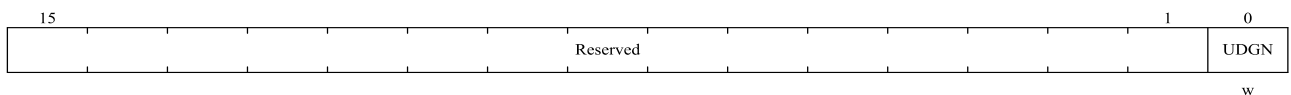


| Bit Field | Name     | Description  |
|-----------|----------|--|
| 15:1      | Reserved | Reserved, the reset value must be maintained   |
| 0         | UDITF    | Update interrupt flag<br>This bit is set by hardware when an update event occurs under the following conditions:<br>When TIMx_CTRL1.UPDIS = 0, and counter value overflow.<br>When TIMx_CTRL1.UPRS = 0, TIMx_CTRL1.UPDIS = 0, and set the TIMx_EVTGEN.UDGN bit by software to reinitialize the CNT.<br>This bit is cleared by software.<br>0: No update event occurred<br>1: Update interrupt occurred |

#### 11.4.5 Event Generation Registers (TIMx\_EVTGEN)

Offset address: 0x14

Reset values: 0 x0000



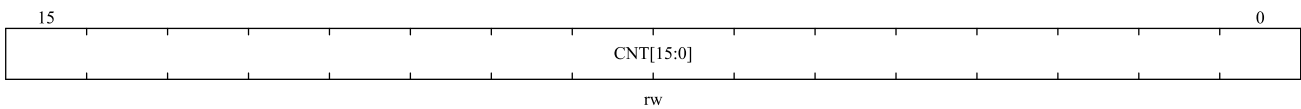
| Bit Field | Name     | Description                                   |
|-----------|----------|---|
| 15: 1     | Reserved | Reserved, the reset value must be maintained. |

| Bit Field | Name | Description  |
|-----------|------|--|
| 0         | UDGN | UDGN: Update generation<br>Software can set this bit to update configuration register value and hardware will clear it automatically.<br>0: No effect.<br>1: Timer counter will restart and all shadow register will be updated. It will restart prescaler counter also. |

### 11.4.6 Counters (TIMx\_CNT)

Offset address: 0x24

Reset value: 0x0000

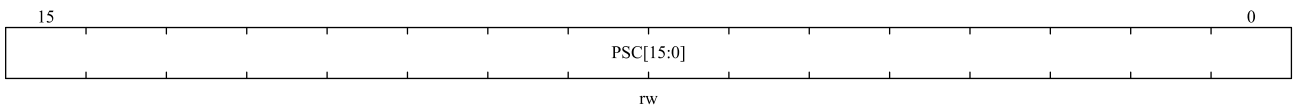


| Bit Field | Name      | Description   |
|-----------|-----------|---------------|
| 15:0      | CNT[15:0] | Counter value |

### 11.4.7 Prescaler (TIMx\_PSC)

Offset address: 0x28

Reset value: 0x0000

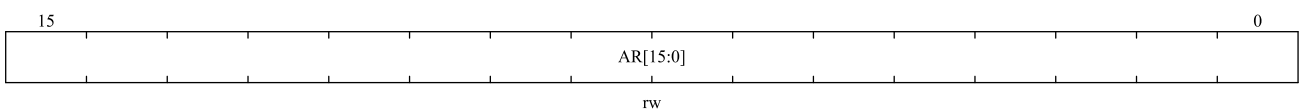


| Bit Field | Name      | Description   |
|-----------|-----------|---|
| 15:0      | PSC[15:0] | Prescaler value<br>PSC register value will be updated to prescaler register at update event. Counter clock frequency is input clock frequency divide PSC + 1. |

### 11.4.8 Automatic Reload Register (TIMx\_AR)

Offset address: 0x2C

Reset values: 0xFFFF



| Bit Field | Name     | Description   |
|-----------|----------|---|
| 15:0      | AR[15:0] | Auto-reload value<br>These bits define the value that will be loaded into the actual auto-reload register.<br>See 11.3.1 for more details.<br>When the TIMx_AR.AR [15:0] value is null, the counter does not operate. |



## 12 Low Power Timer (LPTIM)

### 12.1 Introduction

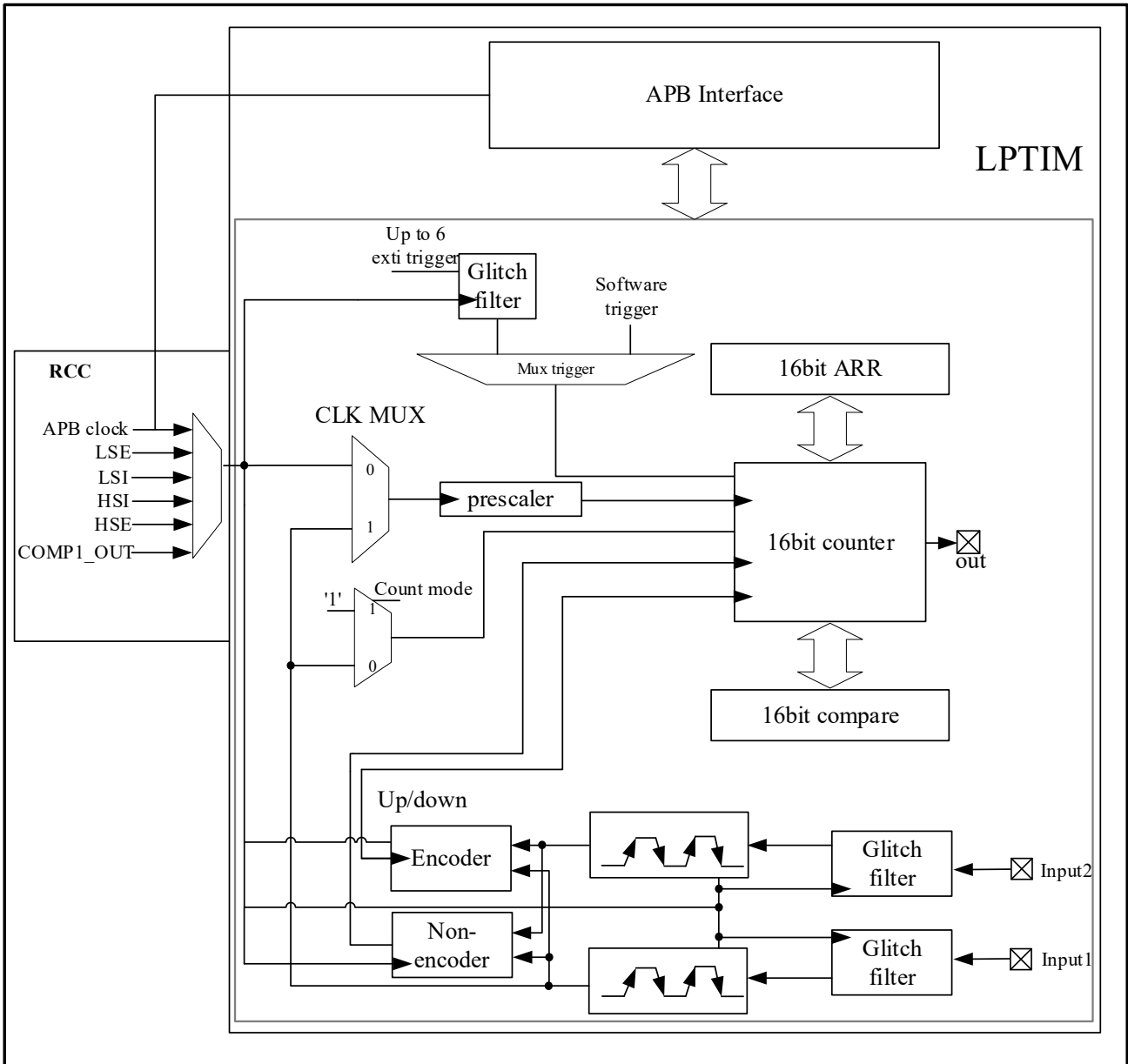
The LPTIM is a 16-bit timer with multiple clock sources, it can keep running in all power modes except for PD mode. LPTIM can run without internal clock source, it can be used as a “pulse counter”. In addition, the LPTIM can wake up the system from low-power modes, to realize “timeout functions” with extreme low power consumption.

### 12.2 Main Features

- 16-bit up-counter
- 3-bit prescaler, 8 kinds of prescaler factors (1, 2, 4, 8, 16, 32, 64, 128)
- Multiple clock sources
  - Internal: HSI, HSE, LSI, LSE, COMP\_OUT and APB1 clock
  - External: LPTIM input1 (operating without LP oscillator, for pulse counter applications)
- 16-bit auto-reload register (LPTIM\_ARR)
- 16-bit compare register (LPTIM\_COMP)
- Continuous/One-shot counting mode
- Programmable software or hardware input trigger
- Programmable digital filter for filtering glitch
- Configurable output (Square wave, PWM)
- Configurable I/O polarity
- Encoder mode
- Pulse counting mode, supports single pulse counting, double pulse counting (quadrature and non-quadrature)

### 12.3 Block Diagram

Figure 12-1 LPTIM Diagram



### 12.4 Function Description

#### 12.4.1 LPTIM Clocks and on-off Control

The LPTIM can use an internal clock source or an external clock source. The internal clock source can be selected between APB, LSI, LSE, HSE, HSI or COMP1 by configuring the RCC\_CFG2.LPTIMSEL[2:0] bits. The external clock source can be selected from comparator or GPIO. For external clock source, the LPTIM has two configurations:

- The LPTIM uses both external clock and internal clock.

- The LPTIM only use external clock from comparator or external input1. This configuration is used for low power application.

LPTIM\_CFG.CLKSEL and LPTIM\_CFG.CNTMEN bits are used for the clock source configuration. The active clock edge is configured by LPTIM\_CFG.CLKPOL[1:0] bits.

When the LPTIM only uses external clock source, it can only select one active clock edge. LPTIM can select both active clock edges only when it is using internal clock source or both external and internal clock sources.

*Note: When both effective edges of external clock are active, LPTIM needs to use an internal clock to oversample the external clock. The internal clock frequency should be at least 4 times higher than the external clock frequency.*

**12.4.2 Prescaler**

There is a configurable power of 2 predivider in front of the LPTIM counter. The prescaler ratio is controlled by the LPTIM\_CFG.CLKPRE[2:0] bits. The table below lists all the possible division ratios:

**Table 12-1 Pre-scaler Division Ratios**

| Control Bits | The Corresponding Frequency Division Factor |
|--------------|---|
| 000          | /1  |
| 001          | /2  |
| 010          | /4  |
| 011          | /8  |
| 100          | /16   |
| 101          | /32   |
| 110          | /64   |
| 111          | /128  |

**12.4.3 Glitch Filter**

LPTIM has glitch filters for inputs to filter glitches and prevent unexpected counts or triggers.

Glitch filter needs an internal clock source to operate. And the clock source should be provided before the glitch filter is enabled. This is necessary to guarantee the proper operation of the filters.

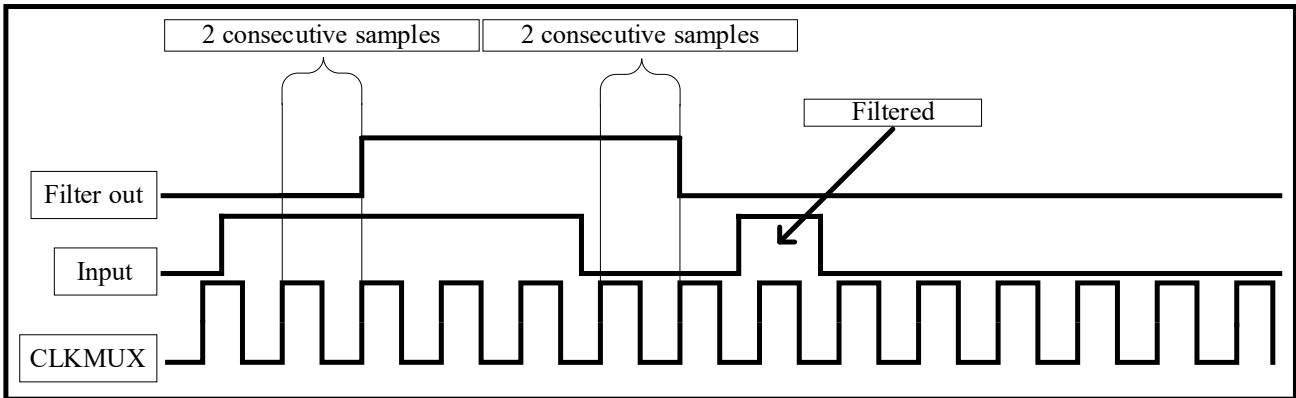
The glitch filters is divided into two groups:

- For the external inputs: The filter sensitivity is configured by the LPTIM\_CFG.CLKFLT[1:0] bits.
- For the internal trigger inputs: The filter sensitivity is configured by the LPTIM\_CFG.RIGFLT[1:0] bits.

*Note: These two groups of filters are only applicable for its corresponding inputs.*

Figure 12-2 shows the behavior of the glitch filter when 2 consecutive samples are detected. Figure 12-2 Glitch Filter

Timing Diagram



Note: If no internal clock is used, the glitch filter needs to be turned off by clearing *LPTIM\_CFG.CLKFLT[1:0]* and *LPTIM\_CFG.TRIGFLT[1:0]* bits. If glitch filter is not used, user can use digital filter in comparator or external analog filter to filter glitches.

**12.4.4 Timer Enable**

The *LPTIM\_CTRL.LPTIMEN* bit is used to enable/disable the LPTIM kernel logic.

After setting the *LPTIM\_CTRL.LPTIMEN* bit, a delay of two counter clock is needed before the LPTIM is turned on.

The *LPTIM\_CFG* and *LPTIM\_INTEN* registers must be modified only when the LPTIM is turned off.

**12.4.5 Trigger Multiplexer**

The LPTIM counter can be triggered either by software or by an effective edge on one of the 6 trigger inputs.

The trigger source is configured by *LPTIM\_CFG.TRGEN[1:0]* bits. If the *LPTIM\_CFG.TRGEN[1:0] = '00'*, the LPTIM can be triggered by *LPTIM\_CTRL.TSTCM* or *LPTIM\_CTRL.SNGMST* bit, which can be set by software. The other values of *LPTIM\_CFG.TRGEN[1:0]* are used to configure the effective edge of the trigger. The internal counter will start once an effective edge is detected.

*LPTIM\_CFG.TRGSEL[2:0]* is used to selected one of the 6 trigger inputs only when *LPTIM\_CFG.TRGEN[1:0]* is not equal to '00'.

If LPTIM is using external trigger source, which will be considered as asynchronous triggers. For asynchronous triggers, the LPTIM needs two counter clock cycles latency for synchronization.

When timeout function is disabled, new trigger event will be ignored if the LPTIM is already started.

Note: Any write to the *LPTIM\_CTRL.SNGMST/ LPTIM\_CTRL.TSTCM* bit will be discarded if the LPTIM is not enabled.

**Table 12-2 6 Trigger Inputs Corresponding to *LPTIM\_CFG.TRGSEL[2:0]* Bits**

| Control Bits | Corresponding Trigger Input |
|--------------|-----------------------------|
| 000          | PB6 or PA6                  |

|     |             |
|-----|-------------|
| 001 | RTC alarm A |
| 010 | RTC alarm B |
| 011 | RTC_TAMP1   |
| 100 | RTC_TAMP2   |
| 110 | COMP_OUT    |

### 12.4.6 Operating Mode

The LPTIM has two operating modes:

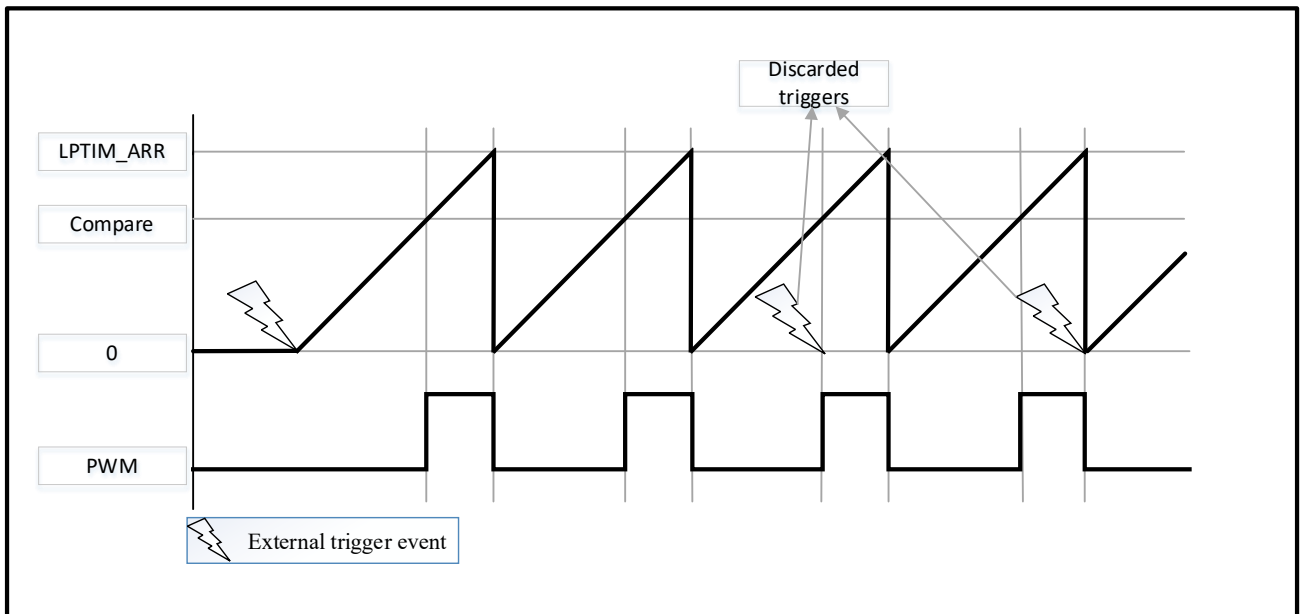
- Continuous mode: A trigger event will start the LPTIM and it will continue running until the user switched off the LPTIM.
- One-shot mode: A trigger event will start the LPTIM and it will stop when the counter value reached LPTIM\_ARR.ARRVAL[15:0].

#### Continuous mode

LPTIM\_CTRL.TSTCM bit must be set to enable the continuous mode. If LPTIM uses external trigger source, the internal counter will start when an external trigger event arrives after LPTIM\_CTRL.TSTCM bit is set. After the continuous mode starts, hardware will discard any subsequent external trigger event.

If software trigger is used, setting LPTIM\_CTRL.TSTCM bit will start the internal counter for continuous mode. Any subsequent external trigger event will be discarded as shown in **Figure 12-3**.

Figure 12-3 LPTIM Output Waveform, Continuous Counting Mode Configuration



LPTIM\_CTRL.SNGMST and LPTIM\_CTRL.TSTCM bits can only be set when LPTIM is enabled (The LPTIM\_CTRL.LPTIMEN bit is set to '1').

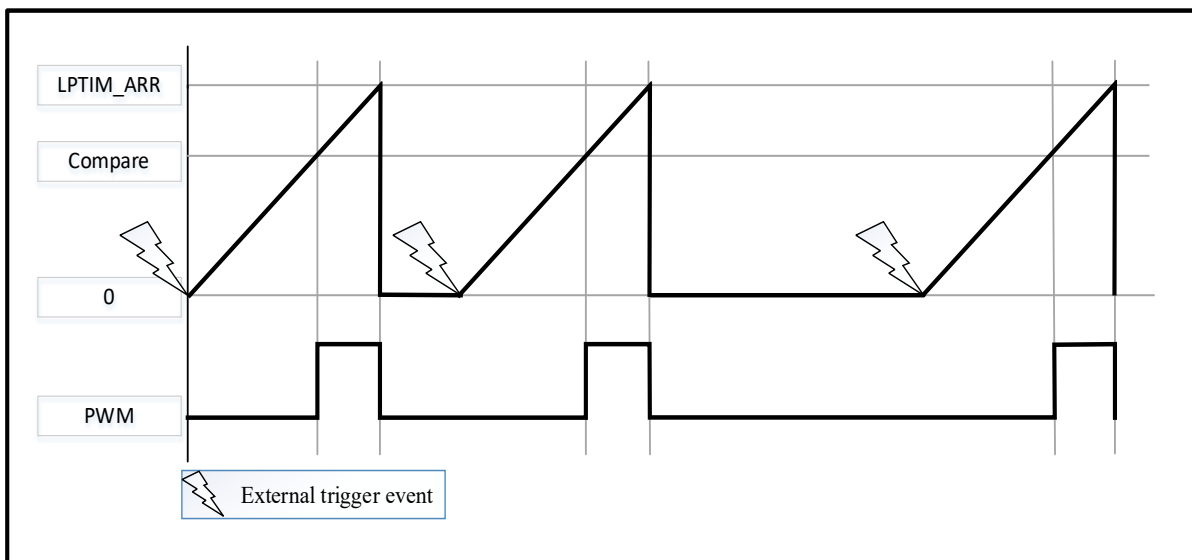
It is possible to switch from one-shot mode to continuous mode. Setting LPTIM\_CTRL.SNGMST bit will switch the LPTIM to one-shot counting mode from continuous counting mode. The counter stops as soon as it reaches the LPTIM\_ARR register value if timer enable. If the one-shot counting mode was previously selected, setting LPTIM\_CTRL.TSTCM bit to 1 will switch the LPTIM to continuous counting mode. Counter will restart as soon as LPTIM\_ARR register value is reached if timer enable.

**One-shot mode**

LPTIM\_CTRL.SNGMST bit must be set to enable the one-shot mode. A trigger event will re-start the LPTIM. Hardware will ignore all the trigger events after the internal counter starts and before the counter value equal to LPTIM\_ARR.ARRVAL[15:0] value.

If an external trigger source is selected, after setting the LPTIM\_CTRL.SNGMST bit, the timer will restart a new counting period for each external trigger event that occurs, and after the timer register stops (including zero value), as shown in **Figure 12-4**.

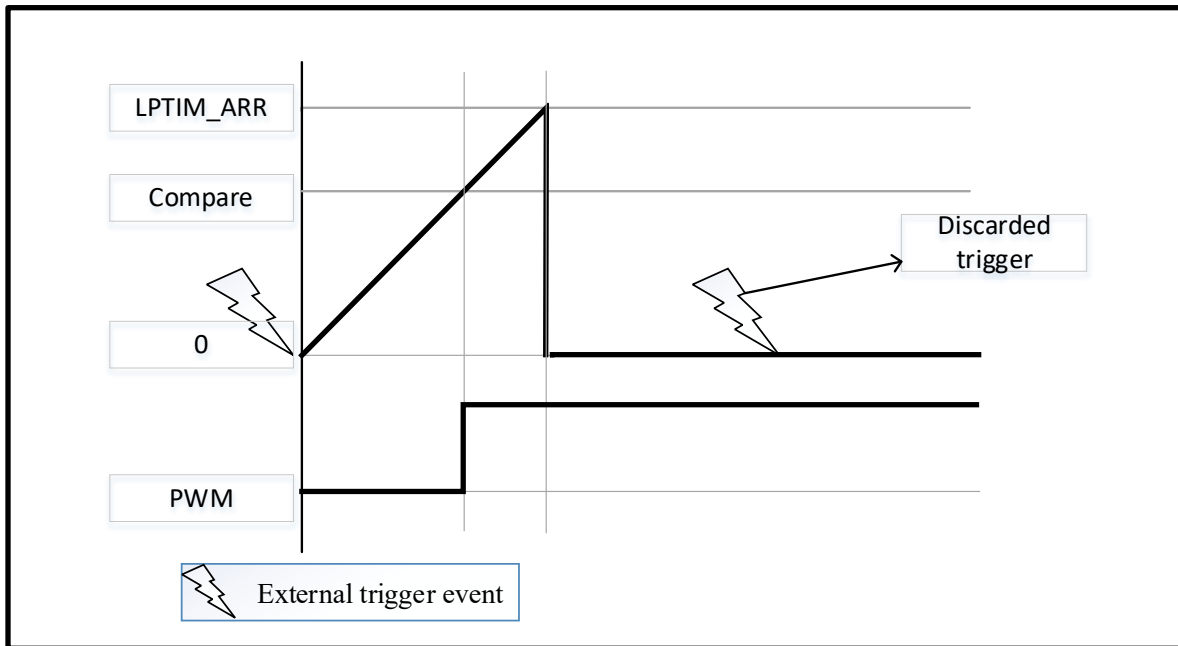
**Figure 12-4 PTIM Output Waveform, Single Counting Mode Configuration**



Set-once mode:

The Set-once mode is used when the LPTIM\_CFG.WAVE bit is set. In Set-once mode, the counter is started once the first trigger event happens, the hardware will discard any subsequent trigger event. As shown **Figure 12-5**.

Figure 12-5 LPTIM Output Waveform, Single Counting Mode Configuration and Set-once Mode Activated



In case of software start (LPTIM\_CFG.TRGEN[1:0] = '00'), the LPTIM\_CTRL.SNGMST setting will start the counter for one-shot counting.

### 12.4.7 Waveform Generation

The LPTIM auto-reload register (LPTIM\_ARR) and compare register (LPTIM\_COMP) are used for generating LPTIM output waveforms.

The waveforms supported by LPTIM are shown as below:

- PWM mode: LPTIM output is set when a COMP match event happens. (i.e. the LPTIM\_CNT register value matched the LPTIM\_COMP register value.) The LPTIM output is reset when an ARR match happens. (i.e. the LPTIM\_CNT register value matched the LPTIM\_ARR register value.)
- One-pulse mode: The first pulse is triggered same as PWM waveform, then the output is permanently reset when the ARR match happens.
- Set-once mode: the output waveform is similar to the One-pulse mode except that the output is kept to the last signal level (depending on the output configured polarity).

Above waveform configuration requires that LPTIM\_ARR register value must be configured bigger than the LPTIM\_COMP register value.

The LPTIM output waveform can be configured by the LPTIM\_CFG.WAVE bit as follow:

- Clearing the LPTIM\_CFG.WAVE bit will force the LPTIM to generate a PWM waveform or a One-pulse waveform depending on the set bit (LPTIM\_CTRL.TSTCM or LPTIM\_CTRL.SNGMST).
- Setting LPTIM\_CTRL.WAVE bit to '1' will force the LPTIM to generate a Set-once mode waveform.

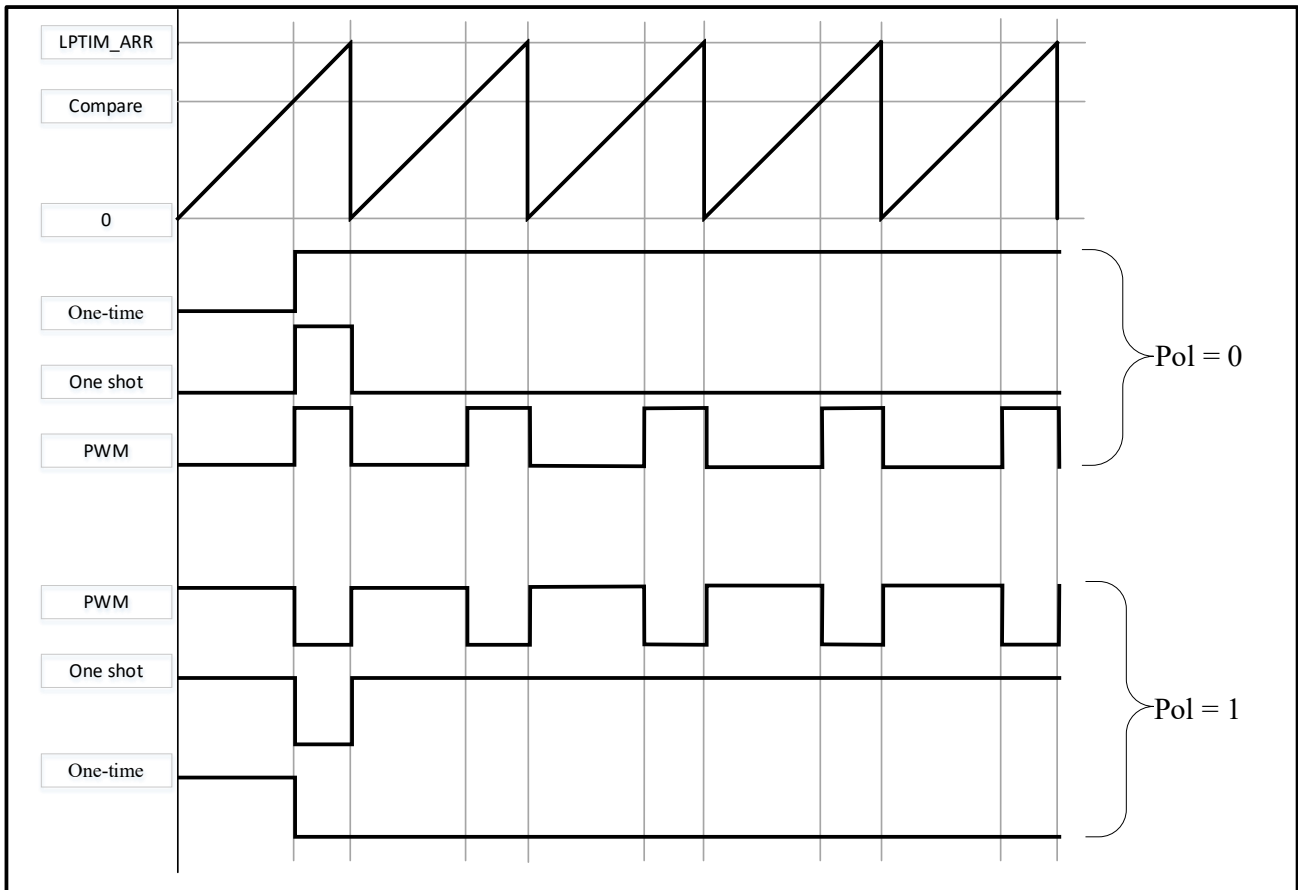
The LPTIM\_CFG.WAVEPOL bit controls LPTIM output polarity. The output default value level will change immediately

after the user configure the polarity, even when the timer is disabled.

Signals with frequencies up to the LPTIM clock frequency divided by 2 can be generated. The clock frequency division by 2 can only be achieved when the LPTIM counter counts the internal clock effectively. (i.e. LPTIM\_CFG.CLKSEL = 0, LPTIM\_CFG.CLKPOL[1:0] = 10, LPTIM\_COMP.CMPVAL[15:0] = 'd1 (50% duty cycle)'/d2, LPTIM\_ARR.ARRVAL[15:0] = 'd2. d1 and d2 means decimal 1, 2)

**Figure 12-6** below shows the three possible waveforms that can be generated on the LPTIM output. In addition, it shows the effect of the polarity change using the LPTIM\_CFG.WAVEPOL bit.

**Figure 12-6 Waveform Generation**



### 12.4.8 Register Update

The LPTIM\_ARR register and LPTIM\_COMP register can be updated after the software write operation. If the LPTIM has been started, the LPTIM\_ARR register and LPTIM\_COMP register can be updated when counter overflow.

The LPTIM APB interface and the LPTIM kernel logic use different clocks, so after an APB write operation, there is a certain delay before the written value can be used for the counter and comparators. During this latency period, any additional write operation to these registers must be avoided.

The update method of LPTIM\_ARR and LPTIM\_COMP registers is determined by the LPTIM\_CFG.RELOAD bit:

- LPTIM\_CFG.RELOAD bit equals to '1': LPTIM\_ARR and LPTIM\_COMP registers are updated when counter overflow, if the LPTIM already started. When counter overflow, latency time= 2~3 APB clock period.



- LPTIM\_CFG.RELOAD bit equals to '0': LPTIM ARR and LPTIM COMP registers are updated after any software write access. Latency = 2~3 APB clock period + 2~3 LPTIM internal pre-scaled clock period.

The LPTIM\_INTSTS.ARRUPD flag and the LPTIM\_INTSTS.CMPUPD flag indicate when the write operation is completed to respectively the LPTIM ARR register and the LPTIM COMP register.

After a write to the LPTIM ARR register or the LPTIM COMP register, any successive write before respectively the LPTIM\_INTSTS.ARRUPD flag or the LPTIM\_INTSTS.CMPUPD flag be set, will lead to unpredictable results. So a new write operation to the same register can only be performed when the previous write operation is completed.

### 12.4.9 Counter Mode

The internal counter can count external trigger events from LPTIM input1 or internal clock cycles. This can be configured through LPTIM\_CFG.CLKSEL and LPTIM\_CFG.CNTMEN bits.

If LPTIM is counting external triggers, user can configure LPTIM\_CFG.CLKPOL[1:0] bits to select the effective edge from rising edge, falling edge or both edges.

The count modes below can be selected, depending on LPTIM\_CFG.CLKSEL and LPTIM\_CFG.CNTMEN bits values:

- LPTIM\_CFG.CLKSEL = 0: the LPTIM use an internal clock source to provide the clock.
  - LPTIM\_CFG.CNTMEN = 0, The LPTIM is configured to be provided the clock by an internal clock source and the LPTIM counter is configured to be updated after each internal clock pulse.
  - LPTIM\_CFG.CNTMEN = 1, The LPTIM external Input1 is sampled with the internal clock provided to the LPTIM. In order to do not miss any event, the frequency of the changes on the external Input1 signal should never exceed the frequency of the internal clock provided to the LPTIM. In addition, the internal clock provided to the LPTIM must not be pre-scaled (LPTIM\_CFG.CLKPRE[2:0] = 000).
- LPTIM\_CFG.CLKSEL = 1: the LPTIM use an external clock source to provide the clock.
  - LPTIM\_CFG.CNTMEN bit value is irrelevant. In this configuration, the LPTIM has no need for an internal clock source (except if the glitch filters are enabled). The signal injected on the LPTIM external Input1 is used as system clock for the LPTIM. This configuration is suitable for operation modes where no embedded oscillator is enabled.
  - For this configuration, the LPTIM counter can be updated either on rising edges or falling edges of the input1 clock signal but not on both rising and falling edges.
  - Since the signal injected on the LPTIM external Input1 is also used to clock the LPTIM kernel logic, there is some initial latency (after the LPTIM is enabled) before the counter is incremented. More precisely, the first two to five effective edges on the LPTIM external Input1 (after LPTIM is enable) are lost.

### 12.4.10 Encoder Mode

The Encoder mode can handle signals from quadrature encoders which used to detect angular position of rotary elements. The encoder mode allows the counter counts the events within 0 and LPTIM\_ARR.ARRVAL[15:0] value. (0 up to LPTIM\_ARR.ARRVAL[15:0] or LPTIM\_ARR.ARRVAL[15:0] to 0). In this case, user must configure LPTIM\_ARR.ARRVAL[15:0] before enable the counter. From external input1 and input2, a clock is generated for the counter. The counting direction depends on the phase between these two input signals.

The Encoder mode is only available when the LPTIM use an internal clock source to clock. The signals frequency on both Input1 and Input2 inputs must not exceed the LPTIM internal clock frequency divided by 4. This is mandatory in order to guarantee a proper operation of the LPTIM.

The change of counting direction is updated by LPTIM\_INTSTS.DOWN and LPTIM\_INTSTS.UP flags. Also, an interrupt can be generated for both direction change events if enabled through the LPTIM\_INTEN register.

User can enable Encoder mode by setting LPTIM\_CFG.ENC bit. And the LPTIM need to be configured in continuous mode first.

When Encoder mode is active, the LPTIM counter is modified automatically following the speed and the direction of the incremental encoder. Therefore, its content always represents the encoder’s position. The count direction, signaled by LPTIM\_INTSTS.DOWN and LPTIM\_INTSTS.UP flags, correspond to the rotation direction of the encoder rotor.

Different counting scenarios may occur based on the different trigger edges configured by the LPTIM\_CFG.CLKPOL[1:0] bits. The following table summarizes the possible combinations, assuming that Input1 and Input2 do not switch at the same time.

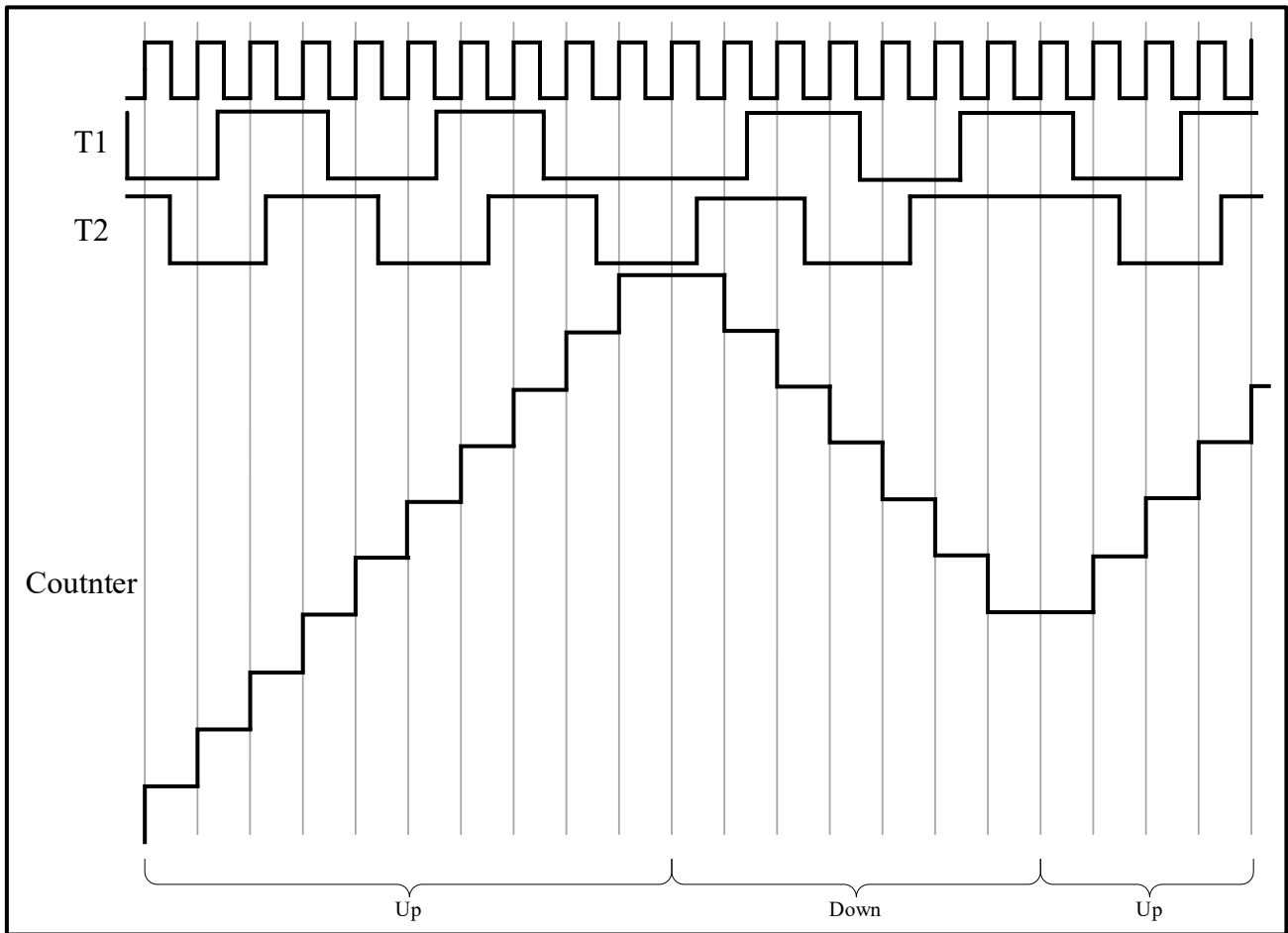
**Table 12-3 Encoder Counting Scenarios**

| Trigger Edge | The Signal Is Opposite (Input1 For Input2, Input2 For Input1) | Input1 Signal |          | Input2 Signal |          |
|--------------|---|---------------|----------|---------------|----------|
|              |   | Rising        | Falling  | Rising        | Falling  |
| Rising Edge  | High  | Down          | No count | Up            | No count |
|              | Low   | Up            | No count | Down          | No count |
| Falling Edge | High  | No count      | Up       | No count      | Down     |
|              | Low   | No count      | Down     | No count      | Up       |
| Both Edges   | High  | Down          | Up       | Up            | Down     |
|              | Low   | Up            | Down     | Down          | Up       |

The following figure shows a counting sequence for Encoder mode configured with rising and failing edge triggers.

**Caution:** In this mode the LPTIM must be clocked by an internal clock source, so the LPTIM\_CFG.CLKSEL bit must be maintained to its reset value which is equal to ‘0’. Also, the prescaler division ratio must be equal to its reset value which is 1 (LPTIM\_CFG.CLKPRE[2:0] bits must be ‘000’).

Figure 12-7 Encoder Mode Counting Sequence



### 12.4.11 Non-quadrature Encoder Mode

This mode allows handling signals from non-quadrature encoders, which is used to detect sub-sequent positive pulses from external interface. Non-Encoder interface mode acts simply as an external clock with direction selection. This means that the counter just counts continuously between 0 and the auto-reload value programmed into the LPTIM\_ARR register (0 up to ARR or ARR down to 0 depending on the direction). Therefore you must configure LPTIM\_ARR before starting. From the two external input signals, Input1 and Input2, a clock signal is generated to clock the LPTIM counter. The order between those two signals determines the counting direction.

The Non-Encoder mode is only available when the LPTIM is clocked by an internal clock source. The signals frequency on both Input1 and Input2 inputs must not exceed the LPTIM internal clock frequency divided by 4. This is mandatory in order to guarantee a proper operation of the LPTIM.

Direction change is signaled by LPTIM\_INTSTS.DOWN and LPTIM\_INTSTS.UP flags. Also, an interrupt can be generated for both direction change events if enabled through the LPTIM\_INTEN register.

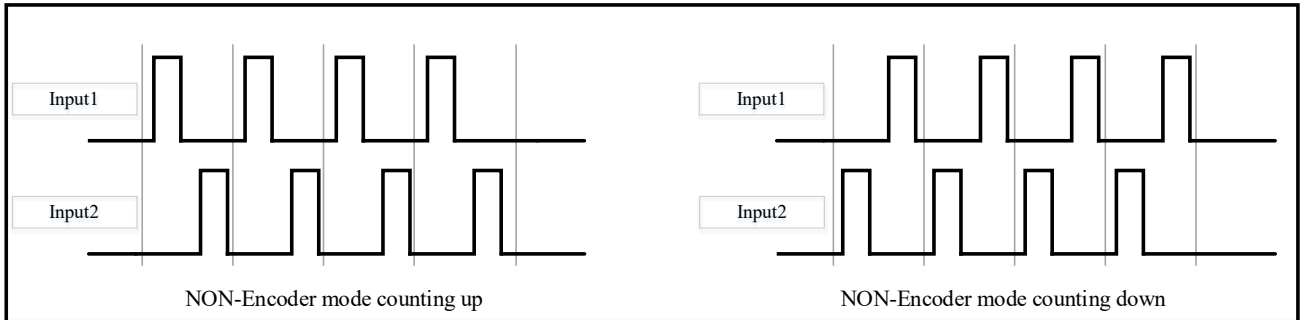
To activate the Non-Encoder mode the LPTIM\_CFG.NENC bit has to be set to '1'. The LPTIM must first be configured in Continuous mode.

When Non-Encoder mode is active, the LPTIM counter is modified automatically following the speed and the direction of the incremental encoder. Therefore, its content always represents the encoder's position. The count direction, signaled by

LPTIM\_INTSTS.DOWN and LPTIM\_INTSTS.UP flags, correspond to the rotation direction of the encoder rotor.

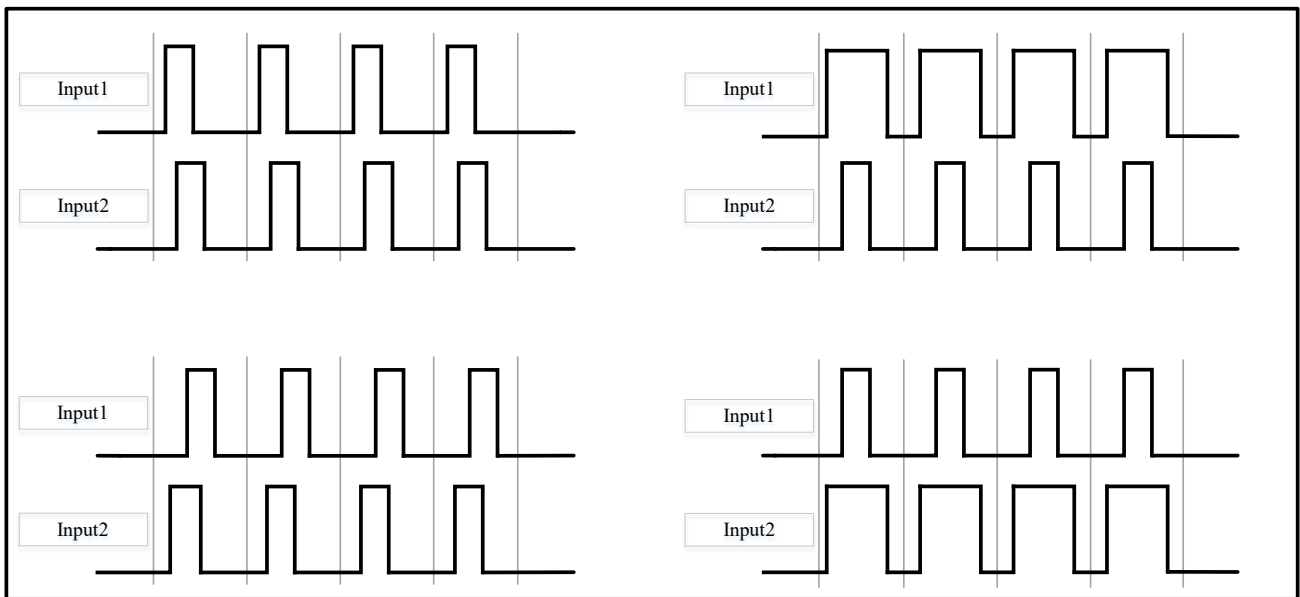
The following two waveforms, the decoder module can operate properly, when there is no case that both Input1 and Input2 are high.

**Figure 12-8 Input Waveforms of Input1 and Input2 When The Decoder Module Is Operating normally**



If the Input1 and Input2 waveform is as following, the decoder module can't operate properly. The counter will ignore these waveforms and keep the previous value.

**Figure 12-9 Input1 and Input2 Input Waveforms When Decoder Module Is Not Operating**



**12.4.12 Timeout Function**

When the LPTIM\_CFG.TIMOUTEN bit is enable, the LPTIM counter will be reset by an effective edge from one selected trigger input.

When timeout function is used, the LPTIM counter will be reset and re-start by a selected trigger input event. If no trigger occurs within the configured time, the compare match event will happen. The waiting time is configured through the timeout value.

**12.4.13 LPTIM Interrupts**

The following events generate an interrupt/wake-up event, if they are enabled through the

LPTIM\_INTEN register:

- Compare match
- Auto-reload match (whatever the direction if encoder mode)
- External trigger event
- Auto-reload register write completed
- Compare register write completed
- Direction change (encoder mode), programmable(up / down / both).

*Note: If any bit in the LPTIM\_INTEN register (Interrupt Enable Register) is set after that its corresponding flag in the LPTIM\_INTSTS register (Status Register) is set, the interrupt is not asserted.*

**Table 12-4 Interruption Events**

| Corresponding Interrupt Event  | Description  |
|--------------------------------|--|
| Compare match                  | Interrupt flag is set when LPTIM_CNT (counter register value) = LPTIM_COMP (compare register value).   |
| Auto reload match              | Interrupt flag is set when LPTIM_CNT (counter register value) = LPTIM_ARR (auto-reload register value).  |
| External trigger event         | Interrupt flag is set when an external trigger event is detected.  |
| Auto-reload register update OK | Interrupt flag is set when the write operation to the LPTIM_ARR register is complete.  |
| Compare register update OK     | Interrupt flag is set when the write operation to the LPTIM_COMP register is complete.   |
| Direction change               | Used in Encoder mode. Two interrupt flags are embedded to signal direction change:<br>–UP flag indicated that the count direction is changed to count up.<br>–DOWN flag indicated that the count direction is changed to count down. |

## 12.5 LPTIM Registers

### 12.5.1 LPTIM Register Overview

**Table 12-5 LPTIM Register Overview**

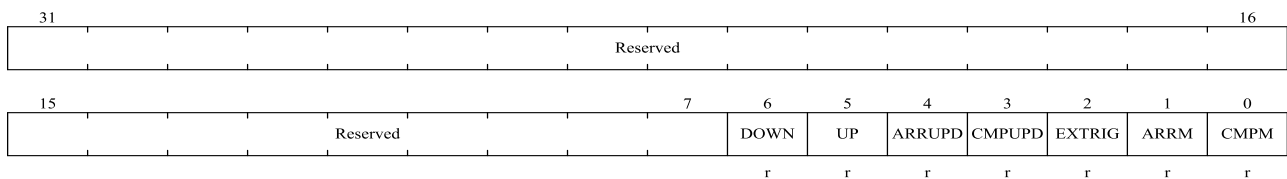
| Offset | Register     | 31       | 30 | 29 | 28 | 27 | 26 | 25 | 24 | 23 | 22 | 21 | 20 | 19 | 18 | 17 | 16 | 15 | 14 | 13 | 12 | 11 | 10 | 9 | 8 | 7      | 6    | 5        | 4        | 3        | 2      | 1      | 0 |
|--------|--------------|----------|----|----|----|----|----|----|----|----|----|----|----|----|----|----|----|----|----|----|----|----|----|---|---|--------|------|----------|----------|----------|--------|--------|---|
| 000h   | LPTIM_INTSTS | Reserved |    |    |    |    |    |    |    |    |    |    |    |    |    |    |    |    |    |    |    |    |    |   |   | DOWN   | UP   | ARRUPD   | CMPUPD   | EXTRIG   | ARRM   | CMPM   | 0 |
|        | Reset Value  |          |    |    |    |    |    |    |    |    |    |    |    |    |    |    |    |    |    |    |    |    |    |   |   | 0      | 0    | 0        | 0        | 0        | 0      | 0      |   |
| 004h   | LPTIM_INTCLR | Reserved |    |    |    |    |    |    |    |    |    |    |    |    |    |    |    |    |    |    |    |    |    |   |   | DOWNCF | UPCF | ARRUPDCF | CMPUPDCF | EXTRIGCF | ARRMCF | CMPMCF | 0 |
|        | Reset Value  |          |    |    |    |    |    |    |    |    |    |    |    |    |    |    |    |    |    |    |    |    |    |   |   | 0      | 0    | 0        | 0        | 0        | 0      | 0      |   |

| Offset | Register    | 31       | 30 | 29 | 28 | 27 | 26 | 25 | 24   | 23  | 22     | 21     | 20      | 19   | 18       | 17         | 16           | 15          | 14       | 13          | 12       | 11           | 10       | 9           | 8           | 7      | 6      | 5        | 4        | 3        | 2      | 1      | 0 |
|--------|-------------|----------|----|----|----|----|----|----|------|-----|--------|--------|---------|------|----------|------------|--------------|-------------|----------|-------------|----------|--------------|----------|-------------|-------------|--------|--------|----------|----------|----------|--------|--------|---|
| 008h   | LPTIM_INTEN | Reserved |    |    |    |    |    |    |      |     |        |        |         |      |          |            |              |             |          |             |          |              |          |             |             | DOWNIE | UPIE   | ARRUPDIE | CMPUPDIE | EXTRIGIE | ARRMIE | CMPMIE |   |
|        | Reset Value | 0        |    |    |    |    |    |    |      |     |        |        |         |      |          |            |              |             |          |             |          |              |          |             |             | 0      | 0      | 0        | 0        | 0        | 0      | 0      |   |
| 00Ch   | LPTIM_CFG   | Reserved |    |    |    |    |    |    | NENC | ENC | CNTMEN | RELOAD | WAVEPOL | WAVE | TIMOUTEN | TRGEN[1:0] | Reserved     | TRGSEL[2:0] | Reserved | CLKPRE[2:0] | Reserved | TRIGFLT[1:0] | Reserved | CLKFLT[1:0] | CLKPOL[1:0] | CLKSEL |        |          |          |          |        |        |   |
|        | Reset Value | 0        |    |    |    |    |    |    | 0    | 0   | 0      | 0      | 0       | 0    | 0        | 0          | 0            | 0           | 0        | 0           | 0        | 0            | 0        | 0           | 0           | 0      | 0      |          |          |          |        |        |   |
| 010h   | LPTIM_CTRL  | Reserved |    |    |    |    |    |    |      |     |        |        |         |      |          |            |              |             |          |             |          |              |          |             |             | TSTCM  | SNGMST | LPTIMEN  |          |          |        |        |   |
|        | Reset Value | 0        |    |    |    |    |    |    |      |     |        |        |         |      |          |            |              |             |          |             |          |              |          |             |             | 0      | 0      | 0        |          |          |        |        |   |
| 014h   | LPTIM_CMP   | Reserved |    |    |    |    |    |    |      |     |        |        |         |      |          |            | CMPVAL[15:0] |             |          |             |          |              |          |             |             |        |        |          |          |          |        |        |   |
|        | Reset Value | 0        |    |    |    |    |    |    |      |     |        |        |         |      |          |            | 0            |             |          |             |          |              |          |             |             |        |        |          |          |          |        |        |   |
| 018h   | LPTIM_ARR   | Reserved |    |    |    |    |    |    |      |     |        |        |         |      |          |            | ARRVAL[15:0] |             |          |             |          |              |          |             |             |        |        |          |          |          |        |        |   |
|        | Reset Value | 0        |    |    |    |    |    |    |      |     |        |        |         |      |          |            | 0            |             |          |             |          |              |          |             |             |        |        |          |          |          |        |        |   |
| 01Ch   | LPTIM_CNT   | Reserved |    |    |    |    |    |    |      |     |        |        |         |      |          |            | CNTVAL[15:0] |             |          |             |          |              |          |             |             |        |        |          |          |          |        |        |   |
|        | Reset Value | 0        |    |    |    |    |    |    |      |     |        |        |         |      |          |            | 0            |             |          |             |          |              |          |             |             |        |        |          |          |          |        |        |   |

### 12.5.2 LPTIM Interrupt and Status Register (LPTIM\_INTSTS)

Address offset: 0x00

Reset value: 0x0000 0000



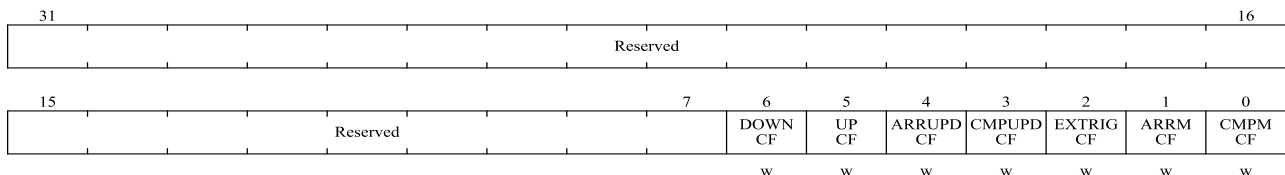
| Bit Field | Name     | Description   |
|-----------|----------|---|
| 31:7      | Reserved | Reserved, the reset value must be maintained.   |
| 6         | DOWN     | Change counter direction to down.<br>In Encoder mode, hardware will set DOWN bit to inform the application the counter direction. |
| 5         | UP       | Change counter direction to up.<br>In Encoder mode, hardware will set UP bit to inform the application the                        |

| Bit Field | Name   | Description   |
|-----------|--------|---|
|           |        | counter direction.  |
| 4         | ARRUPD | Auto-reload value updated to register.<br>Hardware sets ARRUPD to inform application that LPTIM_ARR register has been written by the APB1 bus successfully.<br>For more details, see 12.4.8.                        |
| 3         | CMPUPD | Compare value updated to register.<br>Hardware sets COMPUPD to inform application that LPTIM_COMP register has been written by the APB1 bus successfully.<br>For more details, see 12.4.8.                          |
| 2         | EXTRIG | External trigger valid event.<br>Hardware sets EXTRIG to inform application that a valid external trigger edge has occurred. If the trigger is discarded when timer has already started, then this flag is not set. |
| 1         | ARRM   | Auto-reload match.<br>Hardware set this to inform application that LPTIM_CNT register value reached the LPTIM_ARR register's value.   |
| 0         | CMPM   | Compare match.<br>Hardware set this to inform application that LPTIM_CNT register value reached the LPTIM_COMP register's value.  |

### 12.5.3 LPTIM Interrupt Clear Register (LPTIM\_INTCLR)

Address offset: 0x04

Reset value: 0x0000 0000



| Bit Field | Name     | Description  |
|-----------|----------|--|
| 31: 7     | Reserved | Reserved, the reset value must be maintained.  |
| 6         | DOWNCF   | Direction change to down Clear Flag<br>Writing 1 to this bit clear the DOWN flag in the LPTIM_INTSTS register          |
| 5         | UPCF     | Direction change to UP Clear Flag<br>Writing 1 to this bit clear the UP flag in the LPTIM_INTSTS register              |
| 4         | ARRUPDCF | Auto-reload register update OK Clear Flag<br>Writing 1 to this bit clears the ARRUPD flag in the LPTIM_INTSTS register |
| 3         | CMPUPDCF | Compare register update OK Clear Flag<br>Writing 1 to this bit clears the CMPUPD flag in the LPTIM_INTSTS register     |
| 2         | EXTRIGCF | External trigger valid edge Clear Flag<br>Writing 1 to this bit clears the EXTRIG flag in the LPTIM_INTSTS register    |

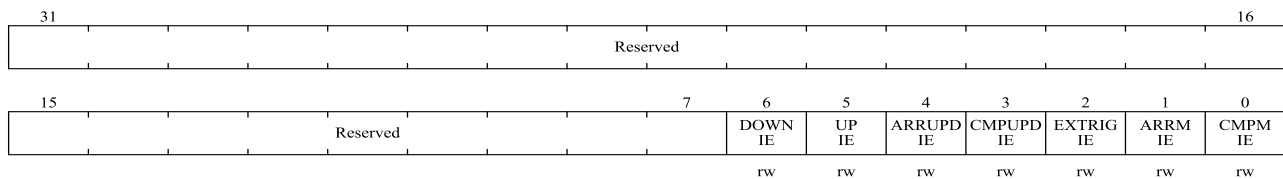
| Bit Field | Name   | Description   |
|-----------|--------|---|
| 1         | ARRMCF | Auto-reload match Clear Flag<br>Writing 1 to this bit clears the ARRM flag in the LPTIM_INTSTS register |
| 0         | CMPMCF | Compare match Clear Flag<br>Writing 1 to this bit clears the CMPM flag in the LPTIM_INTSTS register     |

### 12.5.4 LPTIM Interrupt Enable Register (LPTIM\_INTEN)

Address offset: 0x08

Reset value: 0x0000 0000

*Note: The LPTIM\_INTEN register must only be modified when the LPTIM is disabled (LPTIM\_CTRL.LPTIMEN bit reset to '0')*



| Bit Field | Name     | Description  |
|-----------|----------|--|
| 31:7      | Reserved | Reserved, the reset value must be maintained.  |
| 6         | DOWNIE   | Direction change to down interrupt enable<br>0: DOWN interrupt disabled<br>1: DOWN interrupt enabled                     |
| 5         | UPIE     | Direction change to up interrupt enable<br>0: UP interrupt disabled<br>1: UP interrupt enabled                           |
| 4         | ARRUPDIE | Auto reload register update succeeded interrupt enable bit.<br>0: ARRUPD interrupt disable<br>1: ARRUPD interrupt enable |
| 3         | CMPUPDIE | Compare register update OK interrupt enable<br>0: CMPUPD interrupt disabled<br>1: CMPUPD interrupt enabled               |
| 2         | EXTRIGIE | External trigger valid edge interrupt enable<br>0: EXTRIG interrupt disabled<br>1: EXTRIG interrupt enabled              |
| 1         | ARRMIE   | Auto reload match interrupt enable bit.<br>0: ARRM interrupt disabled<br>1: ARRM interrupt enabled                       |
| 0         | CMPMIE   | Compare match interrupt enable<br>0: CMPM interrupt disabled<br>1: CMPM interrupt enabled                                |

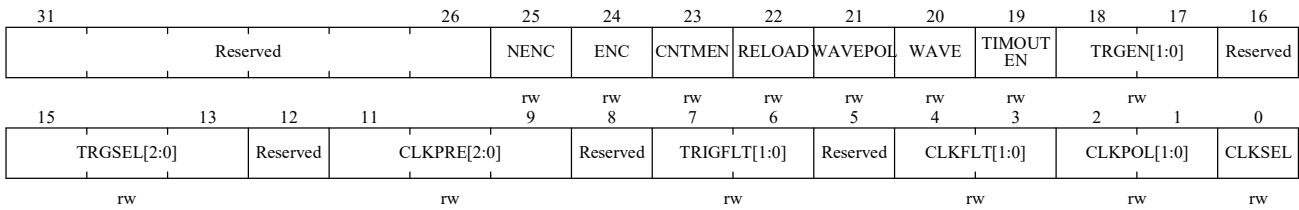
### 12.5.5 LPTIM Configuration Register (LPTIM\_CFG)

Address offset: 0x0C



Reset value: 0x0000 0000

Note: The LPTIM\_CFG register must only be modified when the LPTIM is disabled (LPTIM\_CTRL.LPTIMEN bit reset to '0')



| Bit Field | Name     | Description  |
|-----------|----------|--|
| 31:26     | Reserved | Reserved, the reset value must be maintained.  |
| 25        | NENC     | Non-Orthogonal mode enable<br>0: Non-Orthogonal mode disabled<br>1: Non-Orthogonal mode enabled  |
| 24        | ENC      | Encoder mode enable<br>0: Encoder mode disabled<br>1: Encoder mode enabled   |
| 23        | CNTMEN   | Counter mode enabled<br>The CNTMEN bit selects clock source for the LPTIM counter:<br>0: Counter is incremented following each internal clock pulse<br>1: Counter is incremented following each valid clock pulse on the LPTIM external Input1                                       |
| 22        | RELOAD   | Registers update mode<br>The RELOAD bit controls the LPTIM_ARR and the LPTIM_COMP registers update mode<br>0: Registers are updated after each APB1 bus write access<br>1: Registers are updated at the end of the current LPTIM period  |
| 21        | WAVEPOL  | Waveform shape polarity<br>The WAVEPOL bit controls the output polarity<br>0: The LPTIM output reflects the compare results between LPTIM_ARR and LPTIM_COMP registers<br>1: The LPTIM output reflects the inverse of the compare results between LPTIM_ARR and LPTIM_COMP registers |
| 20        | WAVE     | Waveform shape<br>The WAVE bit controls the output shape<br>0: Deactivate single pulse mode, PWM/One Pulse waveform (depending on LPTIM_CTRL.TSTCM or LPTIM_CTRL.SNGMST bit)<br>1: Activate the single pulse mode  |
| 19        | TIMOUTEN | Timeout enable<br>0: A trigger event arriving when the timer is already started will be ignored<br>1: A trigger event arriving when the timer is already started will reset and restart the counter  |

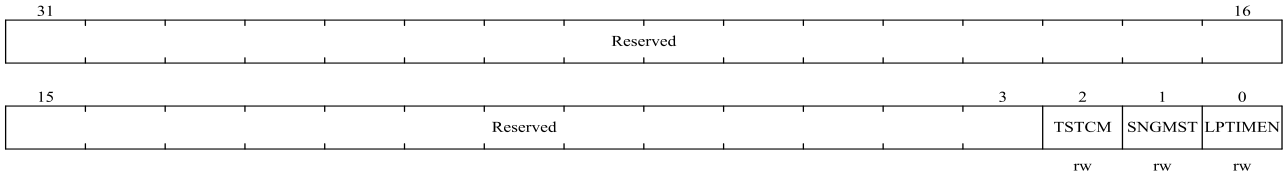
| Bit Field | Name         | Description  |
|-----------|--------------|--|
| 18:17     | TRGEN[1:0]   | <p>Trigger enable and polarity</p> <p>The TRGEN bits controls whether the LPTIM counter is started by an external trigger or not. If the external trigger option is selected, three configurations are possible for the trigger effective edge:</p> <p>00: Software trigger (counting start is initiated by software)</p> <p>01: Rising edge is the effective edge</p> <p>02: Falling edge is the effective edge</p> <p>03: Both edges are effective edges</p>   |
| 16        | Reserved     | Reserved, the reset value must be maintained.  |
| 15:13     | TRGSEL[2:0]  | <p>Trigger selector</p> <p>The trigger source is selected from the following 6 available sources as the trigger event for LPTIM:</p> <p>000: PB6 or PA6</p> <p>001: RTC alarm A</p> <p>010: RTC alarm B</p> <p>011: RTC_TAMP1</p> <p>100: RTC_TAMP2</p> <p>101: Reserved</p> <p>110: COMP_OUT</p> <p>111: Reserved</p>   |
| 12        | Reserved     | Reserved, the reset value must be maintained.  |
| 11:9      | CLKPRE[2:0]  | <p>Clock division factor bit.</p> <p>000: / 1</p> <p>001: / 2</p> <p>010: / 4</p> <p>011: / 8</p> <p>100: / 16</p> <p>101: / 32</p> <p>110: / 64</p> <p>111: / 128</p>   |
| 8         | Reserved     | Reserved, the reset value must be maintained.  |
| 7:6       | TRIGFLT[1:0] | <p>Configure the data filter trigger bit.</p> <p>The TRIGFLT value sets the number of consecutive equal samples that should be detected when a level change occurs on an internal trigger before it is considered as a valid level transition. An internal clock source must be present to use this feature</p> <p>00: Any trigger active level change is considered as a valid trigger.</p> <p>01: Trigger active level change must be stable for at least 2 clock periods before it is considered as valid trigger.</p> <p>10: Trigger active level change must be stable for at least 4 clock periods before it is considered as valid trigger.</p> |

| Bit Field | Name        | Description  |
|-----------|-------------|--|
|           |             | 11: Trigger active level change must be stable for at least 8 clock periods before it is considered as valid trigger.  |
| 5         | Reserved    | Reserved, the reset value must be maintained.  |
| 4:3       | CLKFLT[1:0] | <p>Digital filter external clock input configuration</p> <p>The CLKFLT value sets the number of consecutive equal samples that should be detected when a level change occurs on an external clock signal before it is considered as a valid level transition. An internal clock source must be present to use this feature</p> <p>00: Any external clock signal level change is considered as a valid transition.</p> <p>01: External clock signal level change must be stable for at least 2 clock periods before it is considered as valid transition.</p> <p>10: External clock signal level change must be stable for at least 4 clock periods before it is considered as valid transition.</p> <p>11: External clock signal level change must be stable for at least 8 clock periods before it is considered as valid transition.</p> |
| 2:1       | CLKPOL[1:0] | <p>Clock polarity</p> <p>When the LPTIM is clocked by an external clock source, CLKPOL bits is used to configure the effective edge or edges used by the counter:</p> <p>00: The rising edge is the effective edge used for counting</p> <p>01: The falling edge is the effective edge used for counting</p> <p>10: Both edges are effective edges. When both external clock signal edges are considered active ones, the LPTIM must also be clocked by an internal clock source with a frequency equal to at least four time the external clock frequency.</p> <p>11: Not allowed</p> <p>If the LPTIM is configured in Encoder mode (LPTIM_CFG.ENC bit is set):</p> <p>00: The encoder rising edge counting mode.</p> <p>01: The encoder falling edge counting mode.</p> <p>02: The encoder both edges counting mode.</p>                 |
| 0         | CLKSEL      | <p>Clock selector</p> <p>The CLKSEL bit selects which clock source the LPTIM will use:</p> <p>0: LPTIM is clocked by internal clock source (APB1 clock or any of the embedded oscillators)</p> <p>1: LPTIM is clocked by an external clock source through the LPTIM external Input1</p>  |

### 12.5.6 LPTIM Control Register (LPTIM\_CTRL)

Address offset: 0x10

Reset value: 0x0000 0000



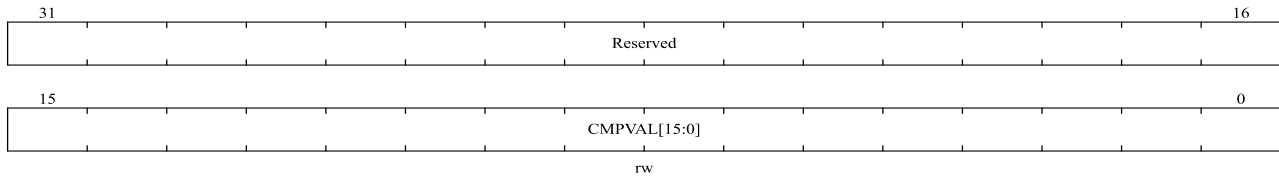
| Bit Field | Name     | Description   |
|-----------|----------|---|
| 31:3      | Reserved | Reserved, the reset value must be maintained.   |
| 2         | TSTCM    | <p>Timer start in Continuous mode</p> <p>This bit is set by software and cleared by hardware.</p> <p>In case of software start (LPTIM_CFG.TRGEN[1:0] = '00'), setting this bit starts the LPTIM in Continuous mode.</p> <p>If the software start is disabled (TRGEN[1:0] ≠ '00'), setting this bit starts the timer in Continuous mode as soon as an external trigger is detected.</p> <p>If this bit is set when a single pulse mode counting is ongoing, then the timer will not stop at the next match between the LPTIM_ARR and LPTIM_CNT registers and the LPTIM counter keeps counting in Continuous mode.</p> <p>This bit can be set only when the LPTIM is enabled. It will be automatically reset by hardware.</p> |
| 1         | SNGMST   | <p>LPTIM start in Single mode</p> <p>This bit is set by software and cleared by hardware.</p> <p>In case of software start (LPTIM_CFG.TRGEN[1:0] = '00'), setting this bit starts the LPTIM in single pulse mode.</p> <p>If the software start is disabled (LPTIM_CFG.TRGEN[1:0] ≠ '00'), setting this bit starts the LPTIM in single pulse mode as soon as an external trigger is detected.</p> <p>If this bit is set when the LPTIM is in continuous counting mode, then the LPTIM will stop at the following match between LPTIM_ARR and LPTIM_CNT registers.</p> <p>This bit can only be set when the LPTIM is enabled. It will be automatically reset by hardware.</p>   |
| 0         | LPTIMEN  | <p>LPTIM enable</p> <p>The LPTIMEN bit is set and cleared by software.</p> <p>0: LPTIM is disabled</p> <p>1: LPTIM is enabled</p>   |

### 12.5.7 LPTIM Compare Register (LPTIM\_COMP)

Address offset: 0x14

Reset value: 0x0000 0000

*Note: The LPTIM\_COMP register must only be modified when the LPTIM is enabled (LPTIM\_CTRL.LPTIMEN bit reset to '1')*



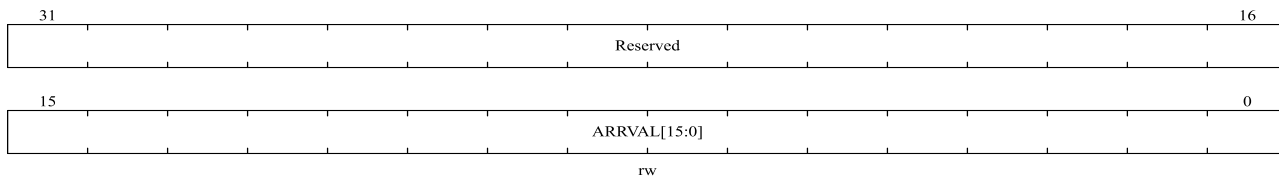
| Bit Field | Name         | Description   |
|-----------|--------------|---|
| 31:16     | Reserved     | Reserved, the reset value must be maintained.                   |
| 15:0      | CMPVAL[15:0] | Compare value<br>CMPVAL is the compare value used by the LPTIM. |

### 12.5.8 LPTIM Auto-reload Register (LPTIM\_ARR)

Address offset: 0x18

Reset value: 0x0000 0001

*Note: The LPTIM\_ARR register must only be modified when the LPTIM is enabled (LPTIM\_CTRL.LPTIMEN bit reset to '1')*

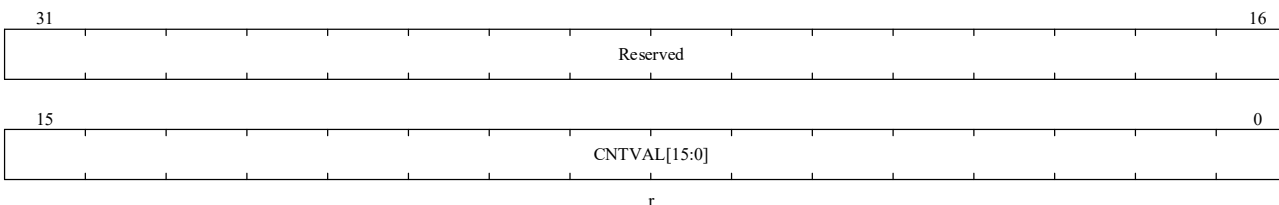


| Bit Field | Name         | Description  |
|-----------|--------------|--|
| 31:16     | Reserved     | Reserved, the reset value must be maintained.  |
| 15:0      | ARRVAL[15:0] | Auto reload value<br>ARRVAL is the auto-reload value for the LPTIM.<br>This value must be strictly greater than the LPTIM_COMP.CMPVAL[15:0] value. |

### 12.5.9 LPTIM Counter Register (LPTIM\_CNT)

Address offset: 0x1C

Reset value: 0x0000 0000



| Bit Field | Name         | Description  |
|-----------|--------------|--|
| 31:16     | Reserved     | Reserved, the reset value must be maintained.                                      |
| 15:0      | CNTVAL[15:0] | Counter value<br>When the LPTIM is running with an asynchronous clock, reading the |

| Bit Field | Name | Description   |
|-----------|------|---|
|           |      | <p>LPTIM_CNT register may return unreliable values. So in this case it is necessary to perform two consecutive read accesses and verify that the two returned values are identical.</p> <p>If identical, the reading is reliable.</p> |

## 13 Independent Watchdog (IWDG)

### 13.1 Introduction

The N32G031 has embedded independent watchdog (IWDG) and window watchdog (WWDG) timers to solve the problems caused by software errors. The watchdog timer is very flexible to use, which improves the security of the system and the accuracy of timing control.

The independent watchdog (IWDG) is driving by low-speed internal clock (LSI clock) running at 30 KHz, which will still running event dead loop or MCU stuck is happening. This can provide higher safety level, timing accuracy and flexibility of watchdog. It can resolve system malfunctions due to software failure by reset. The IWDG is best suited for applications that require the watchdog to run as a totally independent process outside the main application with relatively low timing accuracy requirements.

When the power control register PWR\_CTRL2.IWDGRSTEN bit is '1' and the IWDG counter reaches 0, a system reset will be generated (if this bit is '0', the IWDG will count but not reset). IWDG reset can also be used for low power wake up.

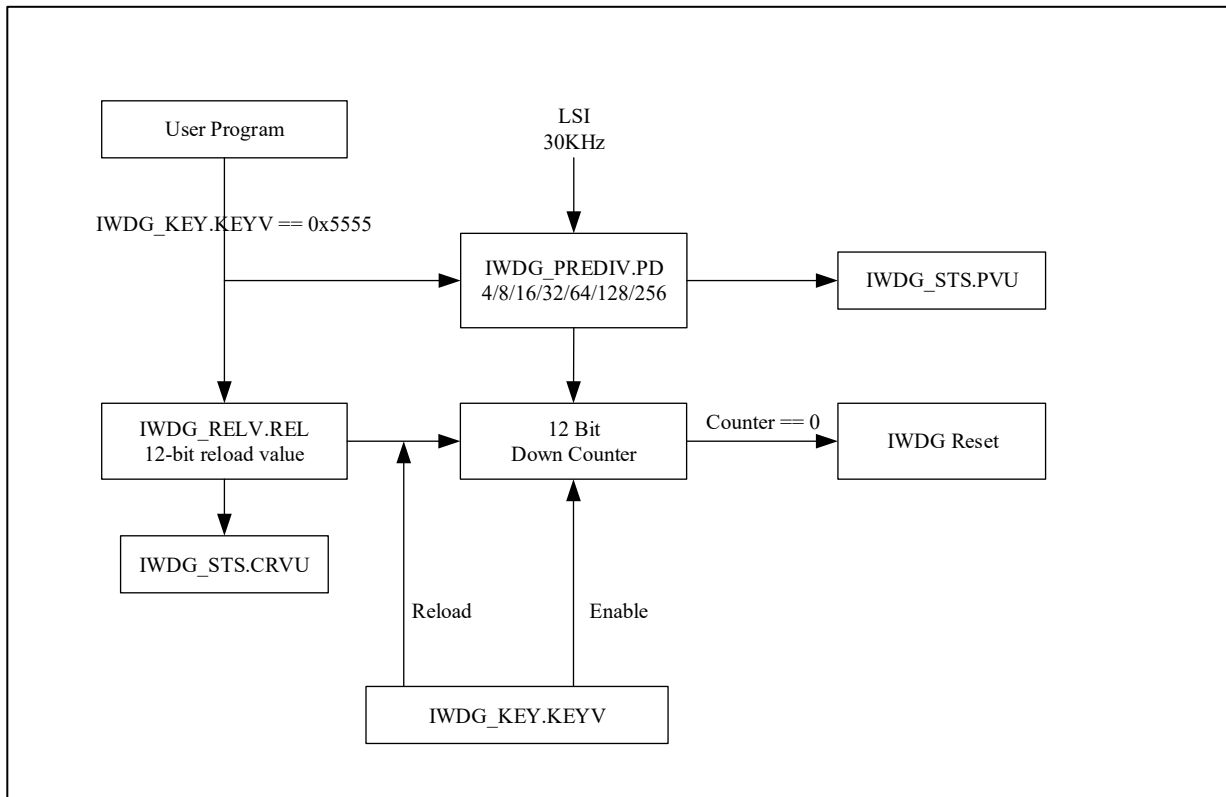
*Note: This chapter is based on the system default value IWDGRSTEN = 1.*

### 13.2 Main Features

- A 12-bit down-counter that runs independently
- RC oscillator provides an independent clock source and can operate normally in STOP mode
- Reset and low-power wake-up can be matched.
- A system reset occurs when the down counter reaches 0x0000 (if watchdog is activated)

### 13.3 Function Description

Figure 13-1 Functional Block Diagram of The Independent Watchdog Module



To enable IWDG, we need to write 0xCCCC to IWDG\_KEY.KEYV[15:0] bits. Counter starts counting down from reset value (0xFFFF). When counter count to 0x000, it generates a reset signal (IWDG\_RESET) to MCU. Other than that, as long as 0xAAAA (reload request) is write to IWDG\_KEY.KEYV[15:0] bits before reset, the counter value is set to the reload value in the IWDG\_RELV.REL[11:0] bits and prevents the watchdog from resetting the entire device.

If the 'hardware watchdog timer' function is enabled through the option byte, the watchdog will automatically start running after the system is powered on and will generate a system reset, unless the software reloads the counter before it reaches '0'.

#### 13.3.1 Register Access Protection

IWDG\_PREDIV and IWDG\_RELV register are write protection. To modify the value of those two register, user needs to write 0x5555 to IWDG\_KEY.KEYV[15:0] bits. Writing other value will enable write protection again. IWDG\_STS.PVU indicates whether the pre-scaler value update is on going. IWDG\_STS.CRVU indicates whether the IWDG is updating the reload value. The hardware sets the IWDG\_STS.PVU bit and/or IWDG\_STS.CRVU bit when the pre-scaler value and/or reload value is updating. After the pre-scaler value and/or reload value update is complete, the hardware clears the IWDG\_STS.PVU bit and/or IWDG\_STS.CRVU bit.

The reload operation (writing 0xAAAA to IWDG\_KEY.KEYV[15:0]) will also enable the registers to become write protection again.



### 13.3.2 Debug Mode

In debug mode (Cortex<sup>®</sup>-M0 core stops), IWDG counter will either continue to operate normally or stop, depending on DBG\_CTRL.IWDG\_STOP bit in debug module. If this bit is set to '1', the counter stops. If this bit is set to '0', the counter operate normally. For details, refer to 3.3.2 Peripheral Debugging Support.

## 13.4 User Interface

IWDG module user interface contains 4 registers: key register (IWDG\_KEY), pre-scale register (IWDG\_PREDIV), reload register (IWDG\_RELV) and status register (IWDG\_STS).

### 13.4.1 Operating Process

When IWDG is enabled by software (writing 0xAAAA to IWDG\_KEY.KEYV[15:0] bits) or hardware (clearing FLASH\_OB.WDG\_SW bit). It starts counting down from 0xFFFF. Down counting gap is determined by pre-scale LSI clock. Once the counter is reloaded, the new round will start from the value in IWDG\_RELV.REL[11:0] instead of 0xFFFF.

When program is running normally, software needs to feed IWDG before counter reaches 0 and start a new round of down counting. When counter reaches 0, this indicates program malfunction. In this case, IWDG generates a reset signal.

If user wants to configure IWDG pre-scale and reload value register, the user needs to write 0x5555 to IWDG\_KEY.KEYV[15:0] first, then confirm IWDG\_STS.CRVU bit and IWDG\_STS.PVU bit. IWDG\_STS.CRVU bit indicates reload value update is ongoing, IWDG\_STS.PVU indicates pre-scale value is updating. Only when those two bit are 0 then user can update corresponding value. When update is on-going, hardware sets corresponding bit to 1. At this time, reading IWDG\_PREDIV.PD[2:0] or IWDG\_RELV.REL[11:0] is invalid since data needs to be synchronized to LSI clock domain. The value read from IWDG\_PREDIV.PD[2:0] or IWDG\_RELV.REL[11:0] will be valid after hardware clears the IWDG\_STS.PVU bit or IWDG\_STS.CRVU bit.

If the application uses more than one reload value or pre-scaler value, it must wait until the IWDG\_STS.CRVU bit is reset before changing the reload value, the same as changing the pre-scaler value. However, after updating the prescaler value and reload value, or only updating the prescaler value, or only updating the reload value, there is no need to wait for the IWDG\_STS.CRVU bit or IWDG\_STS.PVU bit to be reset before continuing to execute the code (even if in low-power mode, write operations will be considered and completed).

Pre-scale register and reload register control the time that generating reset, as shown in **Table 13-1**.

**Table 13-1 IWDG Counting Maximum and Minimum Reset Time**

| Pre-Scale Factor | PD[2:0] | Min Timeout (ms)<br>REL [11:0]=0x000 | Max Timeout (ms)<br>REL [11:0]=0xFFFF |
|------------------|---------|--------------------------------------|---------------------------------------|
| / 4              | 000     | 0.13                                 | 546.13                                |
| / 8              | 001     | 0.26                                 | 1092.27                               |
| / 16             | 010     | 0.53                                 | 2184.53                               |
| / 32             | 011     | 1.07                                 | 4369.07                               |
| / 64             | 100     | 2.13                                 | 8738.13                               |
| / 128            | 101     | 4.26                                 | 17476.27                              |
| / 256            | 11x     | 8.53                                 | 34952.53                              |

### 13.5 IWDG Registers

#### 13.5.1 IWDG Register Overview

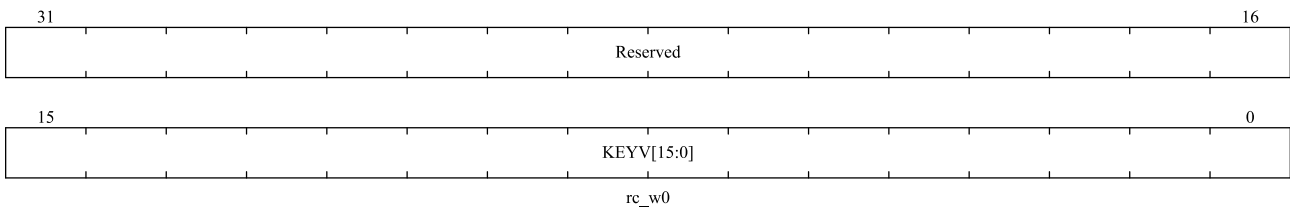
Table 13-2 IWDG Register Overview

| Offset | Register    | 31       | 30 | 29 | 28 | 27 | 26 | 25 | 24 | 23 | 22 | 21 | 20        | 19 | 18 | 17 | 16 | 15         | 14 | 13 | 12 | 11 | 10 | 9 | 8 | 7       | 6   | 5 | 4 | 3 | 2 | 1 | 0 |   |   |   |   |
|--------|-------------|----------|----|----|----|----|----|----|----|----|----|----|-----------|----|----|----|----|------------|----|----|----|----|----|---|---|---------|-----|---|---|---|---|---|---|---|---|---|---|
| 0x00   | IWDG_KEY    | Reserved |    |    |    |    |    |    |    |    |    |    |           |    |    |    |    | KEYV[15:0] |    |    |    |    |    |   |   |         |     |   |   |   |   |   |   |   |   |   |   |
|        | Reset value |          |    |    |    |    |    |    |    |    |    |    |           |    |    |    |    | 0          | 0  | 0  | 0  | 0  | 0  | 0 | 0 | 0       | 0   | 0 | 0 | 0 | 0 | 0 | 0 | 0 | 0 | 0 | 0 |
| 0x04   | IWDG_PREDIV | Reserved |    |    |    |    |    |    |    |    |    |    |           |    |    |    |    |            |    |    |    |    |    |   |   | PD[2:0] |     |   |   |   |   |   |   |   |   |   |   |
|        | Reset value |          |    |    |    |    |    |    |    |    |    |    |           |    |    |    |    |            |    |    |    |    |    |   |   | 0       | 0   | 0 |   |   |   |   |   |   |   |   |   |
| 0x08   | IWDG_RELV   | Reserved |    |    |    |    |    |    |    |    |    |    | REL[11:0] |    |    |    |    |            |    |    |    |    |    |   |   |         |     |   |   |   |   |   |   |   |   |   |   |
|        | Reset value |          |    |    |    |    |    |    |    |    |    |    | 1         | 1  | 1  | 1  | 1  | 1          | 1  | 1  | 1  | 1  | 1  | 1 |   |         |     |   |   |   |   |   |   |   |   |   |   |
| 0x0C   | IWDG_STS    | Reserved |    |    |    |    |    |    |    |    |    |    |           |    |    |    |    |            |    |    |    |    |    |   |   | CRVU    | PVU |   |   |   |   |   |   |   |   |   |   |
|        | Reset value |          |    |    |    |    |    |    |    |    |    |    |           |    |    |    |    |            |    |    |    |    |    |   |   | 0       | 0   |   |   |   |   |   |   |   |   |   |   |

#### 13.5.2 IWDG Key Register (IWDG\_KEY)

Address offset: 0x00

Reset value: 0x00000000

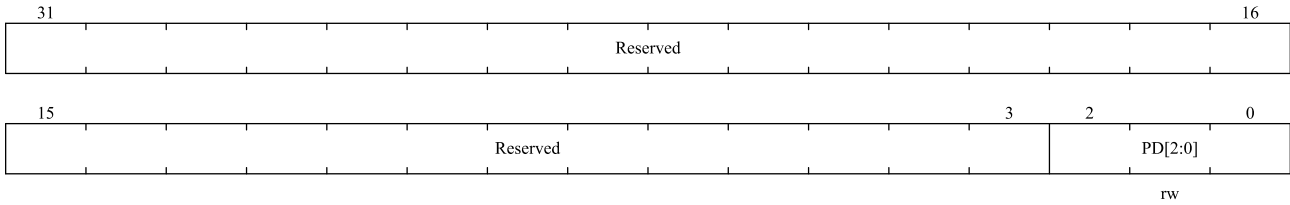


| Bit Field | Name       | Description  |
|-----------|------------|--|
| 31:16     | Reserved   | Reserved, the reset value must be maintained.  |
| 15:0      | KEYV[15:0] | Key value register: only certain value will serve particular function<br>0xCCCC: Start watch dog counter, does not have any effect if hardware watchdog is enable, (if hardware watchdog is selected, it is not limited by this command word)<br>0xAAAA: Reload counter with REL value in IWDG_RELV register to prevent reset.<br>0x5555: Disable write protection of IWDG_PREDIV and IWDG_RELV register |

#### 13.5.3 IWDG Pre-scaler Register (IWDG\_PREDIV)

Address offset: 0x04

Reset value: 0x00000000

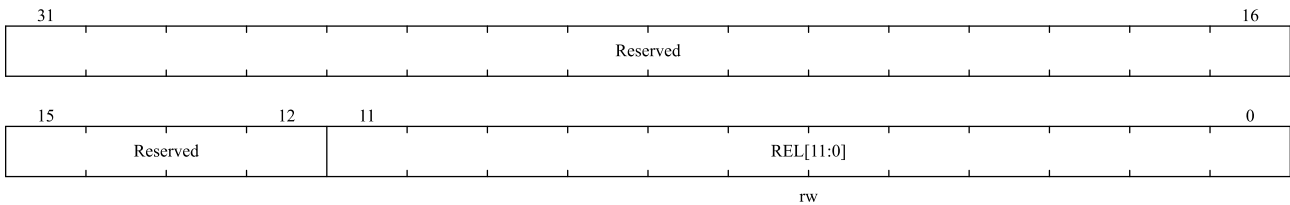


| Bit Field | Name     | Description  |
|-----------|----------|--|
| 31:3      | Reserved | Reserved, the reset value must be maintained.  |
| 2:0       | PD[2:0]  | <p>Pre-frequency division factor</p> <p>Pre-scaler divider: with write access protection when IWDG_KEY.KEYV[15:0] is not 0x5555. The IWDG_STS.PVU bit must be 0 otherwise PD [2:0] value cannot be changed.</p> <p>Divide number is as follow:</p> <p>000: divider /4<br/>                     001: divider /8<br/>                     010: divider /16<br/>                     011: divider /32<br/>                     100: divider /64<br/>                     101: divider /128<br/>                     Other : divider /256</p> <p><i>Note: Reading this register will return the pre-divided value from the V<sub>DD</sub> voltage domain. If a write operation is in progress, the read-back value may be invalid. Therefore, the read value is valid only when the IWDG_STS.PVU bit is '0'.</i></p> |

### 13.5.4 IWDG Reload Register (IWDG\_RELV)

Address offset: 0x08

Reset value: 0x00000FFF



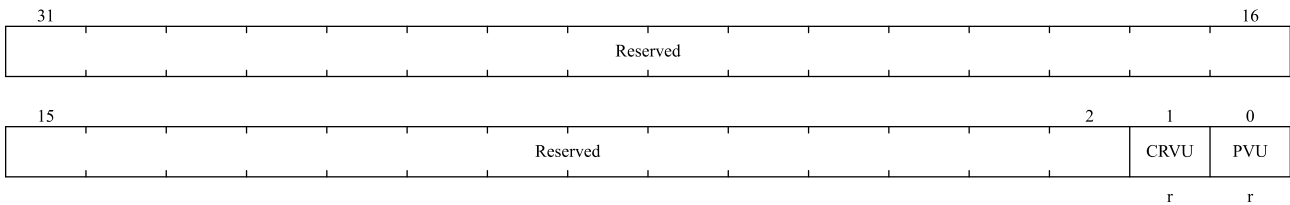
| Bit Field | Name     | Description                                   |
|-----------|----------|---|
| 31:12     | Reserved | Reserved, the reset value must be maintained. |

| Bit Field | Name      | Description  |
|-----------|-----------|--|
| 11:0      | REL[11:0] | <p>Watchdog counter reload value.</p> <p>With write protection. Defines the reload value of the watchdog counter, which is loaded to the counter every time 0xAAAA is written to IWDG_KEY.KEYV[15:0] bits. The counter then starts to count down from this value. The watchdog timeout period can be calculated from this reloading value and the clock pre-scaler value, refer to Table 13-1.</p> <p>This register can only be modified when the IWDG_STS.CRVU bit is '0'.</p> <p><i>Note: Reading this register will return the reload value from the V<sub>DD</sub> voltage domain. If a write operation is in progress, the read-back value may be invalid. Therefore, the read value is valid only when the IWDG_STS.CRVU bit is '0'.</i></p> |

### 13.5.5 IWDG Status Register (IWDG\_STS)

Address offset: 0x0C

Reset value: 0x00000000



| Bit Field | Name     | Description   |
|-----------|----------|---|
| 31:2      | Reserved | Reserved, the reset value must be maintained.   |
| 1         | CRVU     | <p>Watchdog reload value update</p> <p>Reload Value Update: this bit indicates an update of reload value is ongoing. Set by hardware and clear by hardware. Software can only try to change IWDG_RELV.REL[11:0] value when IWDG_KEY.KEYV[15:0] bits' value is 0x5555 and this bit is 0.</p>             |
| 0         | PVU      | <p>Watchdog pre-scaler value update</p> <p>Pre-scaler Value Update: this bit indicates an update of pre-scaler value is ongoing. Set by hardware and clear by hardware. Software can only try to change IWDG_PREDIV.PD[2:0] value when IWDG_KEY.KEYV[15:0] bits' value is 0x5555 and this bit is 0.</p> |

## 14 Window Watchdog (WWDG)

### 14.1 Introduction

The clock of the window watchdog (WWDG) is obtained by dividing the APB1 clock frequency by 4096, and whether the program operation is abnormal is detected through the configuration of the time window. Therefore, WWDG is suitable for precise timing, and is often used to monitor software failures where the application deviates from its normal operation

sequence due to external interference or unforeseen logic conditions.. A system reset occurs when the WWDG down counter is refreshed before reaching the window register value or after the WWDG\_CTRL.T6 bit becomes 0.

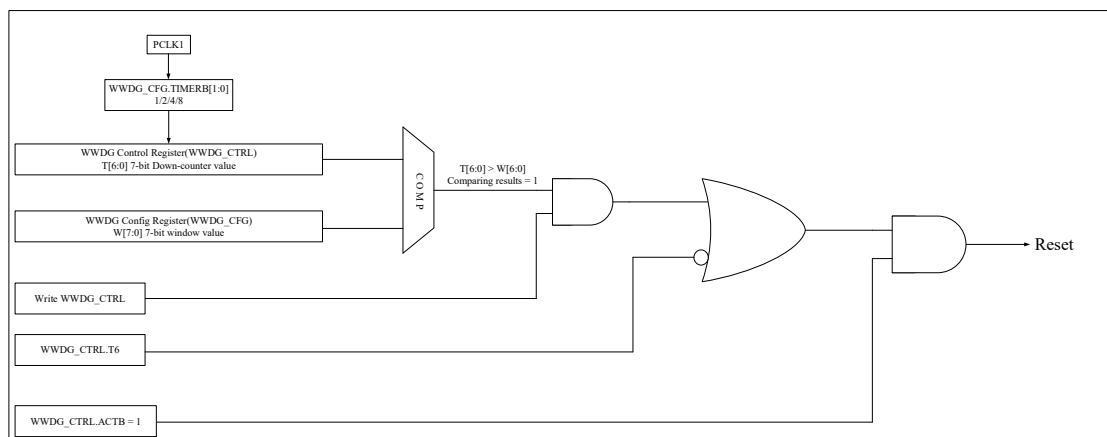
### 14.2 Main Features

- 7-bit independent running programmable down counter
- After WWDG is enabled, a reset occurs under the following conditions
  - The value of the down counter is less than 0x40.
  - When the down counter value is greater than the value of the window register, it is reloaded.
- Early wake-up interrupt: If the watchdog is started and the interrupt is enabled, wake-up interrupt (WWDG\_CFG.EWINT) will be triggered when the count value reaches 0x40.

### 14.3 Function Description

If the watchdog is activated (the WWDG\_CTRL.ACTB bit), when the 7-bit (WWDG\_CTRL.T[6:0]) down-counter reaches 0x3F(WWDG\_CTRL.T6 bit is cleared), or the software reloads the counter when the counter value is greater than the value of the window register, a system reset will be generated. In order to avoid system reset, the software must periodically refresh the counter value in the window during normal operation.

**Figure 14-1 Watchdog Block Diagram**



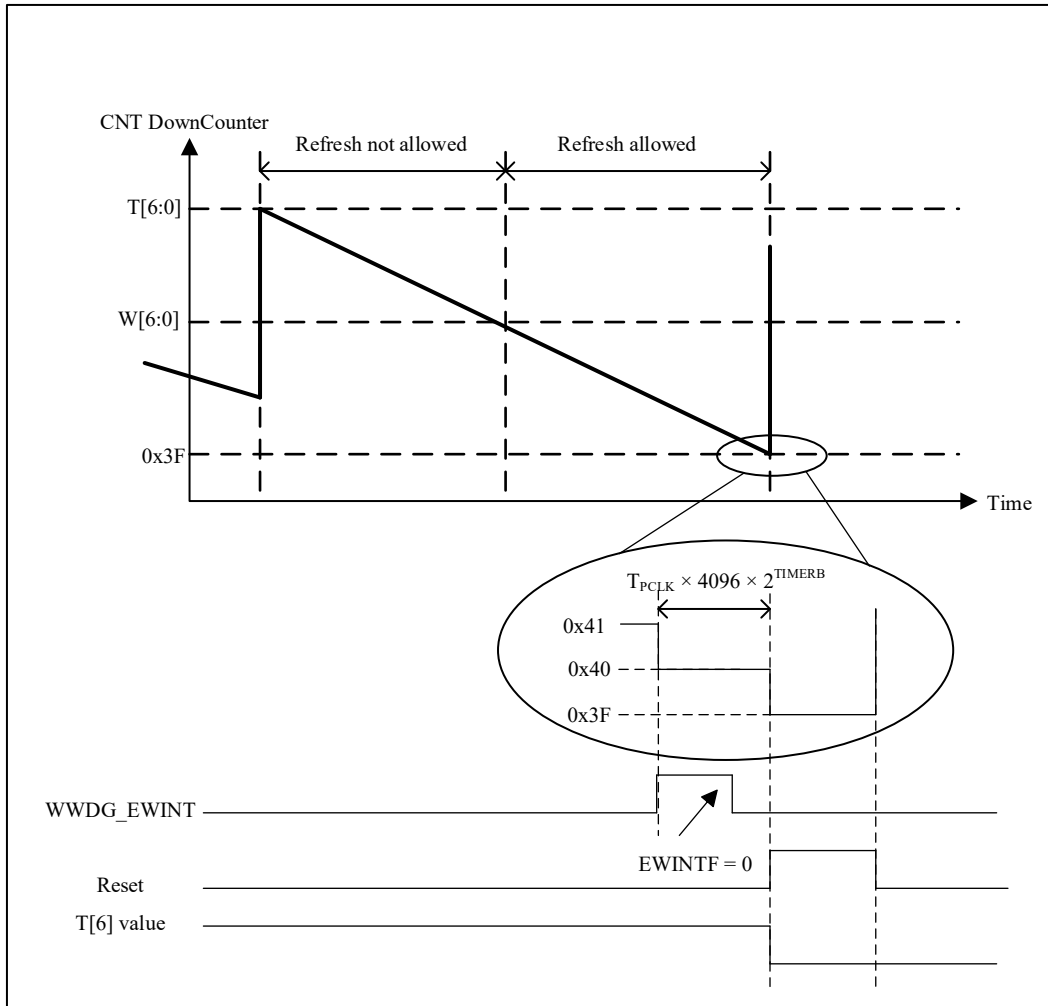
Set the WWDG\_CTRL.ACTB bit to enable the watchdog, and thereafter, the WWDG will remain operating until reset occurs. The 7-bit down-counter runs independently, and the counter keeps counting down whether WWDG is enabled or not. Therefore, before enabling the watchdog, you need to set WWDG\_CTRL.T [6] bit to 1 to prevent an immediate reset after enabling. The pre-scaler value set by the clock APB1 and WWDG\_CFG.TIMERB[1:0] bits determines the decrement speed of the counter. WWDG\_CFG.W[6:0] bits set the upper limit of the window.

When the down-counter is refreshed before reaching the window register value or after WWDG\_CTRL.T6 bit becomes 0, a system reset will be generated. Figure 14-2 describes the operating process of the window register.

Set the WWDG\_CFG.EWINT bit to enable early wake-up interrupt. When the count-down counter reaches 0x40, an interrupt will be triggered. You can analyze the cause of software failure or save important data in the corresponding interrupt service routine (ISR), and reload the counter to prevent WWDG from resetting. Write '0' to the WWDG\_STS.EWINTF bit to clear the interrupt.

### 14.4 Timing for Refresh Watchdog and Interrupt Generation

Figure 14-2 Refresh Window and Interrupt Timing of WWDG



Watchdog refreshing window is between WWDG\_CFG.W[6:0] value (maximum value 0x7F) and 0x3F, refreshing outside this window will generate reset request to MCU. Counter counts down from 0x7F to 0x3F using scaled APB1 clock, the maximum counting time and minimum counting time is shown in Table 14-1 (assuming APB1 clock 48 MHz) with calculate equation:

$$T_{WWDG} = T_{PCLK1} \times 4096 \times 2^{TIMERB} \times (T[5:0] + 1)$$

In which:

$T_{WWDG}$ : WWDG timeout

$T_{PCLK1}$ : APB1 clock interval in ms

Minimum-maximum timeout value at PCLK1 = 48MHz

**Table 14-1 Maximum and Minimum Counting Time of WWDG**

| TIMERB | Min Timeout Value( $\mu$ s)<br>T[5:0] = 0x00 | Max Timeout Value(ms)<br>T[5:0] = 0x3F |
|--------|--|--|
| 0      | 85.33  | 5.46                                   |
| 1      | 170.67                                       | 10.92                                  |
| 2      | 341.33                                       | 21.85                                  |
| 3      | 682.67                                       | 43.68                                  |

## 14.5 Debug Mode

In debug mode (Cortex<sup>®</sup>-M0 core stops), WWDG counter will either continue to operate normally or stop, depending on DBG\_CTRL.WWDG\_STOP bit in debug module. If this bit is set to ‘1’, the counter stops. If this bit is set to ‘0’, the counter operate normally. For details, refer to 3.3.2 Peripheral Debug Support.

## 14.6 User Interface

### 14.6.1 WWDG Configuration Flow

- 1) Configure RCC\_APB1PCLKEN.WWDGEN[11] bit to enable the clock of WWDG module.
- 2) Software sets WWDG\_CFG.TIMERB[8:7] bits to configure pre-scale factor for WWDG.
- 3) Software configures WWDG\_CTRL.T[6:0] bits and sets starting value of counter. To prevent immediate reset after enabling, the WWDG\_CTRL.T[6] bit is needed to set to 1.
- 4) Configure WWDG\_CFG.W[6:0] bits to configure upper boundary window value;
- 5) Set WWDG\_CTRL.ACTB[7] bit to enable WWDG;
- 6) Software operates WWDG\_STS.EWINTF[0] bit to clear wake-up interrupt flag;
- 7) Configure WWDG\_CFG.EWINT[9] bit to enable early wake-up interrupt.

## 14.7 WWDG Registers

### 14.7.1 WWDG Register Overview

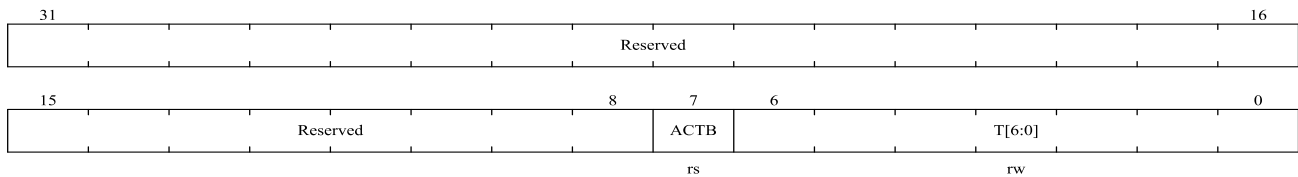
**Table 14-2 WWDG Register Overview**

| Offset | Register    | 31       | 30 | 29 | 28 | 27 | 26 | 25 | 24 | 23 | 22 | 21 | 20    | 19              | 18     | 17 | 16 | 15 | 14 | 13 | 12 | 11 | 10 | 9 | 8    | 7      | 6 | 5      | 4 | 3 | 2 | 1 | 0 |
|--------|-------------|----------|----|----|----|----|----|----|----|----|----|----|-------|-----------------|--------|----|----|----|----|----|----|----|----|---|------|--------|---|--------|---|---|---|---|---|
| 000h   | WWDG_CTRL   | Reserved |    |    |    |    |    |    |    |    |    |    |       |                 |        |    |    |    |    |    |    |    |    |   | ACTB | T[6:0] |   |        |   |   |   |   |   |
|        | Reset Value |          |    |    |    |    |    |    |    |    |    |    |       |                 |        |    |    |    |    |    |    |    |    |   |      | 0      | 1 | 1      | 1 | 1 | 1 | 1 | 1 |
| 004h   | WWDG_CFG    | Reserved |    |    |    |    |    |    |    |    |    |    | EWINT | TIMERB<br>[1:0] | W[6:0] |    |    |    |    |    |    |    |    |   |      |        |   |        |   |   |   |   |   |
|        | Reset Value |          |    |    |    |    |    |    |    |    |    |    |       |                 | 0      | 0  | 0  | 1  | 1  | 1  | 1  | 1  | 1  | 1 |      |        |   |        |   |   |   |   |   |
| 008h   | WWDG_STS    | Reserved |    |    |    |    |    |    |    |    |    |    |       |                 |        |    |    |    |    |    |    |    |    |   |      |        |   | EWINTF |   |   |   |   |   |
|        | Reset Value |          |    |    |    |    |    |    |    |    |    |    |       |                 |        |    |    |    |    |    |    |    |    |   |      |        |   |        | 0 |   |   |   |   |

### 14.7.2 WWDG Control Register (WWDG\_CTRL)

Address offset : 0x00

Reset value : 0x0000007F

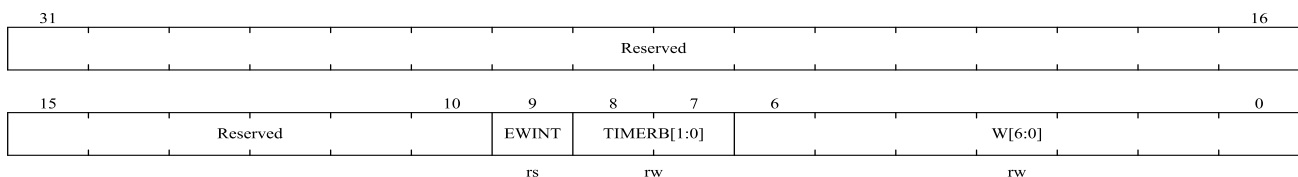


| Bit Field | Name     | Description  |
|-----------|----------|--|
| 31:8      | Reserved | Reserved, the reset value must be maintained.  |
| 7         | ACTB     | Activation bit<br>When ACTB=1, the watchdog can generate a reset. This bit is set by software and only cleared by hardware after a reset. When ACTB = 1, the watchdog can generate a reset.<br>0: Disable watchdog<br>1: Enable watchdog |
| 6:0       | T[13:0]  | These bits contain the value of the watchdog counter. It is decremented every $(4096 \times 2^{\text{TIMERB}})$ PCLK1 cycles. A reset is produced when it rolls over from 0x40 to 0x3F (T6 becomes cleared).                             |

### 14.7.3 WWDG Config Register (WWDG\_CFG)

Address offset: 0x04

Reset value : 0x0000007F



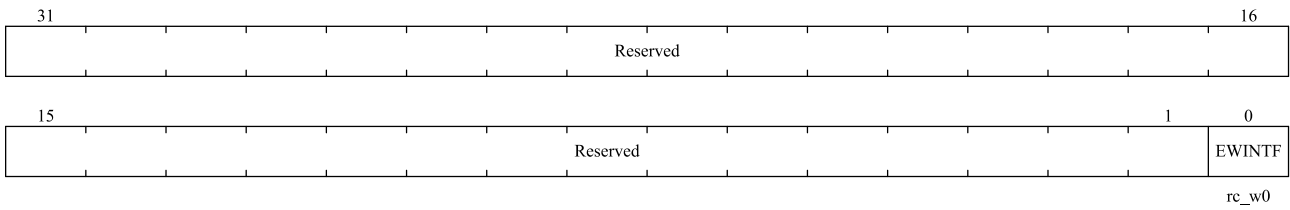
| Bit Field | Name        | Description  |
|-----------|-------------|--|
| 31:10     | Reserved    | Reserved, the reset value must be maintained.  |
| 9         | EWINT       | Early wake-up interrupt<br>When set, an interrupt occurs whenever the counter reaches the value 0x40. This interrupt is only cleared by hardware after a reset.  |
| 8:7       | TIMERB[1:0] | Timer base.<br>The time base of the pre-scaler can be modified as follows:<br>00: CK Counter Clock (PCLK1 div 4096) div 1<br>01: CK Counter Clock (PCLK1 div 4096) div 2<br>10: CK Counter Clock (PCLK1 div 4096) div 4<br>11: CK Counter Clock (PCLK1 div 4096) div 8 |
| 6:0       | W[6:0]      | 7-bit window value<br>These bits contain the window value to be compared to the down counter.  |



**14.7.4 WWDG Status Register (WWDG\_STS)**

Address offset: 0x08

Reset value : 0x0000



| Bit Field | Name     | Description   |
|-----------|----------|---|
| 31:1      | Reserved | Reserved, the reset value must be maintained.   |
| 0         | EWINTF   | Early wake-up interrupt flag<br>This bit is set by hardware when the counter has reached the value 0x40. It must be cleared by software by writing '0'. A write of '1' has no effect. This bit is also set if the interrupt is not enabled. |

## 15 Analog to Digital Conversion (ADC)

### 15.1 Introduction

The 12-bit ADC is a high-speed analog-to-digital converter using successive approximation. It has 16 channels, which can measure 12 external and 4 internal signal sources. The A/D conversion of each channel has four execution modes: single, continuous, scan and discontinuous. The ADC measurement values are stored (left-aligned/ right-aligned) in 16-bit data registers. The ADC can detect if the input voltage is within user-defined high/low thresholds by analog watchdog, and the maximum frequency of the input clock to the ADC is 18MHz.

The ADC injection sampling channel supports automatic switching of the positive input of the OPA.

### 15.2 Main Features

- Supports 12-bit resolution, the maximum sampling rate is 1Msps
- ADC clock source is divided into operating clock source, sampling clock source and timing clock source
  - AHB\_CLK can be configured as the operating clock source, up to 48MHz
  - PLL can be configured as a sampling clock source, up to 18MHz, supports 1,2,3,4,6,8,10,12,16,32, 64,128,256 frequency division
  - The AHB\_CLK can be configured as the sampling clock source, up to 18MHz, and supports frequency 1,2,3,4,6,8,10,12,16,32
  - The timing clock is used for internal timing functions and the frequency must be configured to 1MHz
- Supports timer trigger ADC sampling
- Interrupts when conversion ends, injection conversion ends, and analog watchdog events occur
- Single and continuous conversion modes
- Automatic scan mode from channel 0 to channel N
- Data alignment with embedded data consistency
- Sampling intervals can be programmed separately by channel
- Both regular conversions and injection conversions have external triggering options
- Discontinuous mode
- ADC power supply requirements: 2.4V to 5.5V
- ADC input range:  $0 \leq V_{IN} \leq V_{DDA}$
- ADC can use DMA operations, and DMA requests are generated during regular channel conversion.

### 15.3 Function Description

Figure 15-1 is a functional block diagram of an ADC.

Figure 15-1 Block Diagram of A Single ADC

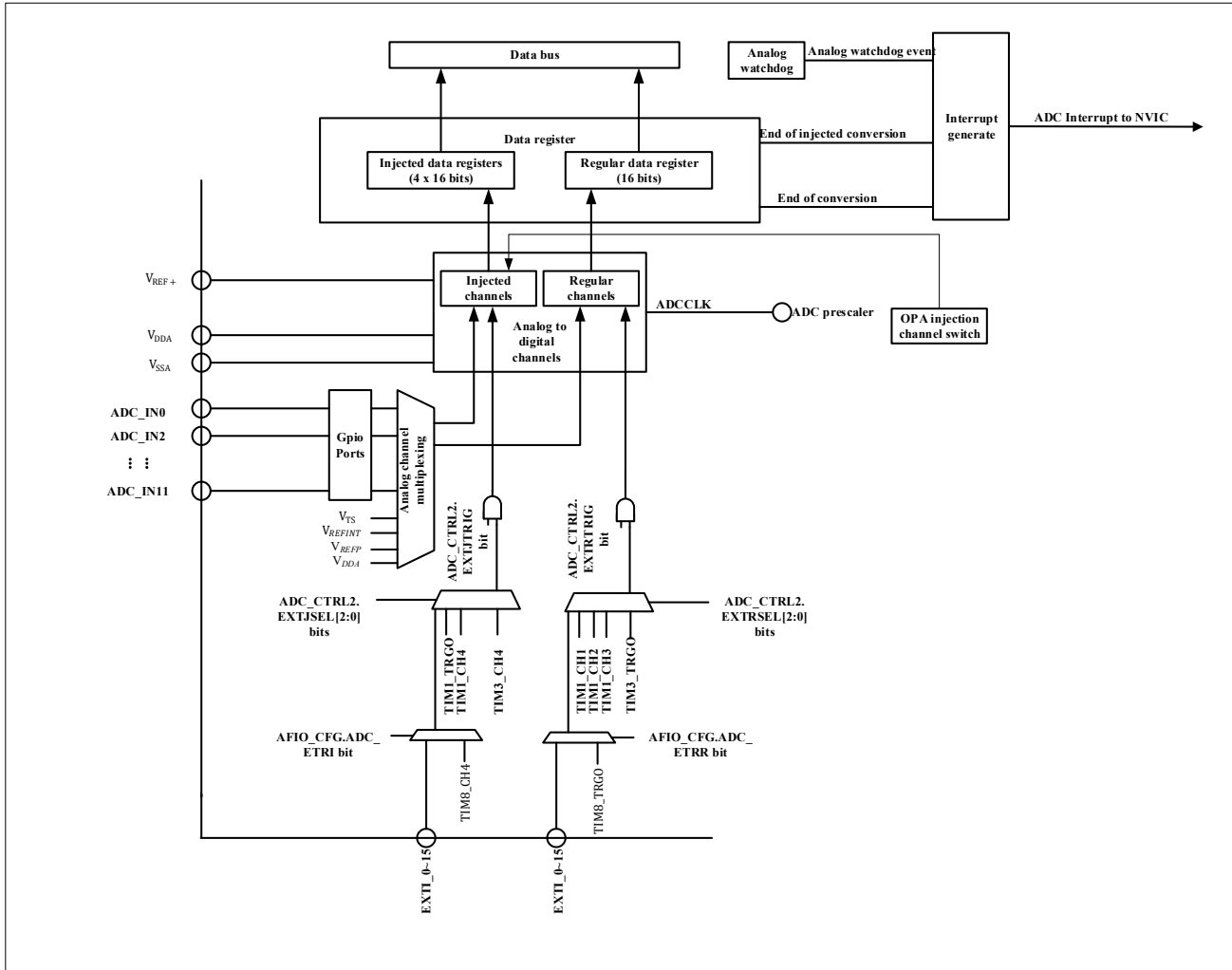


Table 15-1 ADC Pins

| Name                       | Signal Types                      | Annotations   |
|----------------------------|-----------------------------------|---|
| V <sub>DDA</sub>           | Input, analog power supply        | Equivalent to V <sub>DD</sub> analog power supply and: 1.8V ≤ V <sub>DDA</sub> ≤ V <sub>DD</sub> (5.5V) |
| V <sub>SSA</sub>           | Input, analog power supply ground | Equivalent to V <sub>SS</sub> Analog power supply ground  |
| V <sub>REF+</sub>          | Input, analog reference positive  | Positive reference voltage used by ADC, 2.4V ≤ V <sub>REF+</sub> ≤ V <sub>DDA</sub>                     |
| ADC <sub>x</sub> _IN[11:0] | Analog input signal               | 12 analog external input channels   |

Note: V<sub>DDA</sub> and V<sub>SSA</sub>. They should be separately connected to V<sub>DD</sub> and V<sub>SS</sub>.

### 15.3.1 ADC Clock

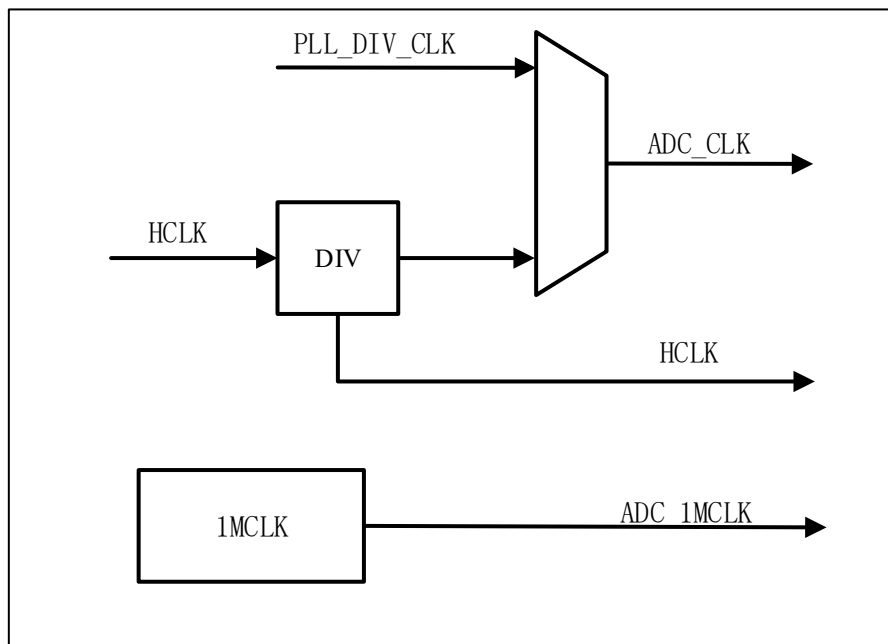
An ADC requires three clocks, HCLK, ADC\_CLK and ADC\_1MCLK.

- HCLK is used for the register access.
- ADC\_CLK is the operating clock of ADC. ADC\_CLK has two sources (divided from HCLK or PLL). The divided clock from HCLK and system clock are synchronous clock, while the divided clock from PLL and system are asynchronous clock. The advantage of using a synchronous clock is that there is no uncertainty when triggering the ADC to respond to the trigger. The advantage of using PLL's divider clock is that the ADC's operating clock can be handled independently without affecting other modules attached to the HCLK
- ADC\_1MCLK for internal timing function, configured in RCC, frequency size must be configured to 1MHz

Note:

- (1) When configuring PLL as a clock source, the maximum frequency can reach 18MHz, supporting division factors of 1,2,3,4,6,8,10,12,16,32,64,128,256
- (2) The AHB\_CLK frequency division can be configured as a operating clock up to 18MHz. The AHB\_CLK frequency division can be 1,2,3,4,6,8,10,12,16,32
- (3) When switching the ADC\_1M clock source, make sure that the HSI clock is enabled.

Figure 15-2 ADC Clock



### 15.3.2 ADC Switch Control

You can proceed to the next step only after the power-up process is complete. You can check if the power-up is complete by polling the ADC\_CTRL3.RDY bit.

You can set the ADC\_CTRL2.ON bit to turn on the ADC. When the ADC\_CTRL2.ON bit is set for the first time, it wakes

up the ADC from the power-off state. After a power-on delay of ADC ( $t_{STAB}$ ), and the conversion begins when the ADC\_CTRL2.ON bit is set again.

The conversion can be stopped by clearing the ADC\_CTRL2.ON bit to configure the ADC in power-down mode. In this mode, the ADC consumes almost no power (just a few  $\mu A$ ). Power-down mode can be checked by polling the ADC\_CTRL3.PDRDY bit.

When the ADC is disabled, the default mode is power-down.

### 15.3.3 Channel Selection

Each channel can be configured as a regular sequence and an injection sequence. The injection sequence consists of multiple conversions, up to a maximum of 4. The ADC\_JSEQ register specifies the injection channel and the conversion order of the injection channel. The ADC\_JSEQ.JLEN[21:20] bits specify injection sequence length.

The regular sequence consists of multiple conversions, up to a maximum of 16. The ADC\_RSEQx registers specify the regular channels and the conversion order of the regular channels. The ADC\_RSEQ1.LEN[23:20] bits specify regular channel sequence length.

*Note: During conversion, changes to the ADC\_RSEQx or ADC\_JSEQ registers are prohibited; the ADC\_RSEQx or ADC\_JSEQ registers can only be changed when the ADC is idle.*

### 15.3.4 Internal Channel

- The temperature sensor connects to channel ADC\_IN12
- The internal reference voltage  $V_{REFINT}$  is connected to the channel ADC\_IN13
- Internal reference voltage  $V_{REFP}$  is connected to channel ADC\_IN14
- VDDA pin voltage is connected to channel ADC\_IN15
- ADC\_IN6 can be connected to internal OPAMP\_OUT besides IO

Internal channels can be converted by injection or regular channels.

*Note:  $V_{REFINT}$  needs to be enabled by configuring ADC\_CTRL3.VREFEN. After enabling, it is necessary to confirm that  $V_{REFINT}$  is ready by ADC\_CTRL3.VREFRDY.*

### 15.3.5 Single Conversion Mode

The ADC can enter the single conversion mode by configuring ADC\_CTRL2.CTU to 0. In this mode, external triggering (for regular channels or injection channels) or setting ADC\_CTRL2.ON=1 (for regular channels only) can start the ADC to start conversion, and the ADC only performs one conversion.

After the conversion starts, when an injection channel conversion is completed, the injection channel conversion end flag (ADC\_STS.JENDC) will be set to 1. If the injection channel conversion end interrupt enable (ADC\_CTRL1.JENDCIEN) bit is set to 1, an interrupt will be triggered at this time, and the converted data will be stored in the ADC\_JDATx register.

After the conversion starts, when a regular channel conversion is completed, the regular channel conversion end flag (ADC\_STS.ENDC) will be set to 1. If the regular channel conversion end interrupt enable (ADC\_CTRL1.ENDCIEN) bit is set to 1, an interrupt will be triggered at this time, and the converted data will be stored in the ADC\_DAT register.

After single conversion, the ADC stops.

### 15.3.6 Continuous Conversion Mode

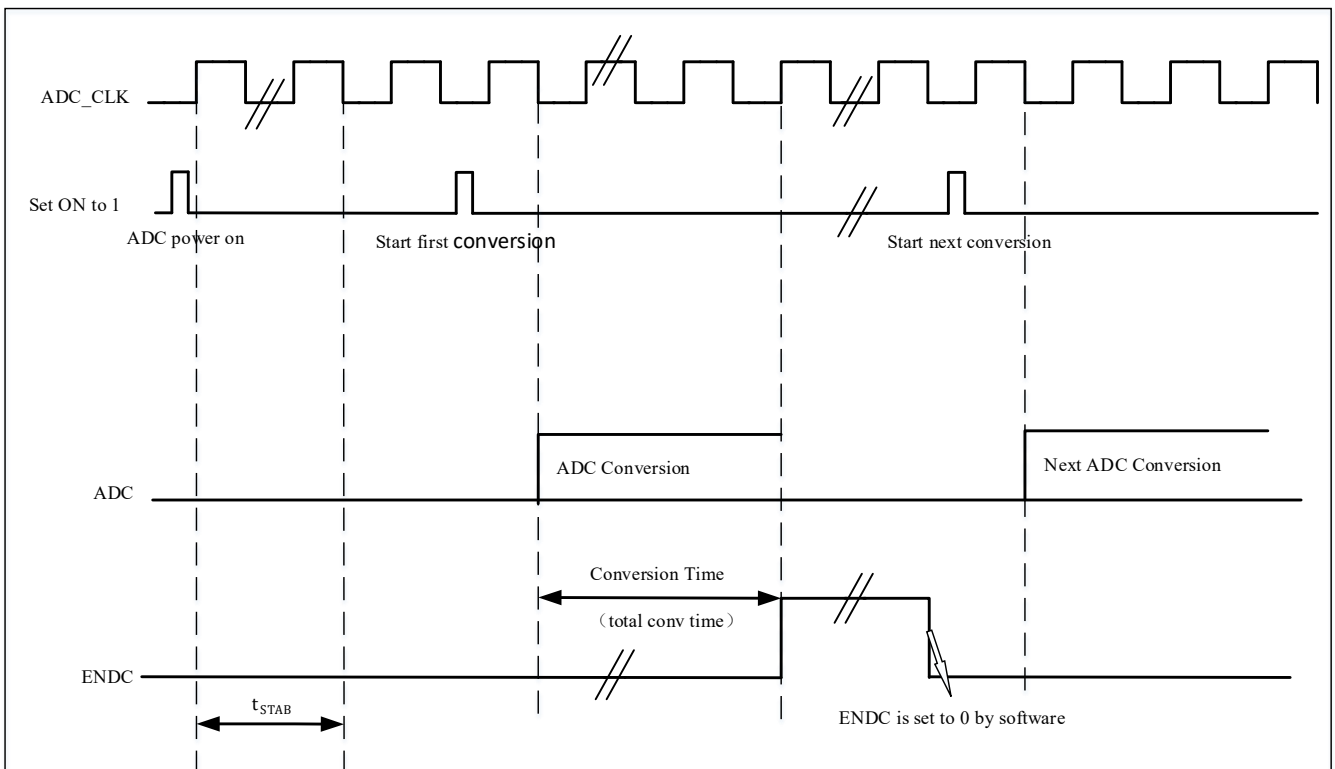
The ADC can enter the continuous conversion mode by configuring ADC\_CTRL2.CTU to 1. In this mode, external triggering or setting ADC\_CTRL2.ON to 1 can start the ADC to start conversion, and the ADC will continuously convert the selected channel. Continuous mode is only valid for regular channels, not for injection channels.

After the conversion starts, when a regular channel conversion is completed, the regular channel end of conversion flag bit (ADC\_STS.ENDC) will be set to 1. If the regular channel conversion end interrupt enable bit (ADC\_CTRL1.ENDCIEN) is set to 1 at this time, an interrupt will be triggered. The converted data will be stored in the ADC\_DAT register.

### 15.3.7 Timing Diagram

When ADC\_CTRL2.ON is set to 1 for the first time, the ADC is powered on. After the ADC is powered on, the ADC needs a certain time ( $t_{STAB}$ ) to ensure its stability. After the ADC is stabilized, write 1 to ADC\_CTRL2.ON again, and the ADC starts conversion. The end of conversion flag will be set to 1 after the conversion is completed.

Figure 15-3 Timing Diagram



### 15.3.8 Analog Watchdog

The analog watchdog can be enabled on the regular channel by setting ADC\_CTRL1.AWDGERCH to 1, or the analog watchdog on the injection channel can be enabled by setting ADC\_CTRL1.AWDGEJCH to 1. The high threshold of the analog watchdog can be set by configuring ADC\_WDGHIGH.HTH, and the low threshold of the analog watchdog can be set by configuring ADC\_WDGLOW.LTH. The threshold of the analog watchdog and the way of data alignment is irrelevant, because the comparison of the ADC's conversion value with the threshold is done before the alignment. When the value of ADC analog conversion is higher than the high threshold of the analog watchdog or lower than the low threshold of the

analog watchdog, the analog watchdog flag (ADC\_STS.AWDG) will be set to 1, if ADC\_CTRL1.AWDGIEN has been configured to 1, an interrupt will be triggered at this time. The analog watchdog can be controlled to operate on one or multiple channels by configuring ADC\_CTRL1.AWSGSGLEN and ADC\_CTRL1.AWDGCH[3:0], as shown in Table 15-2.

**Table 15-2 Analog Watchdog Channel Selection**

| Channel                               | ADC_CTRL1 Register Control Bit |          |          |
|---------------------------------------|--------------------------------|----------|----------|
|                                       | AWDGSGLN                       | AWDGERCH | AWDGEJCH |
| There is none                         | Any value                      | 0        | 0        |
| All injection channels                | 0                              | 0        | 1        |
| All regular channels                  | 0                              | 1        | 0        |
| All injection and regular channels    | 0                              | 1        | 1        |
| A single injection channel            | 1                              | 0        | 1        |
| A single regulars of the channel      | 1                              | 1        | 0        |
| A single injection or regular channel | 1                              | 1        | 1        |

### 15.3.9 Scan Mode

By configuring ADC\_CTRL1.SCAMD to 1, the scan conversion mode can be turned on, and by configuring the four registers ADC\_RSEQ1, ADC\_RSEQ2, ADC\_RSEQ3, ADC\_JSEQ, the conversion sequence can be selected, and the ADC will scan and convert all the selected channels. After the conversion is started, the channels will be converted one by one. If ADC\_CTRL2.CTU is 1 at this time, the conversion will be restarted from the first channel of the conversion sequence after the conversion of all selected channels is completed. The DMA function can be turned on by setting ADC\_CTRL2.ENDMA to 1, and the DMA will transfer the data to the SRAM after the regular channel conversion is completed.

### 15.3.10 Injection Channel Management

#### 15.3.10.1 Automatic injection

If ADC\_CTRL1.AUTOJC bit is set, then the injected channels selected by ADC\_JSEQ<sub>x</sub> will automatically convert after the regular channels selected by ADC\_RSEQ<sub>x</sub> have completed conversion. A single trigger can convert up to 16+4 channels. Setting ADC\_CTRL2.CTU the conversion sequence will be converted continuously.

When this function is turned on, the external trigger of the injection channel needs to be turned off.

This function cannot be used with the discontinuous mode at the same time.

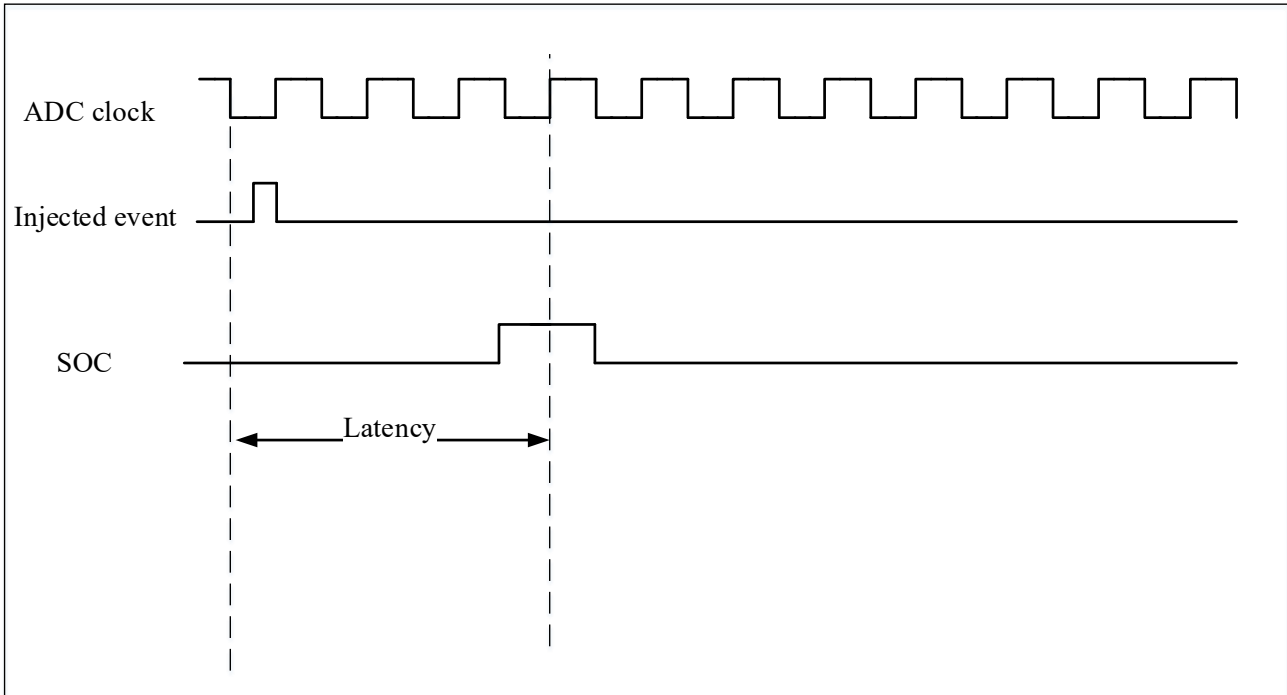
When the ADC clock prescale factor is 2, there is a delay of two ADC clock intervals when the conversion sequence changes from regular to injection or injection to regular. When the ADC clock prescale factor is from 4 to 8, there is a delay of one ADC clock intervals when the conversion sequence changes from regular to injection or injection to regular.

#### 15.3.10.2 Trigger injection

Set ADC\_CTRL1.AUTOJC to 0 and ADC\_CTRL1.SCAMD to 1 to enable the trigger injection function. In this function, the conversion on regular channels either by setting the ADC\_CTRL2.ON or by external trigger in continuous mode. When the regular channel is converted, if an external injection trigger is generated, the current conversion will be suspended, and the injection sequence channel will start conversion. When the injection sequence channel conversion is completed, the

interrupted conversion of regular sequence channel will be resumed. If a regular event is generated during the injection conversion, the regular sequence channel will start conversion after the injection sequence channel conversion is completed. When using this feature, the time interval of injected channel triggers needs to be greater than the time it takes for the injection sequence to complete the transition.

**Figure 15-4 Injection Conversion Delay**



*Note: For the maximum delay value, please refer to the electrical characteristics section in the data manual.*

**15.3.11 Discontinuous Mode**

**15.3.11.1 Regular channels**

Configure ADC\_CTRL1.DREGCH to 1 to enable the discontinuous mode on the regular channel, obtain the regular sequence by configuring ADC\_RSEQ1, ADC\_RSEQ2, ADC\_RSEQ3, and configure ADC\_CTRL1.DCTU[2:0] to control the conversion of n channels after each trigger.

When the trigger signal is generated, the ADC will convert n channels of the regular sequence and then stop until the next trigger signal is generated. It will continue to convert n channels from the point where the previous conversion stopped, until all channels of the regular sequence are converted (if the last trigger occurs and the remaining channels in the conversion sequence are less than n, only the remaining channels will be converted and the conversion will be stopped). The end of conversion flag bit will also be set to 1. When the conversion of all channels in the conversion sequence is completed, the next trigger signal occurs, and the conversion will start from the first channel of the regular sequence again.

**15.3.11.2 Injection channels**

Configure ADC\_CTRL1.DJCH to 1 to enable the discontinuous mode on the injection channel, obtain the injection sequence by configuring ADC\_JSEQ.



When the trigger signal is generated, the ADC will convert 1 channel of the injection sequence and then stop until the next trigger signal is generated. It will continue to convert 1 channel from the point where the previous conversion stopped until all channels of the injection sequence are converted, and the end of conversion flag bit will also be set to 1. When the conversion of all channels in the conversion sequence is completed, the next trigger signal occurs, and the conversion will start from the first channel of the injection sequence again.

Only one of injection conversion and regular conversion can be set to discontinuous mode at the same time, and the automatic injection function and discontinuous mode cannot be set at the same time.

### 15.4 Data Aligned

There are two alignment methods for data memory after conversion: left-aligned and right-aligned. The alignment can be set by the ADC\_CTRL2.ALIG bit. ADC\_CTRL2.ALIG = 0 is right-aligned, as shown in Table 15-3, ADC\_CTRL2.ALIG = 1 is left-aligned, as shown in Table 15-4.

For injection sequence, the SYM bit is the extended sign value, and the data stored in the register is the conversion result minus the user-defined offset in the ADC\_JOFFSETx register, so the result can be a negative value; for regular sequence, there is no need to subtract offset value.

**Table 15-3 Right-align Data**

The Injection sequence

|     |     |     |     |     |     |    |    |    |    |    |    |    |    |    |    |
|-----|-----|-----|-----|-----|-----|----|----|----|----|----|----|----|----|----|----|
| SYM | SYM | SYM | SYM | D11 | D10 | D9 | D8 | D7 | D6 | D5 | D4 | D3 | D2 | D1 | D0 |
|-----|-----|-----|-----|-----|-----|----|----|----|----|----|----|----|----|----|----|

The regular sequence

|   |   |   |   |     |     |    |    |    |    |    |    |    |    |    |    |
|---|---|---|---|-----|-----|----|----|----|----|----|----|----|----|----|----|
| 0 | 0 | 0 | 0 | D11 | D10 | D9 | D8 | D7 | D6 | D5 | D4 | D3 | D2 | D1 | D0 |
|---|---|---|---|-----|-----|----|----|----|----|----|----|----|----|----|----|

**Table 15-4 Left-align Data**

Injection sequence

|     |     |     |    |    |    |    |    |    |    |    |    |    |   |   |   |
|-----|-----|-----|----|----|----|----|----|----|----|----|----|----|---|---|---|
| SYM | D11 | D10 | D9 | D8 | D7 | D6 | D5 | D4 | D3 | D2 | D1 | D0 | 0 | 0 | 0 |
|-----|-----|-----|----|----|----|----|----|----|----|----|----|----|---|---|---|

The regular sequence

|     |     |    |    |    |    |    |    |    |    |    |    |   |   |   |   |
|-----|-----|----|----|----|----|----|----|----|----|----|----|---|---|---|---|
| D11 | D10 | D9 | D8 | D7 | D6 | D5 | D4 | D3 | D2 | D1 | D0 | 0 | 0 | 0 | 0 |
|-----|-----|----|----|----|----|----|----|----|----|----|----|---|---|---|---|

### 15.5 Programmable Channel Sampling Time

The ADC samples the input voltage over several ADC\_CLK cycles, and the number of sampling periods can be changed through ADC\_SAMPTx.SAMPx[2:0]. Each channel can be sampled with different times. The total conversion time is calculated as follows:

$$T_{CONV} = \text{Sampling time} + 12 \text{ cycles}$$

Example:

ADCCLK=16MHz, the sampling time is 6 cycles,the total conversion time is "6 + 12" ADCCLK Cycles, that is:

$$T_{CONV} = 6 + 12 = 18 \text{ cycle} = 1.125\mu\text{s}$$

## 15.6 Externally Triggered Conversion

For the regular sequence , software sets the ADC\_CTRL2.EXTRTRIG bit to 1, then the regular channel can use the rising edge of the external event to trigger the start conversion, and then the software sets the ADC\_CTRL2.EXTRSEL[2:0] bits to select the external trigger source of the regular sequence. The external trigger source selection is shown in the table below. If you select EXTI line 0~15 or TIM8\_TRGO as the external trigger source, you can set the AFIO\_CFG.ADC\_ETRR and AFIO\_CFG.EXTI\_ETRR[3:0] bits to implement; if you select SWSTRRCH as the external trigger source, you can start the regular channel conversion by setting ADC\_CTRL2.SWSTRRCH to 1.

**Table 15-5 ADC is Used for External Triggering of Regular Channels**

| EXTRSEL[2:0] | Trigger Source                 | Type  |
|--------------|--------------------------------|---|
| 000          | TIM1_CC1 event                 | Internal signal from the on-chip timer          |
| 001          | TIM1_CC2 event                 |   |
| 010          | TIM1_CC3 event                 |   |
| 011          | N/A                            |   |
| 100          | TIM3_TRGO event                |   |
| 101          | N/A                            |   |
| 110          | EXTI line 0~15/TIM8_TRGO event | External pin/internal signal from on-chip timer |
| 111          | SWSTRRCH                       | Software control bit                            |

For the injection sequence , the software sets the ADC\_CTRL2.EXTJTRIG bit to 1, then the injection channel can use the rising edge of the external event to trigger the start conversion, and the software sets the ADC\_CTRL2.EXTJSEL[2:0] bits to select the external trigger source of the injection sequence. The external trigger source selection is shown in the table below. If you select EXTI line 0~15 or TIM8\_CC4 as the external trigger source, you can set the AFIO\_CFG.ADC\_ETRI and AFIO\_CFG.EXTI\_ETRI[3:0] bits to implement; if you select SWSTRJCH as the external trigger source, you can start the injection channel conversion by setting ADC\_CTRL2.SWSTRJCH to 1.

**Table 15-6 ADC Is Used for External Triggering of Injection Channels**

| EXTJSEL[2:0] | Trigger Source                | Type  |
|--------------|-------------------------------|---|
| 000          | TIM1_TRGO event               | Internal signal from the on-chip timer          |
| 001          | TIM1_CC4 event                |   |
| 010          | N/A                           |   |
| 011          | N/A                           |   |
| 100          | TIM3_CC4 event                |   |
| 101          | N/A                           |   |
| 110          | EXTI line 0~15/TIM8_CC4 event | External pin/internal signal from on-chip timer |
| 111          | SWSTRJCH                      | Software control bit                            |

*Note: Injection triggers can interrupt conversion of the regular sequence.*

### 15.7 DMA Requests

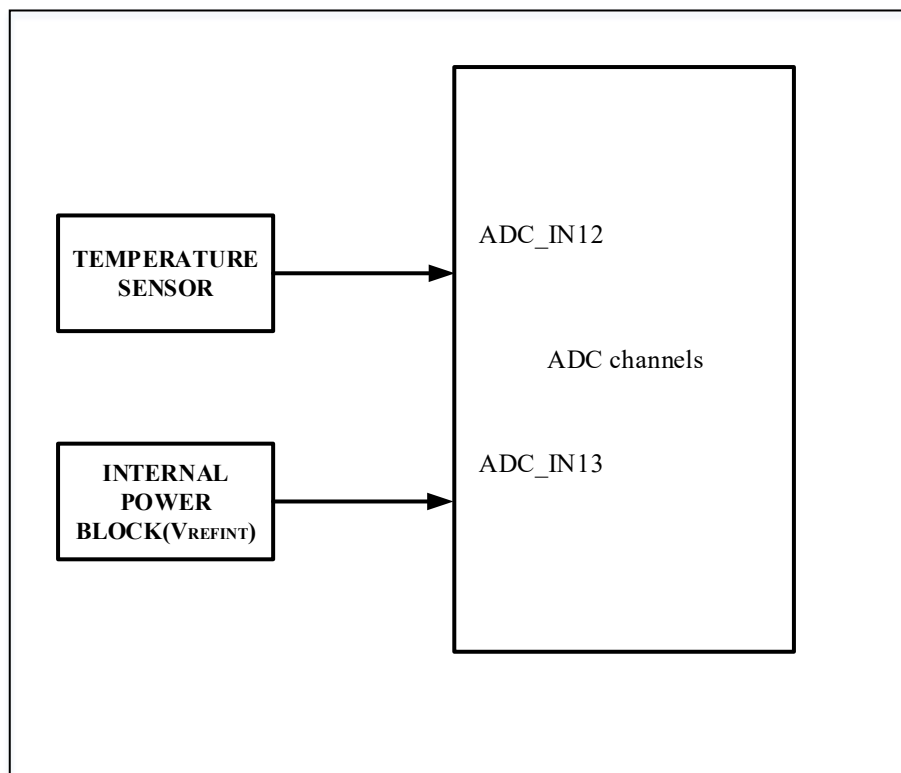
In order to avoid losing the results of regular channel conversions stored in the ADC\_DAT register due to excessive data during multiple regular channel conversions, you can set the ADC\_CTRL2.ENDDMA bit to 1 to use the DMA. When the ADC regular channel conversion ends, a DMA request is generated. After receiving the request, the DMA will transfer the converted data from the ADC\_DAT register to the destination address specified by the user.

### 15.8 Temperature Sensor

Set the ADC\_CTRL2.TEMPEN bit to 1, enable the temperature sensor, and use the temperature sensor to detect the ambient temperature when the device is operating. The output voltage sampled by the temperature sensor is converted to a digital value by the ADC\_IN12 channel. When the temperature sensor is operating, the recommended sampling time is 17.1us; when the temperature sensor is not operating, the ADC\_CTRL2.TEMPEN bit can be cleared by software to turn off the temperature sensor to reduce power consumption. Figure 15-5 is a block diagram of a temperature sensor.

The output voltage of the temperature sensor changes linearly with temperature. Different chips will have different offsets in the temperature curve due to different production processes. Through testing, it is found that the maximum offset is 3°C. This characteristic makes the internal temperature sensor more suitable for detecting temperature changes, rather than for measuring absolute temperature. When accurate temperature measurement is required, an external temperature sensor should be used.

**Figure 15-5 Temperature Sensor and V<sub>REFINT</sub> Diagram of The Channel**



### 15.8.1 Temperature Sensor Using Flow

- 1) Configure the channel (ADC\_IN12) and sampling time as 17.1us
- 2) Set ADC\_CTRL2.TEMPEN bit to 1 to enable temperature sensor
- 3) Set ADC\_CTRL2.ON bit to 1 to start ADC conversion (or through external trigger)
- 4) Read the temperature data in the ADC data register, and calculate the temperature value by the following formula:

$$\text{Temperature (}^\circ\text{C)} = \{(V_{25} - V_{\text{SENSE}}) / \text{Avg\_Slope}\} + 25$$

In which:

$V_{25} = V_{\text{SENSE}}$  at 25 degrees Celsius

Avg\_Slope = temperature and  $V_{\text{SENSE}}$  Average slope of a curve (mV/°C or  $\mu\text{V}/^\circ\text{C}$ )

Refer to the values of  $V_{25}$  and Avg\_Slope in the electrical characteristics chapter of the datasheet.

*Note: There is a settling time before the sensor wakes up from the power-off mode to the correct output of VSENSE; there is also a settling time after the ADC is powered on, so in order to shorten the delay, the ADC\_CTRL2.TEMPEN and ADC\_CTRL2.ON bits should be set at the same time.*

### 15.9 ADC Interrupt

ADC interrupts can be triggered by an end of regular or injection sequence conversion, an analog watchdog event when input voltage exceeds the threshold, any end of regular or injection channel conversion. These interrupts have independent interrupt enable bits.

There are 2 status flags in the ADC\_STS register: injection sequence channel conversion started (JSTR) and regular sequence channel conversion started (STR). But there are no interrupts associated with these two flags in the ADC.

**Table 15-7 ADC Interrupt**

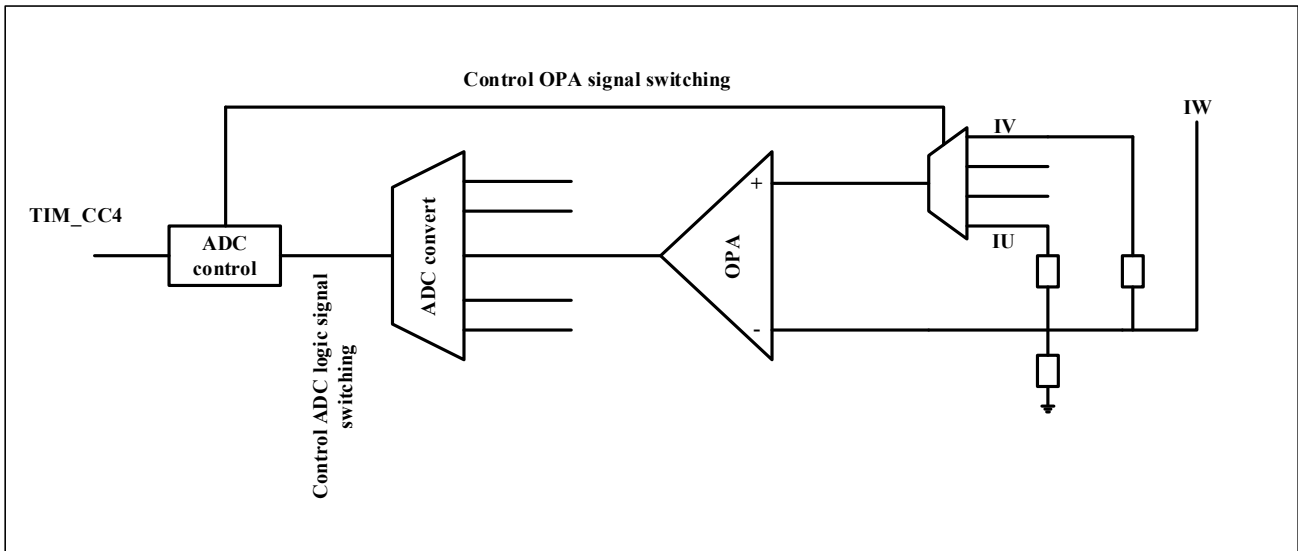
| Interrupt Event                                      | Event Flags | Enable Control Bit |
|--|-------------|--------------------|
| Regular sequence or injection conversion is complete | ENDC        | ENDCIEN            |
| Injection sequence conversion is complete            | JENDC       | JENDCIEN           |
| Analog watchdog status bit is set                    | AWDG        | AWDGIEN            |
| Any regular channel interruption is enabled          | ENDCA       | ENDCAIEN           |
| Any injection channel interruption is enabled        | JENDCA      | JENDCAIEN          |

### 15.10 OPA Channel Control

**Figure 15-6** is a schematic block diagram of ADC switching OPA channel. Before sampling the injection channel, the ADC\_OPACTRL register will control the OPA positive channel selection signal, wait for the OPA setup time, and then start sampling. When the sampling is completed, the ADC\_OPACTRL register release the channel control of the OPA.

**Figure 15-6** shows TIM1\_CC4 as the trigger, but the actual trigger source is not limited to TIM1\_CC4, all trigger sources are supported.

Figure 15-6 TIM1 CC4 Triggers OPA Channel Switching ADC Injection Sampling



The ADC\_OPACTRL.JSQx\_OPAEN register and ADC\_JSEQ.JLEN[1:0] can be used together to select which of the 4 samples enables the control of the OPA channel. Software can select the OPA channel corresponding to each sample by setting the ADC\_OPACTRL.JSQ1\_OPASEL, ADC\_OPACTRL.JSQ2\_OPASEL, ADC\_OPACTRL.JSQ3\_OPASEL and ADC\_OPACTRL.JSQ4\_OPASEL.

As shown in Table 15-8, if ADC\_JSEQ.JLEN[1:0] = 0, only the channel corresponding to JSQ4 is sampled, ADC\_OPACTRL.JSQ4\_OPAEN = 1 enables the control of the OPA input, and switches OPAMP\_CS.VPSEL = JSQ4\_OPASEL. If ADC\_JSEQ.JLEN[1:0] = 1, the JSQ3 channel is first converted, ADC\_OPACTRL.JSQ3\_OPAEN = 1 switches OPAMP\_CS.VPSEL = ADC\_OPACTRL.JSQ3\_OPASEL, then the JSQ4 channel is converted, and ADC\_OPACTRL.JSQ4\_OPAEN = 1 switches OPAMP\_CS.VPSEL = JSQ4\_OPASEL. ADC\_OPACTRL.JSQ3\_OPASEL.

Table 15-8 OPA Channel Selection

| LEN | 1st conv | 2nd conv | 3rd conv | 4th conv |
|-----|----------|----------|----------|----------|
| 0   | JSQ4     | -        | -        | -        |
| 1   | JSQ3     | JSQ4     | -        | -        |
| 2   | JSQ2     | JSQ3     | JSQ4     | -        |
| 3   | JSQ1     | JSQ2     | JSQ3     | JSQ4     |

Since the OPA channel needs a certain setup time after switching, the software can configure the ADC\_OPACTRL.OPA\_SETUP\_TIME. After switching the OPA channel, the ADC will wait for the corresponding setup time before starting sampling. The setup time is calculated as follows:

$$T = \text{ADC\_OPACTRL.OPA\_SETUP\_TIME} / \text{adc clock frequency.}$$

If ADC clock frequency=16MHz, the setup time is 5us, then OPA\_SETUP\_TIME=80 should be set.

## 15.11 ADC Registers

### 15.11.1 ADC Register Overview

**Table 15-9 ADC Register Overview**

| Offset | Register     | 31          | 30         | 29 | 28          | 27       | 26         | 25          | 24 | 23       | 22          | 21        | 20       | 19          | 18        | 17           | 16               | 15       | 14        | 13           | 12   | 11       | 10         | 9          | 8      | 7        | 6         | 5          | 4        | 3     | 2            | 1    | 0  |   |   |   |   |   |   |   |   |   |   |   |   |   |
|--------|--------------|-------------|------------|----|-------------|----------|------------|-------------|----|----------|-------------|-----------|----------|-------------|-----------|--------------|------------------|----------|-----------|--------------|------|----------|------------|------------|--------|----------|-----------|------------|----------|-------|--------------|------|----|---|---|---|---|---|---|---|---|---|---|---|---|---|
| 000h   | ADC_STS      | Reserved    |            |    |             |          |            |             |    |          |             |           |          |             |           |              |                  |          |           |              |      |          |            |            |        | JENDCA   | ENDCA     | STR        | JSTR     | JENDC | ENDC         | AWDG |    |   |   |   |   |   |   |   |   |   |   |   |   |   |
|        | Reset Value  | 0           |            |    |             |          |            |             |    |          |             |           |          |             |           |              |                  |          |           |              |      |          |            |            |        | 0        | 0         | 0          | 0        | 0     | 0            |      |    |   |   |   |   |   |   |   |   |   |   |   |   |   |
| 004h   | ADC_CTRL1    | Reserved    |            |    |             |          |            |             |    |          |             | AWDGERCH  | AWDGEICH | Reserved    |           |              |                  |          |           | DCTU[2:0]    | DJCH | DREGCH   | AUTOJC     | AWDGSLEN   | SCANMD | JENDCIEN | AWDGIEN   | ENCIDIEN   | Reserved |       | AWDGGCH[3:0] |      |    |   |   |   |   |   |   |   |   |   |   |   |   |   |
|        | Reset Value  | 0           |            |    |             |          |            |             |    |          |             | 0         | 0        | 0           |           |              |                  |          |           | 0            | 0    | 0        | 0          | 0          | 0      | 0        | 0         | 0          | 0        | 0     | 0            | 0    | 0  | 0 | 0 | 0 | 0 |   |   |   |   |   |   |   |   |   |
| 008h   | ADC_CTRL2    | Reserved    |            |    |             |          |            |             |    |          |             | TEMPEN    | SWSTRRCH | SWSTRJCH    | EXTRTRIG  | EXTRSEL[2:0] |                  | Reserved | EXTJTRIG  | EXTISEL[2:0] |      | ALIG     | Reserved   |            |        | ENDMA    | Reserved  |            |          |       |              | CTU  | ON |   |   |   |   |   |   |   |   |   |   |   |   |   |
|        | Reset Value  | 0           |            |    |             |          |            |             |    |          |             | 0         | 0        | 0           | 0         | 0            | 0                | 0        | 0         | 0            | 0    | 0        | 0          | 0          | 0      | 0        | 0         | 0          | 0        | 0     | 0            | 0    | 0  | 0 | 0 | 0 | 0 | 0 |   |   |   |   |   |   |   |   |
| 00Ch   | ADC_SAMPT1   | Reserved    |            |    |             |          |            |             |    |          |             |           |          |             |           |              |                  |          |           |              |      |          |            |            |        |          |           |            |          |       |              |      |    |   |   |   |   |   |   |   |   |   |   |   |   |   |
|        | Reset Value  | 0           |            |    |             |          |            |             |    |          |             |           |          |             |           |              |                  |          |           |              |      |          |            |            |        |          |           |            |          |       |              |      |    |   |   |   |   |   |   |   |   |   |   |   |   |   |
| 010h   | ADC_SAMPT2   | SAMP15[3:0] |            |    | SAMP14[3:0] |          |            | SAMP13[3:0] |    |          | SAMP12[3:0] |           |          | SAMP11[3:0] |           |              | SAMP10[3:0]      |          |           | SAMP9[3:0]   |      |          | SAMP8[3:0] |            |        |          |           |            |          |       |              |      |    |   |   |   |   |   |   |   |   |   |   |   |   |   |
|        | Reset Value  | 0           | 0          | 0  | 0           | 0        | 0          | 0           | 0  | 0        | 0           | 0         | 0        | 0           | 0         | 0            | 0                | 0        | 0         | 0            | 0    | 0        | 0          | 0          | 0      | 0        | 0         | 0          | 0        | 0     | 0            | 0    | 0  |   |   |   |   |   |   |   |   |   |   |   |   |   |
| 014h   | ADC_SAMPT3   | SAMP7[3:0]  |            |    | SAMP6[3:0]  |          |            | SAMP5[3:0]  |    |          | SAMP4[3:0]  |           |          | SAMP3[3:0]  |           |              | SAMP2[3:0]       |          |           | SAMP1[3:0]   |      |          |            |            |        |          |           |            |          |       |              |      |    |   |   |   |   |   |   |   |   |   |   |   |   |   |
|        | Reset Value  | 0           | 0          | 0  | 0           | 0        | 0          | 0           | 0  | 0        | 0           | 0         | 0        | 0           | 0         | 0            | 0                | 0        | 0         | 0            | 0    | 0        | 0          | 0          | 0      | 0        | 0         | 0          | 0        | 0     | 0            | 0    | 0  |   |   |   |   |   |   |   |   |   |   |   |   |   |
| 018h   | ADC_JOFFSET1 | Reserved    |            |    |             |          |            |             |    |          |             |           |          |             |           |              | OFFSETJCH1[11:0] |          |           |              |      |          |            |            |        |          |           |            |          |       |              |      |    |   |   |   |   |   |   |   |   |   |   |   |   |   |
|        | Reset Value  | 0           |            |    |             |          |            |             |    |          |             |           |          |             |           |              | 0                | 0        | 0         | 0            | 0    | 0        | 0          | 0          | 0      | 0        | 0         | 0          | 0        | 0     | 0            | 0    | 0  | 0 | 0 | 0 | 0 | 0 | 0 | 0 | 0 | 0 | 0 | 0 | 0 |   |
| 01Ch   | ADC_JOFFSET2 | Reserved    |            |    |             |          |            |             |    |          |             |           |          |             |           |              | OFFSETJCH2[11:0] |          |           |              |      |          |            |            |        |          |           |            |          |       |              |      |    |   |   |   |   |   |   |   |   |   |   |   |   |   |
|        | Reset Value  | 0           |            |    |             |          |            |             |    |          |             |           |          |             |           |              | 0                | 0        | 0         | 0            | 0    | 0        | 0          | 0          | 0      | 0        | 0         | 0          | 0        | 0     | 0            | 0    | 0  | 0 | 0 | 0 | 0 | 0 | 0 | 0 | 0 | 0 | 0 | 0 | 0 |   |
| 020h   | ADC_JOFFSET3 | Reserved    |            |    |             |          |            |             |    |          |             |           |          |             |           |              | OFFSETJCH3[11:0] |          |           |              |      |          |            |            |        |          |           |            |          |       |              |      |    |   |   |   |   |   |   |   |   |   |   |   |   |   |
|        | Reset Value  | 0           |            |    |             |          |            |             |    |          |             |           |          |             |           |              | 0                | 0        | 0         | 0            | 0    | 0        | 0          | 0          | 0      | 0        | 0         | 0          | 0        | 0     | 0            | 0    | 0  | 0 | 0 | 0 | 0 | 0 | 0 | 0 | 0 | 0 | 0 | 0 | 0 | 0 |
| 024h   | ADC_JOFFSET4 | Reserved    |            |    |             |          |            |             |    |          |             |           |          |             |           |              | OFFSETJCH4[11:0] |          |           |              |      |          |            |            |        |          |           |            |          |       |              |      |    |   |   |   |   |   |   |   |   |   |   |   |   |   |
|        | Reset Value  | 0           |            |    |             |          |            |             |    |          |             |           |          |             |           |              | 0                | 0        | 0         | 0            | 0    | 0        | 0          | 0          | 0      | 0        | 0         | 0          | 0        | 0     | 0            | 0    | 0  | 0 | 0 | 0 | 0 | 0 | 0 | 0 | 0 | 0 | 0 | 0 | 0 | 0 |
| 028h   | ADC_WDGHIGH  | Reserved    |            |    |             |          |            |             |    |          |             |           |          |             |           |              | HTH[11:0]        |          |           |              |      |          |            |            |        |          |           |            |          |       |              |      |    |   |   |   |   |   |   |   |   |   |   |   |   |   |
|        | Reset Value  | 0           |            |    |             |          |            |             |    |          |             |           |          |             |           |              | 0                | 0        | 0         | 0            | 0    | 0        | 0          | 0          | 0      | 0        | 0         | 0          | 0        | 0     | 0            | 0    | 0  | 0 | 0 | 0 | 0 | 0 | 0 | 0 | 0 | 0 | 0 | 0 | 0 | 0 |
| 02Ch   | ADC_WDGLow   | Reserved    |            |    |             |          |            |             |    |          |             |           |          |             |           |              | LTH[11:0]        |          |           |              |      |          |            |            |        |          |           |            |          |       |              |      |    |   |   |   |   |   |   |   |   |   |   |   |   |   |
|        | Reset Value  | 0           |            |    |             |          |            |             |    |          |             |           |          |             |           |              | 0                | 0        | 0         | 0            | 0    | 0        | 0          | 0          | 0      | 0        | 0         | 0          | 0        | 0     | 0            | 0    | 0  | 0 | 0 | 0 | 0 | 0 | 0 | 0 | 0 | 0 | 0 | 0 | 0 | 0 |
| 030h   | ADC_RSEQ1    | Reserved    |            |    |             |          |            |             |    |          |             | LEN[3:0]  |          |             | Reserved  | SEQ16[3:0]   |                  |          | Reserved  | SEQ15[3:0]   |      |          | Reserved   | SEQ14[3:0] |        |          | Reserved  | SEQ13[3:0] |          |       |              |      |    |   |   |   |   |   |   |   |   |   |   |   |   |   |
|        | Reset Value  | 0           |            |    |             |          |            |             |    |          |             | 0         | 0        | 0           | 0         | 0            | 0                | 0        | 0         | 0            | 0    | 0        | 0          | 0          | 0      | 0        | 0         | 0          | 0        | 0     | 0            | 0    | 0  | 0 | 0 |   |   |   |   |   |   |   |   |   |   |   |
| 034h   | ADC_RSEQ2    | Reserved    | SEQ12[3:0] |    |             | Reserved | SEQ11[3:0] |             |    | Reserved | SEQ10[3:0]  |           |          | Reserved    | SEQ9[3:0] |              |                  | Reserved | SEQ8[3:0] |              |      | Reserved | SEQ7[3:0]  |            |        |          |           |            |          |       |              |      |    |   |   |   |   |   |   |   |   |   |   |   |   |   |
|        | Reset Value  | 0           | 0          | 0  | 0           | 0        | 0          | 0           | 0  | 0        | 0           | 0         | 0        | 0           | 0         | 0            | 0                | 0        | 0         | 0            | 0    | 0        | 0          | 0          | 0      | 0        | 0         | 0          | 0        | 0     | 0            | 0    | 0  |   |   |   |   |   |   |   |   |   |   |   |   |   |
| 038h   | ADC_RSEQ3    | Reserved    | SEQ6[3:0]  |    |             | Reserved | SEQ5[3:0]  |             |    | Reserved | SEQ4[3:0]   |           |          | Reserved    | SEQ3[3:0] |              |                  | Reserved | SEQ2[3:0] |              |      | Reserved | SEQ1[3:0]  |            |        |          |           |            |          |       |              |      |    |   |   |   |   |   |   |   |   |   |   |   |   |   |
|        | Reset Value  | 0           | 0          | 0  | 0           | 0        | 0          | 0           | 0  | 0        | 0           | 0         | 0        | 0           | 0         | 0            | 0                | 0        | 0         | 0            | 0    | 0        | 0          | 0          | 0      | 0        | 0         | 0          | 0        | 0     | 0            | 0    | 0  |   |   |   |   |   |   |   |   |   |   |   |   |   |
| 03Ch   | ADC_JSEQ     | Reserved    |            |    |             |          |            |             |    |          |             | JLEN[1:0] |          | Reserved    | JEQ4[3:0] |              |                  | Reserved | JEQ3[3:0] |              |      | Reserved | JEQ2[3:0]  |            |        | Reserved | JEQ1[3:0] |            |          |       |              |      |    |   |   |   |   |   |   |   |   |   |   |   |   |   |
|        | Reset Value  | 0           |            |    |             |          |            |             |    |          |             | 0         | 0        | 0           | 0         | 0            | 0                | 0        | 0         | 0            | 0    | 0        | 0          | 0          | 0      | 0        | 0         | 0          | 0        |       |              |      |    |   |   |   |   |   |   |   |   |   |   |   |   |   |
| 040h   | ADC_JDAT1    | Reserved    |            |    |             |          |            |             |    |          |             |           |          |             |           |              | JDAT1[15:0]      |          |           |              |      |          |            |            |        |          |           |            |          |       |              |      |    |   |   |   |   |   |   |   |   |   |   |   |   |   |
|        | Reset Value  | 0           |            |    |             |          |            |             |    |          |             |           |          |             |           |              | 0                | 0        | 0         | 0            | 0    | 0        | 0          | 0          | 0      | 0        | 0         | 0          | 0        | 0     | 0            | 0    | 0  | 0 | 0 | 0 | 0 | 0 | 0 | 0 | 0 | 0 | 0 | 0 | 0 | 0 |
| 044h   | ADC_JDAT2    | Reserved    |            |    |             |          |            |             |    |          |             |           |          |             |           |              | JDAT2[15:0]      |          |           |              |      |          |            |            |        |          |           |            |          |       |              |      |    |   |   |   |   |   |   |   |   |   |   |   |   |   |

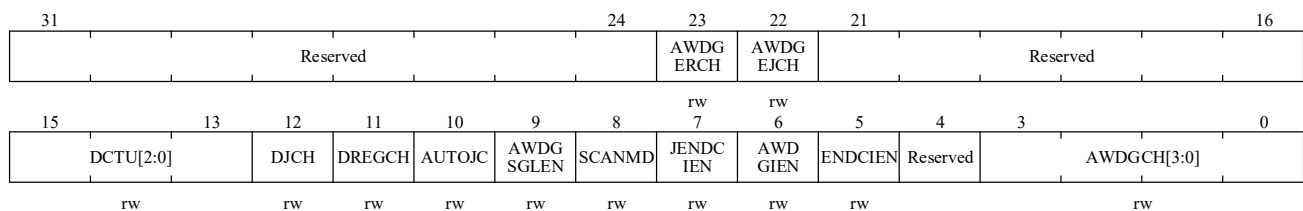


| Bit Field | Name  | Description  |
|-----------|-------|--|
| 3         | JSTR  | Injected channel start flag<br>This bit is set by hardware at the start of the injection channel conversion and cleared by software.<br>0: Injection sequence channel conversion has not started.<br>1: Injection sequence channel conversion has started. |
| 2         | JENDC | Injected channel end of conversion<br>This bit is set by hardware at the end of all injection sequence channel conversions and cleared by software<br>0: Conversion is not complete.<br>1: Conversion is complete.   |
| 1         | ENDC  | Conversion sequence channel end of conversion<br>This bit is set by hardware at the end of all regular( or injection) sequence channel conversion and cleared by software<br>0: Conversion is not complete.<br>1: Conversion is complete.                  |
| 0         | AWDG  | Analog watchdog flag<br>This bit is set by hardware and cleared by software when converted voltage values are outside the range defined by the ADC_LTR and ADC_HTR registers<br>0: Analog watchdog event not occurs;<br>1: Analog watchdog event occurs.   |

### 15.11.3 ADC Control Register 1 (ADC\_CTRL1)

Address offset: 0x04

Reset value: 0x0000 0000



| Bit Field | Name     | Description  |
|-----------|----------|--|
| 31:24     | Reserved | Reserved, the reset value must be maintained   |
| 23        | AWDGERCH | Analog watchdog enable on regular channels<br>This bit is set and cleared by the software.<br>0: Disables analog watchdog on regular channel.<br>1: Use analog watchdog on regular channels.         |
| 22        | AWDGEJCH | Analog watchdog enable on injected channels<br>This bit is set and cleared by the software.<br>0: Disables analog watchdog on injection channel.<br>1: Use analog watchdog on the injection channel. |



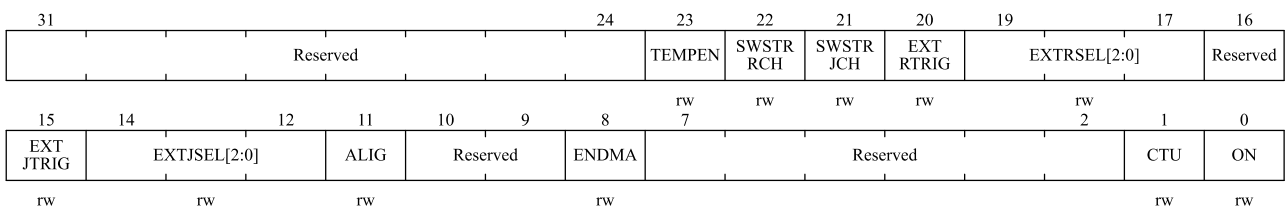
| Bit Field | Name      | Description  |
|-----------|-----------|--|
| 21:16     | Reserved  | Reserved, the reset value must be maintained   |
| 15:13     | DCTU[2:0] | Discontinuous mode channel count<br>The software uses these bits to define the number of channels for converting regulars after receiving an external trigger in intermittent mode<br>000: 1 channel<br>001: 2 channels<br>...<br>111: 8 channels  |
| 12        | DJCH      | Discontinuous mode on injected channels<br>This bit is set and cleared by the software. It is used to turn on or off discontinuous mode on injected channels.<br>0: Disable discontinuous mode on injection sequence channel<br>1: Enable discontinuous mode on injection sequence channel   |
| 11        | DREGCH    | Discontinuous mode is on regular channels.<br>This bit is set and cleared by the software. It is used to turn on or off discontinuous mode on regular channels.<br>0: Disable discontinuous mode on regular sequence channel<br>1: Enable discontinuous mode on regular sequence channel   |
| 10        | AUTOJC    | Automatic injected sequence conversion<br>This bit is set and cleared by the software to enable or disable automatic injection sequence channel conversion after regular sequence channel conversion is complete<br>0: Disable automatic injection channel conversion.<br>1: Enable automatic injection channel conversion.  |
| 9         | AWDGSLEN  | Enable the watchdog on a single channel in scan mode<br>This bit is set and cleared by software to enable or disable analog watchdog functions on channels specified by ADC_CTRL1.AWDGCH[3:0]<br>0: Use watchdog on all channels.<br>1: Use watchdog on single channel.  |
| 8         | SCANMD    | Scan mode<br>This bit is set and cleared by the software to enable or disable scan mode. In scan mode, the conversion is made by ADC_RSEQx or the selected channel of the ADC_JSEQ register.<br>0: Disable scan mode.<br>1: Enable scan mode.<br><i>Note: If the ADC_CTRL1.ENDCIEN or ADC_CTRL1.JENDCIEN bits are set separately, ADC_STS.ENDC or ADC_STS.JENDC interrupts occur only after the last channel has been converted.</i> |
| 7         | JENDCIEN  | Interrupt enable for injected channels<br>This bit is set and cleared by the software to disallow or allow interrupts after all injection channel conversions have finished.<br>0: Disable JENDC interruption.<br>1: Enable JENDC interruption. An interrupt occurred when hardware set ADC_STS.JENDC  |

| Bit Field | Name        | Description   |
|-----------|-------------|---|
|           |             | bit.  |
| 6         | AWDGIEN     | Analog watchdog interrupt enable<br>This bit is set and cleared by software to disallow or allow interrupt generated by analog watchdog. In scan mode, if the watchdog detects an out-of-range value, the scan is aborted only when that bit is set.<br>0: Disable analog watchdog interruption.<br>1: Enable analog watchdog interruption. |
| 5         | ENDCIEN     | Interrupt enable for any channels<br>This bit is set and cleared by the software to disallow or allow interrupts to occur after the regular channel conversion ends.<br>0: Disable ENDC interruption.<br>1: Enable ENDC interruption.   |
| 4         | Reserved    | Reserved,the reset value must be maintained   |
| 3:0       | AWDGCH[3:0] | Analog watchdog channel select bits<br>These bits are set and cleared by software to select input channels that analog watchdog protection.<br>0000: ADC analog input channel 0<br>0001: ADC analog input channel 1<br>...<br>1110: ADC analog input channel 14<br>1111: ADC analog input channel 15<br>Reserved all other values.          |

**15.11.4 ADC Control Register 2 (ADC\_CTRL2)**

Address offset: 0x08

Reset value: 0x0000 0000



| Bit Field | Name     | Description   |
|-----------|----------|---|
| 31:24     | Reserved | Reserved,the reset value must be maintained   |
| 23        | TEMPEN   | Temperature sensor Enable<br>This bit is set and cleared by the software to enable or disable the temperature sensor and V <sub>REFINT</sub> Channel. |

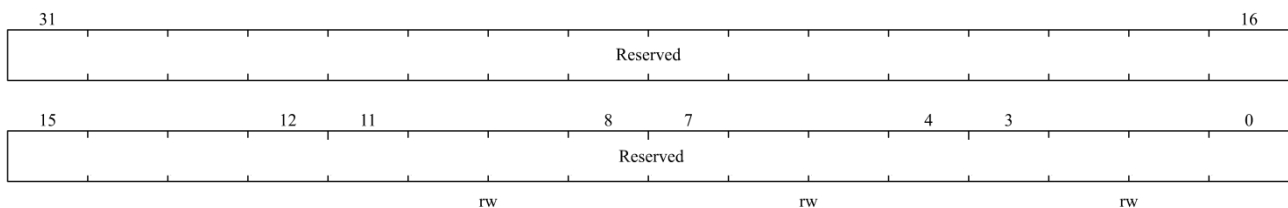
| Bit Field | Name         | Description  |
|-----------|--------------|--|
|           |              | 0: Disables the temperature sensor.<br>1: Enable the temperature sensor.   |
| 22        | SWSTRRCH     | Start conversion of regular channels<br>This bit is set by the software to start the conversion and cleared by the hardware as soon as the conversion begins. If SWSTRRCH is selected as the trigger event in the ADC_CTRL2.EXTRSEL[2:0] bit, which is used to initiate the conversion of a set of regular channels<br>0: Reset state.<br>1: Starts converting the regular channel.  |
| 21        | SWSTRJCH     | Start conversion of injected channels<br>This bit is set by the software to initiate the conversion and can be cleared by the software or by the hardware as soon as the conversion begins. If SWSTRJCH is selected as the trigger event in the ADC_CTRL2.EXTJSEL[2:0] bit, which is used to initiate a conversion of a set of injected channels<br>0: Reset state.<br>1: Starts converting the injection channel.   |
| 20        | EXTRTRIG     | External trigger conversion mode for regular channels<br>This bit is set and cleared by software to enable or disable external triggering events that can start regular sequence conversion.<br>0: Start conversion without external events.<br>1: Use an external event to start the conversion.  |
| 19:17     | EXTRSEL[2:0] | External event select for regular sequence<br>These bits select external events to start the regular sequence conversion<br>The triggering configuration of ADC is as follows<br>000: indicates the CC1 event of timer 1      100: indicates the TRGO event of timer 3<br>001: indicates the CC2 event of timer 1      101: Reserved<br>010: indicates the CC3 event of timer 1      110: EXTI line 0~15/TIM8_TRGO event<br>011: Reserved      111: SWSTRRCH |
| 16        | Reserved     | Reserved,the reset value must be maintained  |
| 15        | EXTJTRIG     | External trigger conversion mode for injected channels<br>This bit is set and cleared by software to enable or disable external triggering events that can start injection sequence conversion.<br>0: Start conversion without external events.<br>1: Use an external event to start the conversion.   |
| 14:12     | EXTJSEL[2:0] | External event select for injected sequence<br>These bits select the External event used to trigger the injected sequence conversion.<br>The triggering configuration of ADC is as follows<br>000: indicates the TRGO event of timer 1      100: indicates the CC4 event of timer 3<br>001: indicates the CC4 event of timer 1      101: Reserved<br>010: Reserved      110: EXTI line 0~15/TIM8_CC4 event   |

| Bit Field | Name     | Description  |
|-----------|----------|--|
|           |          | 011: Reserved<br>111: SWSTRJCH   |
| 11        | ALIG     | Data alignment<br>This bit is set and cleared by the software. Refer to Table 15-3 and Table 15-4.<br>0: Right-aligned.<br>1: Left-aligned.  |
| 10:9      | Reserved | Reserved,the reset value must be maintained  |
| 8         | ENDMA    | Direct memory access mode<br>This bit is set and cleared by the software. See the DMA Controller chapter for details.<br>0: Do not use DMA mode.<br>1: Use DMA mode.   |
| 7:2       | Reserved | Reserved,the reset value must be maintained  |
| 1         | CTU      | Continuous conversion<br>This bit is set and cleared by the software. If this bit is set, the conversion continues until the bit is cleared.<br>0: Single conversion mode.<br>1: Continuous conversion mode.   |
| 0         | ON       | A/D converter ON/OFF<br>This bit is set and cleared by the software. When the bit is '0 ', writing '1' will wake the ADC from power-off mode.<br>When the bit is '1 ', writing '1' starts the conversion. The application should note that there is a delay $t_{STAB}$ between the time the converter is powered on and the time the conversion begins, see Figure 15-3.<br>0: Close ADC conversion/calibration and enter PD mode.<br>1: Start ADC and start conversion.<br><i>Note: If there are other bits changed in this register along with ON, the conversion will not be triggered. This is to prevent the wrong conversion from being triggered.</i> |

### 15.11.5 ADC Sampling Time Register 1 (ADC\_SAMPT1)

Address offset: 0x0C

Reset value: 0x0000 0000

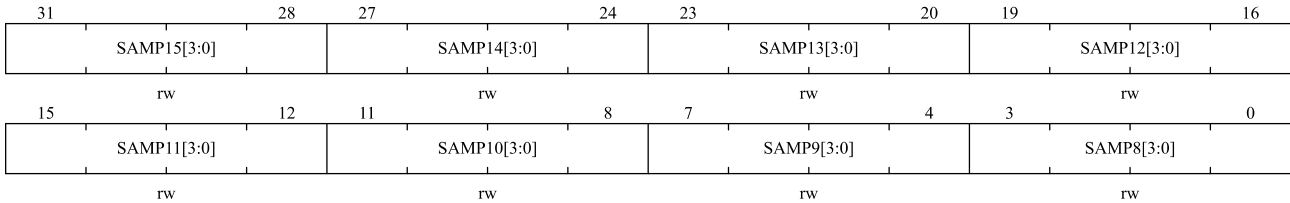


| Bit field | Name     | Description                                 |
|-----------|----------|---|
| 31:0      | Reserved | Reserved,the reset value must be maintained |

### 15.11.6 ADC Sampling Time Register 2 (ADC\_SAMPT2)

Address offset: 0x10

Reset value: 0x0000 0000

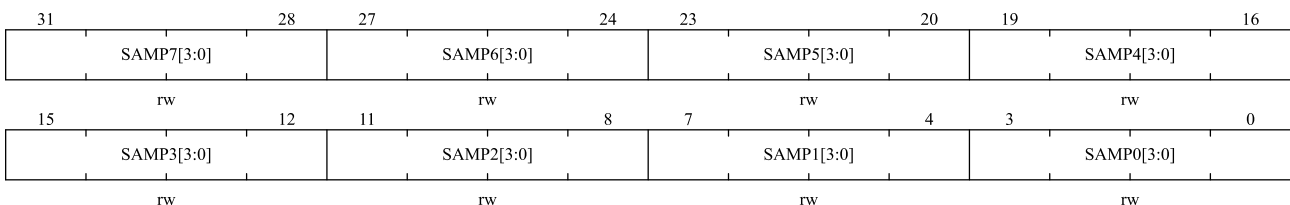


| Bit Field       | Name                 | Description   |                |                 |                |                  |                 |                  |                 |                  |                 |                  |                 |                  |                 |                  |                 |                  |
|-----------------|----------------------|---|----------------|-----------------|----------------|------------------|-----------------|------------------|-----------------|------------------|-----------------|------------------|-----------------|------------------|-----------------|------------------|-----------------|------------------|
| 31:0            | SAMPx[3:0]<br>x=8~15 | <p>Channel x sample time selection</p> <p>These bits are used to independently select the sampling time for each channel. The channel selection bit must remain constant during the sampling period.</p> <table border="0"> <tr> <td>0000: 6 cycles</td> <td>1000: 88 cycles</td> </tr> <tr> <td>0001: 8 cycles</td> <td>1001: 120 cycles</td> </tr> <tr> <td>0010: 14 cycles</td> <td>1010: 182 cycles</td> </tr> <tr> <td>0011: 20 cycles</td> <td>1011: 240 cycles</td> </tr> <tr> <td>0100: 29 cycles</td> <td>1100: 300 cycles</td> </tr> <tr> <td>0101: 42 cycles</td> <td>1101: 400 cycles</td> </tr> <tr> <td>0110: 56 cycles</td> <td>1110: 480 cycles</td> </tr> <tr> <td>0111: 72 cycles</td> <td>1111: 600 cycles</td> </tr> </table> <p><i>Note: ADC analog channel 13 and channel 14 are internally connected to the temperature sensor and V<sub>REFINT</sub>, respectively.</i></p> | 0000: 6 cycles | 1000: 88 cycles | 0001: 8 cycles | 1001: 120 cycles | 0010: 14 cycles | 1010: 182 cycles | 0011: 20 cycles | 1011: 240 cycles | 0100: 29 cycles | 1100: 300 cycles | 0101: 42 cycles | 1101: 400 cycles | 0110: 56 cycles | 1110: 480 cycles | 0111: 72 cycles | 1111: 600 cycles |
| 0000: 6 cycles  | 1000: 88 cycles      |   |                |                 |                |                  |                 |                  |                 |                  |                 |                  |                 |                  |                 |                  |                 |                  |
| 0001: 8 cycles  | 1001: 120 cycles     |   |                |                 |                |                  |                 |                  |                 |                  |                 |                  |                 |                  |                 |                  |                 |                  |
| 0010: 14 cycles | 1010: 182 cycles     |   |                |                 |                |                  |                 |                  |                 |                  |                 |                  |                 |                  |                 |                  |                 |                  |
| 0011: 20 cycles | 1011: 240 cycles     |   |                |                 |                |                  |                 |                  |                 |                  |                 |                  |                 |                  |                 |                  |                 |                  |
| 0100: 29 cycles | 1100: 300 cycles     |   |                |                 |                |                  |                 |                  |                 |                  |                 |                  |                 |                  |                 |                  |                 |                  |
| 0101: 42 cycles | 1101: 400 cycles     |   |                |                 |                |                  |                 |                  |                 |                  |                 |                  |                 |                  |                 |                  |                 |                  |
| 0110: 56 cycles | 1110: 480 cycles     |   |                |                 |                |                  |                 |                  |                 |                  |                 |                  |                 |                  |                 |                  |                 |                  |
| 0111: 72 cycles | 1111: 600 cycles     |   |                |                 |                |                  |                 |                  |                 |                  |                 |                  |                 |                  |                 |                  |                 |                  |

### 15.11.7 ADC Sampling Time Register 3 (ADC\_SAMPT3)

Address offset: 0x14

Reset value: 0x0000 0000

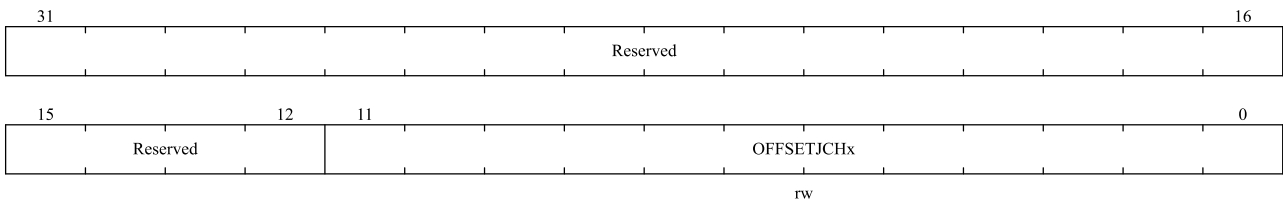


| Bit Field       | Name                | Description  |                |                 |                |                  |                 |                  |                 |                  |                 |                  |                 |                  |                 |                  |                 |                  |
|-----------------|---------------------|--|----------------|-----------------|----------------|------------------|-----------------|------------------|-----------------|------------------|-----------------|------------------|-----------------|------------------|-----------------|------------------|-----------------|------------------|
| 31: 0           | SAMPx[3:0]<br>x=0~7 | <p>Channel x sample time selection</p> <p>These bits are used to independently select the sampling time for each channel. The channel selection bit must remain constant during the sampling period.</p> <table> <tr> <td>0000: 6 cycles</td> <td>1000: 88 cycles</td> </tr> <tr> <td>0001: 8 cycles</td> <td>1001: 120 cycles</td> </tr> <tr> <td>0010: 14 cycles</td> <td>1010: 182 cycles</td> </tr> <tr> <td>0011: 20 cycles</td> <td>1011: 240 cycles</td> </tr> <tr> <td>0100: 29 cycles</td> <td>1100: 300 cycles</td> </tr> <tr> <td>0101: 42 cycles</td> <td>1101: 400 cycles</td> </tr> <tr> <td>0110: 56 cycles</td> <td>1110: 480 cycles</td> </tr> <tr> <td>0111: 72 cycles</td> <td>1111: 600 cycles</td> </tr> </table> | 0000: 6 cycles | 1000: 88 cycles | 0001: 8 cycles | 1001: 120 cycles | 0010: 14 cycles | 1010: 182 cycles | 0011: 20 cycles | 1011: 240 cycles | 0100: 29 cycles | 1100: 300 cycles | 0101: 42 cycles | 1101: 400 cycles | 0110: 56 cycles | 1110: 480 cycles | 0111: 72 cycles | 1111: 600 cycles |
| 0000: 6 cycles  | 1000: 88 cycles     |  |                |                 |                |                  |                 |                  |                 |                  |                 |                  |                 |                  |                 |                  |                 |                  |
| 0001: 8 cycles  | 1001: 120 cycles    |  |                |                 |                |                  |                 |                  |                 |                  |                 |                  |                 |                  |                 |                  |                 |                  |
| 0010: 14 cycles | 1010: 182 cycles    |  |                |                 |                |                  |                 |                  |                 |                  |                 |                  |                 |                  |                 |                  |                 |                  |
| 0011: 20 cycles | 1011: 240 cycles    |  |                |                 |                |                  |                 |                  |                 |                  |                 |                  |                 |                  |                 |                  |                 |                  |
| 0100: 29 cycles | 1100: 300 cycles    |  |                |                 |                |                  |                 |                  |                 |                  |                 |                  |                 |                  |                 |                  |                 |                  |
| 0101: 42 cycles | 1101: 400 cycles    |  |                |                 |                |                  |                 |                  |                 |                  |                 |                  |                 |                  |                 |                  |                 |                  |
| 0110: 56 cycles | 1110: 480 cycles    |  |                |                 |                |                  |                 |                  |                 |                  |                 |                  |                 |                  |                 |                  |                 |                  |
| 0111: 72 cycles | 1111: 600 cycles    |  |                |                 |                |                  |                 |                  |                 |                  |                 |                  |                 |                  |                 |                  |                 |                  |

### 15.11.8 ADC Injected Channel Data Offset Register X (ADC\_JOFFSETx) (X=1...4)

Address offset: 0x18-0x24

Reset value: 0x0000 0000

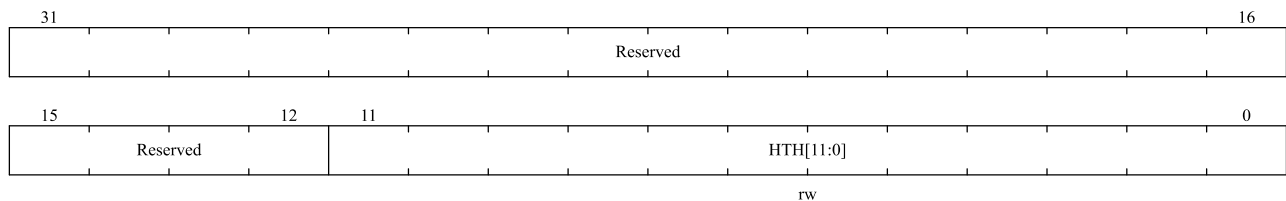


| Bit Field | Name             | Description  |
|-----------|------------------|--|
| 31:12     | Reserved         | Reserved,the reset value must be maintained  |
| 11:0      | OFFSETJCHx[11:0] | <p>Data offset for injected channel x</p> <p>These bits define the values used to subtract from the original conversion data when the conversion is injected into the channel. The result of the conversion can be read in the ADC_JDATx register.</p> |

### 15.11.9 ADC Watchdog High Threshold Register (ADC\_WDGHIGH)

Address offset: 0x28

Reset value: 0x0000 0FFF

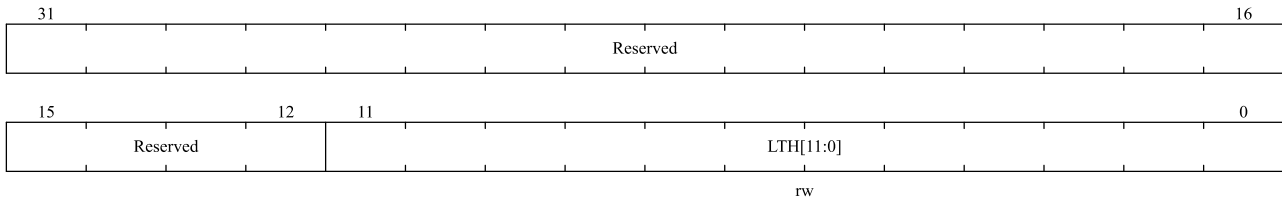


| Bit Field | Name      | Description  |
|-----------|-----------|--|
| 31:12     | Reserved  | Reserved,the reset value must be maintained  |
| 11:0      | HTH[11:0] | Analog watchdog high threshold<br>These bits define the high thresholds for analog watchdog. |

### 15.11.10 ADC Watchdog Low Threshold Register (ADC\_WDGLow)

Address offset: 0x2C

Reset value: 0x0000 0000

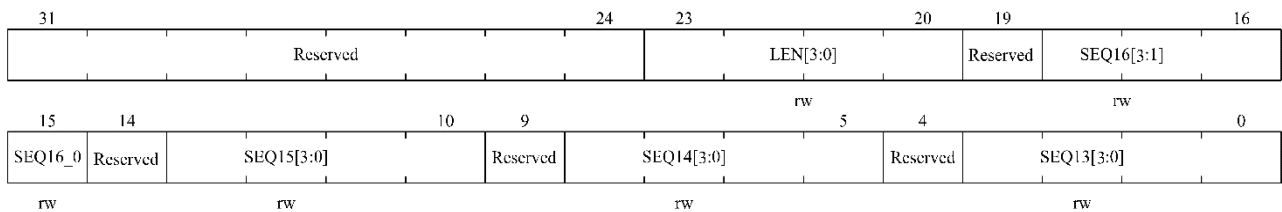


| Bit Field | Name      | Description  |
|-----------|-----------|--|
| 31:12     | Reserved  | Reserved,the reset value must be maintained  |
| 11:0      | LTH[11:0] | Analog watchdog low threshold<br>These bits define the low thresholds for analog watchdog. |

### 15.11.11 ADC Regular Sequence Register 1 (ADC\_RSEQ1)

Address offset: 0x30

Reset value: 0x0000 0000



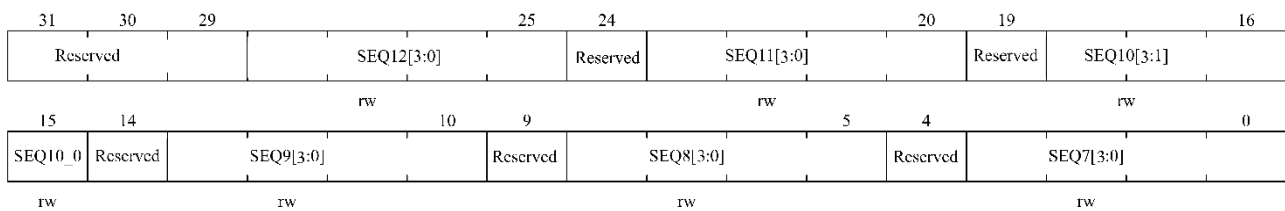
| Bit Field | Name       | Description  |
|-----------|------------|--|
| 31:24     | Reserved   | Reserved,the reset value must be maintained  |
| 23:20     | LEN[3:0]   | Regular channel sequence length<br>These bits are software-defined as the number of channels in the regular sequence channel conversion.<br>0000: 1 conversion<br>0001: 2 conversions<br>...<br>1111: 16 conversions |
| 19        | Reserved   | Reserved,the reset value must be maintained  |
| 18:15     | SEQ16[3:0] | 16th conversion in regular sequence<br>These bits are software-defined as the number (0 to 15) of the 16th conversion channel in the conversion sequence.  |

| Bit Field | Name       | Description                                 |
|-----------|------------|---|
| 14        | Reserved   | Reserved,the reset value must be maintained |
| 13:10     | SEQ15[3:0] | 15th conversion in regular sequence         |
| 9         | Reserved   | Reserved,the reset value must be maintained |
| 8:5       | SEQ14[3:0] | 14th conversion in regular sequence         |
| 4         | Reserved   | Reserved,the reset value must be maintained |
| 3:0       | SEQ13[3:0] | 13th conversion in regular sequence         |

### 15.11.12 ADC Regular Sequence Register 2 (ADC\_RSEQ2)

Address offset: 0x34

Reset value: 0x0000 0000



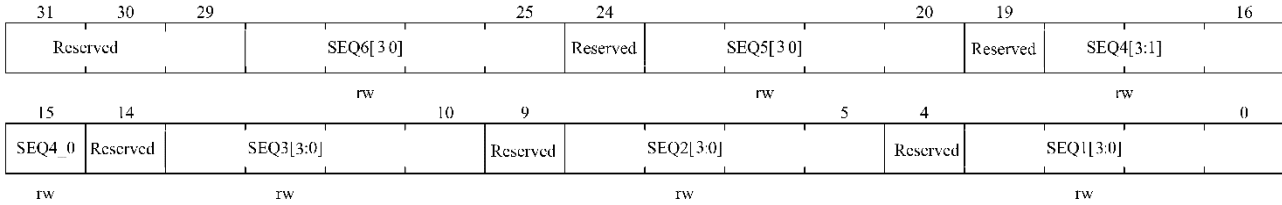
| Bit Field | Name       | Description   |
|-----------|------------|---|
| 31:29     | Reserved   | Reserved,the reset value must be maintained   |
| 28:25     | SEQ12[3:0] | 12th conversion in regular sequence<br>These bits are software-defined as the number (0 to 15) of the 12th conversion channel in the conversion sequence. |
| 24        | Reserved   | Reserved,the reset value must be maintained   |
| 23:20     | SEQ11[3:0] | 11th conversion in regular sequence   |
| 19        | Reserved   | Reserved,the reset value must be maintained   |
| 18:15     | SEQ10[3:0] | 10th conversion in regular sequence   |
| 14        | Reserved   | Reserved,the reset value must be maintained   |
| 13:10     | SEQ9[3:0]  | 9th conversion in regular sequence  |
| 9         | Reserved   | Reserved,the reset value must be maintained   |
| 8:5       | SEQ8[3:0]  | 8th conversion in regular sequence  |
| 4         | Reserved   | Reserved,the reset value must be maintained   |
| 3:0       | SEQ7[3:0]  | 7th conversion in regular sequence  |

### 15.11.13 ADC Regular Sequence Register 3 (ADC\_RSEQ3)

Address offset: 0x38

Reset value: 0x0000 0000



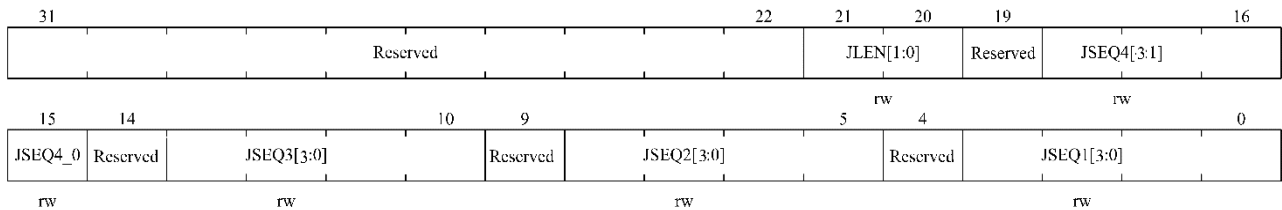


| Bit Field | Name      | Description   |
|-----------|-----------|---|
| 31:29     | Reserved  | Reserved,the reset value must be maintained   |
| 28:25     | SEQ6[3:0] | 6th conversion in regular sequence<br>These bits are software-defined as the number (0 to 15) of the 6th transition channel in the conversion sequence. |
| 24        | Reserved  | Reserved,the reset value must be maintained   |
| 23:20     | SEQ5[3:0] | 5th conversion in regular sequence  |
| 19        | Reserved  | Reserved,the reset value must be maintained   |
| 18:15     | SEQ4[3:0] | 4th conversion in regular sequence  |
| 14        | Reserved  | Reserved,the reset value must be maintained   |
| 13:10     | SEQ3[3:0] | 3rd conversion in regular sequence  |
| 9         | Reserved  | Reserved,the reset value must be maintained   |
| 8:5       | SEQ2[3:0] | 2nd conversion in regular sequence  |
| 4         | Reserved  | Reserved,the reset value must be maintained   |
| 3:0       | SEQ1[3:0] | 1st conversion in regular sequence  |

### 15.11.14 ADC Injection Sequence Register (ADC\_JSEQ)

Address offset: 0x3C

Reset value: 0x0000 0000



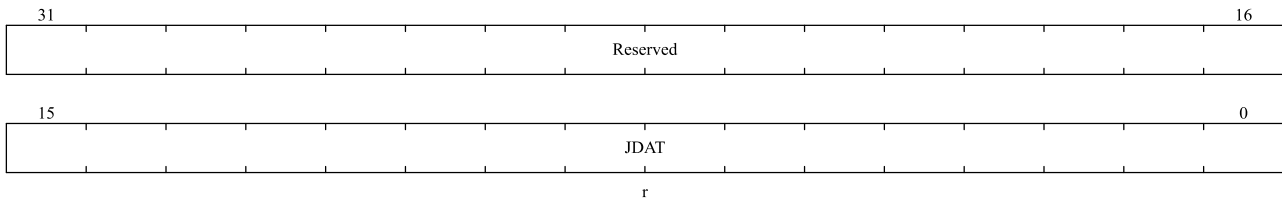
| Bit Field | Name      | Description   |
|-----------|-----------|---|
| 31:22     | Reserved  | Reserved,the reset value must be maintained   |
| 21:20     | JLEN[1:0] | Injected sequence length<br>These bits are software-defined as the number of channels in the injected channel conversion sequence.<br>00: 1 conversion<br>01: 2 conversions<br>10: 3 conversions<br>11: 4 conversions |

| Bit Field | Name       | Description  |
|-----------|------------|--|
| 19        | Reserved   | Reserved,the reset value must be maintained  |
| 18:15     | JSEQ4[3:0] | This is the 4th conversion in the injected sequence.<br>These bits are software-defined as the number (0 to 15) of the fourth transition channel in the conversion sequence.<br><i>Note: Different from regular conversion sequences, if the length of ADC_JSEQ.JLEN[1:0] is less than 4, the sequence of conversion starts from (4-JLEN). For example, ADC_JSEQ[21:0] = 10 00011 00011 00111 00010 means that the scan conversion will be converted in the following channel order: 7, 3, 3 instead of 2, 7, 3.</i> |
| 14        | Reserved   | Reserved,the reset value must be maintained  |
| 13:10     | JSEQ3[3:0] | 3rd conversion in injected sequence  |
| 9         | Reserved   | Reserved,the reset value must be maintained  |
| 8:5       | JSEQ2[3:0] | 2nd conversion in injected sequence  |
| 4         | Reserved   | Reserved,the reset value must be maintained  |
| 3:0       | JSEQ1[3:0] | 1st conversion in injected sequence  |

### 15.11.15 ADC Injection Data Register X (ADC\_JDATx) (x= 1...4)

Address offset: 0x40 - 0x4C

Reset value: 0x0000 0000

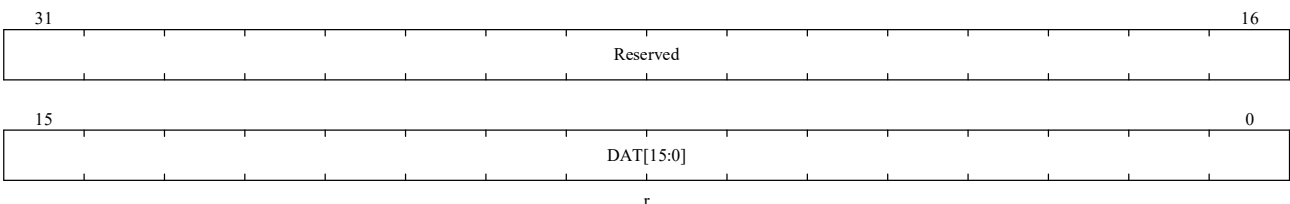


| Bit Field | Name        | Description   |
|-----------|-------------|---|
| 31:16     | Reserved    | Reserved,the reset value must be maintained   |
| 15:0      | JDATx[15:0] | Injected data for conversions<br>These bits are read-only and contain the conversion results of the injected channel. The data is left-aligned or right-aligned |

### 15.11.16 ADC Regulars Data Register (ADC\_DAT)

Address offset: 0x50

Reset value: 0x0000 0000

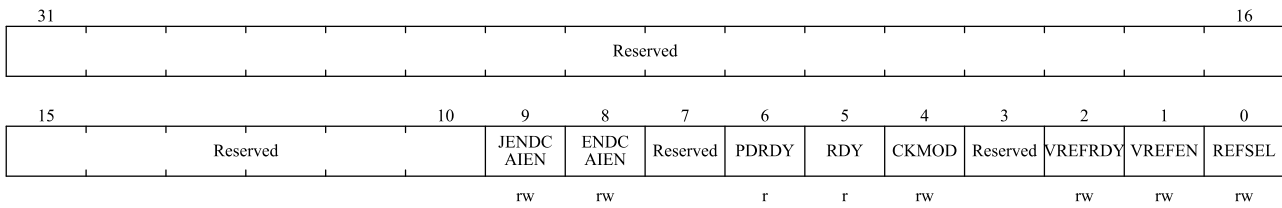


| Bit Field | Name      | Description   |
|-----------|-----------|---|
| 32:16     | Reserved  | Reserved,the reset value must be maintained   |
| 15:0      | DAT[15:0] | Regular data for conversion<br>These bits are read-only and contain the conversion results of the regular channel. The data is left-aligned or right-aligned. |

### 15.11.17 ADC Control Register 3 (ADC\_CTRL3)

Address offset: 0x54

Reset value: 0x0000 0040



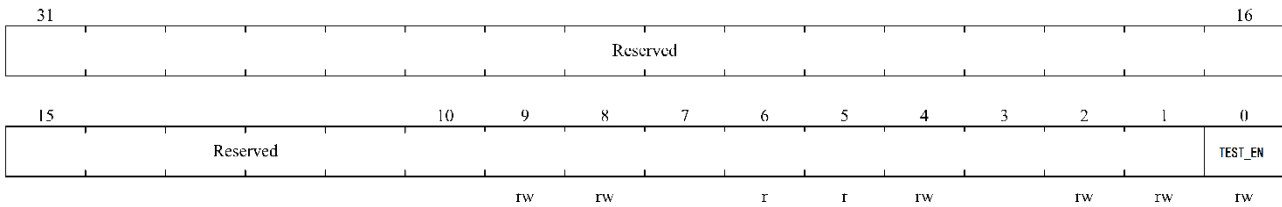
| Bit Field | Name      | Description   |
|-----------|-----------|---|
| 31:10     | Reserved  | Reserved,the reset value must be maintained   |
| 9         | JENDCAIEN | Interrupt enable for any injected channels<br>This bit is set and cleared by the software to enable/disable the injection channel conversion end interrupt<br>0: ADC_STS.JENDCA interrupt is disabled<br>1: ADC_STS.JENDCA interrupt is enabled |
| 8         | ENDCAIEN  | Interrupt enable for any channels<br>This bit is set and cleared by the software to enable/disable any channel conversion end the interrupt<br>0: ADC_STS.ENDCA interrupt is disabled<br>1: ADC_STS.ENDCA interrupt is enabled                  |
| 7         | Reserved  | Reserved, the value is forcibly set to 1.   |
| 6         | PDRDY     | ADC power ready<br>0: ADC is powered on<br>1: ADC is powered down   |
| 5         | RDY       | ADC ready<br>0: Not ready<br>1: Get ready   |
| 4         | CKMOD     | Clock mode<br>0: Select AHB for synchronization clock<br>1: Select PLL for asynchronous clock   |
| 3         | Reserved  | Reserved,the reset value must be maintained   |
| 2         | VREFRDY   | VREFINT_READY<br>ADC internal input buffer ready status, software must check this status bit before measuring VREFINT   |

| Bit Field | Name   | Description   |
|-----------|--------|---|
|           |        | 0: VREFINT not ready<br>1: VREFINT is ready   |
| 1         | VREFEN | VREFINT Enable<br>ADC internal input buffer is enabled, software must enable this bit before measuring VREFINT<br>0: Disable VREFINT measurement<br>1: Enable VREFINT measurement |
| 0         | REFSEL | ADC reference source selset<br>0: The reference source is the external reference V <sub>DD</sub><br>1: The reference source is the internal voltage 2.4V                          |

**15.11.18 ADC Test Register (ADC\_TEST)**

Address offset: 0x58

Reset value: 0x0000 0000

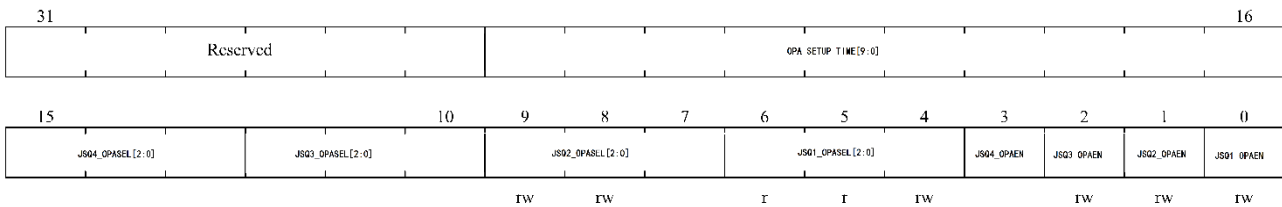


| Bit Field | Name     | Description   |
|-----------|----------|---|
| 31:1      | Reserved | Reserved,the reset value must be maintained   |
| 0         | TEST_EN  | ADC test mode enable<br>0: ADC operates in normal sampling mode<br>1: ADC operates in test mode |

**15.11.19 ADC OPA Control Register (ADC\_OPACTRL)**

Address offset: 0x5C

Reset value: 0x0000 0000



| Bit Field | Name                | Description                                     |
|-----------|---------------------|---|
| 31:26     | Reserved            | Reserved,the reset value must be maintained     |
| 25:16     | OPA_SETUP_TIME[9:0] | Setup time for OPA mux<br>0: 0 ADC clock cycles |

| Bit Field | Name              | Description   |
|-----------|-------------------|---|
|           |                   | 1: 1 ADC clock cycles<br>...<br>1023: 1023 ADC clock cycles   |
| 15:13     | JSQ4_OPASEL[2:0]  | Injected channel 4 for OPA mux selection  |
| 12:10     | JSQ3_OPASEL [2:0] | Injected channel 3 for OPA mux selection  |
| 9:7       | JSQ2_OPASEL [2:0] | Injected channel 2 for OPA mux selection  |
| 6:4       | JSQ1_OPASEL [2:0] | Injected channel 1 for OPA mux selection  |
| 3         | JSQ4_OPAEN        | Injected channel 4 for OPA mux enable<br>0: do not switch<br>1: Switch to the channel indicated by the JSQ4_OPASEL register |
| 2         | JSQ3_OPAEN        | Injected channel 3 for OPA mux enable<br>0: do not switch<br>1: Switch to the channel indicated by the JSQ3_OPASEL register |
| 1         | JSQ2_OPAEN        | Injected channel 2 for OPA mux enable<br>0: do not switch<br>1: Switch to the channel indicated by the JSQ2_OPASEL register |
| 0         | JSQ1_OPAEN        | Injected channel 1 for OPA mux enable<br>0: do not switch<br>1: Switch to the channel indicated by the JSQ1_OPASEL register |

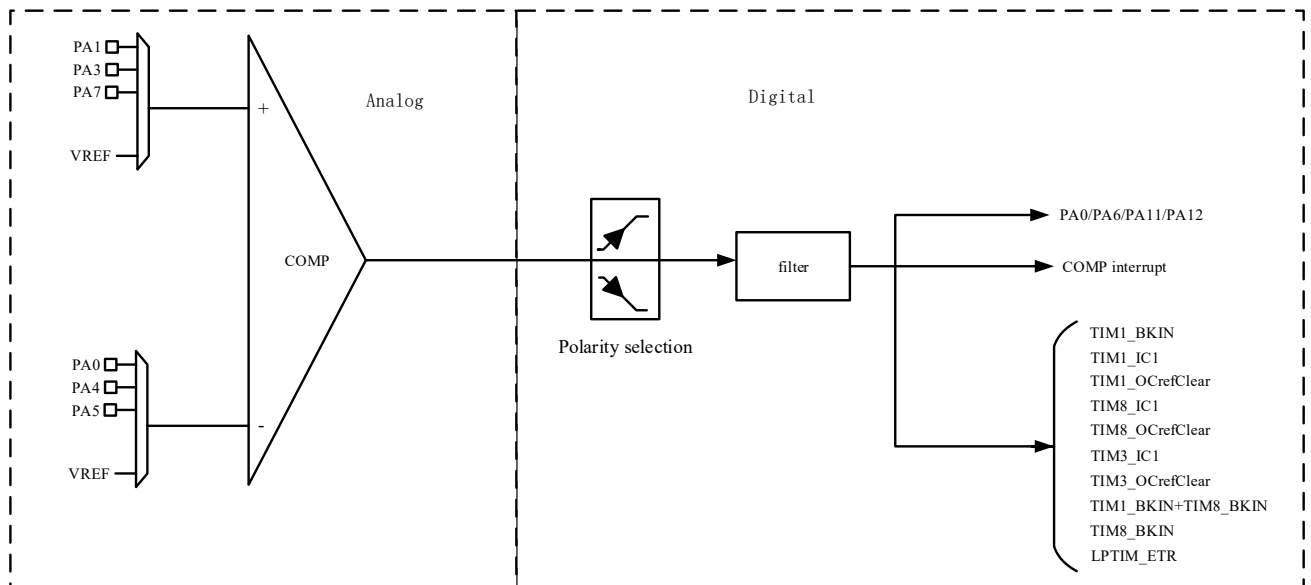
## 16 Comparator (COMP)

The COMP module is used to compare the magnitude of the two input analog voltages, and output high/low levels according to the comparison result. When the "INP" input voltage is higher than the "INM" input voltage, the comparator output is high, and when the "INP" input voltage is lower than the "INM" input voltage, the comparator output is low.

### 16.1 COMP System Connection Block Diagram

The COMP module supports an independent comparator, which is connected to the APB1 bus.

Figure 16-1 Comparator System Connection Diagram



### 16.2 COMP Features

- An independent comparator COMP, which is a low-power comparator (can operate in LPRUN, SLEEP and STOP modes)
- Embedded a 64-level programmable reference input comparison voltage source  $V_{REF}$
- Supports filter clock, filter reset
- Output polarity can be configured high and low
- Hysteresis configuration configurable none, low, medium, high
- Comparison results can be output to I/O ports or trigger timers for capture events, OCREF\_CLR events, brake events, and interrupt generation
- Input channel can select I/O port,  $V_{REF}$
- Can be equipped with read-only or read-write, in the case of locking, it needs to be reset to unlock
- Supports blanking (Blanking), the blanking source that can be configured to generate blanking can wake up the system

from low-power mode by generating interrupts, and COMP has the ability to wake up from STOP

- Configurable filter window size
- Configurable filter threshold size
- Configurable sampling frequency for filtering

## 16.3 COMP Configuration Precedure

The complete configuration items are as follows. If the default configuration is used, skip the corresponding configuration items.

1. Configurable hysteresis level COMP\_CTRL.HYST[1:0]
2. Configure the output polarity COMP\_CTRL.POL
3. Configure input selection, comparator non-inverting input COMP\_CTRL.INPSEL[3:0], inverting input COMP\_CTRL.INMSEL[2:0]
4. Configure COMP\_CTRL.OUTSEL[3:0] to choose output
5. Configure the blanking source COMP\_CTRL.BLKING[2:0]
6. Configure the filter sampling window COMP\_FILC.SAMPW[4:0]
7. Configure the threshold COMPx\_FILC.THRESH[4:0](threshold should be greater than COMPx\_FILC.SAMPW[4:0]/2)
8. Configure the filter sampling frequency(for timer applications, sampling frequency should be greater than 5MHz)
9. Enable COMPx\_FILC.FILEN filter
10. Enable COMPx\_CTRL.EN on the comparator

*Note: For the above steps, you need to turn on the filter enable first, and then turn on the comparator enable. The comparator enable needs to be enabled after the filter (if enabled) configuration and enable are completed. In addition, when the comparator control register is locked to LOCK, The lock can only be canceled by resetting.*

## 16.4 COMP Operating Mode

### 16.4.1 Independent Comparator

One comparator can be configured independently to complete the comparator function. The output of the comparator can be output to the IO port, the comparator supports different remapping ports, and the output of the comparator can be selected and connected to the corresponding port through configuration.

Comparator output can trigger events, for example, it can be configured for timer 1, timer 8 break functions.

*Note: Refer to the comparator interconnection for specific configuration.*

## 16.5 Comparator Interconnection

For the interconnection of the comparator output ports, please refer to the AFIO remapping chapter, Remap IO multiplexing function in GPIOx\_AFL/AFH.

COMP\_OUT can be mapped to PA0/PA6/PA11/PA12 Comparator INP pins have the following configuration:

| INPSEL | COMP             |
|--------|------------------|
| 00     | PA1              |
| 01     | PA3              |
| 10     | V <sub>REF</sub> |
| 11     | PA7              |

The comparator INM pins have the following configuration.

| INMSEL | COMP             |
|--------|------------------|
| 00     | V <sub>REF</sub> |
| 01     | PA0              |
| 10     | PA4              |
| 11     | PA5              |

Comparator output TRIG signal has the following interconnection.

| TRIG  | COMP                  |
|-------|-----------------------|
| 0000  | NC                    |
| 0001  | TIM1_BKIN             |
| 0010  | TIM1_IC1              |
| 0011  | TIM1_OCrefclear       |
| 0100  | TIM8_IC1              |
| 0101  | TIM8_OCrefclear       |
| 0110  | TIM3_IC1              |
| 0111  | TIM3_OCrefclear       |
| 1000  | --                    |
| 1001  | --                    |
| 1010  | --                    |
| 1011  | TIM1_BKIN + TIM8_BKIN |
| 1100  | TIM8_BKIN             |
| 1101  | LPTIM_ETR             |
| Other | --                    |

## 16.6 Interrupt

COMP supports interrupt response. There are two cases of interrupt generation as follows:

- COMP\_CTRL register sets the polarity of the POL bit is not reversed and the interrupt is enabled. When INPSEL > INMSEL, the comparator interrupt will be generated and the OUT bit of the COMP\_CTRL register is set to 1 by



hardware.

- COMP\_CTRL register sets the polarity of the POL bit is reversed and the interrupt is enabled. When INPSEL < INMSEL, the comparator interrupt will be generated and the OUT bit of the COMP\_CTRL register is set to 1 by hardware.

Note: The use of COMP interrupt needs to configure the EXTI line first, refer Table 6-1 Vector Table.

## 16.7 COMP Register

### 16.7.1 COMP Register Overview

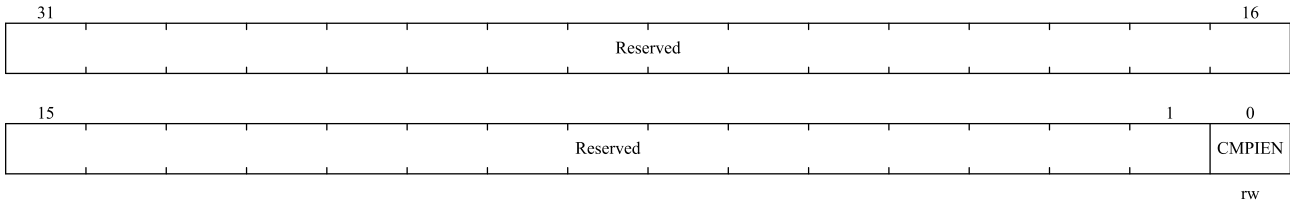
Table 16-1 COMP Register Overview

| Offset      | Register    | 31       | 30 | 29 | 28 | 27 | 26 | 25 | 24 | 23 | 22 | 21 | 20 | 19 | 18     | 17    | 16           | 15  | 14          | 13           | 12 | 11        | 10 | 9           | 8           | 7 | 6 | 5        | 4           | 3 | 2        | 1           | 0 |    |   |   |   |   |   |   |   |   |   |   |   |   |   |   |   |   |   |   |
|-------------|-------------|----------|----|----|----|----|----|----|----|----|----|----|----|----|--------|-------|--------------|-----|-------------|--------------|----|-----------|----|-------------|-------------|---|---|----------|-------------|---|----------|-------------|---|----|---|---|---|---|---|---|---|---|---|---|---|---|---|---|---|---|---|---|
| 000h        | COMP_INTEN  | Reserved |    |    |    |    |    |    |    |    |    |    |    |    |        |       |              |     |             |              |    |           |    |             |             |   |   |          |             |   |          | CMPIEN      |   |    |   |   |   |   |   |   |   |   |   |   |   |   |   |   |   |   |   |   |
|             | Reset Value |          |    |    |    |    |    |    |    |    |    |    |    |    |        |       |              |     |             |              |    |           |    |             |             |   |   |          |             |   |          | 0           |   |    |   |   |   |   |   |   |   |   |   |   |   |   |   |   |   |   |   |   |
| 03Ch        | COMP_INTSTS | Reserved |    |    |    |    |    |    |    |    |    |    |    |    |        |       |              |     |             |              |    |           |    |             |             |   |   |          |             |   |          | CMPIPS      |   |    |   |   |   |   |   |   |   |   |   |   |   |   |   |   |   |   |   |   |
|             | Reset Value |          |    |    |    |    |    |    |    |    |    |    |    |    |        |       |              |     |             |              |    |           |    |             |             |   |   |          |             |   |          | 0           |   |    |   |   |   |   |   |   |   |   |   |   |   |   |   |   |   |   |   |   |
| 008h        | Reserved    |          |    |    |    |    |    |    |    |    |    |    |    |    |        |       |              |     |             |              |    |           |    |             |             |   |   |          |             |   |          |             |   |    |   |   |   |   |   |   |   |   |   |   |   |   |   |   |   |   |   |   |
| 00Ch        | COMP_LOCK   | Reserved |    |    |    |    |    |    |    |    |    |    |    |    |        |       |              |     |             |              |    |           |    |             |             |   |   |          |             |   |          | CMPLK       |   |    |   |   |   |   |   |   |   |   |   |   |   |   |   |   |   |   |   |   |
|             | Reset Value |          |    |    |    |    |    |    |    |    |    |    |    |    |        |       |              |     |             |              |    |           |    |             |             |   |   |          |             |   |          | 0           |   |    |   |   |   |   |   |   |   |   |   |   |   |   |   |   |   |   |   |   |
| 010h        | COMP_CTRL   | Reserved |    |    |    |    |    |    |    |    |    |    |    |    | CLKSEL | PWRMD | Reserved     | OUT | BLKING[2:0] |              |    | HYST[1:0] |    | POL         | OUTTRG[3:0] |   |   | Reserved | INPSEL[1:0] |   | Reserved | INMSEL[1:0] |   | EN |   |   |   |   |   |   |   |   |   |   |   |   |   |   |   |   |   |   |
|             | Reset Value |          |    |    |    |    |    |    |    |    |    |    |    |    | 0      | 0     |              | 0   | 0           | 0            | 0  | 0         | 0  | 0           | 0           | 0 | 0 | 0        | 0           | 0 | 0        | 0           | 0 | 0  | 0 | 0 | 0 | 0 | 0 | 0 | 0 | 0 | 0 | 0 |   |   |   |   |   |   |   |   |
| 014h        | COMP_FILC   | Reserved |    |    |    |    |    |    |    |    |    |    |    |    |        |       |              |     |             | SAMPWIN[4:0] |    |           |    | THRESH[4:0] |             |   |   | FILEN    |             |   |          |             |   |    |   |   |   |   |   |   |   |   |   |   |   |   |   |   |   |   |   |   |
|             | Reset Value |          |    |    |    |    |    |    |    |    |    |    |    |    |        |       |              |     |             | 0            | 0  | 0         | 0  | 0           | 0           | 0 | 0 | 0        | 0           | 0 | 0        | 0           | 0 | 0  | 0 | 0 | 0 | 0 | 0 | 0 | 0 | 0 | 0 | 0 | 0 | 0 | 0 | 0 | 0 |   |   |   |
| 018h        | COMP_FILP   | Reserved |    |    |    |    |    |    |    |    |    |    |    |    |        |       | CLKPSC[15:0] |     |             |              |    |           |    |             |             |   |   |          |             |   |          |             |   |    |   |   |   |   |   |   |   |   |   |   |   |   |   |   |   |   |   |   |
|             | Reset Value |          |    |    |    |    |    |    |    |    |    |    |    |    |        |       | 0            | 0   | 0           | 0            | 0  | 0         | 0  | 0           | 0           | 0 | 0 | 0        | 0           | 0 | 0        | 0           | 0 | 0  | 0 | 0 | 0 | 0 | 0 | 0 | 0 | 0 | 0 | 0 | 0 | 0 |   |   |   |   |   |   |
| 01Ch ~ 03Ch | Reserved    |          |    |    |    |    |    |    |    |    |    |    |    |    |        |       |              |     |             |              |    |           |    |             |             |   |   |          |             |   |          |             |   |    |   |   |   |   |   |   |   |   |   |   |   |   |   |   |   |   |   |   |
| 040h        | COMP_INVREF | Reserved |    |    |    |    |    |    |    |    |    |    |    |    |        |       |              |     |             |              |    |           |    |             | VREFSEL     |   |   |          | VREFEN      |   |          |             |   |    |   |   |   |   |   |   |   |   |   |   |   |   |   |   |   |   |   |   |
|             | Reset Value |          |    |    |    |    |    |    |    |    |    |    |    |    |        |       |              |     |             |              |    |           |    |             | 0           | 0 | 0 | 0        | 0           | 0 | 0        | 0           | 0 | 0  | 0 | 0 | 0 | 0 | 0 | 0 | 0 | 0 | 0 | 0 | 0 | 0 | 0 | 0 | 0 | 0 | 0 | 0 |

### 16.7.2 COMP Interrupt Enable Register (COMP\_INTEN)

Address offset : 0x00

Reset value : 0x0000 0000

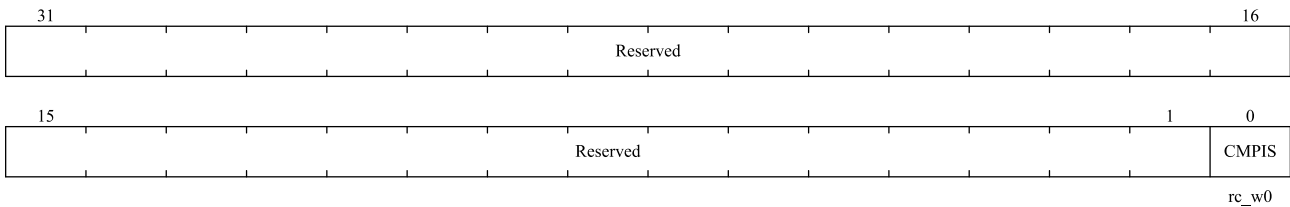


| Bit Field | Name     | Description                                      |
|-----------|----------|--|
| 31:1      | Reserved | Reserved, the reset value must be maintained     |
| 0         | CMPIEN   | COMP interrupt enable<br>0: disable<br>1: enable |

### 16.7.3 COMP Interrupt Register (COMP\_INTSTS)

Address offset : 0x04

Reset value : 0x0000 0000

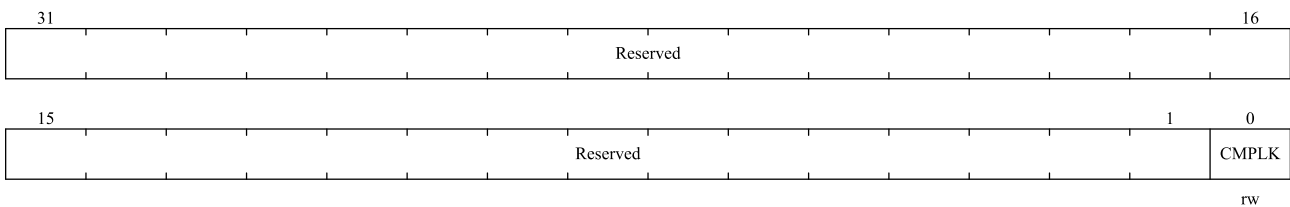


| Bit Field | Name     | Description                                  |
|-----------|----------|--|
| 31:1      | Reserved | Reserved, the reset value must be maintained |
| 0         | CMPIS    | interrupt status of COMP<br>Write 0 to clear |

### 16.7.4 COMP Lock Register (COMP\_LOCK)

Address offset : 0x0C

Reset value : 0x0000 0000



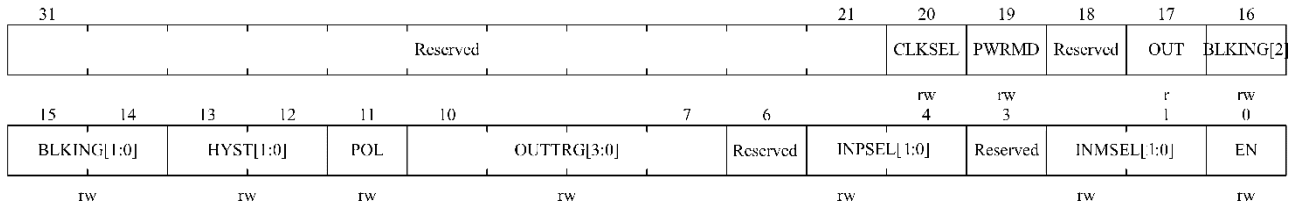
| Bit Field | Name     | Description  |
|-----------|----------|--|
| 31:1      | Reserved | Reserved, the reset value must be maintained   |
| 0         | Cmplk    | This bit can only be reset then written once by software. If software is set to 1, the COMP_CTRL register will become a read-only register<br>0: COMP_CTRL can be read and written |

| Bit Field | Name | Description            |
|-----------|------|------------------------|
|           |      | 1: COMP_CTRL read only |

### 16.7.5 COMP Control Register (COMP\_CTRL)

Address offset : 0x10

Reset value : 0x0000 0000



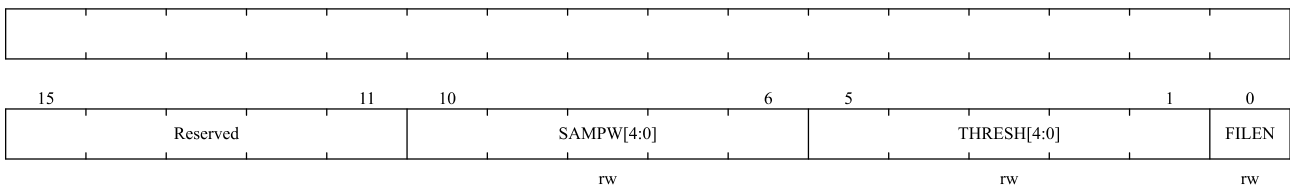
| Bit Field | Name        | Description   |
|-----------|-------------|---|
| 31:21     | Reserved    | Reserved, the reset value must be maintained  |
| 20        | CLKSEL      | COMP operating clock selection<br>0: System clock (SYSCLK)<br>1: Low-speed operating clock, can operate in STOP mode or LPRUN mode.   |
| 19        | PWRMD       | COMP power select<br>0: normal mode<br>1: Low power mode  |
| 18        | Reserved    | Reserved, the reset value must be maintained  |
| 17        | OUT         | This read-only bit is COMP output state.<br>0: Output is low<br>1: Output is high   |
| 16:14     | BLKING[2:0] | These bits select which Timer output controls the COMP output blanking.<br>000: No blanking<br>001: TIM1 OC5 selected as blanking source<br>010: TIM8 OC5 selected as blanking source<br>Other values: reserved |
| 13:12     | HYST[1:0]   | These bits control the hysteresis level.<br>00: No hysteresis<br>01: Low hysteresis<br>10: Medium hysteresis<br>11: High hysteresis   |
| 11        | POL         | This bit is used to invert the COMP output.<br>0: Output is not inverted<br>1: Output is inverted   |
| 10:7      | OUTTRG[3:0] | These bits select which Timer input must be connected with the COMP output.<br>0000: Reserved<br>0001: TIM1_BKIN<br>0010: TIM1_IC1  |

| Bit Field | Name        | Description  |
|-----------|-------------|--|
|           |             | 0011: TIM1_OCrefclear<br>0100: TIM8_IC1<br>0101: TIM8_OCrefclear<br>0110: TIM3_IC1<br>0111: TIM3_OCrefclear<br>1000: Reserved<br>1001: Reserved<br>1010: Reserved<br>1011: TIM1_BKIN+TIM8_BKIN<br>1100: TIM8_BKIN<br>1101: LPTIM_ETR<br>1110: Reserved<br>1111: Reserved |
| 6         | Reserved    | Reserved, the reset value must be maintained   |
| 5:4       | INPSEL[2:0] | COMP positive select<br>00: PA1<br>01: PA3<br>10: V <sub>REF</sub><br>11: PA7  |
| 3         | Reserved    | Reserved, the reset value must be maintained   |
| 2:1       | INMSEL[2:0] | COMP negative input select<br>00: V <sub>REF</sub><br>01: PA0<br>10: PA4<br>11: PA5  |
| 0         | EN          | This bit switches COMP ON/OFF.<br>0: disabled<br>1: enabled  |

**16.7.6 COMP Filter Control Register (COMP\_FILC)**

Address offset : 0x14

Reset value : 0x0000 0000



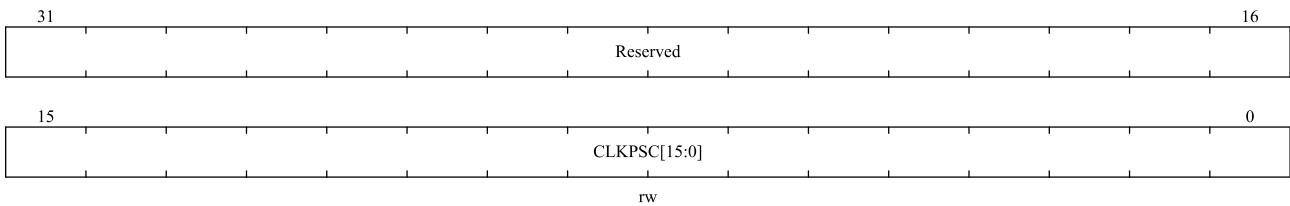
| Bit Field | Name     | Description                                  |
|-----------|----------|--|
| 31:11     | Reserved | Reserved, the reset value must be maintained |

| Bit Field | Name        | Description   |
|-----------|-------------|---|
| 10:6      | SAMPW[4:0]  | Filter sampling window size, sampling window = SAMPW + 1.   |
| 5:1       | THRESH[4:0] | The filter threshold is set. At least the sampling threshold of the opposite state in the sample window can change the output state. This value is required to be greater than SAMPW / 2. |
| 0         | FILEN       | Filter enable.<br>0: Disable<br>1: Enable   |

**16.7.7 COMP Filter Frequency Division Register (COMP\_FILP)**

Address offset : 0x18

Reset value : 0x0000 0000

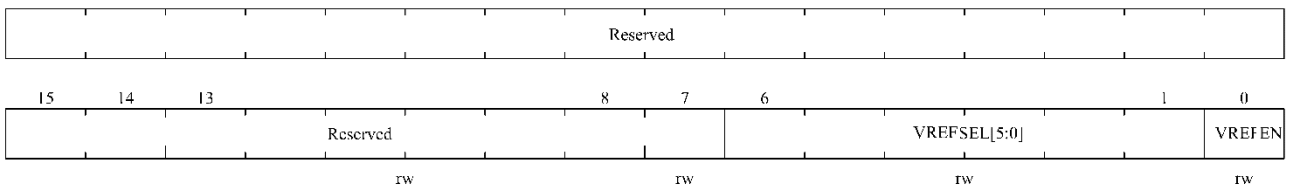


| Bit Field | Name         | Description  |
|-----------|--------------|--|
| 31:16     | Reserved     | Reserved, the reset value must be maintained   |
| 15:0      | CLKPSC[15:0] | Low filter sample clock prescale.<br>System clock divider = CLK_PRE_CYCLE + 1, e.g.<br>0: Every cycle<br>1: Every 2 cycle<br>2: Every 3 cycle<br>... |

**16.7.8 COMP Reference Input Compare Voltage Register (COMP\_INVREF)**

Address offset : 0x40

Reset value : 0x0000 0000



| Bit Field | Name         | Description   |
|-----------|--------------|---|
| 31:7      | Reserved     | Reserved, the reset value must be maintained  |
| 6:1       | VREFSEL[5:0] | Comparator reference input comparison voltage $V_{REF}$ gear selection 0~ $V_{DDA}$ , a total of 64 gears |

| Bit Field | Name   | Description  |
|-----------|--------|--|
| 0         | VREFEN | Comparator reference input compare voltage $V_{REF}$ enable<br>0: disable<br>1: enable |

## 17 I<sup>2</sup>C Interface

### 17.1 Introduction

The I<sup>2</sup>C(Inter-Integrated Circuit) bus is a widely used bus structure, it has only two bidirectional lines, the data bus SDA and clock bus SCL. All devices compatible with I<sup>2</sup>C bus can communicate directly with each other through I<sup>2</sup>C bus with these two lines.

I<sup>2</sup>C interface connects microcontroller and serial I<sup>2</sup>C bus, which can be used for communication between MCU and external I<sup>2</sup>C devices. It supports standard speed mode and fast mode, with CRC calculation and verification, and supports SMBus (System Management Bus) and PMBus (Power Management Bus), it also provides multi-host function to control all I<sup>2</sup>C bus specific timing, protocol, arbitration. I<sup>2</sup>C interface module also supports DMA mode, which can effectively reduce the burden on the CPU.

### 17.2 Main Features

- Multi-master function: this module can be used as master device or slave device;
- I<sup>2</sup>C master device function:
  - Generate a clock
  - Generate start and stop signals
- I<sup>2</sup>C slave device function:
  - Programmable address detection
  - The I2C interface supports 7-bit or 10-bit addressing and dual-slave address response capability in 7-bit slave mode.
  - Stop bit detection
- Generates and detects 7-bit /10-bit addresses and general calls;
- Supports different communication speeds
  - Standard speed (up to 100 kHz)
  - Fast (up to 400 kHz)
  - Fast+ (up to 1MHz)
- Status flags:
  - Transmitter/receiver mode flag
  - Byte transfer complete flag
  - I2C bus busy flag
- Error flags:
  - Arbitration loss in master mode

- Acknowledge (ACK) fail after address/data transfer
- Error start or stop condition detected
- Overrun or underrun when clock extending is disable
- One interrupt vector:
  - Event interrupts and error interrupts share one interrupt vector
- Optional extend clock function
- DMA of single-byte buffers;
- Generation or verification of configurable PEC (packet error checking)
  - In transmit mode, the PEC value can be transmitted as the last byte
  - PEC error check for the last received byte
- SMBus 2.0 compatible
  - Timeout delay for 25 ms clock low
  - 10 ms accumulates low clock extension time of master device
  - 25 ms accumulates low clock extension time of slave device
  - PEC generation/verification of hardware with ACK control
  - Supports address resolution protocol (ARP)
  - Compatible with the PMBus

*Note: Not all features mentioned above are included in every product. Please refer to the relevant datasheet to confirm the I2C functionality supported by this product.*

## 17.3 Function Description

The I<sup>2</sup>C interface is connected to I<sup>2</sup>C bus through data pin (SDA) and clock pin (SCL) to communicate with external devices. It can be connected to standard (up to 100kHz) or fast (up to 400kHz) or fast<sup>+</sup>(up to 1MHz) I<sup>2</sup>C bus. I<sup>2</sup>C module converts data from serial to parallel when receiving, and converts data from parallel to serial when transmitting. It supports interrupt mode, users can enable or disable interrupt according to their needs.

### 17.3.1 SDA and SCL Line Control

I<sup>2</sup>C module has two interface lines: serial data line (SDA) and serial clock line (SCL). Devices connected to the bus and exchange information through these two wires. Both SDA and SCL are bidirectional lines, it should be connected to positive power supply via a pull-up resistor or a current source. When the bus is idle, both lines are high level. The output of device which is connected to the bus must have open drain or open collector to provide wired-AND functionality. The data on I<sup>2</sup>C bus can reach 100 kbit/s in standard mode and 1000 kbit/s in fast mode. Since devices of different processors may be connected to the I<sup>2</sup>C bus, the levels of logic '0' and logic '1' are not fixed and depend on the actual level of V<sub>DD</sub>.

If the clock stretching is allowed, the SCL line is pulled down which can be avoided the overload error during receiving and the under load error during transmission.



For example, when in the transmission mode, if the transmit data register is empty and the byte transmit end bit is set ( $I2C\_STS1.TXDATE = 1$ ,  $I2C\_STS1.BSF = 1$ ), the I<sup>2</sup>C interface keeps the clock line low before transmission to wait for the software to read STS1 and write the data into the data register (both buffer and shift register are empty); when In the receive mode, if the data register is not empty and the byte transmitting end bit is set ( $I2C\_STS1.RXDATNE = 1$ ,  $I2C\_STS1.BSF = 1$ ), the I<sup>2</sup>C interface keeps the clock line low after receiving the data byte, waiting for the software to read STS1, and then read the data register(buffer and shift register are full).

In the receive mode, if clock stretching is disable in slave mode and the receive data register is not empty ( $I2C\_STS1.RXDATNE = 1$ ), and the data has not been read before receiving the next byte, an overrun error will issue and the last word byte will be discarded. In transmit mode, if the transmit data register is empty ( $I2C\_STS1.TXDATE = 1$ ), no new data is written into the data register before the next byte must be sent, an underrun error will issue. The same byte will be transmitted repeatedly. In this case, duplicate write conflicts are not controlled.

### 17.3.2 Software Communication Process

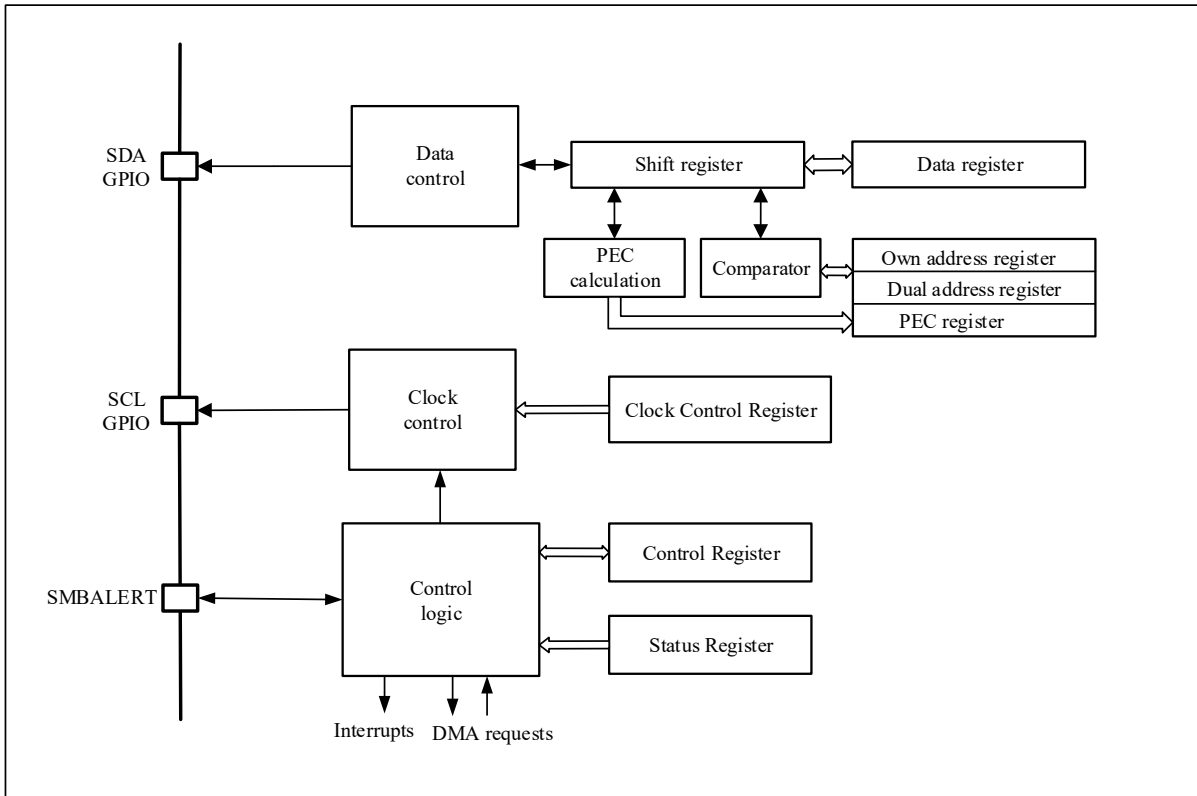
The data transmission of I<sup>2</sup>C device is divided into master and slave. Master is the device responsible for initializing the transmission of data on the bus and generating clock signal. At this time, any addressed device is a slave. Whether the I<sup>2</sup>C device is a master or a slave, it can transmit or receive data. Therefore, the I<sup>2</sup>C interface supports four operation modes:

- Slave transmitter mode
- Slave receiver mode
- Master transmitter mode
- Master receiver mode

After system reset, I<sup>2</sup>C operates in slave mode by default. The I<sup>2</sup>C interface is configured by software to transmit a start bit on the bus, and then the interface automatically switches from the slave mode to the master mode. When arbitration is lost or a stop signal is generated, the interface will switched to the slave mode from the master mode.

The block diagram of I<sup>2</sup>C interface is shown in the figure below.

Figure 17-1 I<sup>2</sup>C Functional Block Diagram

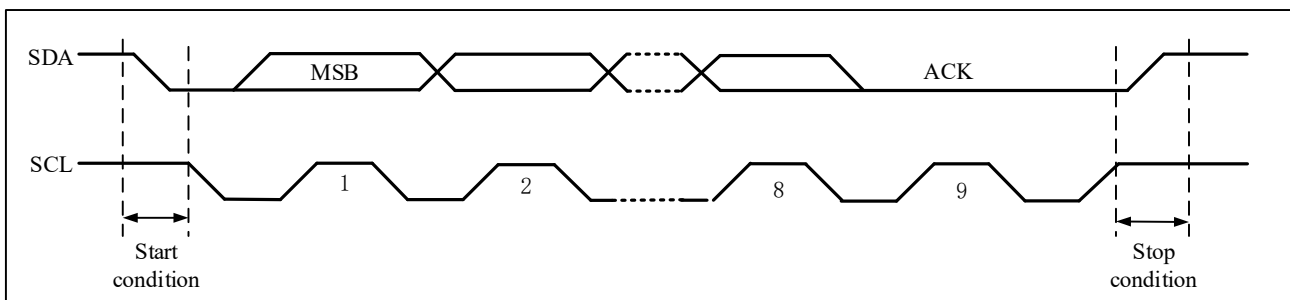


Note: in SMBus mode, SMBALERT is an optional signal. If SMBus is disabled, the signal cannot be used

17.3.2.1 Start and stop conditions

All data transfers always start with the start bit and end with the stop bit. The start and stop conditions are generated by software in the master mode. Start bit is a level conversion from high to low on SDA line when SCL is high. Stop bit is a level transition from low to high on SDA line when SCL is high. as shown in the figure below.

Figure 17-2 I<sup>2</sup>C Bus Protocol



17.3.2.2 Clock synchronization and arbitration

The I<sup>2</sup>C module supports multi-master arbitration, which means two masters can initiate an I<sup>2</sup>C start operation concurrently when the bus is inactive. So some mechanisms are needed to grant a master the access to the bus. This process is generally named clock synchronization and arbitration.

I<sup>2</sup>C module has two key features:

- SDA and SCL are drain open-drain configurations, and the signal "wire-AND" logic is realized through an external pull-up resistor.
- SDA and SCL pins will also detect the level on the pin while outputting the signal to check whether the output is consistent with the previous output. This provides the hardware basis for "Clock Synchronization" and "Bus Arbitration".

The I<sup>2</sup>C device on the bus is to output logic 0 by "grounding the line". Based on the characteristics of the I<sup>2</sup>C bus, if one device transmits logic 0 and the other transmits logic 1, then the line sees only logic 0, so there is no possibility of level conflicts on the line.

The physical connection of the bus allows the master to read data while writing data to the bus. In this way, when two masters are competing for the bus, the one that transmits logic 0 does not know the occurrence of the competition. Only the one that transmits logic 1 will find the conflict (when writing a logic 1, but read 0) and exit the competition.

### **Clock synchronization**

The high-to-low switching of the SCL line causes the devices to begin counting their low-level periods, and once the device's clock goes low, it keeps the SCL line in this state until the high-level of the clock is reached. However, if another clock is still in the low period, the low-to-high switch of this clock will not change the state of the SCL line. Therefore, the SCL line is kept low by the device with the longest low-level period. A device with a short low-level period will enter a high-level wait state.

When all related devices have counted their low-level periods, the clock line is released and goes high-level, after which there is no difference in the state of the device clock and SCL lines, and all devices will begin counting their high-level periods, the device that completes the high-level period first will pull the SCL line low again.

In this way, the low-level period of the generated synchronous SCL clock is determined by the device with the longest low-level clock period, and the high-level period is determined by the device with the shortest high-level clock period.

### **Arbitration**

Arbitration, like synchronization, is to resolve bus control conflicts in the case of multiple masters. The arbitration process has nothing to do with the slave. When the two masters both produce a valid start bit when the bus is idle, in this case, it is necessary to decide which master will complete the data transmission. This is the process of arbitration.

Each master controller does not have the priority level of controlling the bus, which is all determined by arbitration. The bus control is determined and carried out bit by bit. They follow the principle of "low level first", that is, whoever transmits the low level first will control the bus. During the arbitration of each bit, when SCL is high, each host checks whether its own SDA level is the same as that sent by itself. In theory, if the content transmitted by two hosts is exactly the same, then they can successfully transmit without errors. If a host transmits a high level but detects that the SDA line is low, it considers that it has lost arbitration and shuts down its SDA output driver, while the other host continues to complete its own transmission.

### **17.3.2.3 I<sup>2</sup>C data communication process**

Each I<sup>2</sup>C device is identified by a unique address. According to the device function, they can function as both transmitter and receiver.

The I<sup>2</sup>C host is responsible for generating the start bit and the end bit in order to start and end a transmission. And is responsible for generating the SCL clock.

The I<sup>2</sup>C module supports 7-bit and 10-bit addresses, and the user can configure the address of the I<sup>2</sup>C slave through software. After the I<sup>2</sup>C slave detects the start bit on the I<sup>2</sup>C bus, it starts to receive the address from the bus, and compares the received address with its own address. Once the two addresses are matched, the I<sup>2</sup>C slave will transmit an acknowledgement (ACK) and respond to subsequent commands on the bus: transmit or receive the requested data. In addition, if the software opens a broadcast call, the I<sup>2</sup>C slave always transmits a confirmation response to a broadcast address (0x00).

Data and address are transmitted in 8-bit width, with the most significant bit first. The 1 or 2 bytes following the start condition is the address (1 byte in 7-bit mode, 2 bytes in 10-bit mode). The address is only sent in master mode. During the 9th clock period after 8 clocks of a byte transmission, the receiver must transmit back an acknowledge bit (ACK) to the transmitter, as shown in the Figure 17-2 I<sup>2</sup>C Bus Protocol.

Software can enable or disable acknowledgement (ACK), and can set the I<sup>2</sup>C interface address (7-bit, 10-bit address or general call address).

#### 17.3.2.4 I<sup>2</sup>C slave transmission mode

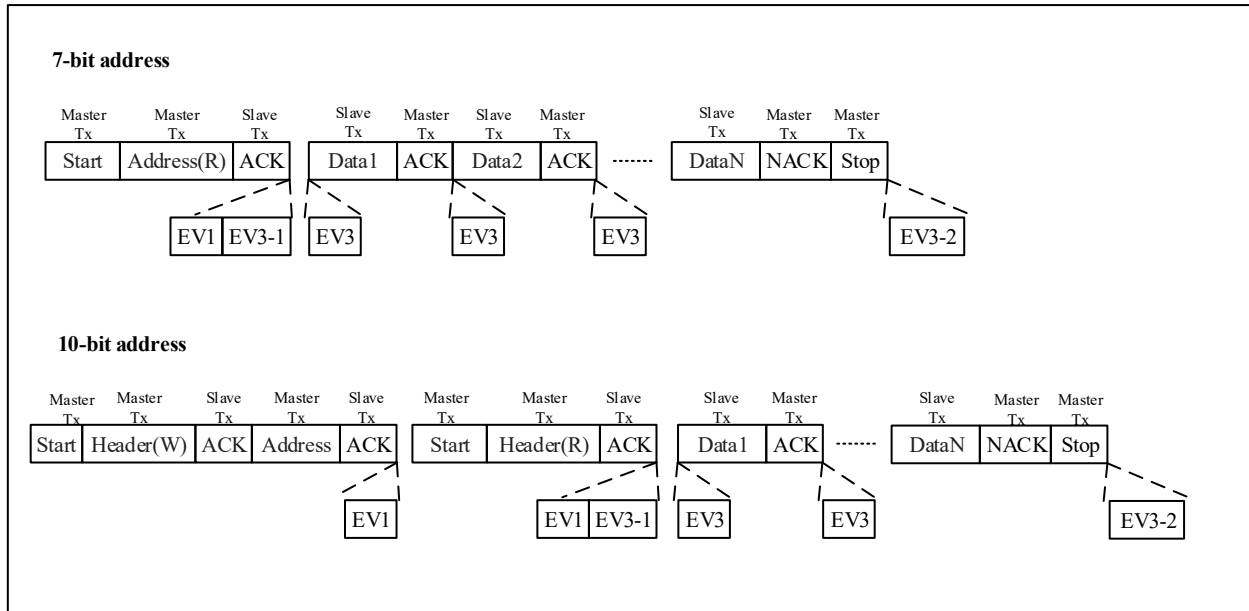
In slave mode, the transmission reception flag bit (I2C\_STS2.TRF) indicates whether it is currently in receiver mode or transmission mode. When transmitting data to I<sup>2</sup>C bus in transmission mode, the software configurations should follow the following steps:

1. First, enable I<sup>2</sup>C peripheral clock and configure the clock related register in I2C\_CTRL1, ensuring the correct I<sup>2</sup>C timing. After these two steps are completed, I<sup>2</sup>C runs in slave mode, waiting for receiving start bit and address.
2. I<sup>2</sup>C slave receives a start bit first, and then receives a matching 7-bit or 10-bit address. I<sup>2</sup>C hardware will set the I2C\_STS1.ADDRF(received address and matched its own address). The software should monitor this bit regularly or have an interrupt to monitor this bit. After this bit is set, the software reads I2C\_STS1 register and then read I2C\_STS2 register to clear the I2C\_STS1.ADDRF bit. If the address is in 10 bit format, the I<sup>2</sup>C master should then generate a start bit and transmit an address header to the I<sup>2</sup>C bus. After detecting start bit and the following address header, the slave will continue to set I2C\_STS1.ADDRF bit. The software continues to read I2C\_STS1 register and read I2C\_STS2 register to clear the I2C\_STS1.ADDRF bit a second time.
3. I<sup>2</sup>C enters the data transmitting state, and now shift register and data register I2C\_DAT are all empty, so the hardware will set the I2C\_STS1.TXDATE(transmit data empty). At this time, the software can write the first byte data to I2C\_DAT register, however, because the byte of the I2C\_DAT register is immediately moved into the internal shift register, the I2C\_STS1.TXDATE bit is not cleared to zero. When the shift register is not empty, I<sup>2</sup>C starts to transmit data to I<sup>2</sup>C bus.
4. During the transmission of the first byte, the software writes the second byte to I2C\_DAT, neither the I2C\_DAT register nor the shift register is empty. The I2C\_STS1.TXDATE bit is cleared to 0.
5. After the first byte is sent, I2C\_STS1.TXDATE is set again, and the software writes the third byte to I2C\_DAT, the same time, the I2C\_STS1.TXDATE bit is cleared. After that, as long as there is still data to be sent and I2C\_STS1.TXDATE is set to 1, the software can write a byte to I2C\_DAT register.
6. During the transmitting of the second last byte, the software writes the last data to the I2C\_DAT register to clear the I2C\_STS1.TXDATE flag bit, and then the I2C\_STS1.TXDATE status is no longer concerned. The

I2C\_STS1.TXDATE bit is set after the second last byte is sent until the stop end bit is detected.

7. According to the I<sup>2</sup>C protocol, the I<sup>2</sup>C master will not transmit a ACK to the last byte received. Therefore, after the last byte is sent, the I2C\_STS1.ACKFAIL bit (acknowledge fail) of the I<sup>2</sup>C slave will be set to notify the software of the end of transmitting. The software writes 0 to the I2C\_STS1.ACKFAIL bit to clear this bit.

Figure 17-3 Slave Transmitter Transfer Sequence Diagram



Instructions:

1. EV1: I2C\_STS1.ADDRF = 1, reading STS1 and then reading STS2 to clear the event.
2. EV3-1: I2C\_STS1.TXDATE=1, shift register is empty, data register is empty, writing DAT.
3. EV3: I2C\_STS1.TXDATE=1, shift register is not empty, data register is empty, writing DAT will clear the event.
4. EV3-2: I2C\_STS1.ACKFAIL=1, write '0' to ACKFAIL bit of STS1 register to clear the event.

Note: (1) EV1 and EV3\_1 event prolongs the low SCL time until the end of the corresponding software sequence.

(2) The software sequence of EV3 must be completed before the end of the current byte transfer.

### 17.3.2.5 I<sup>2</sup>C slave receiving mode

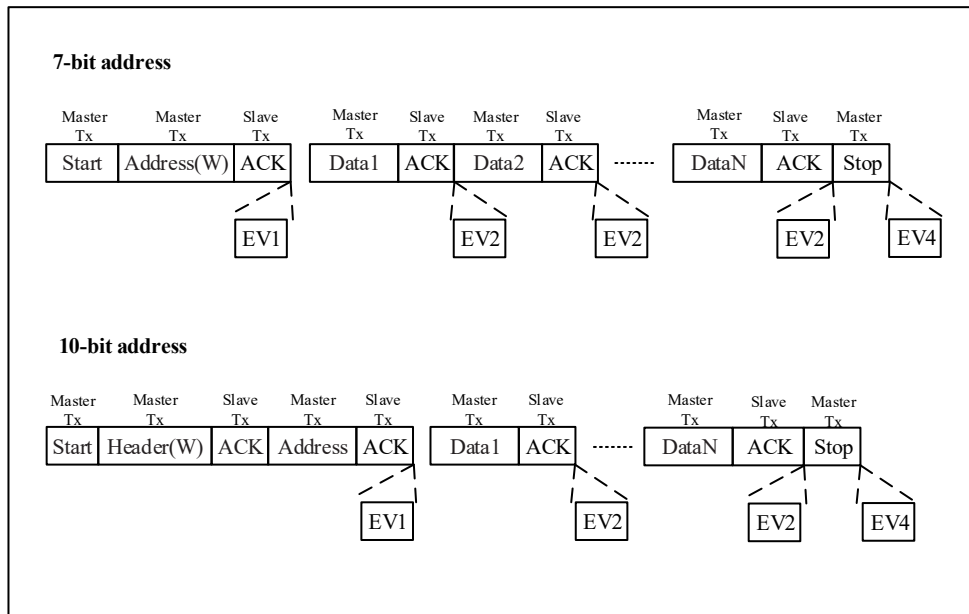
When receiving data in slave mode, the software configurations should follow the following steps:

1. First, enable I<sup>2</sup>C peripheral clock and configure the clock related register in I2C\_CTRL1 ensuring the correct I<sup>2</sup>C timing. After these two steps are completed, I<sup>2</sup>C runs in slave mode, waiting for receiving start bit and address.
2. After receiving the start condition and the matched 7-bit or 10-bit address, I<sup>2</sup>C hardware will set I2C\_STS1.ADDRF bit(the address received and matched with its own address) to 1. This bit should be detected by software polling or interrupt. After it is found that it is set, the software clears the I2C\_STS1.ADDRF bit by reading I2C\_STS1 register first and then I2C\_STS2 register. Once the I2C\_STS1.ADDRF bit is cleared, The I<sup>2</sup>C slave starts to receive data from the I<sup>2</sup>C bus.
3. When the first byte is received, the I2C\_STS1.RXDATNE bit (the received data is not empty) is set to 1 by hardware.

If the I2C\_CTRL2.EVTINTEN and I2C\_CTRL2.BUFINTEN bits are set, an interrupt is generated. The software should check this bit by polling or interrupt. Once it is found that it is set, the software can read the first byte of I2C\_DAT register, and then the I2C\_STS1.RXDATNE bit is cleared to 0. Note that if the I2C\_CTRL1.ACKEN bit is set, after receiving a byte, the slave should generate a response pulse.

4. At any time, as long as the I2C\_STS1.RXDATNE bit is set to 1, the software can read a byte from the I2C\_DAT register. When the last byte is received, I2C\_STS1.RXDATNE is set to 1 and the software reads the last byte.
5. When the slave detects the STOP bit on I<sup>2</sup>C bus, set I2C\_STS1.STOPF to 1, and if the I2C\_CTRL2.EVTINTEN bit is set, an interrupt will be generated. The software clears the I2C\_STS1.STOPF bit by reading the I2C\_STS1 register before writing the I2C\_CTRL1 register (see EV4 in the following figure).

**Figure 17-4 Slave Receiver Transfer Sequence Diagram**



**Instructions:**

1. EV1: I2C\_STS1.ADDRF = 1, reading STS1 and then reading STS2 to clear the event.
2. EV2: I2C\_STS1.RXDATNE =1, reading DAT will clear this event.
3. EV4: I2C\_STS1.STOPF=1, reading STS1 and then writing the CTRL1 register will clear this event.

**Notes:**

- (1) EV1 event prolongs the time when SCL is low until the end of the corresponding software sequence.
- (2) The software sequence of EV2 must be completed before the end of the current byte transmission.

**17.3.2.6 I<sup>2</sup>C master transmission mode**

In the master mode, the I<sup>2</sup>C interface starts data transmission and generates the clock signal. Serial data transmission always starts with a start condition and ends with a stop condition. When the start condition is generated on the bus through the start bit, the device enters the master mode.

When transmitting data to I<sup>2</sup>C bus in master mode, the software configurations should follow the following steps:

1. First, enable the I<sup>2</sup>C peripheral clock, and configure the clock-related registers in I2C\_CTRL1 to ensure the correct I<sup>2</sup>C timing. When these two steps are completed, I<sup>2</sup>C runs in the slave mode by default, waiting for receiving the start bit and address.
2. When BUSY=0, I2C\_CTRL1.STARTGEN bit set to 1, and the I<sup>2</sup>C interface will generate a start condition and switch to the master mode (I2C\_STS2.MSMODE=1).
3. Once the start condition is issued, I<sup>2</sup>C hardware will set I2C\_STS1.STARTBF bit(start bit flag)and then enters the master mode. If the I2C\_CTRL2.EVTINTEN bit is set, an interrupt will be generated. Then the software reads the I2C\_STS1 register and then writes a 7-bit address bit or a 10-bit address bit with an address header to the I2C\_DAT register to clear the I2C\_STS1.STARTBF bit. After the I2C\_STS1.STARTBF bit is cleared to 0, I<sup>2</sup>C starts transmitting addresses or address headers to I<sup>2</sup>C bus.

In 10-bit address mode, transmitting a header sequence will generate the following events:

- I2C\_STS1.ADDR10F bit is set by hardware, and if I2C\_CTRL2.EVTINTEN bit is set, an interrupt is generated. Then the master reads the STS1 register, and then writes the second address byte into the DAT register.
- I2C\_STS1.ADDRF bit is set by hardware, and if I2C\_CTRL2.EVTINTEN bit is set, an interrupt is generated. Then the master reads the STS1 register, followed by the STS2 register.

*Note: in the transmitter mode, the master device first transmits the header byte (11110xx0) and then transmits the lower 8 bits of the slave address. (where xx represents the highest 2 bits of the 10-bit address).*

In the 7-bit address mode, only one address byte needs to be sent out. Once the address byte is sent out:

- I2C\_STS1.ADDRF bit is set by hardware, and if I2C\_CTRL2.EVTINTEN bit is set, an interrupt is generated. Then the master device waits for reading the STS1 register once, followed by reading the STS2 register.

*Note: in the transmitter mode, when the master transmits the slave address, set the lowest bit to "0".*

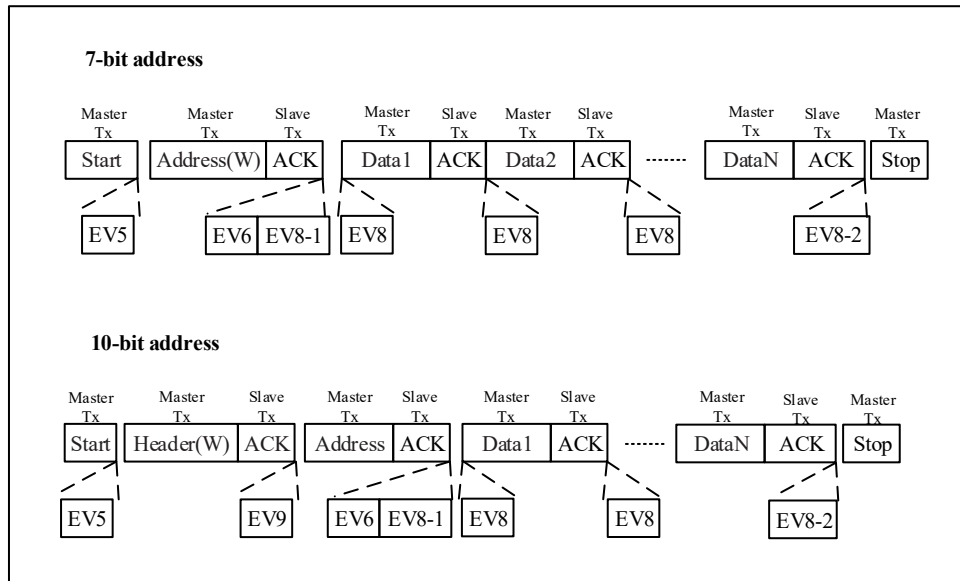
*Note: in the 7-bit address mode, do not configure the slave address as 0xF0 to prevent hardware from setting the I2C\_STS1.ADDR10F bit.*

4. After the 7-bit or 10-bit address bit is sent, the I<sup>2</sup>C hardware sets the I2C\_STS1.ADDRF bit (address has been sent) to 1, if the I2C\_CTRL2.EVTINTEN bit is set, an interrupt is generated, and the software is cleared by reading the I2C\_STS1 register and then the I2C\_STS2 register I2C\_STS1.ADDRF.
5. I<sup>2</sup>C enters the data transmission state. Because the shift register and the data register (I2C\_DAT) are empty, the hardware sets the I2C\_STS1.TXDATE bit (transmission data empty) to 1, and then the software writes the first byte of data to the I2C\_DAT register, but because the byte written into the I2C\_DAT register is immediately moved into the internal shift register, the I2C\_STS1.TXDATE bit will not be cleared at this time. Once the shift register is not empty, I<sup>2</sup>C starts transmitting data to the bus.
6. During the transmission of the first byte, the software writes the second byte to I2C\_DAT, and I2C\_STS1.TXDATE is cleared at this time. At any time, as long as there is data waiting to be sent and the I2C\_STS1.TXDATE bit is set to 1, the software can write a byte to the I2C\_DAT register.
7. In the process of transmitting the penultimate byte, the software writes the last byte of data to I2C\_DAT to clear the I2C\_STS1.TXDATE flag bit. After that, there is no need to care about the status of the I2C\_STS1.TXDATE bit. The I2C\_STS1.TXDATE bit will be set after the penultimate byte is sent, and will be cleared when the stop bit (STOP) is

sent.

- After the last byte is sent, because the shift register and the I2C\_DAT register are empty at this time, the I<sup>2</sup>C host sets the I2C\_STS1.BSF bit (byte transmission end), and the I<sup>2</sup>C interface will keep SCL low before clearing the I2C\_STS1.BSF bit. After reading I2C\_STS1, writing to the I2C\_DAT register will clear the I2C\_STS1.BSF bit. The software sets the I2C\_CTRL1.STOPGEN bit at this time to generate a stop condition, and then the I<sup>2</sup>C interface will automatically return to the slave mode (I2C\_STS2.MSMODE bit is cleared).

Figure 17-5 Master Transmitter Transfer Sequence Diagram



Instructions:

- EV5: I2C\_STS1.STARTBF = 1, reading STS1 and writing the address to the DAT register will clear the event.
- EV6: I2C\_STS1.ADDRF = 1, reading STS1 and then reading STS2 to clear the event.
- EV8\_1: I2C\_STS1.TXDATE = 1, shift register is empty, data register is empty, write DAT register.
- EV8: I2C\_STS1.TXDATE = 1, shift register is not empty, data register is empty, write to DAT register will clear the event.
- EV8\_2: I2C\_STS1.TXDATE = 1, I2C\_STS1.BSF = 1, request to set stop bit. These two events are cleared by the hardware when a stop condition is generated.
- EV9: I2C\_STS1.ADDR10F = 1, reading STS1 and then writing DAT register to clear the event.

Notes:

- (1) EV5, EV6, EV9, EV8\_1 and EV8\_2 event prolonged the low SCL time until the end of the corresponding software sequence.
- (2) The software sequence of EV8 must be completed before the end of the current byte transfer.
- (3) When I2C\_STS1.TXDATE or I2C\_STS1.BSF bit is set, stop condition should be arranged when EV8\_2 occurs.



### 17.3.2.7 I<sup>2</sup>C master receiving mode

In master mode, when receiving data from I<sup>2</sup>C bus, the software configurations should follow the following steps:

1. First, enable the I<sup>2</sup>C peripheral clock and configure the clock-related registers in I2C\_CTRL1, in order to ensure that the correct I<sup>2</sup>C timing is output. After enabling and configuring, I<sup>2</sup>C runs in slave mode by default, waiting to receive the start bit and address.
2. When BUSY=0, set the I2C\_CTRL.STARTGEN bit, and the I<sup>2</sup>C interface will generate a start condition and switch to the master mode (I2C\_STS2.MSMODE bit is set to 1).
3. Once the start condition is issued, the I<sup>2</sup>C hardware sets I2C\_STS1.STARTBF(start bit flag) and enters the host mode. If the I2C\_CTRL2.EVTINTEN bit is set to 1, an interrupt will be generated. Then the software reads the I2C\_STS1 register and then writes a 7-bits address or a 10-bits address with an address header to the I2C\_DAT register, in order to clear the I2C\_STS1.STARTBF bit. After the I2C\_STS1.STARTBF bit is cleared to 0, I<sup>2</sup>C begins to transmitting the address or address header to the I<sup>2</sup>C bus.

In 10-bits address mode, transmitting a header sequence will generate the following events:

- The I2C\_STS1.ADDR10F bit is set to 1 by hardware, and if the I2C\_CTRL2.EVTINTEN bit is set to 1, an interrupt will be generated. Then the master device reads the STS1 register, and then writes the second byte of address into the DAT register.
- The I2C\_STS1.ADDRF bit is set to 1 by hardware, and if the I2C\_CTRL2.EVTINTEN bit is set to 1, an interrupt will be generated. Then the master device reads the STS1 register and the STS2 register in sequence.

*Note: in the receiver mode, the master device transmits the header byte (11110xx0) firstly, then transmits the lower 8 bits of the slave address, and then retransmits a start condition followed by the header byte (11110xx1) (where xx represents the highest 2 digits of the 10-bits address).*

In the 7-bits address mode, only one address byte needs to be sent, once the address byte is sent:

- The I2C\_STS1.ADDRF bit is set to 1 by hardware, and if the I2C\_CTRL2.EVTINTEN bit is set to 1, an interrupt will be generated. Then the master device waits to read the STS1 register once, and then reads the STS2 register.

*Note: in the receiving mode, the master device sets the lowest bit as '1' when transmitting the slave address.*

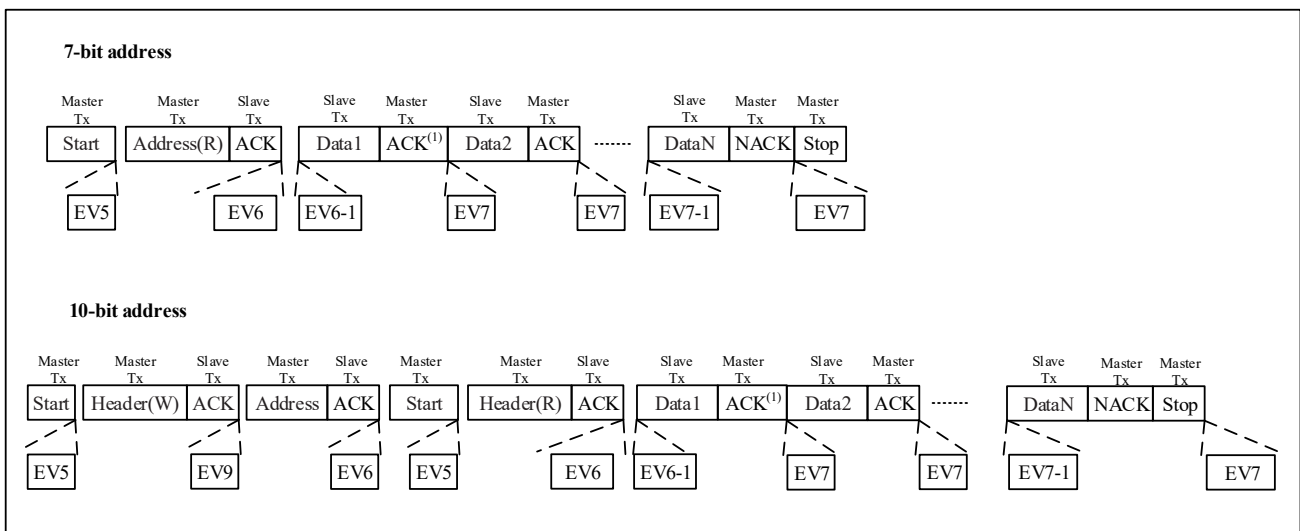
4. After the 7-bits or 10-bits address is sent, the I<sup>2</sup>C hardware sets the I2C\_STS1.ADDRF bit (address has been sent) to 1. If the I2C\_CTRL2.EVTINTEN bit is set to 1, an interrupt will be generated. The software clears the I2C\_STS1.ADDRF bit by reading the I2C\_STS1 register and the I2C\_STS2 register in sequence. If in the 10-bit address mode, software should set the I2C\_CTRL1.STARTGEN bit again to regenerate a START. After the START is generated, the I2C\_STS1.STARTBF bit will be set. The software should clear the I2C\_STS1.STARTBF bit by reading I2C\_STS1 firstly and then writing the address header to I2C\_DAT, and then the address header is sent to the I<sup>2</sup>C bus, I2C\_STS1.ADDRF is set to 1 again. The software should clear the I2C\_STS1.ADDRF bit again by reading I2C\_STS1 and I2C\_STS2 in sequence.
5. After transmitting the address and clearing the I2C\_STS1.ADDRF bit, the I<sup>2</sup>C interface enters the host receiving mode. In this mode, the I<sup>2</sup>C interface receives data bytes from the SDA line and transmits them to the DAT register through the internal shift register. Once the first byte is received, the hardware will set the I2C\_STS1.RXDATNE bit (not empty flag bit of received data) to 1, and if the I2C\_CTRL1.ACKEN bit is set

to 1, an acknowledge pulse will be sent. At this time, the software can read the first byte from the I2C\_DAT register, and then the I2C\_STS1.RXDATNE bit is cleared to 0. After that, as long as I2C\_STS1.RXDATNE is set to 1, the software can read a byte from the I2C\_DAT register.

6. The master device transmits a NACK after receiving the last byte from the slave device. After receiving the NACK, the slave device releases the control of SCL and SDA lines; the master device can transmit a stop/restart condition. In order to generate a NACK pulse after receiving the last byte, the software should clear the I2C\_CTRL1.ACKEN bit immediately after receiving the penultimate byte (N-1). In order to generate a stop/restart condition, the software must set the I2C\_CTRL1.STOPGEN bit or I2C\_CTRL1.STARTGEN to 1 after reading the penultimate data byte. This process needs to be completed before the last byte is received to ensure that the NACK is sent for the last byte.
7. After the last byte is received, the I2C\_STS1.RXDATNE bit is set to 1, and the software can read the last byte. Since I2C\_CTRL1.ACKEN has been cleared to 0 in the previous step, I<sup>2</sup>C no longer transmits ACK for the last byte, and generates a STOP bit after the last byte is sent.

*Note: the above steps require the number of bytes N>1. If N=1, step 6 should be executed after step 4, and it needs to be completed before the reception of byte is completed.*

**Figure 17-6 Master Receiver Transfer Sequence Diagram**



**Instructions:**

1. EV5: I2C\_STS1.STARTBF=1, reading STS1 and then writing the address into the DAT register will clear this event.
2. EV6: I2C\_STS1.ADDRF=1, reading STS1 and STS2 in sequence will clear this event. In the 10-bits master receiving mode, the I2C\_CTRL1.STARTGEN should be set to 1 after this event.
3. EV6\_1: There is no corresponding event flag, only suitable for receiving 1 byte. Just after EV6 (that is after clearing I2C\_STS1.ADDRF), the generation bits for acknowledge and stop condition should be cleared.
4. EV7: I2C\_STS1.RXDATNE=1, reading the DAT register to clear this event.
5. EV7\_1: I2C\_STS1.RXDATNE =1, reading the DAT register to clear this event. Set I2C\_CTRL1.ACKEN=0 and I2C\_CTRL1.STOPGEN=1.
6. EV9: I2C\_STS1.ADDR10F=1, reading STS1 and then writing to the DAT register will clear this event.

Notes:

- (1) If a single byte is received, it is NA.
- (2) EV5, EV6, and EV9 events extend the low level of SCL until the corresponding software sequence ends.
- (3) The EV7 software sequence shall be completed before the end of the current byte transmission.
- (4) The software sequence of EV6\_1 or EV7\_1 shall be completed before the ACK pulse of the current transmission byte.

### 17.3.3 Error Conditions Description

I<sup>2</sup>C errors mainly include bus error, acknowledge error, arbitration loss, overload/underload error. These errors may cause communication failure.

#### 17.3.3.1 Acknowledge failure(ACKFAIL)

The interface have a acknowledge bit is detected that does not match the expectation, it will occurs acknowledge fail error, and the I2C\_STS1.ACKFAIL bit is set. An interrupt occurs when I2C\_CTRL2.ERRINTEN bit is set to 1.

When transmitter receives a NACK, the communication must be reset: if the device is in slave mode, hardware will release the bus; if the device is in master mode, it must generate a stop condition from software.

#### 17.3.3.2 Bus error(BUSERR)

When address or data is transmitting, I<sup>2</sup>C interface receive external stop or start condition, it will happen a bus error, I2C\_STS1. BUSERR bit is set. An interrupt occurs when I2C\_CTRL2.ERRINTEN bit is set to 1.

In master mode, the hardware does not release bus and does not affect the current status of transfer. It is up to the software to decide whether to abort the current transfer.

In slave mode, when data is discarded in transmission and the bus releases by hardware, it will have two situation: if an error start condition is detected, the slave device considers a restart condition and waits for an address or a stop condition. If an error stop condition is detected, the slave device operates as a normal stop condition and the hardware releases the bus.

#### 17.3.3.3 Arbitration lost(ARLOST)

When the I<sup>2</sup>C interface detects arbitration loss, an arbitration loss error occurs, the hardware releases the bus, and the I2C\_STS1.ARLOST bit is set. If the I2C\_CTRL2.ERRINTEN bit is set to "1", an interrupt is generated. I<sup>2</sup>C interface will go to slave mode automatically(I2C\_STS2.MSMODE bit is cleared). When the I<sup>2</sup>C interface loses the arbitration, it can not respond to its slave address, but it can respond after winning the bus when the master retransmits a start signal.

#### 17.3.3.4 Overrun/Underrun error(OVERRUN)

In slave mode, disabling clock extend can lead to overrun/underrun error:

When I<sup>2</sup>C interface is receiving data (I2C\_STS1.RXDATNE=1, data have received in register), and I2C\_DAT register still have previous byte has not been read, it will occurs an overrun error. In this situation, the last received data is discarded. And software should clear I2C\_STS1.RXDATNE bit, and the transmitter will retransmit the last byte sent.

When I<sup>2</sup>C interface is transmitting data (I2C\_STS1.TXDATE=1, new data have not transmitting to register), and I2C\_DAT register still empty, it will occurs an underrun error. In this situation, the previous byte in the I2C\_DAT register is

transmitting repeatedly. And user should make sure that in the event of an underrun error, the receiver discard repeatedly byte, and transmitter should update the I2C\_DAT register at the specified time according to the I<sup>2</sup>C bus standard.

When transmitting the first byte, I2C\_DAT register must be written after I2C\_STS1.ADDRF bit is cleared and before the first SCL rising edge. If cannot make sure do that, the first byte should be discard by receiver.

### 17.3.4 DMA Application

DMA can generate a requests when transfer data register empty or full. DMA can write data to I<sup>2</sup>C or read data from I<sup>2</sup>C reduce the CPU overload.

Before transfer current byte at the end DMA requests must be responed. When the data transfer set by the corresponding DMA channel is completed, the DMA controller sends an end of transfer (EOT) signal to the I<sup>2</sup>C interface, and trigger an interrupt when interrupts are enabled..

In the master transmit mode, in the EOT interrupt handler DMA request need to be disbale, and set stop condition after waiting for I2C\_STS1.BSF event.

In the master receive mode, the data of received is great than or equal to 2, DMA will send a hardware signal EOT\_1 in DMA transmission(byte number-1). If I2C\_CTRL2.DMALAST bit is set, when hardware have send the EOT\_1 next byte it will transmit a NACK automatically. The user can set a stop condition in the interrupt handler after the DMA transfer is completed if interrupt is enabled.

#### 17.3.4.1 Transmit process

DMA mode is enabled by setting the I2C\_CTRL2.DMAEN bit. As long as I2C\_STS1.TXDATE bit is set, the data will be transmitted to I2C\_DAT from preset memory area by the DMA. DMA assigns a channle for I<sup>2</sup>C transmission, the following step must be operated (x is the channel number):

1. In the DMA\_PADDRx register set the I2C\_DAT register address. Data will be transmitted to this address in every I2C\_STS1.TXDATE event.
2. In the DMA\_MADDRx register set the memory address. Data will be transmitted to I2C\_DAT address in every I2C\_STS1.TXDATE event.
3. In the DMA\_TXNUMx register set the number of need to be transferred. In every I2C\_STS1.TXDATE event this number-1 until 0.
4. In the DMA\_CHCFGx register set PRIOLVL[1:0] bit to configure the priority of channel.
5. In the DMA\_CHCFGx register set DIR bit to configure when occurs an interrupt whether transmit a half data or all completed.
6. In the DMA\_CHCFGx register set CHEN bit to enable transfer channel.
7. When DMA transfer data is done, DMA need send a EOT/EOT\_1 signal to I<sup>2</sup>C indicate this transfer is done. If interrupt is enable, DMA occurs a interrrupt.

*Note: if DMA is used for transmission, do not set I2C\_CTRL2.BUFINTEN bit.*

#### 17.3.4.2 Receive process

DMA mode is enabled by setting the I2C\_CTRL2.DMAEN bit. When data byte is received, DMA will transmit I<sup>2</sup>C data

to memory area, set DMA channel for I<sup>2</sup>C reception. The following steps must be operate:

1. In DMA\_PADDRx register set the address of the I2C\_DAT register. In every I2C\_STS1.RXDATEN event, data will be transmitted from address to memory area.
2. In DMA\_MADDRx register set the memory area address. In every I2C\_STS1.RXDATEN event, data will be transmitted from I2C\_DAT register to memory area.
3. In DMA\_TXNUMx register set the number of need to be transferred. In every I2C\_STS1.RXDATEN event the number-1 until 0.
4. In DMA\_CHCFGx register set PRIOLVL[0:1] to configure the priority of channel.
5. In DMA\_CHCFGx register clear DIR to configure when occurs a interrupt request whether received half data or all data is received.
6. In the DMA\_CHCFGx register set CHEN bit to activate the channle.
7. When DMA transfer data is done, DMA need to send EOT/EOT\_1 signal to I<sup>2</sup>C indicate this transfer is done, if interrupt is enbale, DMA occurs a interrupt.

*Note: If DMA is used for receiving, do not set I2C\_CTRL2.BUFINTEN bit.*

### 17.3.5 Packet Error Check(PEC)

Setting the I2C\_CTRL1.PECEN bit to 1 enables the PEC function. PEC uses CRC-8 algorithm to calculate all information bytes including address and read/write bits. It can improve the reliability of communication. The CRC-8 polynomial uses by the PEC calculator is  $C(x) = x^8 + x^2 + x + 1$ .

In transmit mode, software sets I2C\_CTRL1.PEC transfer bit at the last I2C\_STS1.TXDATE event, and then PEC will be transmitted after the last byte. In receive mode, software sets I2C\_CTRL1.PEC transfer bit after the last I2C\_STS1.RXDATNE event, and then receives the PEC byte and compares the received PEC byte with the internally calculated PEC value. If it is not equal to the internally calculated PEC value, the receiver needs to transmit a NACK. If it is host receiver mode, NACK will be sent after PEC regardless of the calculated result. It should pay attention that I2C\_CTRL1.PEC bit has to be set before receiving.

If both DMA and PEC calculator are activated, I<sup>2</sup>C will automatically send or check the PEC value.

In transmit mode, when I<sup>2</sup>C interface receives EOT signal from DMA controller, it will automatically send PEC following the last byte. In receive mode, when I<sup>2</sup>C interface receives an EOT\_1 signal from DMA, it will automatically consider the next byte as PEC and compare it with the internally calculated PEC. It will happen a DMA request after receiving PEC.

In order to allow intermediate PEC transmit, I2C\_CTRL2.DMALAST bit is used to determine whether it is the last DMA transfer. And if it is the last DMA request of the master receiver, NACK will be sent automatically after receiving the last byte.

When arbitration is lost, PEC calculation is invalid.

**17.3.6 SMBus**

**17.3.6.1 Introduction**

The System Management Bus(SMBus or SMB) is a simple single-ended two-wire bus structure. Using SMBus can communicate with other device or other parts of the system, it is able to communicate with multiple devices without other independent control wire. SMBus is a derivative form of the I<sup>2</sup>C bus, providing a control bus for system and power management tasks. If you want browse more information, please refer to the SMBus specification v2.0(<http://smbus.org/specs/>).

SMBus have three types of device standard:

- Master: device transmit command, generate clocks and stop transmissions;
- Slave: device receive,respond to commands;
- Host: a system have only one host, which provides the main interface with the system CPU. The host have function of master and slave, it supports SMBus alert protocol.

Similarities between SMBus and I<sup>2</sup>C:

- Both bus protocols contain of 2 wires (a clock wire SCL and a data wire SDA), with an optional SMBus alert wire.
- The data format is similar. SMBus data format is similar to 7-bit address format of I<sup>2</sup>C(refer to Figure 17-2).
- Both are master-slave communication modes, and the master device provides the clock.
- Both support multi master

Differences between SMBus and I<sup>2</sup>C:

**Table 17-1 Comparison Between SMBus and I<sup>2</sup>C**

| SMBus  | I <sup>2</sup> C                                      |
|--|---|
| Maximum transmission speed 100kHz                            | Maximum transmission speed 1MHz                       |
| Minimum transmission speed 10kHz                             | No minimum transmission speed                         |
| Low clock timeout 35ms                                       | No clock timeout                                      |
| Fixed logic level  | V <sub>DD</sub> determined logic level                |
| Different address types (reserved, dynamic, etc.)            | 7-bit, 10-bit, and broadcast call slave address types |
| Different bus protocols (quick command, call handling, etc.) | No bus protocol                                       |

**17.3.6.2 SMBus usage**

SMBus uses the system management bus to meet lightweight communication requirements. In general, SMBus is commonly used on the computer motherboard. It is mainly used to transmit ON/OFF instructions for power unit and provides a control bus for system and power management-related tasks.

**17.3.6.3 Device identification**

In SMBus, when any device acts as a slave device, it has an address called the slave address.

In order to distribute address for each devices, it must have a unique device identifier(UDID) to distinguish devices.

#### 17.3.6.4 Bus protocol

SMBus specification includes eight bus protocols. To learn more about SMBus and address types, please refer to the SMBus specification v2.0(<http://smbus.org/specs/>). Users can decide which protocols to use.

*Note: SMBus does not support Quick command protocol.*

Each message exchange on SMBus follows the predefined format specified in the SMBus protocol. SMBus is a subset of the data transfer format of I<sup>2</sup>C specification. As long as an I<sup>2</sup>C device can be accessed through one of the SMBus protocols, it is considered compliant with the SMBus specification.

#### 17.3.6.5 Address resolution protocol

The SMBus resolves address conflicts by dynamically assigning a new unique address to each slave device. This is the address resolution protocol(ARP) . ARP has the following features:

Any SMBus master device can traverse the bus.

Using the SMBus physical layer arbitration mechanism to assign addresses. When a device remains powered, the assigned address remains unchanged, and the protocol also allows the address to be retained after power-off.

After address allocation, there is no extra SMBus packaging cost(the cost time that access distribute address device and access fixed address device is same).

#### 17.3.6.6 Timeout error

A kind of feature related to timeout on SMBus: if it has taken too long time during the communication, it automatically resets the device. This is the reason why SMBus has a minimum transmission rate limitation, the reason is preventing the bus from locking up for a long time after the timeout occurs. I<sup>2</sup>C bus is essentially a "DC" bus, that is to say, if the slave is executing some subroutines and cannot respond in time while the master is accessing the slave, it can hold the clock. That can remind the host that the slave is busy but does not want to give up the current communication. This session can continue after the current task of the slave is over. I<sup>2</sup>C doesn't have a maximum limitation for the delay, but it is limited to 35ms in the SMBus system. According to the SMBus protocol, if a session takes too long, it means something is wrong with the bus, and all devices should be reset to eliminate this state. Like this, the slave device is not allowed to pull the clock down for too long. I2C\_STS1.TIMOUT bit indicates the status of this feature.

#### 17.3.6.7 SMBus alter mode

SMBus offers a optional interrupt signal SMBALERT(like SCL and SDA,is a wire-AND signal) that devices uses to extend their control capabilities at expense of a pin. SMBus broadcast call address often combine with SMBALERT. There are 2 bytes messages about SMBus.

A device which only has slave function can set I2C\_CTRL1.SMBALERT bit to indicate it want to communicate with host. The host handles the interrupt and accesses all SMBALERT devices through the ARA (Alert Response Address, address value 0001100x). Only those devices that pull SMBALERT low can respond to ARA. This state is identified by the I2C\_STS1.SMBALERT. The 7-bit device address provided from the transmitting device is placed on the 7 most significant bits of the byte, the eighth bit can be either '0' or '1'.

When more than one device's SMBALERT is low, the highest priority(the smaller the address, the higher the priority) can win bus communication through the standard arbitration during address transmission. If confirming the slave address, device's SMBALERT is no longer pulled low. If message transmitted completely, device's SMBALERT still is low, it

means host will read ARA again. The host can periodically access the ARA when the SMBALERT signal is not used.

### 17.3.6.8 SMBus communication process

The communication process on SMBus is similar to that on I2C. To use the SMBus mode, you need to configure SMBus specific registers in the program, respond and process SMBus specific flag, and implement the upper-layer protocols described in the SMBus manual.

1. At first, set I2C\_CTRL1.SMBMODE bit, and configure I2C\_CTRL1.SMBTYPE bit and I2C\_CTRL1.ARPEN bit according to the application requirements. If I2C\_CTRL1.ARPEN=1 and I2C\_CTRL1.SMBTYPE=0, use the default address of the SMB device. If I2C\_CTRL1.ARPEN=1 and I2C\_CTRL1.SMBTYPE=1, use the SMB master header field.
2. In order to support ARP (I2C\_CTRL1.ARPEN=1), in SMBus host mode (I2C\_CTRL1.SMBTYPE=1), software needs to respond to the I2C\_STS2.SMBHADDR bit (in SMBus slave mode, respond to I2C\_STS2.SMBDADDR bit) and implements the functions according to the ARP protocol.
3. To support the SMBus warning mode, software should respond to the I2C\_STS1.SMBALERT bit and implements the corresponding functions.

## 17.4 Debug Mode

When the microcontroller enters the debug mode (Cortex<sup>®</sup>-M0 core is in the stop state), based on the configuration of DBG\_CTRL.I2CxTIMOUT bit in the PWR module, the SMBus timeout control can either continue normal operation or be halted. Refer to Section 3.3.2 for details.

## 17.5 Interrupt Request

All I<sup>2</sup>C interrupt requests are listed in the following table.

**Table 17-2 I<sup>2</sup>C Interrupt Request**

| Interrupt Function                | Interrupt Event                                  | Event Flag | Set Control Bit       |
|-----------------------------------|--|------------|-----------------------|
| I <sup>2</sup> C global interrupt | Start bit sent (master)                          | STARTBF    | EVTINTEN              |
|                                   | Address sent (master) or address matched (slave) | ADDRF      |                       |
|                                   | 10-bit header sent (master)                      | ADDR10F    |                       |
|                                   | Received stop (slave)                            | STOPF      |                       |
|                                   | Data byte transfer completed.                    | BSF        |                       |
|                                   | Receive buffer is not empty.                     | RXDATNE    | EVTINTEN and BUFINTEN |
|                                   | Transmit buffer is empty.                        | TXDATE     |                       |
|                                   | Bus error  | BUSERR     | ERRINTEN              |
|                                   | Lost arbitration (master)                        | ARLOST     |                       |
|                                   | Acknowledge fail                                 | ACKFAIL    |                       |
|                                   | Overrun/underrun                                 | OVERRUN    |                       |
|                                   | PEC error  | PECERR     |                       |
|                                   | Timeout /Tlow error                              | TIMOUT     |                       |
|                                   | SMBus Alert                                      | SMBALERT   |                       |



Notes:

- (1). *STARTBF, ADDR, ADDR10F, STOPF, BSF, RXDATNE and TXDATE* are merged into a interrupt channel through logical OR.
- (2) *BUSERR, ARLOST, ACKFAIL, OVERRUN, PECERR, TIMEOUT and SMBALERT* are merged into a interrupt channel through logical OR.
- (3) *Event interrupts and error interrupts* are logically ORed into the global interrupt channel.

## 17.6 I<sup>2</sup>C Registers

These peripheral registers can be operated by half word (16 bits) or word (32 bits)

### 17.6.1 I<sup>2</sup>C Register Overview

Table 17-3 I<sup>2</sup>C Register Overview

| Offset | Register    | 31       | 30 | 29 | 28 | 27 | 26 | 25 | 24 | 23 | 22 | 21 | 20 | 19 | 18 | 17 | 16 | 15          | 14       | 13       | 12            | 11      | 10          | 9        | 8         | 7         | 6            | 5        | 4     | 3       | 2        | 1       | 0       |   |   |   |   |   |   |
|--------|-------------|----------|----|----|----|----|----|----|----|----|----|----|----|----|----|----|----|-------------|----------|----------|---------------|---------|-------------|----------|-----------|-----------|--------------|----------|-------|---------|----------|---------|---------|---|---|---|---|---|---|
| 000h   | I2C_CTRL1   | Reserved |    |    |    |    |    |    |    |    |    |    |    |    |    |    |    | SWRESET     | Reserved | SMBALERT | PEC           | ACKPOS  | ACKEN       | STOPGEN  | STARTGEN  | NOEXTEND  | GCEN         | PECEN    | ARPEN | SMBTYPE | Reserved | SMBMODE | EN      | 0 |   |   |   |   |   |
|        | Reset Value |          |    |    |    |    |    |    |    |    |    |    |    |    |    |    |    | 0           |          | 0        | 0             | 0       | 0           | 0        | 0         | 0         | 0            | 0        | 0     | 0       | 0        | 0       | 0       | 0 | 0 | 0 | 0 | 0 |   |
| 004h   | I2C_CTRL2   | Reserved |    |    |    |    |    |    |    |    |    |    |    |    |    |    |    |             |          |          | DMALAST       | DMAEN   | BUFINTEN    | EVTINTEN | ERRINTEN  | Reserved  | CLKFREQ[5:0] |          |       |         |          |         |         |   |   |   |   |   |   |
|        | Reset Value |          |    |    |    |    |    |    |    |    |    |    |    |    |    |    |    |             |          |          | 0             | 0       | 0           | 0        | 0         |           |              |          | 0     | 0       | 0        | 0       | 0       | 0 | 0 | 0 | 0 | 0 | 0 |
| 008h   | I2C_OADDR1  | Reserved |    |    |    |    |    |    |    |    |    |    |    |    |    |    |    | ADDRMODE    | Reserved | Reserved |               |         |             |          | ADDR[9:8] | ADDR[7:1] |              |          |       |         | ADDR0    |         |         |   |   |   |   |   |   |
|        | Reset Value |          |    |    |    |    |    |    |    |    |    |    |    |    |    |    |    | 0           |          |          |               |         |             |          | 0         | 0         | 0            | 0        | 0     | 0       | 0        | 0       | 0       | 0 | 0 | 0 | 0 | 0 | 0 |
| 00Ch   | I2C_OADDR2  | Reserved |    |    |    |    |    |    |    |    |    |    |    |    |    |    |    |             |          |          |               |         | ADDR2[7:1]  |          |           |           |              | DUALEN   |       |         |          |         |         |   |   |   |   |   |   |
|        | Reset Value |          |    |    |    |    |    |    |    |    |    |    |    |    |    |    |    |             |          |          |               |         | 0           | 0        | 0         | 0         | 0            | 0        | 0     | 0       | 0        | 0       | 0       | 0 | 0 | 0 |   |   |   |
| 010h   | I2C_DAT     | Reserved |    |    |    |    |    |    |    |    |    |    |    |    |    |    |    |             |          |          |               |         | DATA[7:0]   |          |           |           |              |          |       |         |          |         |         |   |   |   |   |   |   |
|        | Reset Value |          |    |    |    |    |    |    |    |    |    |    |    |    |    |    |    |             |          |          |               |         | 0           | 0        | 0         | 0         | 0            | 0        | 0     | 0       | 0        | 0       | 0       | 0 | 0 |   |   |   |   |
| 014h   | I2C_STS1    | Reserved |    |    |    |    |    |    |    |    |    |    |    |    |    |    |    | SMBALERT    | TIMOUT   | Reserved | PECERR        | OVERRUN | ACKFAIL     | ARLOST   | BUSERR    | TXDATE    | RXDATNE      | Reserved | STOPF | ADDR10F | BSF      | ADDRF   | STARTBF |   |   |   |   |   |   |
|        | Reset Value |          |    |    |    |    |    |    |    |    |    |    |    |    |    |    |    | 0           | 0        |          | 0             | 0       | 0           | 0        | 0         | 0         | 0            | 0        | 0     | 0       | 0        | 0       | 0       | 0 | 0 | 0 |   |   |   |
| 018h   | I2C_STS2    | Reserved |    |    |    |    |    |    |    |    |    |    |    |    |    |    |    | PECVAL[7:0] |          |          |               |         | DUALFLAG    | SMBHADDR | SMBDADDR  | GCALLADDR | Reserved     | TRF      | BUSY  | MISMODE |          |         |         |   |   |   |   |   |   |
|        | Reset Value |          |    |    |    |    |    |    |    |    |    |    |    |    |    |    |    | 0           | 0        | 0        | 0             | 0       | 0           | 0        | 0         | 0         | 0            | 0        | 0     | 0       | 0        | 0       | 0       | 0 | 0 | 0 | 0 |   |   |
| 01Ch   | I2C_CLKCTRL | Reserved |    |    |    |    |    |    |    |    |    |    |    |    |    |    |    | FSMODE      | DUTY     | Reserved | CLKCTRL[11:0] |         |             |          |           |           |              |          |       |         |          |         |         |   |   |   |   |   |   |
|        | Reset Value |          |    |    |    |    |    |    |    |    |    |    |    |    |    |    |    | 0           | 0        |          | 0             | 0       | 0           | 0        | 0         | 0         | 0            | 0        | 0     | 0       | 0        | 0       | 0       | 0 | 0 | 0 | 0 |   |   |
| 020h   | I2C_TMRISE  | Reserved |    |    |    |    |    |    |    |    |    |    |    |    |    |    |    |             |          |          |               |         | TMRISE[5:0] |          |           |           |              |          |       |         |          |         |         |   |   |   |   |   |   |
|        | Reset Value |          |    |    |    |    |    |    |    |    |    |    |    |    |    |    |    |             |          |          |               |         | 0           | 0        | 0         | 0         | 0            | 0        | 0     | 0       | 0        |         |         |   |   |   |   |   |   |

## 17.6.2 I<sup>2</sup>C Control Register 1 (I2C\_CTRL1)

Address offset: 0x00

Reset value: 0x0000

|             |          |              |     |            |       |             |              |              |      |       |       |             |          |             |    |
|-------------|----------|--------------|-----|------------|-------|-------------|--------------|--------------|------|-------|-------|-------------|----------|-------------|----|
| 15          | 14       | 13           | 12  | 11         | 10    | 9           | 8            | 7            | 6    | 5     | 4     | 3           | 2        | 1           | 0  |
| SW<br>RESET | Reserved | SMB<br>ALERT | PEC | ACK<br>POS | ACKEN | STOP<br>GEN | START<br>GEN | NO<br>EXTEND | GCEN | PECEN | ARPEN | SMB<br>TYPE | Reserved | SMB<br>MODE | EN |
| rw          |          | rw           | rw  | rw         | rw    | rw          | rw           | rw           | rw   | rw    | rw    | rw          |          | rw          | rw |

| Bit Field | Name     | Description  |
|-----------|----------|--|
| 15        | SWRESET  | <p>Software reset</p> <p>Make sure the I<sup>2</sup>C bus is idle before resetting this bit.</p> <p>0:I<sup>2</sup>C not reset;<br/>1:I<sup>2</sup>C reset.</p> <p><i>Note: This bit can be used when the I2C_STS2.BUSY bit is set to 1 and no stop condition is detected on the bus.</i></p>  |
| 14        | Reserved | Reserved, the reset value must be maintained   |
| 13        | SMBALERT | <p>SMBus alert</p> <p>It can be set or cleared by software. When I2C_CTRL1.EN=0, it will be cleared by hardware.</p> <p>0: SMBAlert pin go high. The response address header is followed by the NACK signal;<br/>1: SMBAlert pin go low. The response address header is followed by the ACK signal.</p>  |
| 12        | PEC      | <p>Packet error checking</p> <p>It can be set or cleared by software. It will be cleared by hardware when PEC has been transferred, or by start or stop condition, or when I2C_CTRL1.EN=0.</p> <p>0: No PEC transfer<br/>1: PEC transfer.</p> <p><i>Note: When arbitration is lost, the calculation of PEC is invalid.</i></p>   |
| 11        | ACKPOS   | <p>Acknowledge/PEC Position (for data reception)</p> <p>It can be set or cleared by software. Or when I2C_CTRL1.EN=0, it will be cleared by hardware.</p> <p>0: I2C_CTRL1.ACKEN bit determines whether to send an ACK to the byte currently being received; I2C_CTRL1.PEC bit indicates that the byte in the current shift register is PEC.</p> <p>1: I2C_CTRL1.ACKEN bit determines whether to send an ACK to the next received byte; I2C_CTRL1.PEC bit indicates that the next byte received in the shift register is PEC.</p> <p><i>Note:</i></p> <p><i>ACKPOS bit can only be used in 2-byte receiving configuration and must be configured before receiving data.</i></p> <p><i>For the second byte of NACK, the I2C_CTRL1.ACKEN bit must be cleared after the I2C_STS1.ADDRF bit is cleared.</i></p> <p><i>To detect the PEC of the second byte, the I2C_CTRL1.PEC bit must be set after the ACKPOS bit is configured and when the ADDR event is extended.</i></p> |

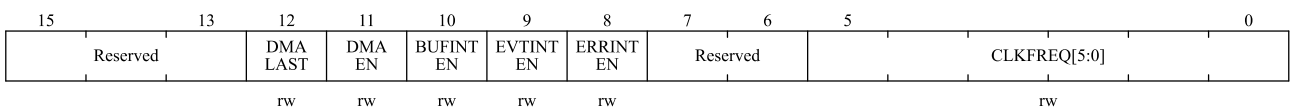
| Bit Field | Name     | Description  |
|-----------|----------|--|
| 10        | ACKEN    | <p>Acknowledge enable</p> <p>It can be set or cleared by software. Or when I2C_CTRL1.EN equals to 0, it will be cleared by hardware.</p> <p>0: No acknowledge send;<br/>1: Send an acknowledge after receiving a byte</p>  |
| 9         | STOPGEN  | <p>Stop generation</p> <p>It can be set or cleared by software. Or it will be cleared by hardware when a stop condition is detected. Or it will be set by hardware when SMBus timeout error is detected.</p> <p>In the master mode:<br/>0: No stop condition generates;<br/>1: Generate a stop condition.</p> <p>In the slave mode:<br/>0: No stop condition generates;<br/>1: Release SCL and SDA lines after the current byte.</p> <p><i>Note: When the STOPGEN, STARTGEN or PEC bit is set, the software should not take any write operation to I2C_CTRL1 until this bit is cleared by hardware. Otherwise, the STOPGEN, STARTGEN or PEC bits may be set twice.</i></p> |
| 8         | STARTGEN | <p>Start generation</p> <p>It can be set or cleared by software. Or it will be cleared by hardware when the start condition is transferred or I2C_CTRL1.EN=0.</p> <p>0: No start condition generates;<br/>1: Generate a start conditions.</p>  |
| 7         | NOEXTEND | <p>Clock extending disable (Slave mode)</p> <p>This bit determines whether to pull SCL low when the data is not ready(I2C_STS1.ADDRF or I2C_STS1.BSF flag is set) in slave mode, and is cleared by software reset</p> <p>0: Enable Clock extending.<br/>1: Disable Clock extending.</p>  |
| 6         | GCEN     | <p>General call enable</p> <p>0: Disable General call. not respond(NACK) to the address 00h;<br/>1: Enable General call. respond(ACK) the address 00h.</p>   |
| 5         | PECEN    | <p>PEC enable</p> <p>0: Disable PEC module;<br/>1: Enable PEC module.</p>  |
| 4         | ARPEN    | <p>ARP enable</p> <p>0: Disable ARP;<br/>1: Enable ARP.</p> <p>If I2C_CTRL1.SMBTYPE=0, the default address of SMBus device is used.<br/>If I2C_CTRL1.SMBTYPE=1, the host address of SMBus is used.</p>   |
| 3         | SMBTYPE  | <p>SMBus type</p> <p>0: Device</p>   |

| Bit Field | Name     | Description  |
|-----------|----------|--|
|           |          | 1: Host  |
| 2         | Reserved | Reserved, the reset value must be maintained.  |
| 1         | SMBMODE  | SMBus mode<br>0: I <sup>2</sup> C mode;<br>1: SMBus mode.  |
| 0         | EN       | I <sup>2</sup> C Peripheral enable<br>0: Disable I <sup>2</sup> C module;<br>1: Enable I <sup>2</sup> C module<br><i>Note: If this bit is cleared when communication is in progress, the I<sup>2</sup>C module is disabled and returns to the idle state after the current communication ends, all bits will be cleared. In master mode, this bit must never be cleared until the communication has ended.</i> |

### 17.6.3 I<sup>2</sup>C Control Register 2 (I2C\_CTRL2)

Address offset: 0x04

Reset value: 0x0000



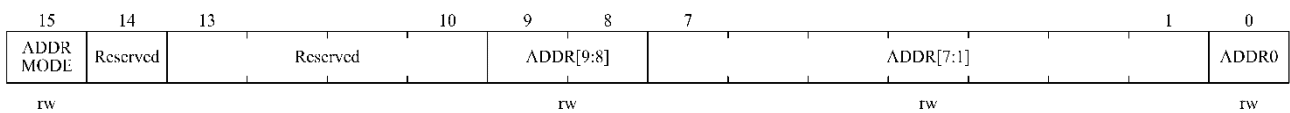
| Bit Field | Name     | Description   |
|-----------|----------|---|
| 15:13     | Reserved | Reserved, the reset value must be maintained.   |
| 12        | DMALAST  | DMA last transfer<br>0: Next DMA EOT is not the last transfer<br>1: Next DMA EOT is the last transfer<br><i>Note: This bit is used in the master receiving mode, so that a NACK can be generated when data is received for the last time.</i> |
| 11        | DMAEN    | DMA requests enable<br>0: Disable DMA<br>1: Enable DMA  |
| 10        | BUFINTEN | Buffer interrupt enable<br>0: When I2C_STS1.TXDATE=1 or I2C_STS1.RXDATNE=1, any interrupt is not generated.<br>1: If I2C_CTRL2.EVTINTEN= 1, When I2C_STS1.TXDATE=1 or I2C_STS1.RXDATNE= 1, interrupt will be generated.                       |
| 9         | EVTINTEN | Event interrupt enable<br>0: Disable event interrupt;<br>1: Enable event interrupt<br>This interrupt is generated when:<br>I2C_STS1.STARTBF = 1 (Master)<br>I2C_STS1.ADDRF = 1 (Master/Slave)<br>I2C_STS1.ADD10F = 1 (Master)                 |

| Bit Field | Name         | Description  |
|-----------|--------------|--|
|           |              | I2C_STS1.STOPF = 1 (Slave)<br>I2C_STS1.BSF = 1 with no I2C_STS1.TXDATE or I2C_STS1.RXDATNE event<br>I2C_STS1.TXDATE = 1 if I2C_CTRL2.BUFINTEN = 1<br>I2C_STS1.RXDATNE = 1 if I2C_CTRL2.BUFINTEN = 1  |
| 8         | ERRINTEN     | Error interrupt enable<br>0: Disable error interrupt;<br>1: Enable error interrupt.<br>This interrupt is generated when:<br>I2C_STS1.BUSERR = 1;<br>I2C_STS1.ARLOST = 1;<br>I2C_STS1.ACKFAIL = 1;<br>I2C_STS1.OVERRUN = 1;<br>I2C_STS1.PECERR = 1;<br>I2C_STS1.TIMOUT = 1;<br>I2C_STS1.SMBALERT = 1. |
| 7:6       | Reserved     | Reserved, the reset value must be maintained.  |
| 5:0       | CLKFREQ[5:0] | I <sup>2</sup> C Peripheral clock frequency<br>CLKFREQ[5:0] should be the APB1 clock frequency to generate the correct timing.<br>000000: Disable<br>000001: Disable<br>000010: 2MHz<br>000011: 3MHz<br>...<br>110000: 48MHz<br>110001~111111: Disable.  |

### 17.6.4 I<sup>2</sup>C Own Address Register 1 (I2C\_OADDR1)

Address offset: 0x08

Reset value: 0x0000



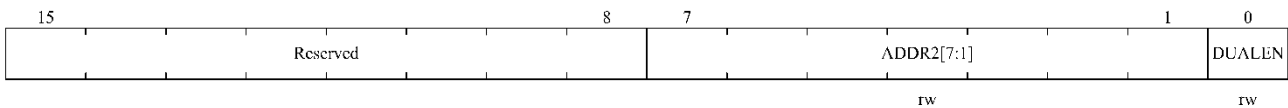
| Bit Field | Name     | Description   |
|-----------|----------|---|
| 15        | ADDRMODE | Addressing mode (slave mode)<br>0: 7-bit slave address<br>1: 10-bit slave address |
| 14        | Reserved | Must always be kept as '1' by the software.                                       |
| 13:10     | Reserved | Reserved, the reset value must be maintained.                                     |

| Bit Field | Name      | Description   |
|-----------|-----------|---|
| 9:8       | ADDR[9:8] | Interface address<br>9~8 bits of the address.<br><i>Note: don't care these bits in 7-bit address mode</i> |
| 7:1       | ADDR[7:1] | Interface address<br>7~1 bits of the address.   |
| 0         | ADDR0     | Interface address<br>0 bit of the address.<br><i>Note: don't care these bits in 7-bit address mode</i>    |

### 17.6.5 I<sup>2</sup>C Own Address Register 2 (I2C\_OADDR2)

Address offset: 0x0C

Reset value: 0x0000

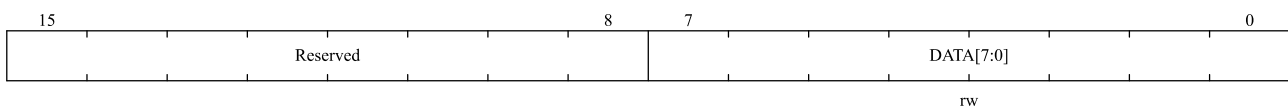


| Bit Field | Name       | Description  |
|-----------|------------|--|
| 15:8      | Reserved   | Reserved, the reset value must be maintained.  |
| 7:1       | ADDR2[7:1] | Interface address<br>7~1 bits of address in dual address mode.   |
| 0         | DUALEN     | Dual addressing mode enable<br>0: Disable dual address mode, only OADDR1 is recognized;<br>1: Enable dual address mode, both OADDR1 and OADDR2 are recognized.<br><i>Note: Valid only for 7-bit address mode</i> |

### 17.6.6 I<sup>2</sup>C Data Register (I2C\_DAT)

Address offset: 0x10

Reset value: 0x0000



| Bit Field | Name      | Description  |
|-----------|-----------|--|
| 15:8      | Reserved  | Reserved, the reset value must be maintained.  |
| 7:0       | DATA[7:0] | 8-bit data register<br>Transmit or receive data buffer.<br><i>Note: In the slave mode, the address will not be copied into the data register;</i><br><i>Note: if I2C_STS1.TXDATE = 0, data can still be written into the data register;</i><br><i>Note: If the ARLOST event occurs when processing the ACK pulse, the received byte will not be copied into the data register, so it cannot be read.</i> |

### 17.6.7 I<sup>2</sup>C Status Register 1 (I2C\_STS1)

Address offset: 0x14

Reset value: 0x0000

|              |            |          |            |             |             |            |            |        |             |          |       |         |     |       |             |
|--------------|------------|----------|------------|-------------|-------------|------------|------------|--------|-------------|----------|-------|---------|-----|-------|-------------|
| 15           | 14         | 13       | 12         | 11          | 10          | 9          | 8          | 7      | 6           | 5        | 4     | 3       | 2   | 1     | 0           |
| SMB<br>ALERT | TIM<br>OUT | Reserved | PEC<br>ERR | OVER<br>RUN | ACK<br>FAIL | AR<br>LOST | BUS<br>ERR | TXDATE | RXDAT<br>NE | Reserved | STOPF | ADDR10F | BSF | ADDRF | START<br>BF |
| rc_w0        | rc_w0      |          | rc_w0      | rc_w0       | rc_w0       | rc_w0      | rc_w0      | r      | r           |          | r     | r       | r   | r     | r           |

| Bit Field | Name     | Description   |
|-----------|----------|---|
| 15        | SMBALERT | SMBus alert<br>Writing '0' to this bit by software can clear it, or it is cleared by hardware when I2C_CTRL1.EN=0.<br>0: No SMBus alert(host mode) or no SMB alert response address header sequence(slave mode);<br>1: SMBus alert event is generated on the pin(host mode) or receive SMBAlert response address(slave mode)  |
| 14        | TIMOUT   | Timeout or Tlow error<br>Writing '0' to this bit by software can clear it, or it is cleared by hardware when I2C_CTRL1.EN=0.<br>0: No Timeout error;<br>1: A timeout error occurred<br>Error in the following cases: <ul style="list-style-type: none"> <li>■ SCL has kept low for 25ms (Timeout).</li> <li>■ Master cumulative clock low extend time more than 10 ms (Tlow:mext).</li> <li>■ Slave cumulative clock low extend time more than 25 ms (Tlow:sext).</li> </ul> Timeout in slave mode: slave device resets the communication and hardware frees the bus.<br>Timeout in master mode: hardware transmits the stop condition. |
| 13        | Reserved | Reserved, the reset value must be maintained.   |
| 12        | PECERR   | PEC Error in reception<br>Writing '0' to this bit by software can clear it, or it is cleared by hardware when I2C_CTRL1.EN=0.<br>0: No PEC error<br>1: PEC error: receiver will returns NACK Whether the I2C_CTRL1.ACKEN bit is enabled   |
| 11        | OVERRUN  | Overrun/Underrun<br>Writing '0' to this bit by software can clear it, or it is cleared by hardware when I2C_CTRL1.EN=0.<br>0: No Overrun/Underrun<br>1: Overrun/Underrun<br>Set by hardware in slave mode when I2C_CTRL1.NOEXTEND=1, and when receiving a new byte in receiving mode, if the data within DAT register has not been read yet,  |

| Bit Field | Name    | Description  |
|-----------|---------|--|
|           |         | over-run occurs, the new received byte will be lost. When transferring a new byte in transfer mode, but there is not new data that has not been written in DAT register, under-run occurs which leads that the same byte will be transmitted twice.  |
| 10        | ACKFAIL | Acknowledge failure<br>Writing '0' to this bit by software can clear it, or it is cleared by hardware when I2C_CTRL1.EN=0.<br>0: No acknowledge failed;<br>1: Acknowledge failed.  |
| 9         | ARLOST  | Arbitration lost (master mode)<br>Writing '0' to this bit by software can clear it, or it is cleared by hardware when I2C_CTRL1.EN=0.<br>0: No arbitration lost;<br>1: Arbitration lost.<br><br>When the interface loses control of the bus to another host, the hardware will set this bit to '1', and the I <sup>2</sup> C interface will automatically switch back to slave mode (I2C_STS2.MSMODE=0).<br><i>Note: In SMBUS mode, the arbitration of data in slave mode only occurs in the data stage or the acknowledge transfer interval (excluding the address acknowledge).</i>  |
| 8         | BUSERR  | Bus error<br>Writing '0' to this bit by software can clear it, or it is cleared by hardware when I2C_CTRL1.EN=0.<br>0: No start or stop condition error<br>1: Start or stop condition error  |
| 7         | TXDATE  | Data register empty (transmitters)<br>Writing data to DAT register by software can clear this bit; Or after a start or stop condition occurs, or automatically cleared by hardware when I2C_CTRL1.EN=0.<br>0: Data register is not empty;<br>1: Data register is empty.<br><br>When transmitting data, this bit is set to '1' when the data register is empty, and it is not set at the address transmitting stage.<br><br>If a NACK is received, or the next byte to be sent is PEC(I2C_CTRL1.PEC=1), this bit will not be set.<br><i>Note: After the first data to be sent is written, or data is written when BSF is set, the TXDATE bit cannot be cleared, because the data register is still empty.</i> |
| 6         | RXDATNE | Data register not empty (receivers)<br>This bit is cleared by software reading and writing to the data register, or cleared by hardware when I2C_CTRL1.EN=0.<br>0: Data register is empty;<br>1: Data register is not empty.<br><br>During receiving data, this bit is set to '1' when the data register is not empty, and it is not set at the address receiving stage.   |



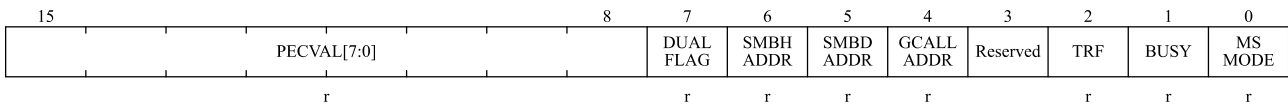
| Bit Field | Name     | Description   |
|-----------|----------|---|
|           |          | <p>RXDATNE is not set when the ARLOST event occurs.</p> <p><i>Note: When BSF is set, the RXDATNE bit cannot be cleared when reading data, because the data register is still full.</i></p>  |
| 5         | Reserved | Reserved, the reset value must be maintained.   |
| 4         | STOPF    | <p>Stop detection (slave mode)</p> <p>After the software reads the STS1 register, the operation of writing to the CTRL1 register will clear this bit, or when I2C_CTRL1.EN=0, the hardware will clear this bit.</p> <p>0: No stop condition is detected;<br/>1: Stop condition is detected.</p> <p>After a ACK, the hardware sets this bit to '1' when the slave device detects a stop condition on the bus.</p> <p><i>Note: I2C_STS1.STOPF bit is not set after receiving NACK.</i></p>  |
| 3         | ADDR10F  | <p>10-bit header sent (Master mode)</p> <p>After the software reads the STS1 register, the operation of writing to the CTRL1 register will clear this bit, or when I2C_CTRL1.EN=0, the hardware will clear this bit.</p> <p>0: No ADDR10F event;<br/>1: Received has sent the first address byte.</p> <p>In 10-bit address mode, when the master device has sent the first byte, the hardware sets this bit to '1'.</p> <p><i>Note: After receiving a NACK, the I2C_STS1.ADDR10F bit is not set.</i></p>  |
| 2         | BSF      | <p>Byte transfer finished</p> <p>After the software reads the STS1 register, reading or writing the data register will clear this bit; Or after transmitting a start or stop condition in transmitting mode, or when I2C_CTRL1.EN=0, this bit is cleared by hardware.</p> <p>0: Byte transfer does not finish.<br/>1: Byte transfer finished.</p> <p>When I2C_CTRL1.NOEXTEND =0, the hardware sets this bit to '1' in the following cases:</p> <p>In receiving mode, when a new byte (including ACK pulse) is received and the data register has not been read (I2C_STS1.RXDATNE=1). In transmitting mode, when a new data is to be transmitted and the data register has not been written with the new data (I2C_STS1.TXDATE=1).</p> <p><i>Note: After receiving a NACK, the BSF bit will not be set.</i></p> <p><i>If the next byte to be transferred is PEC (I2C_STS2.TRF is '1' and I2C_CTRL1.PEC is '1'), the BSF bit will not be set.</i></p> |
| 1         | ADDRF    | <p>Address sent (master mode) / matched (slave mode)</p> <p>After the STS1 register is read by software, reading the STS2 register will clear this bit, or when I2C_CTRL1.EN=0, it will be cleared by hardware.</p> <p>0: Address mismatch or no address received(slave mode) or address transmitting did not end(master mode);<br/>1: Received addresses matched(slave mode) or address transmitting ends(master mode)</p>   |

| Bit Field | Name    | Description   |
|-----------|---------|---|
|           |         | <p>In master mode:</p> <p>In 7-bit address mode, this bit is set to '1' after receiving the ACK of the address. In 10-bit address mode, this bit is set to '1' after receiving the ACK of the second byte of the address.</p> <p>In slave mode:</p> <p>Hardware sets this bit to '1' (when the corresponding setting is enabled) when the received slave address matches the content in the OADDR register, or a general call or SMBus device default address or SMBus host or SMBus alter is recognized.</p> <p><i>Note: After receiving NACK, the I2C_STS1.ADDRF bit will not be set.</i></p> |
| 0         | STARTBF | <p>Start bit (Master mode)</p> <p>After the STS1 register is read by software, writing to the data register will clear this bit, or when I2C_CTRL1.EN=0, the hardware will clear this bit.</p> <p>0: Start condition was not sent;<br/>1: Start condition has been sent.</p> <p>This bit is set to '1' when the start condition is sent.</p>  |

### 17.6.8 I<sup>2</sup>C Status Register 2 (I2C\_STS2)

Address offset: 0x18

Reset value: 0x0000



| Bit Field | Name        | Description   |
|-----------|-------------|---|
| 15:8      | PECVAL[7:0] | <p>Packet error checking register</p> <p>Stores the internal PEC value When I2C_CTRL1.PECEN =1.</p>   |
| 7         | DUALFLAG    | <p>Dual flag(Slave mode)</p> <p>Hardware clears this bit when a stop condition or a repeated start condition is generated, or when I2C_CTRL1.EN=0.</p> <p>0: Received address matches the content in OADDR1;<br/>1: Received address matches the content in OADDR2.</p>                                   |
| 6         | SMBHADDR    | <p>SMBus host header (Slave mode)</p> <p>Hardware clears this bit when a stop condition or a repeated start condition is generated, or when I2C_CTRL1.EN=0.</p> <p>0: SMBus host address was not received;<br/>1: when I2C_CTRL1.SMBTYPE=1 and I2C_CTRL1.ARPEN=1, the SMBus host address is received.</p> |
| 5         | SMBDADDR    | <p>SMBus device default address (Slave mode)</p> <p>Hardware clears this bit when a stop condition or a repeated start condition is generated, or when I2C_CTRL1.EN=0.</p> <p>0: The default address of SMBus device has not been received;</p>   |

| Bit Field | Name      | Description  |
|-----------|-----------|--|
|           |           | 1: when I2C_CTRL1.ARPEN=1, the default address of SMBus device is received.  |
| 4         | GCALLADDR | General call address(Slave mode)<br>Hardware clears this bit when a stop condition or a repeated start condition is generated, or when I2C_CTRL1.EN=0.<br>0: No general call address was received;<br>1: when I2C_CTRL1.GCEN=1, general call address was received.   |
| 3         | Reserved  | Reserved, the reset value must be maintained.  |
| 2         | TRF       | Transmitter/receiver<br>After detecting the stop condition (I2C_STS1.STOPF=1), repeated start condition or bus arbitration loss (I2C_STS1.ARLOST=1), or when I2C_CTRL1.EN=0, the hardware clears it.<br>0: Data receiving mode<br>1: Data transmission mode;<br>At the end of the whole address transmission stage, this bit is set according to the R/W bit of the address byte.                              |
| 1         | BUSY      | Bus busy<br>Hardware clears this bit when a stop condition is detected.<br>0: No data communication on the bus;<br>1: Data communication on the bus.<br>When detecting that SDA or SCL is low level, the hardware sets this bit to '1';<br><i>Note: This bit indicates the bus communication currently in progress, and this information is still updated when the interface is disabled (I2C_CTRL1.EN=0).</i> |
| 0         | MSMODE    | Master/slave mode<br>Hardware clears this bit when a stop condition is detected on the bus, arbitration is lost (I2C_STS1.ARLOST=1), or when I2C_CTRL1.EN=0.<br>0: In slave mode;<br>1: In master mode.<br>When the interface is in the master mode (I2C_STS1.STARTBF=1), the hardware sets this bit;  |

### 17.6.9 I<sup>2</sup>C Clock Control Register (I2C\_CLKCTRL)

Address offset: 0x1c

Reset value: 0x0000

Notes:

- (1).  $F_{PCLK1}$  is required to be an integer multiple of 10 MHz, so that a fast clock of 400KHz can be generated correctly.
- (2). The CLKCTRL register can only be set when I<sup>2</sup>C is turned off (I2C\_CTRL1.EN=0)



| Bit Field | Name          | Description   |
|-----------|---------------|---|
| 15:14     | DUTY          | SCL duty cycle<br>00: Tlow/Thigh = 1;<br>01: Tlow/Thigh = 1;<br>10: Tlow/Thigh = 2;<br>11: Tlow/Thigh = 16/9;<br><i>Note: 00 or 01 configuration is recommended for SCL 100K or 1M.<br/>                     10 or 11 configuration recommended for SCL 400K.</i>   |
| 13:12     | Reserved      | Reserved, the reset value must be maintained.   |
| 11:0      | CLKCTRL[11:0] | Clock control register in Fast/Standard mode (Master mode)<br>This division factor is used to set the SCL clock in the master mode.<br>■ If duty cycle = Tlow/Thigh = 1/1:<br>$CLKCTRL = f_{PCLK1}(Hz)/100000/2$<br>$T_{low} = CLKCTRL \times T_{PCLK1}$<br>$T_{high} = CLKCTRL \times T_{PCLK1}$<br>■ If duty cycle = Tlow/Thigh = 2/1:<br>$CLKCTRL = f_{PCLK1}(Hz)/100000/3$<br>$T_{low} = 2 \times CLKCTRL \times T_{PCLK1}$<br>$T_{high} = CLKCTRL \times T_{PCLK1}$<br>■ If duty cycle = Tlow/Thigh = 16/9:<br>$CLKCTRL = f_{PCLK1}(Hz)/100000/25$<br>$T_{low} = 16 \times CLKCTRL \times T_{PCLK1}$<br>$T_{high} = 9 \times CLKCTRL \times T_{PCLK1}$<br>For example, if $f_{PCLK1}(Hz) = 8MHz$ , duty cycle = 1/1, $CLKCTRL = 8000000/100000/2 = 0x28$ .<br><i>Notes:</i><br>(1). The minimum setting value is 0x04 in standard mode and 0x01 in fast mode;<br>(2). $T_{high} = T_{r(SCL)} + T_{w(SCLH)}$ . See the definitions of these parameters in the data sheet for details.<br>(3). $T_{low} = T_{f(SCL)} + T_{w(SCLL)}$ , see the definitions of these parameters in the data sheet for details;<br>(4). These delays have no filters; |

**17.6.10 I<sup>2</sup>C Rise Time Register (I2C\_TMRISE)**

Address offset: 0x20

Reset value: 0x0002



| Bit Field | Name        | Description  |
|-----------|-------------|--|
| 15:6      | Reserved    | Reserved, the reset value must be maintained.  |
| 5:0       | TMRISE[5:0] | <p>Maximum rise time in fast/standard mode (master mode).</p> <p>These bits must be set to the maximum SCL rising time given in the I<sup>2</sup>C bus specification, and incremented step is 1.</p> <p>For example, the maximum allowable SCL rise time in standard mode is 1000ns. if the value in I2C_CTRL2.CLKFREQ [5:0] is equal to 0x08(8MHz) and <math>T_{PCLKI}=125ns</math>, 09h(1000ns/125 ns + 1) must be written in TMRISE[5:0] .</p> <p>If the result is not an integer, write the integer part to TMRISE[5:0] to ensure the <math>t_{HIGH}</math> parameter.</p> <p><i>Note: TMRISE[5:0] can only be set when I<sup>2</sup>C is disabled (EN=0).</i></p> |

## 18 Universal Synchronous Asynchronous Receiver Transmitter

### 18.1 Introduction

USART is a full-duplex universal synchronous/asynchronous serial transceiver module. This interface is a highly flexible serial communication device that can perform full-duplex data exchange with external devices.

The USART has programmable transmit and receive baud rates and can communicate continuously using DMA. It also supports multiprocessor communication, LIN mode, synchronous mode, single-wire half-duplex communication, Smartcard asynchronous protocol, IrDA SIR ENDEC function and hardware flow control function.

### 18.2 Main Features

- Full duplex, asynchronous communication
- NRZ standard format
- Fractional baud rate generator system, baud rate programmable, used for transmitting and receiving up to 3Mbits/s
- Programmable data word length (8 or 9 bits)
- Configurable stop bit, supporting 1 or 2 stop bits
- LIN master's ability to trigger synchronous interrupters and LIN slave's ability to detect interrupters. When USART hardware is configured as LIN, it triggers 13 bit interrupters and detects 10/11 bit interrupters
- Output clock for synchronous transmission
- IrDA SIR encoder decoder, supports 3/16 bit duration in normal mode
- Smartcard simulation function
  - The Smartcard interface supports the asynchronous Smartcard protocol defined in ISO7816-3.
  - 0.5 and 1.5 stop bits for Smartcard
- Single-wire half-duplex communication
- Configurable multi-buffer communication using DMA, receiving/transmitting bytes in SRAM using centralized DMA buffer
- Independent transmitter and receiver enable bits
- Detect flag:
  - Receive buffer is full
  - Transmit buffer is empty
  - Transmission complete
- Parity control:

- Transmit parity bit
- Check the received data
- Four error detection flags:
  - Overflow error
  - Noise error
  - Frame error
  - Parity error
- 10 USART interrupt sources with flags:
  - CTS change
  - LIN break detection
  - Transmit data register empty
  - Transmit complete
  - Received data register is full
  - Bus was detected to be idle
  - Overflow error
  - Frame error
  - Noise error
  - Parity error
- Multi-processor communication, if the address does not match, then enter the silent mode
- Wake up from silent mode (via idle bus detection or address flag detection)
- Mode configuration:

**Table 18-1 Mode Configuration for USARTx and LPUART**

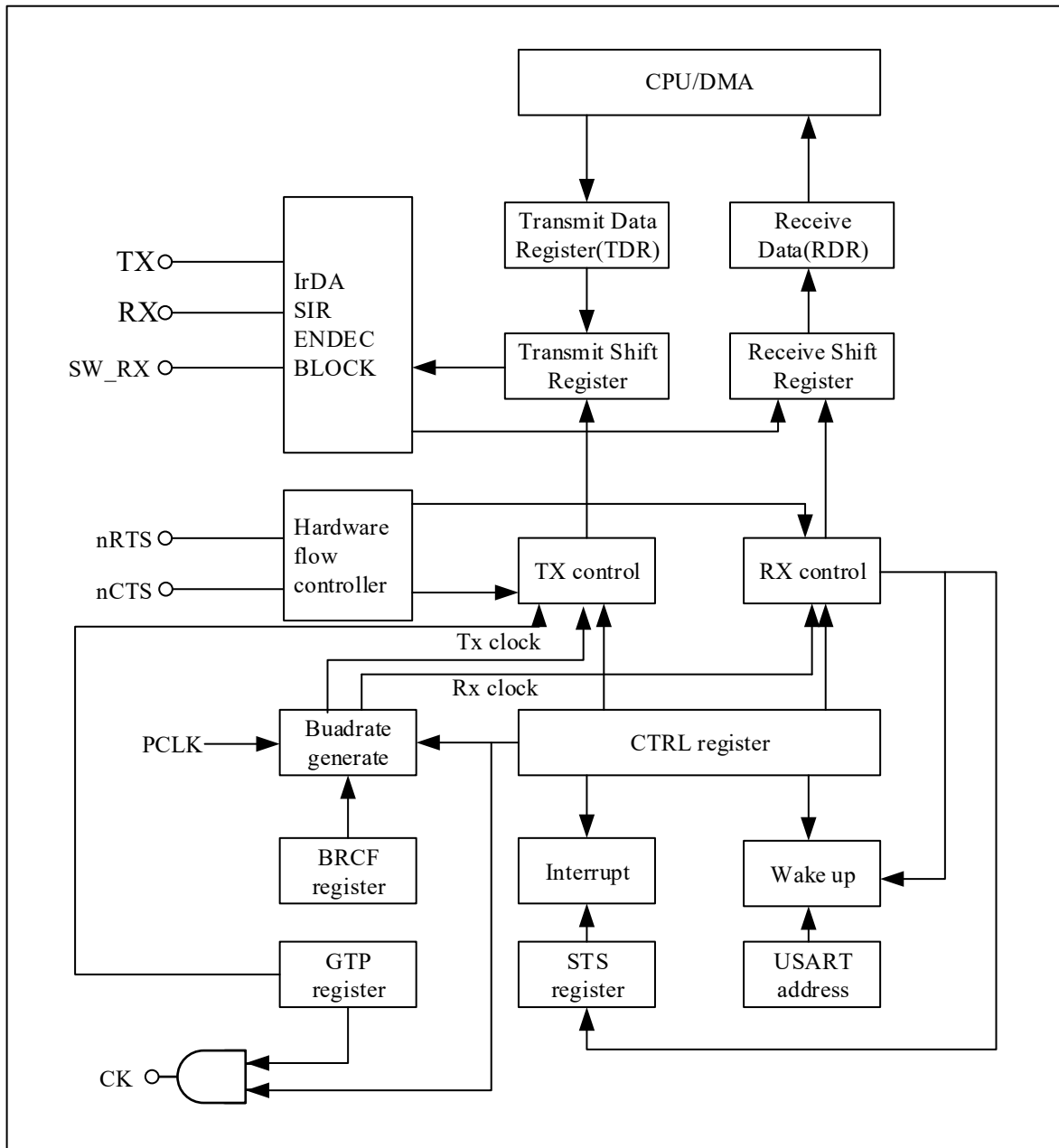
| USART Modes                         | USART1  | USART2  | LPUART  |
|-------------------------------------|---------|---------|---------|
| Asynchronous mode                   | support | support | support |
| Hardware flow control               | support | support | support |
| Multiple buffer communication (DMA) | support | support | support |

| USART Modes                    | USART1  | USART2  | LPUART     |
|--------------------------------|---------|---------|------------|
| Multiprocessor communication   | support | support | nonsupport |
| Synchronous mode               | support | support | nonsupport |
| Smartcard mode                 | support | support | nonsupport |
| Half duplex (Single wire mode) | support | support | nonsupport |
| IrDA                           | support | support | nonsupport |
| LIN                            | support | support | nonsupport |



### 18.3 Functional Block Diagram

Figure 18-1 USART Block Diagram



### 18.4 Function Description

As shown in the Figure 18-1, the bidirectional communication of any USART requires connecting the RX and TX pins to external devices. Among them, TX is the output pin for serial data transmission. When the transmitter is active and not transmitting data, the TX pin is pulled high. When the transmitter is inactive, the TX pin functions as a regular I/O port,

with its state determined by the configured I/O settings.. RX is an input pin for serial data reception, oversampling technique is used when receiving data.

When the device is acting as a transmitter, it transmits data through the TX pin, and as a receiver, it receives data through the RX pin. When there is no data transmission, the bus is in an idle state. Frame format is: 1 start bit + 8 or 9 data bits (least significant bit first) + 1 parity bit (optional) + 0.5,1,1.5 or 2 stop bits.

Use the fractional baud rate generator to configure transmit and receive baud rates .

According to the block diagram, when using the hardware flow control function, the nRTS output and nCTS input pins are required. When the USART receiver is ready to receive new data, nRTS becomes low level. If nCTS is valid (pulled to a low level), the next data is sent, otherwise the next frame of data is not sent.

When using synchronous mode, the CK pin is required. The CK pin is used for clock output for synchronous transmit. Clock phase and polarity are software programmable. During the start and stop bits, the CK pin does not output clock pulses. The CK pin is also used when using Smartcard mode.

**18.4.1 USART Frame Format**

Start bit: 1 bit, active low.Data bits: Configurable via USART\_CTRL1.WL as 8 or 9 bits, with the LSB first.Stop bit: Active high.

Idle frame: a complete data frame consisting of '1's, including the start bit. Followed by the start bit of a data frame containing the data.

Break frame: a break frame is a complete data frame consisting of '0',s including the stop bit. At the end of the break frame, the transmitter inserts 1 or 2 more stop bits ('1') to acknowledge the start bit.

**Figure 18-2 Word Length = 8 Setting**

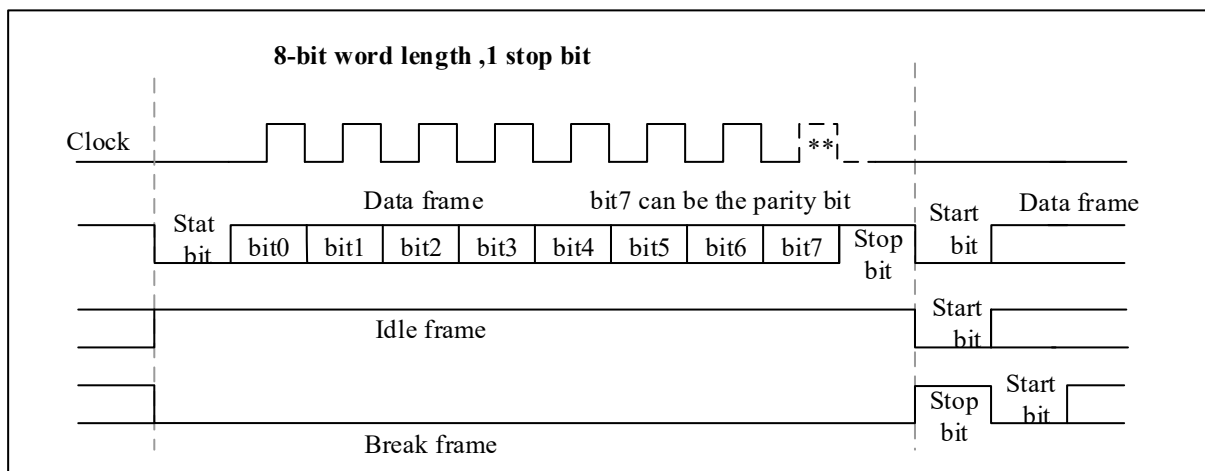
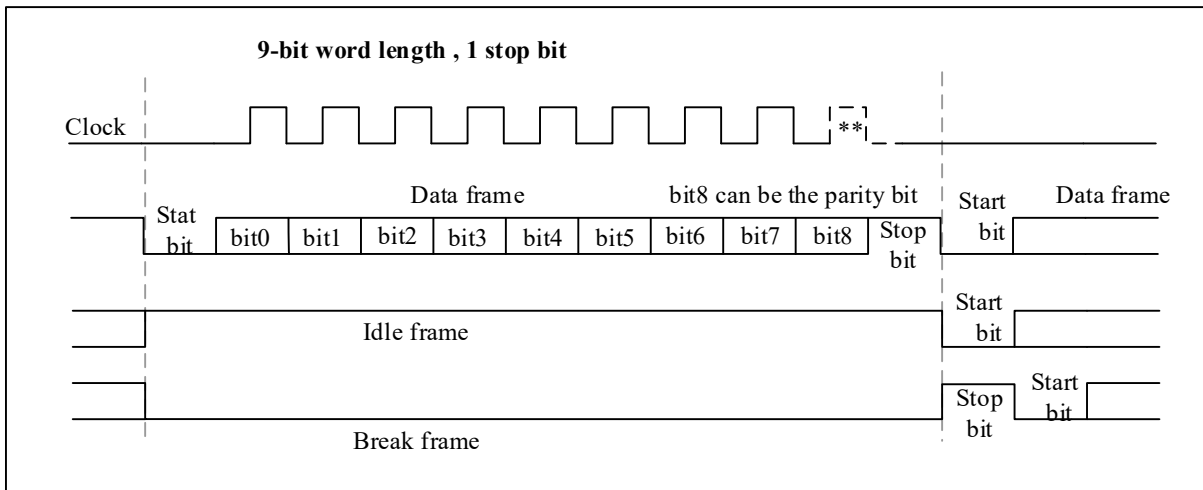


Figure 18-3 Word Length = 9 Setting



### 18.4.2 Transmitter

After the transmitter is enabled, the data in the transmit shift register is transmitted out through the TX pin.

#### 18.4.2.1 Idle frame

Setting USART\_CTRL1.TXEN will cause the USART to transmit an idle frame before the first data frame.

#### 18.4.2.2 Character transmission

Idle frames are followed by characters sent. Before transmitting each character, a start bit (low level) is transmitted. The transmitter transmits 8-bit or 9-bit data according to the configuration of the data bit length, with the least significant bit first. If USART\_CTRL1.TXEN is reset during a data transmitted, it will cause the baud rate counter to stop counting and the data will be corrupted.

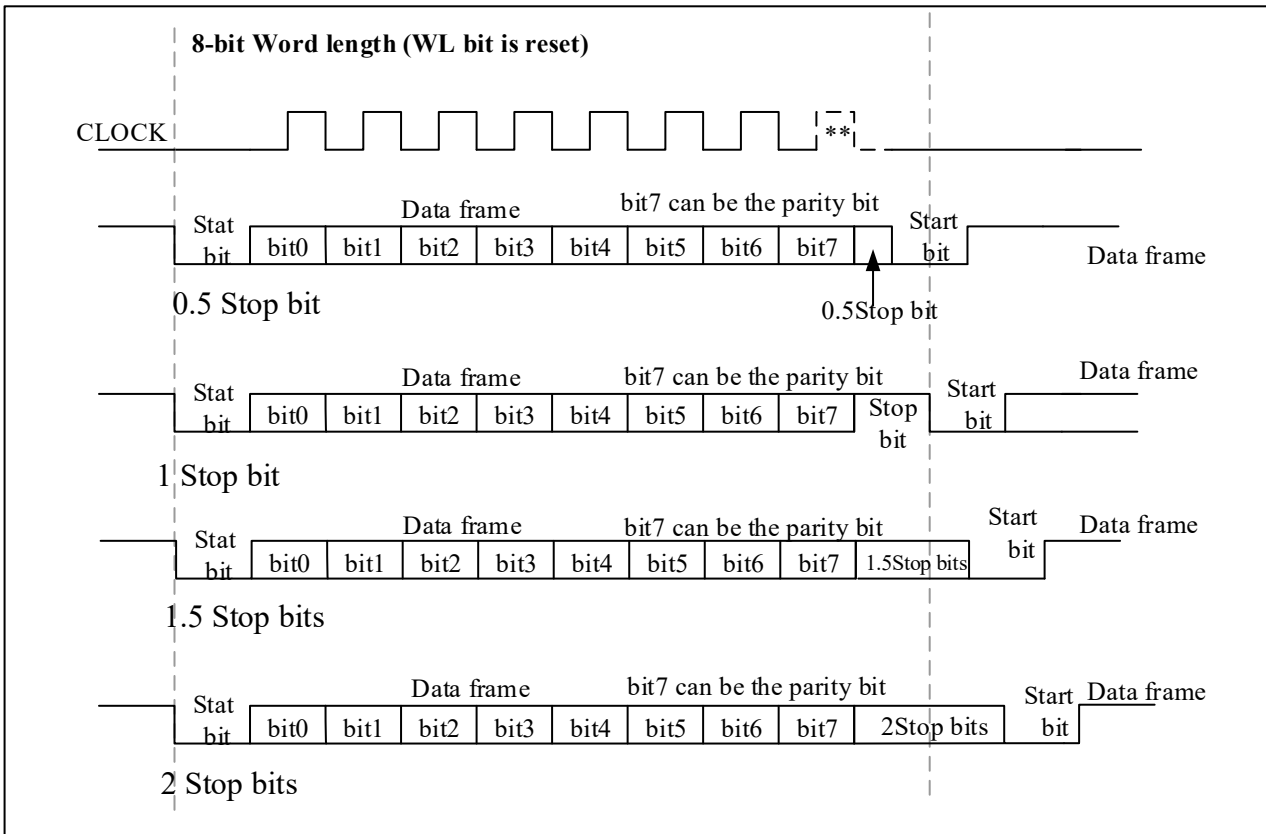
#### 18.4.2.3 Stop bit

The characters are followed by stop bits, the number of which can be configured by setting USART\_CTRL2.STPB[1:0].

Table 18-2 Stop Bit Configuration

| USART_CTRL2.STPB[1:0] | Stop Bit Length (Bits) | Functional Description                               |
|-----------------------|------------------------|--|
| 00                    | 1                      | default  |
| 01                    | 0.5                    | Receiving in Smartcard mode                          |
| 10                    | 2                      | General USART mode, single-wire mode and modem mode. |
| 11                    | 1.5                    | Transmitting and receiving in Smartcard mode         |

Figure 18-4 Configuration Stop Bit



**18.4.2.4 Break frame**

Setting the USART\_CTRL1.SDBRK can transmit the break frame. When there is 8-bit data, the break frame consists of 10 bits of low level; when there is 9-bit data, the break frame consists of 11 bits of low level. After the end of the frame, a stop bit (high level) is inserted.

After the break frame is sent, USART\_CTRL1.SDBRK is cleared by hardware, and the stop bit of the break frame is being sent. Therefore, to transmit a second break frame, USART\_CTRL1.SDBRK should be set after the stop bit of the previous break frame has been sent.

If software resets the USART\_CTRL1.SDBRK bit before starting to transmit the break frame, the break frame will not be sent.

**18.4.2.5 Transmitter process**

1. Set USART\_CTRL1.UEN to enable USART;
2. Configure the transmitter's baud rate, data bit length, parity bit (optional), the number of stop bits and DMA

configuration;

3. Enable the transmitter (USART\_CTRL1.TXEN);
4. Transmit each data to the USART\_DAT register through the CPU or DMA, and the write operation to the USART\_DAT register will clear USART\_STS.TXDE;
5. After writing the last data in the USART\_DAT register, wait for USART\_STS.TXC =1, which indicates the end of the transmission of the last data frame.

#### 18.4.2.6 Single byte communication

A write to the USART\_DAT register will clear the USART\_STS.TXDE bit.

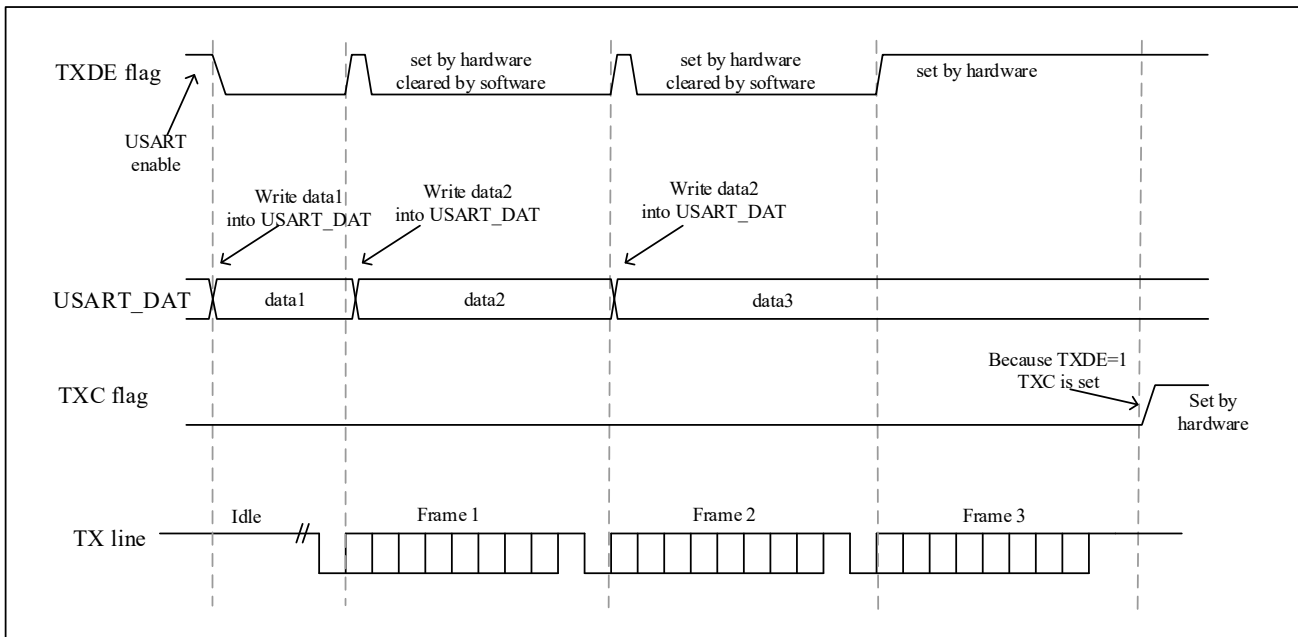
The USART\_STS.TXDE bit is set by hardware when the data in the TDR register is transmitted to the transmit shift register (indicating that data is being transmitted). An interrupt will be triggered if USART\_CTRL1.TXDEIEN is set. At this point, the next data can be sent to the USART\_DAT register because the TDR register has been cleared and will not overwrite the previous data.

Write operation to USART\_DAT register:

- When the transmit shift register is not transmitting data and is in an idle state, the data is directly put into the shift register for transmission, and the USART\_STS.TXDE bit is set by hardware;
- When the transmit shift register is transmitting data, the data is stored in the TDR register, and after the current transmission is completed, the data is put into the shift register.

When a frame containing data is sent and USART\_STS.TXDE=1, the USART\_STS.TXC bit is set to '1' by hardware. An interrupt is triggered if USART\_CTRL1.TXCIEN is '1'. USART\_STS.TXC bit is cleared by a software sequence (read USART\_STS register first, then write USART\_DAT register).

Figure 18-5 TXC/TXDE Changes During Transmission



### 18.4.3 Receiver

#### 18.4.3.1 Start bit detection

When the received sampling sequence is: 1 1 1 0 X 0 X 0 X 0 0 0 0, it is considered that a start bit is detected.

The samples at the 3rd, 5th, and 7th bits, and the samples at the 8th, 9th, and 10th bits are all '0' (that is, 6 '0'), the start bit is confirmed received, and the USART\_STS.RXDNE flag bit is set, but the NEF noise flag is not set. If USART\_CTRL1.RXDNEIEN=1, an interrupt will be triggered.

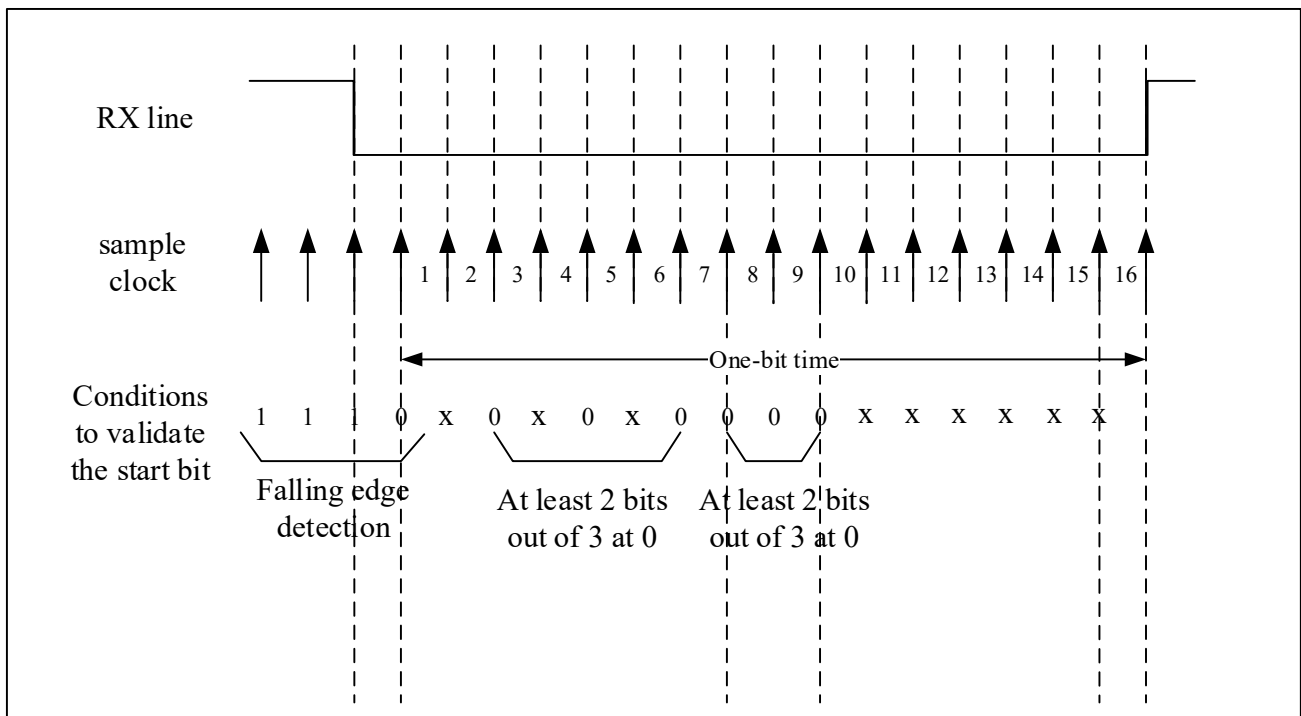
If there are six '0' samples at the 3rd, 5th, 7th bits, and at the 8th, 9th, 10th bits, a start bit is confirmed to have been received, and USART\_STS.RXDNE is set to 1, but the NE noise flag will not be set. If USART\_CTRL1.RXDNEIEN has been set to 1, an interrupt will be generated.

If there are two '0' samples at the 3rd, 5th, 7th bits, and at the same time, there are two '0' samples at the 8th, 9th, 10th bits, a start bit is also confirmed to have been received, but the NE noise flag will be set.

If there are three '0' samples at the 3rd, 5th, 7th bits, and at the same time, there are two '0' samples at the 8th, 9th, 10th bits, a start bit is also confirmed to have been received, and the NE noise flag will be set.

If there are two '0' samples at the 3rd, 5th, 7th bits, and at the same time, there are three '0' samples at the 8th, 9th, 10th bits, a start bit is also confirmed to have been received, and the NE noise flag will be set.

Figure 18-6 Start Bit Detection



### 18.4.3.2 Stop bit description

The number of data stop bits can be configured by the `USART_CTRL2.STPB[1:0]`. In normal mode, 1 or 2 stop bits can be selected. In Smartcard mode, 0.5 or 1.5 stop bits can be selected.

1. 0.5 stop bits (receive in Smartcard mode): no sampling is performed on the stop bit. Therefore, frame errors and framing breaks cannot be detected at this time.
2. 1 stop bit: the sampling of one stop bit is done through three points, and the 8th, 9th and 10th sampling bits are selected.
3. 1.5 stop bits (Smartcard mode): when transmitting in Smartcard mode, the device must check whether the data is transmitted correctly. So the receiver function block must be activated (`USART_CTRL1.RXEN=1`) and sample the signal on the RX line during the transmission of the stop bit. If a parity error occurs, the Smartcard will pull down the TX when the transmitter samples the NACK signal to indicate that a framing error has occurred. The `USART_STS.FEF` is set together with the `USART_STS.RXDNE` at the end of the 1.5th stop bit. The 1.5 stop bits are sampled at points 16, 17 and 18. The 1.5 stop bits can be divided into two parts: one is 0.5 clock cycles, during which nothing happens. This is followed by the stop bit of 1 clock cycle, which is sampled by receiver. For details, refer to 18.4.14 Smartcard mode.

4. 2 stop bits: the sampling of the 2 stop bits is completed at the 8th, 9th and 10th sampling points of the first stop position. If a frame error is detected during the first stop bit, the frame error flag is set. During the second stop bit period, receiver does not detect framing error. The USART\_STS.RXNE flag will be set at the end of the first stop bit.

#### 18.4.3.3 Receiver process

1. Enable USART\_CTRL1.UEN to activate USART;
  2. Configure the receiver's baud rate, data bit length, parity bit (optional), stop bit number or DMA configuration;
  3. Activate the receiver (USART\_CTRL1.RXEN) and start detecting the start bit;
  4. The receiver receives 8-bit or 9-bit data according to the configuration of the data bit length, and the least significant bit of the data is first shifted from the RX pin into the receive shift register;
  5. When the data of the received shift register is moved to the RDR register, USART\_STS.RXDNE is set, and the data can be read out. If USART\_CTRL1.RXNEIEN is 1, an interrupt will be triggered;
  6. When an overflow error, noise error, or frame error is detected in the received frame, the corresponding error flag status bit will be set. If USART\_CTRL1.RXEN is reset during data transmission, the data being received will be lost;
  7. USART\_STS.RXDNE is set after receiving data, and a read operation to USART\_DAT can clear this bit:
- During multi-buffer communication, the data register is cleared by the DMA read operation;
  - During single-buffer communication, it is cleared by software reading the USART\_DAT register.

#### 18.4.3.4 Idle frame detection

The receiver of the USART can detect idle frames. An interrupt is triggered if USART\_CTRL1.IDLEIEN is '1'. USART\_STS.IDLEF bit is cleared by a software sequence (read USART\_STS register first, then read USART\_DAT register).

#### 18.4.3.5 Break frame detection

The frame error flag(USART\_STS.FEF) is set by hardware when the receiver detects a break frame. It can be cleared by a software sequence (read USART\_STS register first, then read USART\_DAT register).

#### 18.4.3.6 Framing error

A framing error occurs when a stop bit is not received or recognized at the expected time. At this time, the frame error flag USART\_STS.FEF will be set by hardware, and the invalid data will be transferred from the shift register to the



USART\_DAT register. During single-byte communication, no framing error interrupt will be triggered because at this point, the USART\_STS.RXDNE bit is set to 1, which will trigger the interrupt. In multi-buffer communication mode, an interrupt will be triggered if the USART\_CTRL3.ERRIEN bit is set.

#### 18.4.3.7 Overrun error

If USART\_STS.RXDNE is still '1', when the data currently received in the shift register needs to be transferred to the RDR register, an overflow error will be detected, and the hardware will set USART\_STS.OREF. If this bit is set, the value in the RDR register will be not lost, but the data in the shift register will be overwritten. It can be cleared by a software sequence (read USART\_STS register first, then read USART\_DAT register).

If an overflow error occurs, USART\_STS.RXDNE will be '1', and an receive interrupt will be triggered. If the USART\_CTRL3.ERRIEN bit is set, an error interrupt will be triggered when the USART\_STS.OREF flag is set in multi-buffer communication mode.

#### 18.4.3.8 Noise error

USART\_STS.NEF is set by hardware when noise is detected on a received frame. It can be cleared by software sequence (read USART\_STS register first, then write USART\_DAT register). During single-byte communication, no noise error interrupt will be triggered because at this point, the USART\_STS.RXDNE bit is set to 1, which will trigger the interrupt. In multi-buffer communication mode, an interrupt is triggered when the USART\_STS.NEF flag is set if the USART\_CTRL3.ERRIEN bit is set.

**Table 18-3 Data Sampling for Noise Detection**

| Sample Value | NE Status | Received Bits | Data Validity |
|--------------|-----------|---------------|---------------|
| 000          | 0         | 0             | Effective     |
| 001          | 1         | 0             | be invalid    |
| 010          | 1         | 0             | be invalid    |
| 011          | 1         | 1             | be invalid    |
| 100          | 1         | 0             | be invalid    |
| 101          | 1         | 1             | be invalid    |
| 110          | 1         | 1             | be invalid    |
| 111          | 0         | 1             | Effective     |

### 18.4.4 Generation of Fractional Baud Rate

The baud rate of the USART can be configured in the USART\_BRCF register. This register defines the integer and fractional parts of the baud rate divider. The baud rate of the transmitter and receiver should be configured to the same value. Be careful not to change the value of the USART\_BRCF register during communication, because the baud rate counter will be replaced by the new value of the baud rate register.

$$\text{TX / RX baud rate} = f_{\text{PCLK}} / (16 * \text{USARTDIV})$$

where  $f_{\text{PCLK}}$  is the clock provided to the peripheral:

- PCLK1 is used for USART2, up to 48MHz;
- PCLK2 is used for USART1, up to 48 MHz.

USARTDIV is an unsigned fixed-point number.

#### 18.4.4.1 USARTDIV and USART\_BRCF register configuration

Example 1:

If DIV\_Integer = 27, DIV\_Decimal = 12 (USART\_BRCF = 0x1BC), then

$$\text{DIV\_Integer(USARTDIV)} = 27$$

$$\text{DIV\_Decimal(USARTDIV)} = 12/16 = 0.75$$

$$\text{So USARTDIV} = 27.75$$

Example 2:

Requirements USARTDIV = 25.62, there are:

$$\text{DIV\_Decimal} = 16 * 0.62 = 9.92$$

Closest integer is: 10 = 0x0A

$$\text{DIV\_Integer} = \text{DIV\_Integer}(25.620) = 25 = 0x19$$

$$\text{So USART\_BRCF} = 0x19A$$

Example 3:

Requirements USARTDIV = 50.99, there are:

$$\text{DIV\_Decimal} = 16 * 0.99 = 15.84$$

Closest integer: 16 = 0x10 => DIV\_Decimal[3:0] overrun => carry must be added to the fractional part

$$\text{DIV\_Integer} = \text{DIV\_Integer}(0d50.990 + \text{carry}) = 51 = 0x33$$

$$\text{So USART\_BRCF} = 0x330, \text{USARTDIV} = 0d51.00$$

**Table 18-4 Error Calculation When Setting Baud Rate**

| Baud Rate     |       | f <sub>CLK</sub> = 36MHz |                       |            | f <sub>CLK</sub> = 48MHz |                       |          |
|---------------|-------|--------------------------|-----------------------|------------|--------------------------|-----------------------|----------|
| serial number | Kbps  | Reality                  | Set value in register | Error(%)   | Reality                  | Set value in register | Error(%) |
| 1             | 2.4   | 2.4                      | 937.5                 | 0%         | 2.4                      | 1250                  | 0%       |
| 2             | 9.6   | 9.6                      | 234.375               | 0%         | 9.6                      | 312.5                 | 0%       |
| 3             | 19.2  | 19.2                     | 117.1875              | 0%         | 19.2                     | 156.25                | 0%       |
| 4             | 57.6  | 57.6                     | 39.0625               | 0%         | 57.623                   | 52.0625               | 0.04%    |
| 5             | 115.2 | 115.384                  | 19.5                  | 0.15%      | 115.1                    | 26.0625               | 0.08%    |
| 6             | 230.4 | 230.769                  | 9.75                  | 0.16%      | 230.769                  | 13                    | 0.16%    |
| 7             | 460.8 | 461.538                  | 4.875                 | 0.16%      | 461.538                  | 6.5                   | 0.16%    |
| 8             | 921.6 | 923.076                  | 2.4375                | 0.16%      | 923.076                  | 3.25                  | 0.16%    |
| 9             | 2250  | 2250                     | 1                     | 0%         | 2285.714                 | 1.3125                | 1.58%    |
| 10            | 3000  | impossible               | impossible            | impossible | 3000                     | 1                     | 0%       |

Note: The lower the clock frequency of the CPU, the lower the error for a particular baud rate.

### 18.4.5 Receiver's Tolerance Clock Deviation

Variations due to transmitter errors (including transmitter side oscillator variations), receiver side baud rate rounding errors, receiver side oscillator variations, variations due to transmission lines (This is usually caused by inconsistencies in the timing of data rising and falling edges.), these factors will affect the overall clock system variation. Only when the sum of the above four changes is less than the tolerance of the USART receiver, the USART asynchronous receiver can operate normally.

During receiving data normally, the tolerance of the USART receiver depends on the selection of the data bit length and whether fractional baud rate divider is used. The tolerance of the USART receiver is equal to the maximum tolerable variation.

**Table 18-5 When DIV\_Decimal = 0. Tolerance of USART Receiver**

|        |                |                  |
|--------|----------------|------------------|
| WL Bit | NF Is An Error | NF Is Don't Care |
|--------|----------------|------------------|

|   |       |        |
|---|-------|--------|
| 0 | 3.75% | 4.375% |
| 1 | 3.41% | 3.97%  |

**Table 18-6 When DIV\_Decimal != 0. Tolerance of USART Receiver**

| WL Bit | NF Is An Error | NF Is Don't Care |
|--------|----------------|------------------|
| 0      | 3.33%          | 3.88%            |
| 1      | 3.03%          | 3.53%            |

### 18.4.6 Parity Control

Parity can be enabled by configuring the USART\_CTRL1.PCEN bit.

When the parity bit is enabled for transmission, a parity bit is generated on transmission, and a parity bit is checked on reception.

**Table 18-7 Frame Format**

| WL Bit | PCEN Bit | USART Frame  |
|--------|----------|--|
| 0      | 0        | Start bit   8-bit data   Stop bit                  |
| 0      | 1        | Start bit   7 bits of data   Parity bit   Stop bit |
| 1      | 0        | Start bit   9-bit data   Stop bit                  |
| 1      | 1        | start bit   8-bit data   parity bit   stop bit     |

#### Even parity

Configure USART\_CTRL1.PSEL to 0, and even parity can be selected.

Make the number of '1' in the transmitted data (including parity bit) be an even number. For example: if Data=11000101, there are 4 '1', then the parity bit will be '0' (4 '1' in total). The receiver calculates the number of '1's in the data again. If it is an even number, the check is passed, indicating that no errors occurred during the transmission process. If it is not even number, it means that an error has occurred, the USART\_STS.PEF flag is set to '1', and if USART\_CTRL1.PEIE is enabled, an interrupt is triggered.

#### Odd parity

Configure USART\_CTRL1.PSEL to 1, you can choose odd parity.

Make the number of '1' in the transmitted data (including parity bit) be an odd number. For example: if Data=11000101,

there are 4 '1', then the parity bit will be '1' (5 '1' in total). The receiver calculates the number of '1's in the data again. If it is an odd number, the check is passed, indicating that no errors occurred during the transmission process. If it is not an odd number, it means that an error has occurred, the USART\_STS.PEF flag is set to '1', and if USART\_CTRL1.PEIE is enabled, an interrupt is triggered.

### 18.4.7 DMA Communication

The USART supports the DMA mode using multi-buffer configuration, which can realize high-speed data communication.

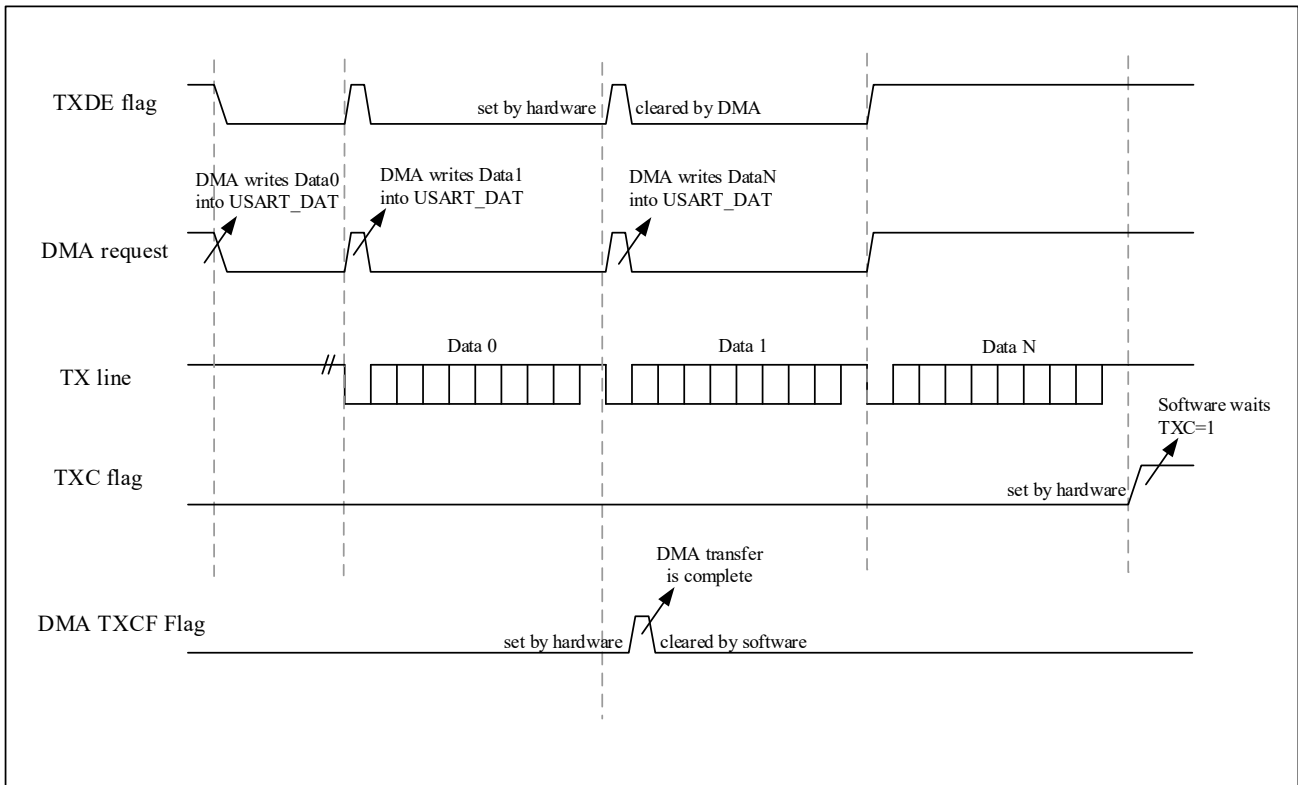
#### 18.4.7.1 DMA transmission

Set USART\_CTRL3.DMATXEN to enable DMA mode when transmitting. When the USART's transmit shift register is empty (USART\_STS.TXDE=1), the DMA will transfer the data from the SRAM to the USART\_DAT register of the USART.

When using DMA transmission, the process of configuring the DMA channel is as follows:

1. Set the address of the data memory. When a data transfer request occurs, the transferred data will be read from this address.
2. Set the address of the USART\_DAT register. When a data transfer request occurs, this address will be the destination address of the data transfer.
3. Set the amount of data to transfer.
4. Set the priority of the channel, set whether to use the cyclic mode, the incremental mode of peripherals and memory, the data width of peripherals and memory, the interrupt generated by half of the transfer or the interrupt when the transfer is completed.
5. Start the selected DMA channel.
6. After the data transfer is completed, the transfer complete flag (DMA\_INTSTS.TXCFx) is set to 1.

Figure 18-7 Transmission Using DMA



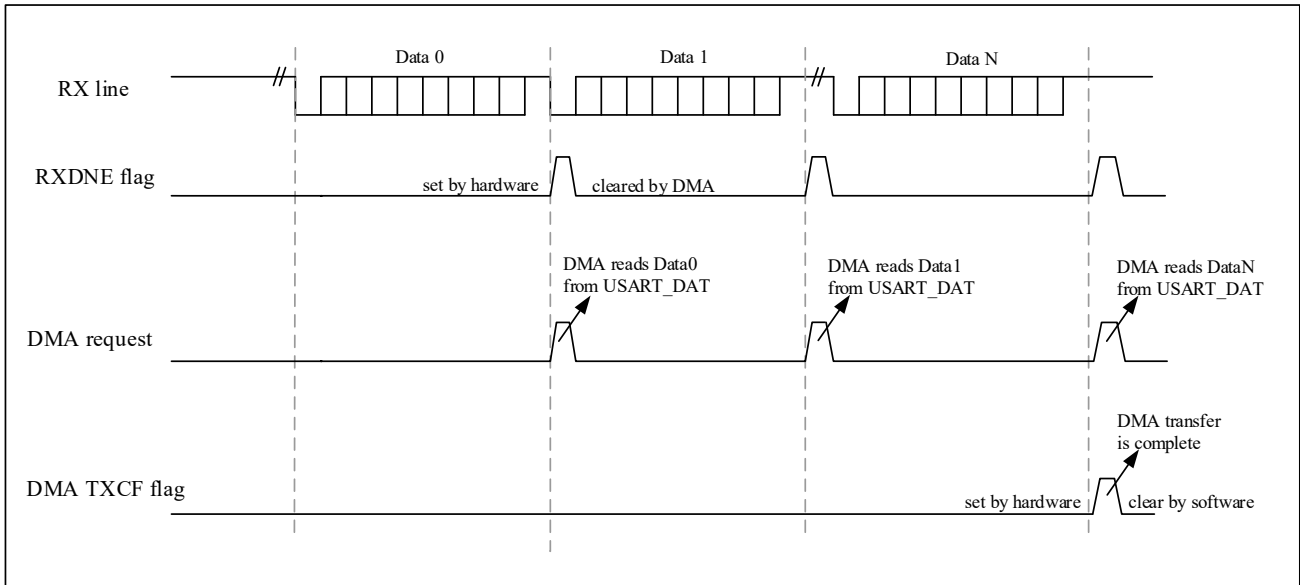
### 18.4.7.2 DMA reception

Set `USART_CTRL3.DMARXEN` to enable DMA mode when receiving. When a byte is received (`USART_STS.RXDNE=1`), the DMA will transfer the data from the `USART_DAT` register of the USART to the SRAM.

When using DMA reception, the process of configuring the DMA channel is as follows:

1. Set the address of the `USART_DAT` register. When a data transfer request occurs, this address will be the source address of the data transfer.
2. Set the address of the data memory. When a data transfer request occurs, the transferred data will be written to this address.
3. Set the amount of data to transfer.
4. Set the priority of the channel, set whether to use the cyclic mode, the incremental mode of peripherals and memory, the data width of peripherals and memory, the interrupt generated by half of the transfer or the interrupt when the transfer is completed.
5. Start the selected DMA channel.

Figure 18-8 Reception Using DMA

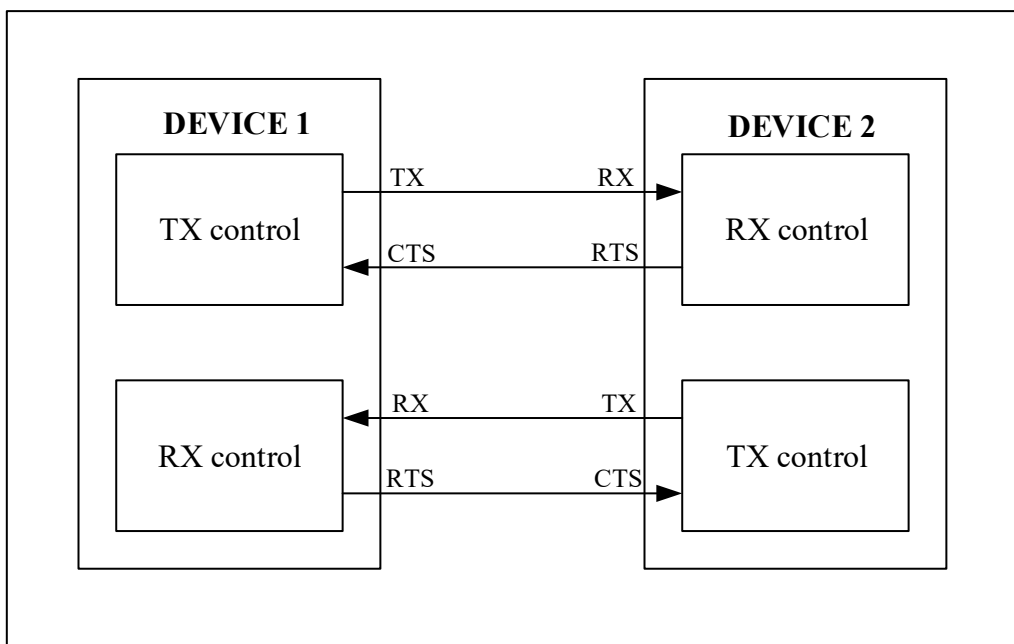


In multi-buffer communication mode, the error flag will be set when there is a frame error, overrun or noise error. An interrupt will be triggered if the error interrupt is enabled (USART\_CTRL3.ERRIEN=1).

### 18.4.8 Hardware Flow Control

USART supports hardware flow control. The purpose is to coordinate the transmitting and receiving parties so that the data will not be lost. The connection method is shown in the following figure.

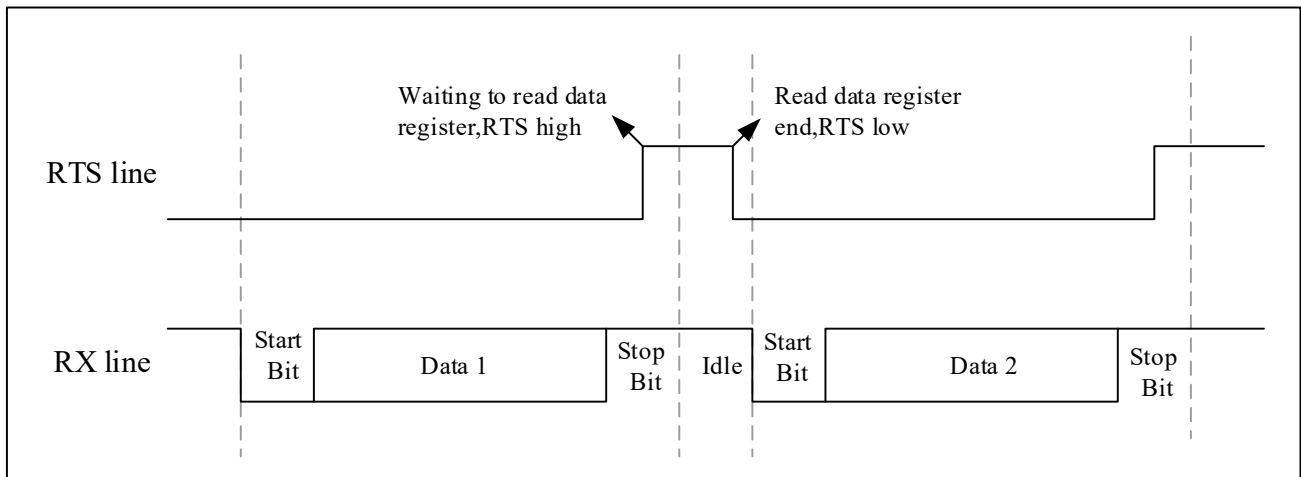
Figure 18-9 Hardware Flow Control Between Two USART



**18.4.8.1 RTS flow control**

Set USART\_CTRL3.RTSEN to enable RTS. RTS is the output signal used to indicate that the receiver is ready. When data arrives in RDR, nRTS is asserted, notifying the transmitter to stop data transmission at the end of the current frame. When receiver is ready to receive new data, nRTS is deasserted.

**Figure 18-10 RTS Flow Control**



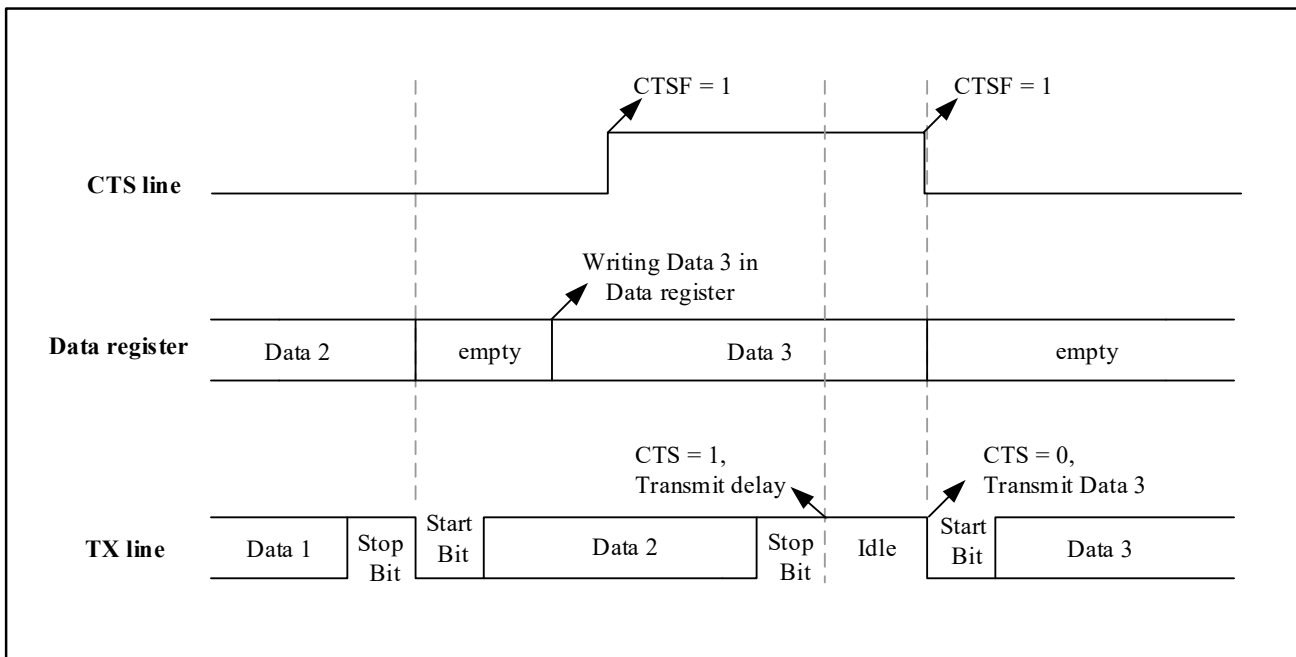
**18.4.8.2 CTS flow control**

Set USART\_CTRL3.CTSEN to enable CTS. CTS is an input signal, used to judge whether data can be sent to the other device. The low level is valid, and the low level indicates that the device can transmit data to the other device. If the nCTS signal becomes invalid during data transmission, the transmission will stop after transmitting the data. If you write data to the data register when nCTS is invalid, the data will not be sent until nCTS is valid.

If the USART\_CTRL3.CTSEN bit is set, the USART\_STS.CTSF bit will be set by hardware when the nCTS input changes state. An interrupt will be triggered if USART\_CTRL3.CTSIEN is enabled.



Figure 18-11 CTS Flow Controls



### 18.4.9 Multiprocessor Communication

USART allows multiprocessor communication. When multiple processors communicate through USART, it is necessary to determine who is the master device, and the remaining processors are all slave devices. The TX output of the master device is directly connected to the RX port of all slave device. The TX outputs of the slaves are logically AND together and connected to the RX inputs of the master.

When multi-processor communication is performed, the slave devices are all in mute mode, and the host uses a specific method to wake up a slave device to be communicated when needed, so that the slave device is in an active state and transmits data with the master device.

The USART can be woken up from mute mode by idle line detection or address mark detection.

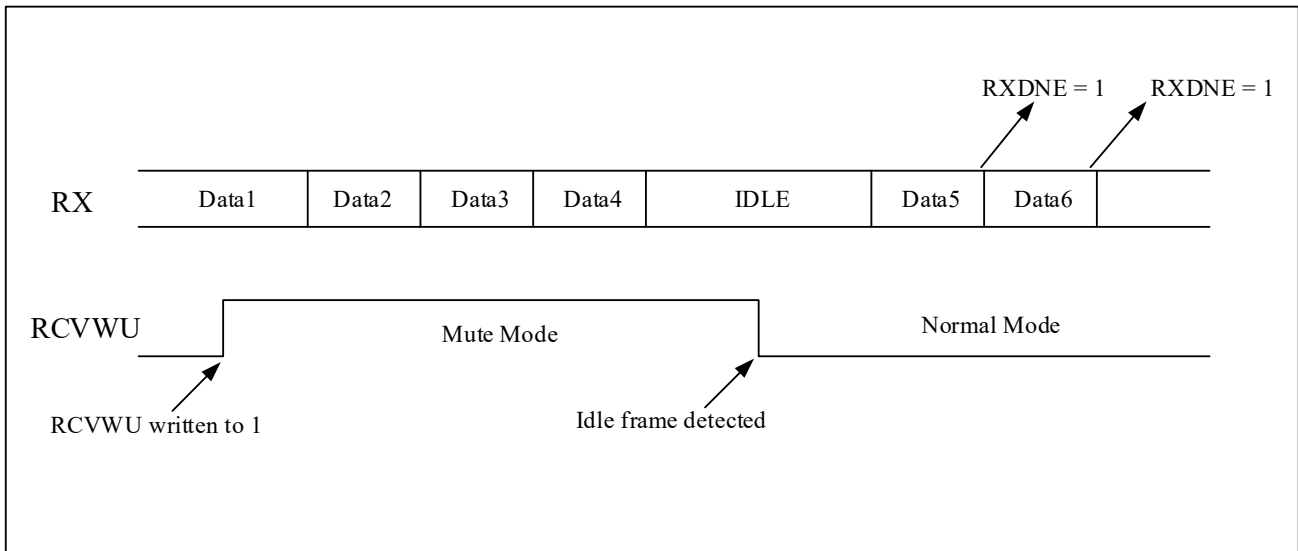
#### 18.4.9.1 Idle line detection

The idle line detection configuration process is as follows:

1. Clear the USART\_CTRL1.WUM bit to 0, and the USART performs idle line detection;
2. When USART\_CTRL1.RCVWU is set (which can be automatically controlled by hardware or written by software under certain conditions), USART enters mute mode. In mute mode, the receive status flag is not set, and all receive interrupts are disabled;
3. As shown in the Figure 18-12 below, when an idle frame is detected, USART is woken up, and then

USART\_CTRL1.RCVWU is cleared by hardware. At this time, USART\_STS.IDLEF is not set.

Figure 18-12 Mute Mode Using Idle Line Detection



18.4.9.2 Address mark detection

By configuring the USART\_CTRL1.WUM bit to 1, the USART performs address mark detection. The address of the receiver is programmable through the USART\_CTRL2.ADDR[3:0] bits. If the most significant bit (MSB) of the received data is 1, the current data is an address with the lower 4 bits being valid, otherwise the current data is considered as normal data.

In this mode, the USART can enter mute mode by:

- When the receiver does not contain data, USART\_CTRL1.RCVWU can be written to 1 by software, and USART enters mute mode;

*Note: When the receive buffer contains no data (RXNE=0 in USART\_SR), the USART\_CTRL1.RCVWU bit can be written to 0 or 1. Otherwise, the write operation is ignored.*

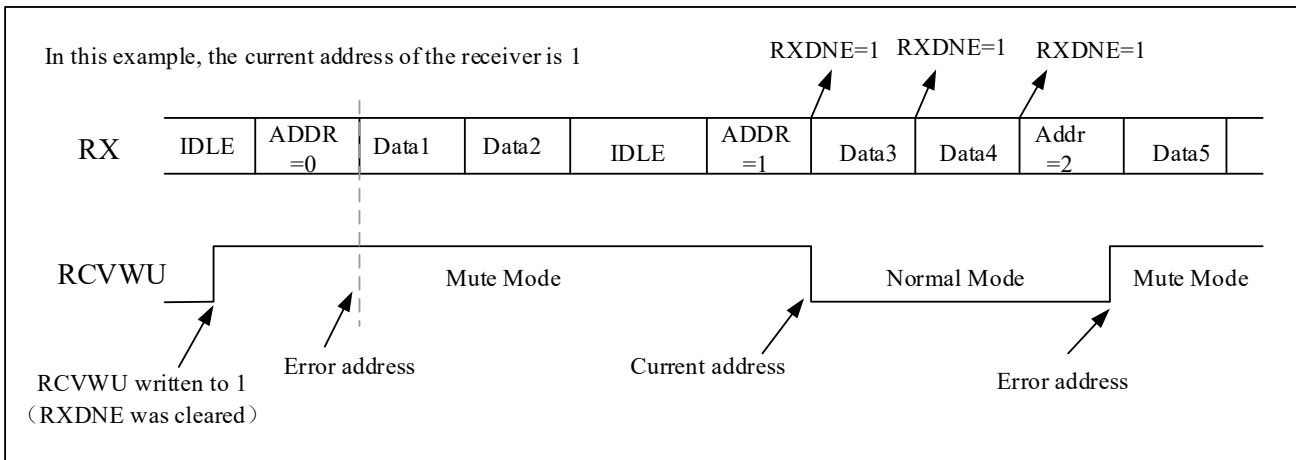
- When the received address does not match the address of the USART\_CTRL2.ADDR[3:0] bits, USART\_CTRL1.RCVWU is set to 1 by hardware.

In mute mode, none of the receive status bits are set and all receive interrupts are disabled.

When the received address matches the address of the USART\_CTRL2.ADDR[3:0] bits, the USART is woken up and USART\_CTRL1.RCVWU is cleared. The USART\_STS.RXDNE bit will be set when this matching address is received.

Data can then be transmitted normally.

Figure 18-13 Mute Mode Detected Using Address Mark



### 18.4.10 Synchronous Mode

USART supports synchronous serial communication. The USART only supports the master mode, and cannot use the input clock from other devices to receive and transmit data. Synchronous mode can be enabled by configuring the USART\_CTRL2.CLKEN bit.

*Note: When using synchronous mode, USART\_CTRL2.LINMEN, USART\_CTRL3.SCMEN, USART\_CTRL3.HDMEN, USART\_CTRL3.IRDAMEN, these bits need to be kept clear.*

#### 18.4.10.1 Synchronous clock

The CK pin is the output of the USART transmitter clock. During the bus idle period, before the actual data arrives and when the break symbol is sent, the clock not output.

Clock phase and polarity are software programmable and need to be configured when both the transmitter and receiver are disabled.

When the clock polarity is 0 (USART\_CTRL2.CLKPOL=0), the default level of CLK is low; when the clock polarity is 1 (USART\_CTRL2.CLKPOL=1), the default level of CLK is high. When the phase polarity is 0 (USART\_CTRL2.CLKPHA=0), the data is sampled on the first edge of the clock; when the phase polarity is 1 (USART\_CTRL2.CLKPHA=1), the data is sampled on the second edge.

During the start and stop bits, the CK pin does not output clock pulses.

A sync data cannot be received when no data is sent. Because the clock is only available when the transmitter is activated

and data is written to the USART\_DAT register.

The USART\_CTRL2.LBCLK bit controls whether the most significant bit (MSB) of the data byte has a clock pulse. This bit needs to be configured when both the transmitter and receiver are disabled. If USART\_CTRL2.LBCLK is 1, the clock pulse of the last bit of data will be output from CK. If USART\_CTRL2.LBCLK is 0, the clock pulse of the last bit of data is not output from CK.

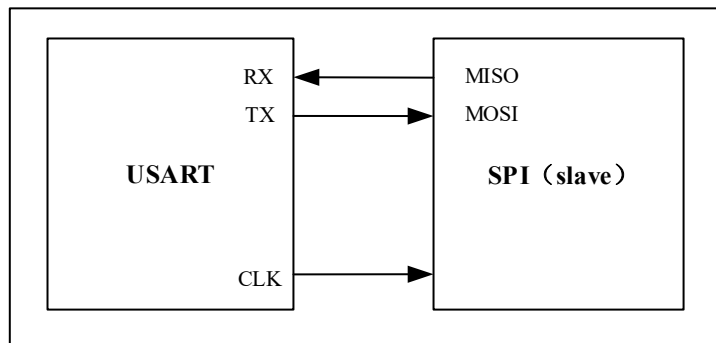
**18.4.10.2 Synchronous transmitting**

The transmitter in synchronous mode operates the same as in asynchronous mode. Data on the TX pin is transmitted out synchronously with CK.

**18.4.10.3 Synchronous receiving**

The receiver in synchronous mode operates differently than in asynchronous mode. Data is sampled on CK without any oversampling. But setup time and hold time (depending on baud rate, 1/16 bit time) must be considered.

**Figure 18-14 USART Synchronous Transmission Example**



**Figure 18-15 USART Data Clock Timing Example (WL=0)**

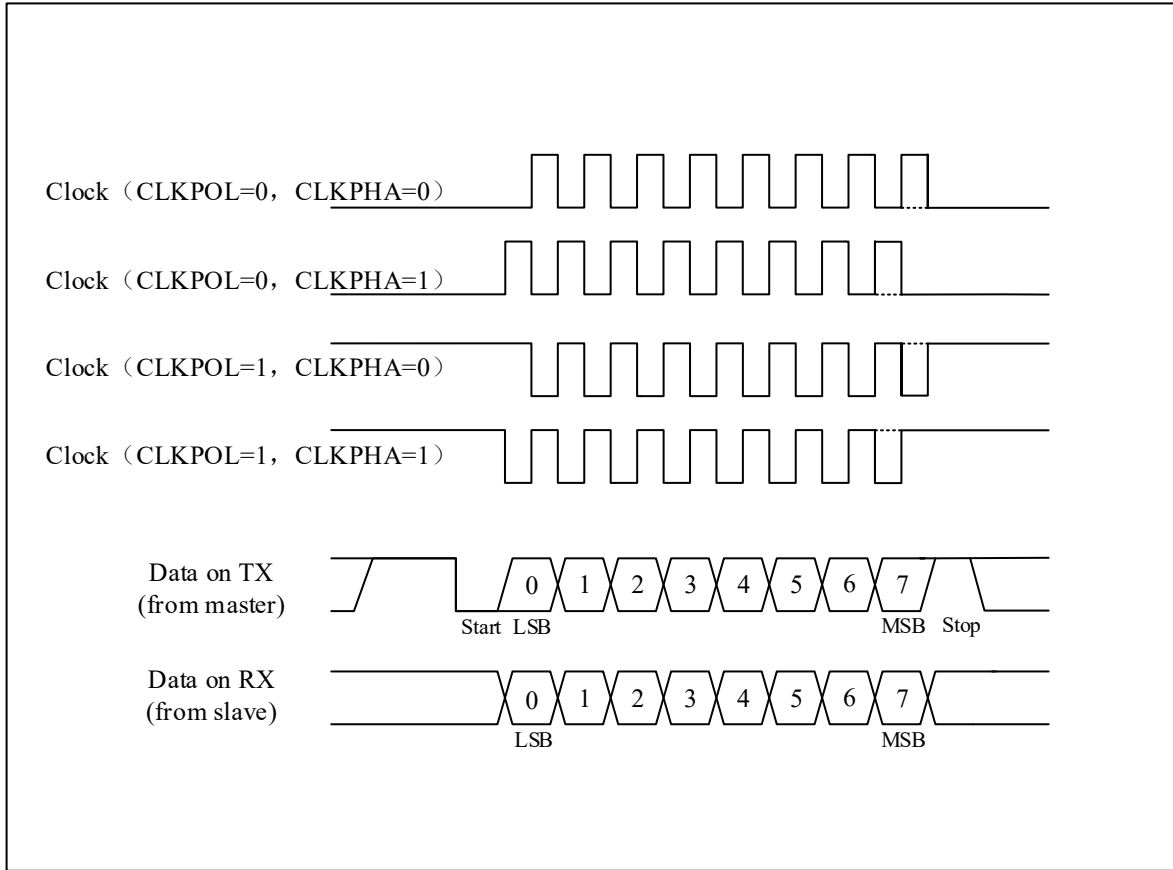


Figure 18-16 USART Data Clock Timing Example (WL=1)

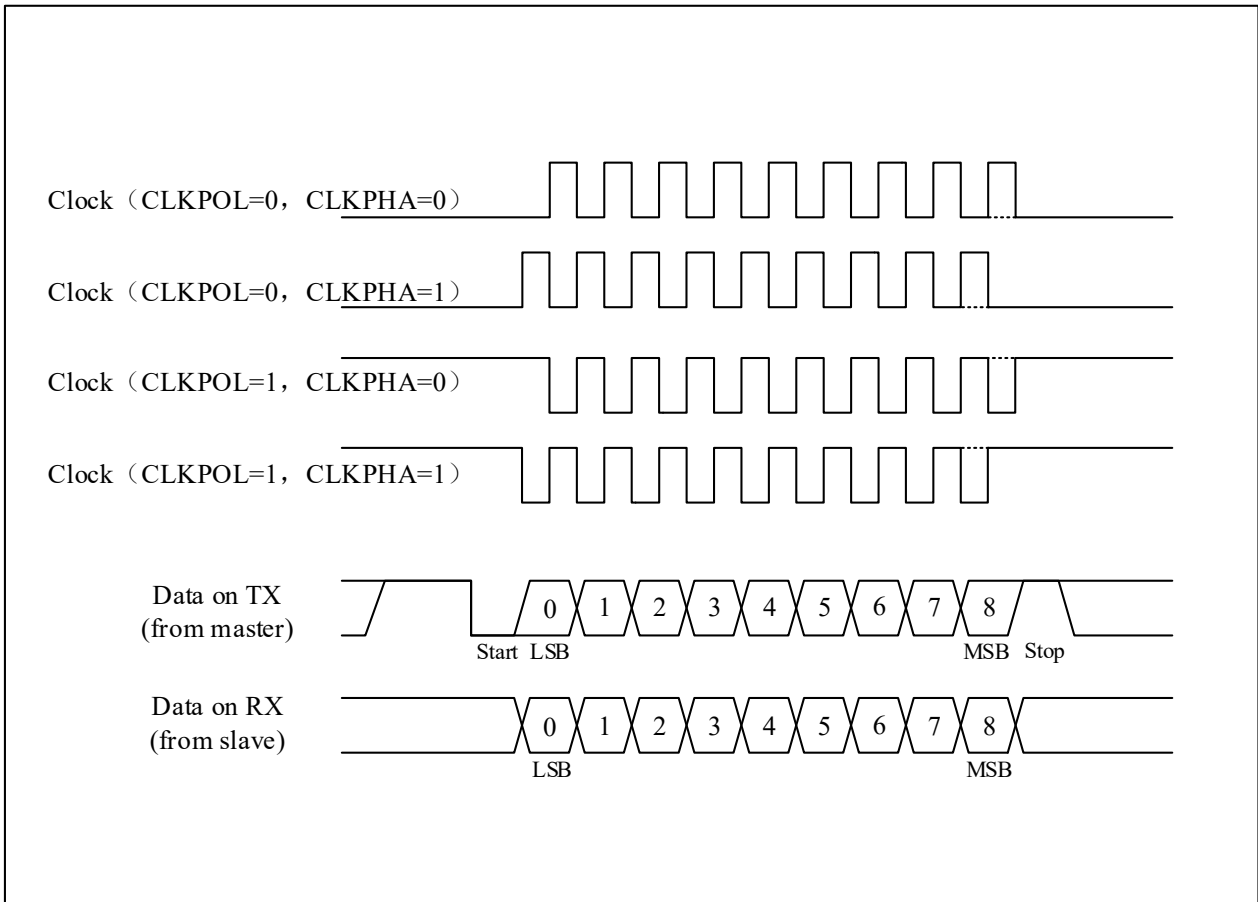
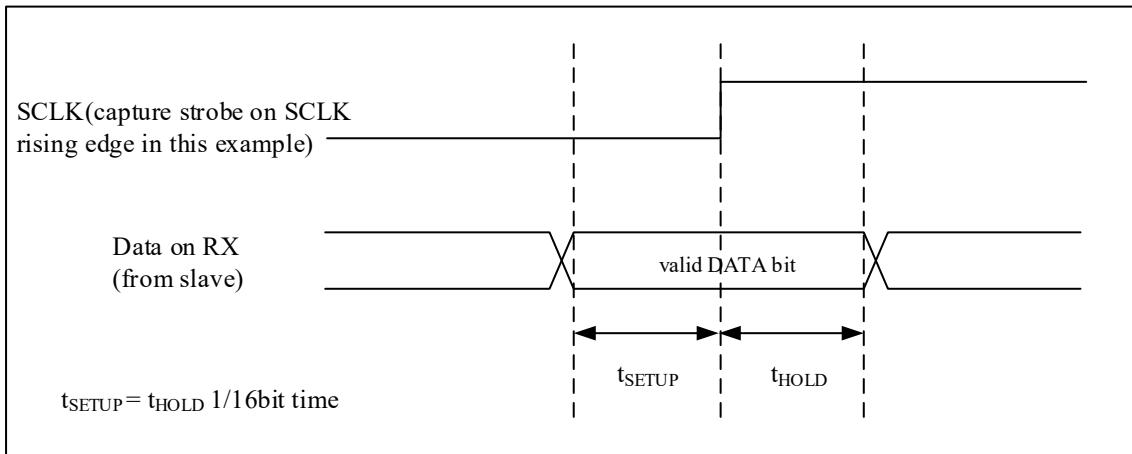


Figure 18-17 RX Data Sampling/Holding Time



Note: the function of CK is different in Smartcard mode, please refer to the Smartcard mode section for details.

### 18.4.11 Single-wire Half-duplex Mode

USART supports single-wire half-duplex communication, allowing data to be transmitted in both directions, but only

allows data to be transmitted in one direction at the same time. Communication conflicts are managed by software.

Through the USART\_CTRL3.HDMEN bit, you can choose whether to enable half-duplex mode. When using single-wire half-duplex, USART\_CTRL2.CLKEN, USART\_CTRL2.LINMEN, USART\_CTRL3.SCMEN, USART\_CTRL3.IRDAMEN, these bits should be kept clear.

After the half-duplex mode is turned on, the TX pin and the RX pin are internally connected, and the RX pin is no longer used. When there is no data to be transmitted, TX is always released. Therefore, when not driven by the USART, the TX pin must be configured as a floating input or an open-drain output high.

### 18.4.12 Serial IrDA Infrared Encoding/Decoding Mode

USART supports the IrDA (Infrared Data Association).

Through the USART\_CTRL3.IRDAMEN bit, you can choose whether to enable the infrared mode. When using the infrared function, USART\_CTRL2.CLKEN, USART\_CTRL2.STPB[1:0], USART\_CTRL2.LINMEN, USART\_CTRL3.HDMEN, USART\_CTRL3.SCMEN, these bits should be kept clear.

Through the USART\_CTRL3.IRDALP bit, IrDA can be used to select normal mode or low power mode.

#### 18.4.12.1 IrDA normal mode

When USART\_CTRL3.IRDALP=0, USART device enters IrDA normal mode.

IrDA is a half-duplex communication protocol, so there should be a minimum delay of 10ms between transmitting and receiving. that uses a inverted return-to-zero modulation scheme (RZI), which uses an infrared light pulse to represent a logic '0', and the pulse width is specified as 3/16 of a bit period in normal mode, as shown in the Figure 18-19.USART only supports up to 115200bps .

The USART transmits data to the SIR encoder, and the bit stream output by the USART will be modulated. A modulated stream of pulses is sent from the infrared transmitter and then received by the infrared receiver. The SIR receiver decoder demodulates it and outputs the data to the USART.

The transmit encoder output has opposite polarity to the decoder input. When idle, SIR transmit is low, while SIR receive is high. The high pulse sent by SIR is '0' and the low level is '1', while SIR reception is the opposite.

If the USART is transmitting data to the IrDA transmit encoder, then the IrDA receive decoder will ignore any data on the IrDA receive line. If the USART is receiving data sent from the SIR receiver decoder, the data sent by the USART to the IrDA transmitter encoder will not be encoded.

Pulse width is programmable. The IrDA specification requires pulses to be wider than 1.41us. For pulse widths less than 2 cycles, the receiver will filter them out. PSCV is the prescaler value programmed in the USART\_GTP register.

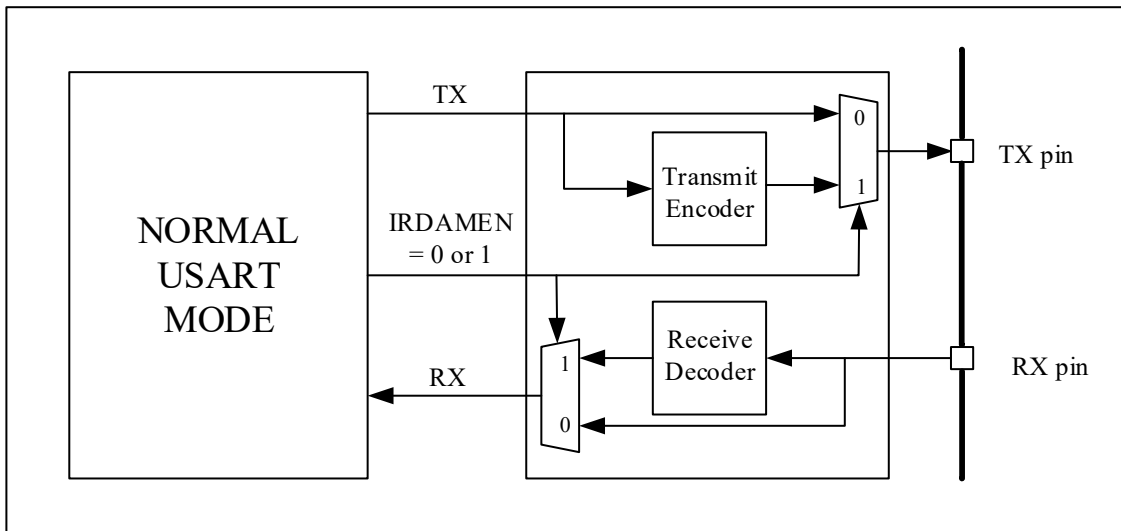
**18.4.12.2 IrDA low power mode**

When USART\_CTRL3.IRDALP=1, USART device enters IrDA low power mode.

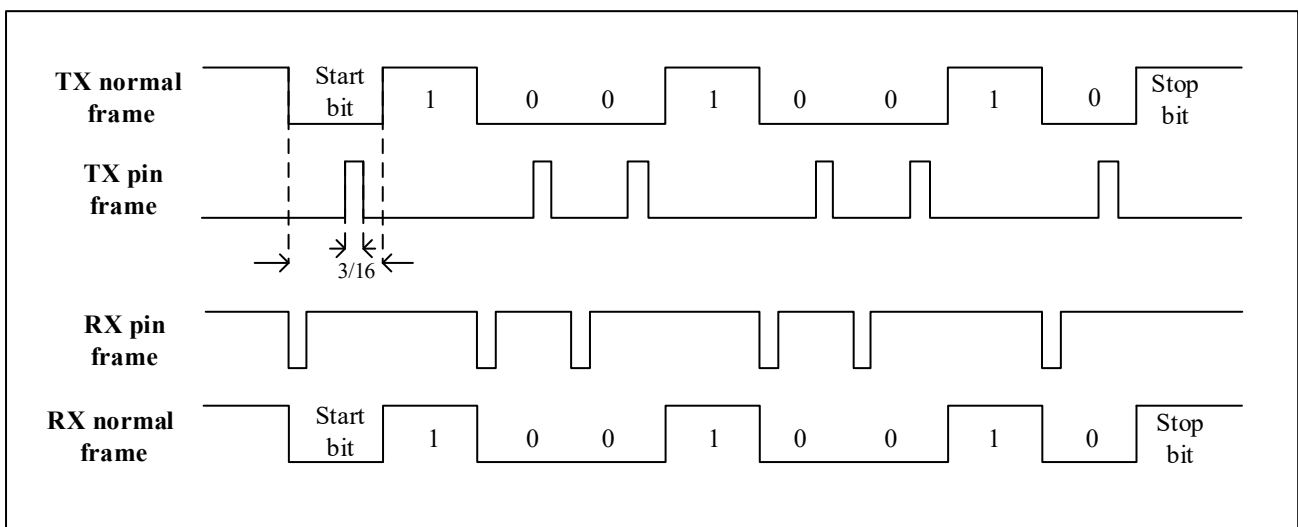
For the transmitter, when in low power mode, the pulse width is 3 times the low power baud rate, which is a minimum of 1.42MHz. Typically this value is 1.8432MHz (1.42 MHz < PSC < 2.12 MHz).

For the receiver, the requirement for a valid signal is that the duration of the low level signal must be greater than 2 cycles of the IrDA low power baud rate clock.

**Figure 18-18 IrDA Block Diagram**



**Figure 18-19 IrDA Data Modulation (3/16)-Normal Mode**





### 18.4.13 LIN Mode

USART supports the ability of a LIN (Local Interconnection Network) master to transmit a synchronization break frame and the ability of a LIN slave to detect a break frame. LIN mode can be enabled by configuring the USART\_CTRL2.LINMEN bit.

*Note: When using LIN mode, USART\_CTRL2.STPB[1:0], USART\_CTRL2.CLKEN, USART\_CTRL3.SCMEN, USART\_CTRL3.HDMEN, USART\_CTRL3.IRDAMEN, these bits should be kept clear.*

#### 18.4.13.1 LIN transmission

When data is sent in LIN mode, the length of the data bits sent can only be 8 bits. By setting USART\_CTRL1.SDBRK, a 13-bit '0' will be sent as the break frame, and insert a stop bit.

#### 18.4.13.2 LIN reception

Whether the bus is idle or during the transmission of a data frame, as long as the break frame appears, it can be detected. The break frame detection is independent of the USART receiver.

By configuring the USART\_CTRL2.LINBDL bit, the break frame detection low level can be set to either 10 bits or 11 bits.

After the receiver detects the start bit, the circuit samples each subsequent bit at the 8th, 9th, and 10th oversampling clock points of each bit. When 10 or 11 consecutive bits are detected as '0' and followed by a delimiter, it means that a LIN break frame is detected, and USART\_STS.LINBDF is set. Before confirming the break frame, the delimiter must be detected, indicating that the RX line has returned to the idle state (high level). If the USART\_CTRL2.LINBDIEN bit is set to 1 at this time, an interrupt will be triggered. If a '1' is sampled before the 10th or 11th sample point, the current break frame detection is canceled and the start bit is searched again.

Figure 18-20 Break Detection in LIN Mode (11-bit Break Length, The LINBDL Bit Is Set)

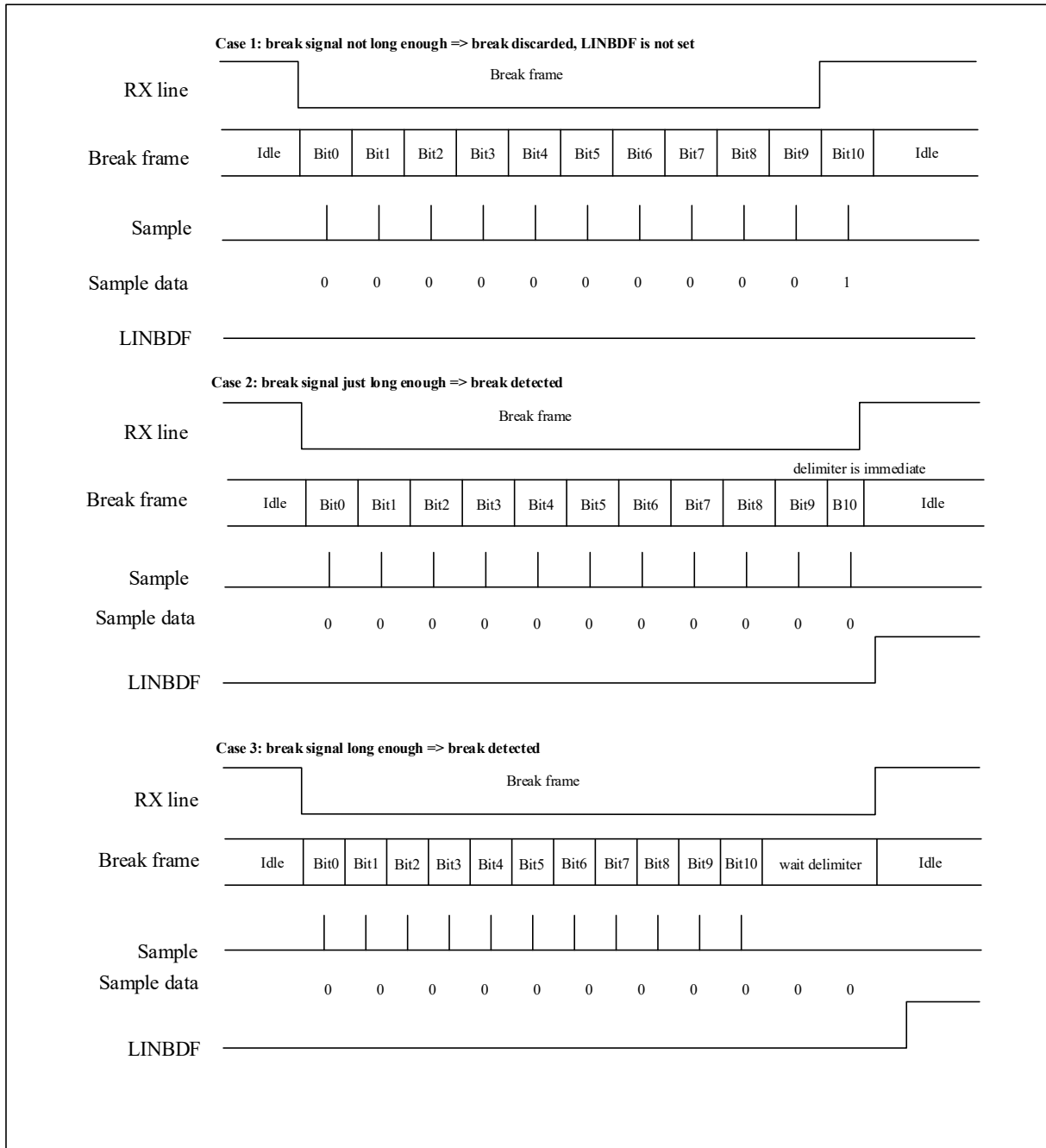
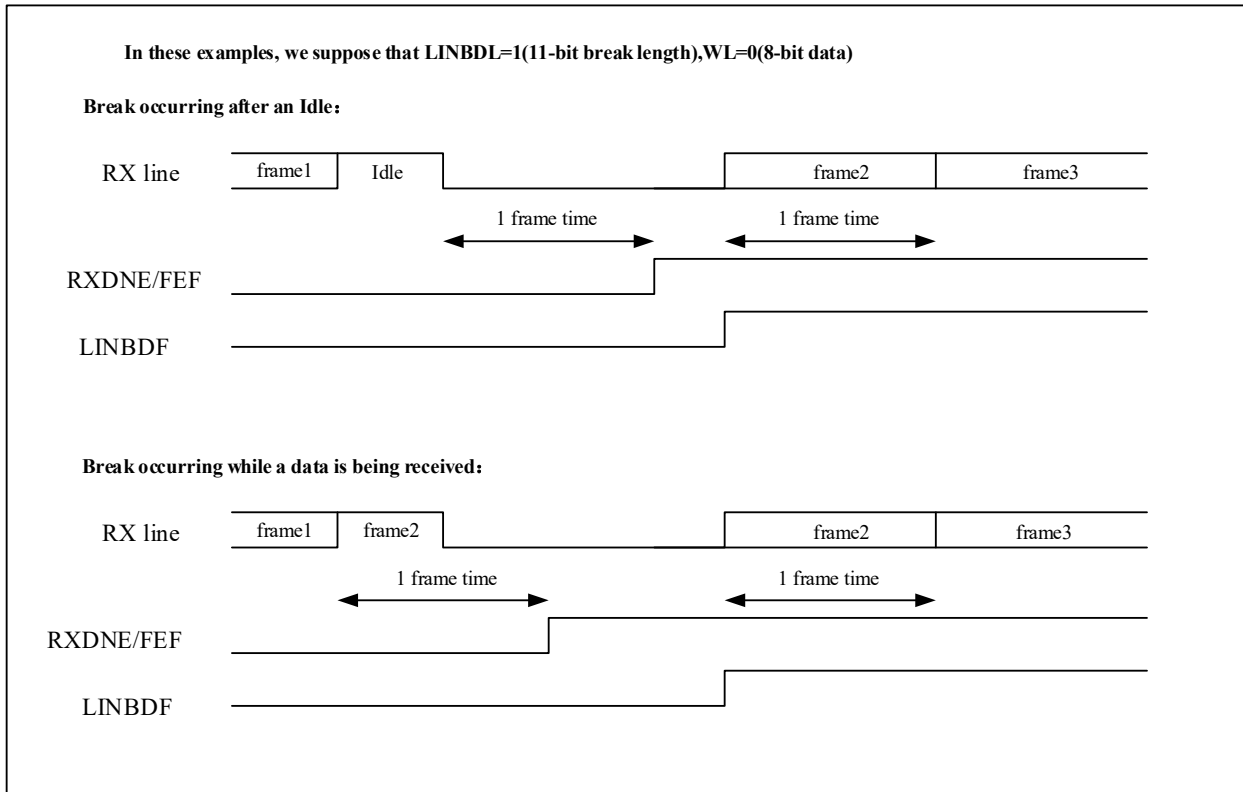


Figure 18-21 Break Detection and Framing Error Detection in LIN Mode



### 18.4.14 Smartcard Mode (ISO7816)

USART supports Smartcard protocol. The Smartcard interface supports the asynchronous Smartcard protocol defined in the ISO7816-3 standard.

Through the USART\_CTRL3. SCMEN bit, you can choose whether to enable Smartcard mode. When using Smartcard mode, USART\_CTRL2. LINMEN, USART\_CTRL3. HDMEN, USART\_CTRL3. IRDAMEN, these bits should be kept clear.

In Smartcard mode, the USART can provide a clock through the CK pin. The system clock is divided by the prescaler register to provide the clock to the Smartcard. The CK frequency can be from  $f_{CK}/2$  to  $f_{CK}/62$ , where  $f_{CK}$  is the peripheral input clock.

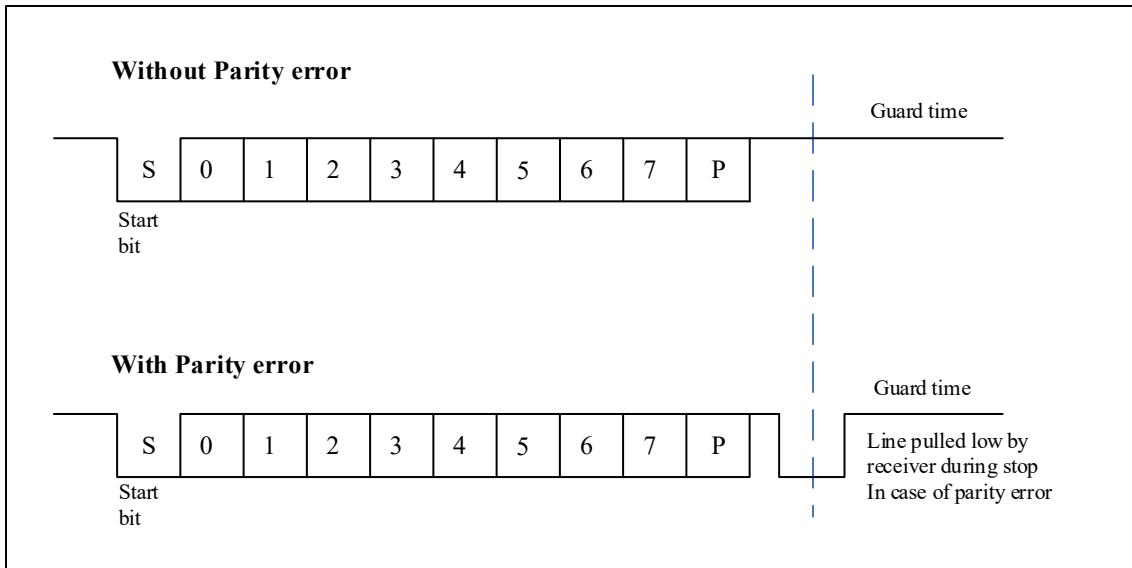
In Smartcard mode, 0.5 and 1.5 stop bits can be used when receiving data, and only 1.5 stop bits can be used when transmitting data. Therefore, it is recommended to use 1.5 stop bits for both transmission and reception to avoid frequent switching between configurations.

In Smartcard mode, the data bits should be configured as 8 bits, and the parity bit should be configured.

When the receiver detects a parity error, it pulls the data line low for one bit period after the stop bit as a NACK signal (when USART\_CTRL3.SCNACK bit is set to 1), while a frame error is generated at the transmitter end (with a 1.5-bit stop bit). When the transmitter receives a NACK signal (framing error) from the receiver, it does not treat the NACK as a start bit (according to the ISO protocol, the duration of the received NACK can be 1 or 2 baud clock cycles).

The example given in the following figure illustrates the signal on the data line with and without parity errors.

**Figure 18-22 ISO7816-3 Asynchronous Protocol**

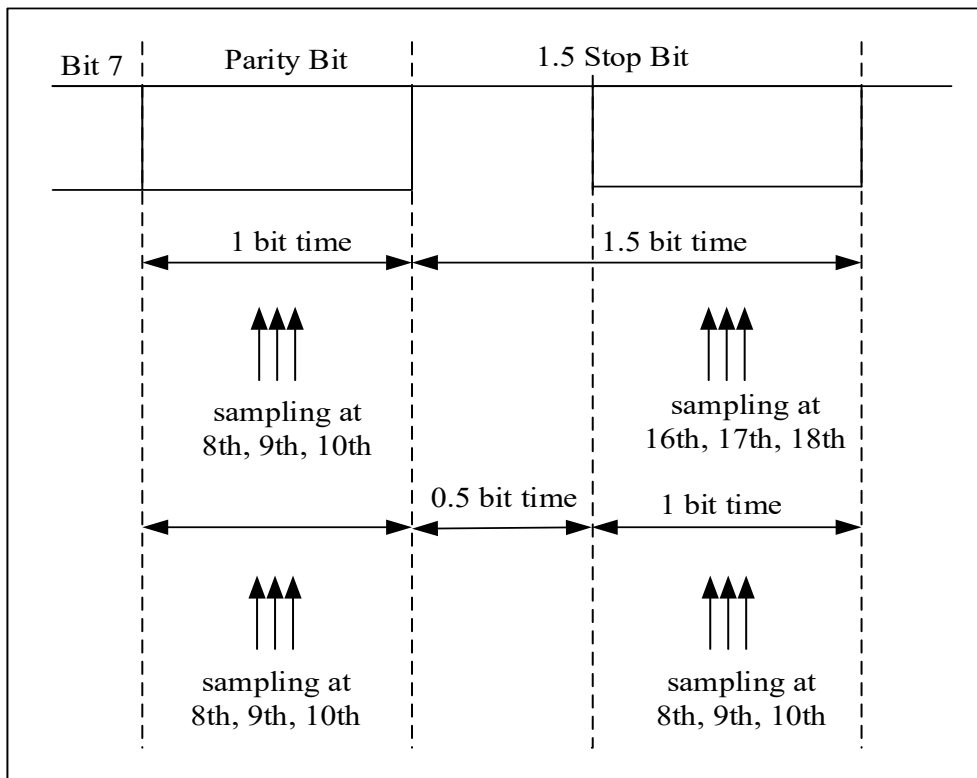


In Smartcard mode, break frames are not supported. If a break frame is received, it is treated as a data frame with a frame error, represented as 00h. In normal operation mode, data will be shifted out of the transmit shift register on the next baud clock. In the Smartcard mode, transmission is delayed by a minimum of 1/2 baud clock than normal operation.

In normal operation mode, when a data frame is sent and USART\_STS.TXDE=1, USART\_STS.TXC is set to 1. In Smartcard mode, the USART\_STS.TXC bit is only set to 1 when the data is sent and the guard time reaches the preset value (USART\_GTP.GTV[7:0]), and clearing the USART\_STS.TXC flag is not affected by the Smartcard mode.

The following figure details how USART samples NACK signals.

Figure 18-23 Use 1.5 Stop Bits to Detect Parity Errors



## 18.5 Interrupt Request

The various interrupt events of USART are logical OR relations, if the corresponding enable control bit is set, these events can trigger their own interrupts, but only one interrupt request can be triggered at the same time.

Table 18-8 USART Interrupt Request

| Interrupt Function     | Interrupt Event                      | Event Flag | Enable Bit |
|------------------------|--------------------------------------|------------|------------|
| USART global interrupt | Transmission data register is empty. | TXDE       | TXDEIEN    |
|                        | CTS flag                             | CTSF       | CTSIEN     |
|                        | Transmission complete                | TXC        | TXCIEN     |
|                        | Receive data ready to be read        | RXDNE      | RXDNEIEN   |
|                        | Data overrun error detected.         | ORERR      |            |
|                        | Idle line detected                   | IDLEF      | IDLEIEN    |
|                        | Parity error                         | PEF        | PEIEN      |
|                        | Disconnect flag                      | LINBDF     | LINBDIEN   |

|  |  |              |                       |
|--|--|--------------|-----------------------|
|  | Noise, overrun error and framing error in multi-buffer communication | NEF/OREF/FEF | ERRIEN <sup>(1)</sup> |
|--|--|--------------|-----------------------|

Note:

<sup>(1)</sup>This flag bit is used only when DMA is used to receive data(USART\_CTRL3.DMARXEN=1).

## 18.6 Mode Support

**Table 18-9 USART Mode Setting <sup>(1)</sup>**

| Communication Mode           | USART1 | USART2 |
|------------------------------|--------|--------|
| Asynchronous mode            | Y      | Y      |
| Hardware flow control mode   | Y      | Y      |
| DMA communication mode       | Y      | Y      |
| Multiprocessor               | Y      | Y      |
| Synchronous mode             | Y      | Y      |
| Smartcard mode               | Y      | Y      |
| Single-wire half duplex mode | Y      | Y      |
| IrDA infrared mode           | Y      | Y      |
| LIN                          | Y      | Y      |

Note:

<sup>(1)</sup>Y = support this mode, N = do not support this mode

## 18.7 USART Register

### 18.7.1 USART Register Overview

**Table 18-10 USART Register Overview**

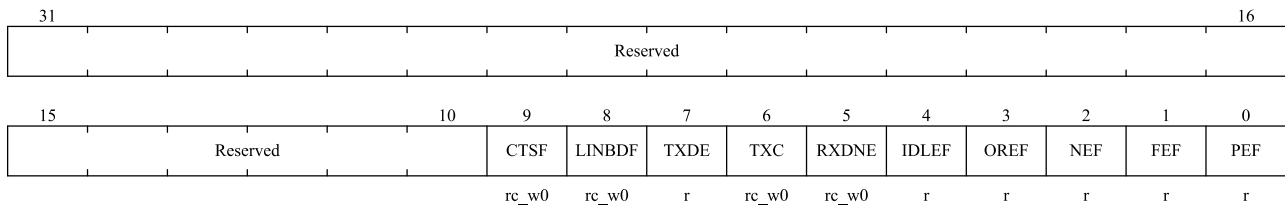
| Offset | Register    | 31       | 30 | 29 | 28 | 27 | 26 | 25 | 24 | 23 | 22 | 21 | 20 | 19 | 18 | 17 | 16 | 15 | 14 | 13 | 12 | 11 | 10 | 9         | 8    | 7    | 6   | 5     | 4     | 3    | 2   | 1   | 0   |   |   |   |   |   |   |   |   |   |   |   |   |   |   |   |   |   |   |   |   |   |
|--------|-------------|----------|----|----|----|----|----|----|----|----|----|----|----|----|----|----|----|----|----|----|----|----|----|-----------|------|------|-----|-------|-------|------|-----|-----|-----|---|---|---|---|---|---|---|---|---|---|---|---|---|---|---|---|---|---|---|---|---|
| 000h   | USART_STS   | Reserved |    |    |    |    |    |    |    |    |    |    |    |    |    |    |    |    |    |    |    |    |    | CTS       | LNBD | TXDE | TXC | RXDNE | IDLEF | OREF | NEF | FEF | PEF |   |   |   |   |   |   |   |   |   |   |   |   |   |   |   |   |   |   |   |   |   |
|        | Reset Value |          |    |    |    |    |    |    |    |    |    |    |    |    |    |    |    |    |    |    |    |    |    | 0         | 0    | 1    | 1   | 0     | 0     | 0    | 0   | 0   | 0   | 0 | 0 | 0 | 0 | 0 | 0 | 0 | 0 | 0 | 0 | 0 | 0 | 0 | 0 | 0 | 0 | 0 | 0 | 0 | 0 | 0 |
| 004h   | USART_DAT   | Reserved |    |    |    |    |    |    |    |    |    |    |    |    |    |    |    |    |    |    |    |    |    | DATV[8:0] |      |      |     |       |       |      |     |     |     |   |   |   |   |   |   |   |   |   |   |   |   |   |   |   |   |   |   |   |   |   |
|        | Reset Value |          |    |    |    |    |    |    |    |    |    |    |    |    |    |    |    |    |    |    |    |    |    | 0         | 0    | 0    | 0   | 0     | 0     | 0    | 0   | 0   | 0   | 0 | 0 | 0 | 0 | 0 | 0 | 0 | 0 | 0 | 0 | 0 | 0 | 0 | 0 | 0 | 0 | 0 | 0 | 0 | 0 | 0 |

| Offset | Register    | 31       | 30 | 29 | 28 | 27 | 26 | 25 | 24 | 23 | 22 | 21 | 20 | 19 | 18 | 17                | 16         | 15      | 14      | 13      | 12     | 11      | 10        | 9        | 8       | 7                 | 6         | 5     | 4     | 3 | 2 | 1 | 0 |
|--------|-------------|----------|----|----|----|----|----|----|----|----|----|----|----|----|----|-------------------|------------|---------|---------|---------|--------|---------|-----------|----------|---------|-------------------|-----------|-------|-------|---|---|---|---|
| 008h   | USART_BRCF  | Reserved |    |    |    |    |    |    |    |    |    |    |    |    |    | DIV_Integer[11:0] |            |         |         |         |        |         |           |          |         | DIV_Decimal [3:0] |           |       |       |   |   |   |   |
|        | Reset Value | 0        |    |    |    |    |    |    |    |    |    |    |    |    |    | 0                 |            |         |         |         |        |         |           |          |         | 0                 |           |       |       |   |   |   |   |
| 00Ch   | USART_CTRL1 | Reserved |    |    |    |    |    |    |    |    |    |    |    |    |    | UEN               | WL         | WUM     | PCEN    | PSEL    | PEIEN  | TXDEIEN | TXCIEN    | RXDNEIEN | IDLEIEN | TXEN              | RXEN      | RCVWU | SDBRK |   |   |   |   |
|        | Reset Value | 0        |    |    |    |    |    |    |    |    |    |    |    |    |    | 0                 | 0          | 0       | 0       | 0       | 0      | 0       | 0         | 0        | 0       | 0                 | 0         | 0     |       |   |   |   |   |
| 010h   | USART_CTRL2 | Reserved |    |    |    |    |    |    |    |    |    |    |    |    |    | LINMEN            | STPB [1:0] |         | CLKEN   | CLKPOL  | CLKPHA | LBCLK   | Reserved  | LINBDIEN | LINBDL  | Reserved          | ADDR[3:0] |       |       |   |   |   |   |
|        | Reset Value | 0        |    |    |    |    |    |    |    |    |    |    |    |    |    | 0                 | 0          | 0       | 0       | 0       | 0      | 0       | 0         | 0        | 0       | 0                 | 0         | 0     |       |   |   |   |   |
| 014h   | USART_CTRL3 | Reserved |    |    |    |    |    |    |    |    |    |    |    |    |    | CTSIEIEN          | CTSEIEN    | RTSEIEN | DMATXEN | DMARXEN | SCMIEN | SCNACK  | HDMEN     | IRDALP   | IRDAIEN | ERRIEN            |           |       |       |   |   |   |   |
|        | Reset Value | 0        |    |    |    |    |    |    |    |    |    |    |    |    |    | 0                 | 0          | 0       | 0       | 0       | 0      | 0       | 0         | 0        | 0       | 0                 |           |       |       |   |   |   |   |
| 018h   | USART_GTP   | Reserved |    |    |    |    |    |    |    |    |    |    |    |    |    | GTV[7:0]          |            |         |         |         |        |         | PSCV[7:0] |          |         |                   |           |       |       |   |   |   |   |
|        | Reset Value | 0        |    |    |    |    |    |    |    |    |    |    |    |    |    | 0                 |            |         |         |         |        |         | 0         |          |         |                   |           |       |       |   |   |   |   |

### 18.7.2 USART Status Register (USART\_STS)

Address offset : 0x00

Reset value : 0x0000 00C0



| Bit Field | Name     | Description   |
|-----------|----------|---|
| 31:10     | Reserved | Reserved, the reset value must be maintained  |
| 9         | CTSF     | CTS flag<br>If USART_CTRL3.CTSEIEN bit is set, this bit is set by hardware when the nCTS input changes. If USART_CTRL3.CTSIEIEN bit is set, an interrupt will be generated.<br>This bit is cleared by software.<br>0:nCTS status line has not changed.<br>1:nCTS status line changes. |
| 8         | LINBDF   | LIN break detection flag.<br>If USART_CTRL2.LINMEN bit is set, this bit is set by hardware when LIN disconnection is detected. If USART_CTRL2.LINBDIEN bit is set, an interrupt will be generated.<br>This bit is cleared by software.<br>0: LIN break character not detected.        |

| Bit Field | Name  | Description  |
|-----------|-------|--|
|           |       | 1: LIN break character detected.   |
| 7         | TXDE  | <p>The Transmit data register empty.</p> <p>Set to 1 after power-on reset or data to be sent has been sent to the shift register. Setting USART_CTRL1.TXDEIEN will generate an interrupt.</p> <p>This bit is cleared to 0 when the software writes the data to be sent into USART_DAT.</p> <p>0: Transmit data buffer is not empty.</p> <p>1: The transmitting data buffer is empty.</p>   |
| 6         | TXC   | <p>Transmission complete.</p> <p>This bit is set to 1 after power-on reset. If USART_STS.TXDE is set, this bit is set when the current data transmission is completed.</p> <p>Setting USART_CTRL1.TXCIEN bit will generate an interrupt.</p> <p>This bit is cleared by software.</p> <p>0: Transmitting did not complete.</p> <p>1: Transmit completed.</p>  |
| 5         | RXDNE | <p>The Read data register not empty.</p> <p>This bit is set when the read data buffer receives data from the shift register. When USART_CTRL1.RXDNEIEN bit is set, an interrupt will be generated.</p> <p>Software can clear this bit by writing 0 to it or reading the USART_DAT register.</p> <p>0: The read data buffer is empty.</p> <p>1: The read data buffer is not empty.</p>  |
| 4         | IDLEF | <p>IDLE line detected flag.</p> <p>Within one frame time, the idle state is detected at the RX pin, and this bit is set to 1. When USART_CTRL1.IDLEIEN bit is set, an interrupt will be generated.</p> <p>The software can clear this bit by reading USART_STS first and then reading USART_DAT.</p> <p>0: No idle frame detected.</p> <p>1: idle frame detected.</p> <p><i>Note: IDLEF bit will not be set high again until USART_STS.RXDNE bit is set (that is, an idle line is detected again).</i></p> |
| 3         | OREF  | <p>Overrun error</p> <p>With RXDNE set, this bit is set if the USART_DAT register receives data from the shift register. When USART_CTRL3.ERRIEN bit is set, an interrupt will be generated.</p> <p>The software can clear this bit by reading USART_STS first and then reading USART_DAT.</p> <p>0: No overrun error was detected.</p> <p>1: Overflow error detected.</p>   |
| 2         | NEF   | <p>Noise error flag.</p> <p>When noise is detected in the received frame, this bit is set by hardware. It is cleared by the software sequence (read first USART_STS, read USART_DAT again).</p> <p>0: No noise error detected.</p> <p>1: Noise error detected.</p>   |

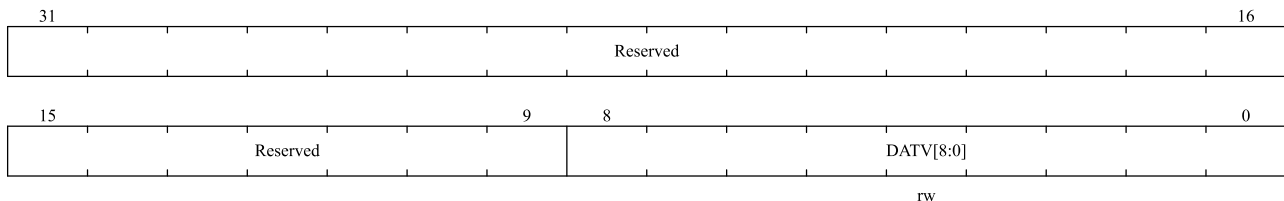


| Bit Field | Name | Description  |
|-----------|------|--|
|           |      | <i>Note: this bit will not generate an interrupt because it appears with USART_STS.RXDNE, and the hardware will generate an interrupt when setting the USART_STS.RXDNE flag. In the multi-buffer communication mode, if the USART_CTRL3.ERRIEN bit is set, an interrupt will be generated when the NEF flag is set.</i>  |
| 1         | FEF  | <p>Framing error.</p> <p>When the data is not synchronized or a large amount of noise is detected, and the stop bit is not received and recognized at the expected time, it will be judged that a framing error has been detected, and this bit will be set to 1. First read USART_STS, then read USART_DAT can cleared this bit.</p> <p>0: No framing errors were detected.</p> <p>1: A framing error or a Break Character is detected.</p> <p><i>Note: this bit will not generate an interrupt because it appears with USART_STS.RXDNE, and the hardware will generate an interrupt when setting the USART_STS.RXDNE flag. If the currently transmitted data has both framing errors and overload errors, the hardware will continue to transmit the data and only set the USART_STS.OREF flag bit.</i></p> <p><i>In the multi-buffer communication mode, if the USART_CTRL3.ERRIEN bit is set, an interrupt will be generated when the FEF flag is set.</i></p> |
| 0         | PEF  | <p>Parity error.</p> <p>This bit is set when the parity bit of the received data frame is different from the expected check value.</p> <p>The software can clear this bit by reading USART_STS first and then reading USART_DAT.</p> <p>0: No parity error was detected.</p> <p>1: Parity error detected.</p>  |

### 18.7.3 USART Data Register (USART\_DAT)

Address offset : 0x04

Reset value : undefined (uncertain value)



| Bit Field | Name     | Description                                  |
|-----------|----------|--|
| 31:9      | Reserved | Reserved, the reset value must be maintained |

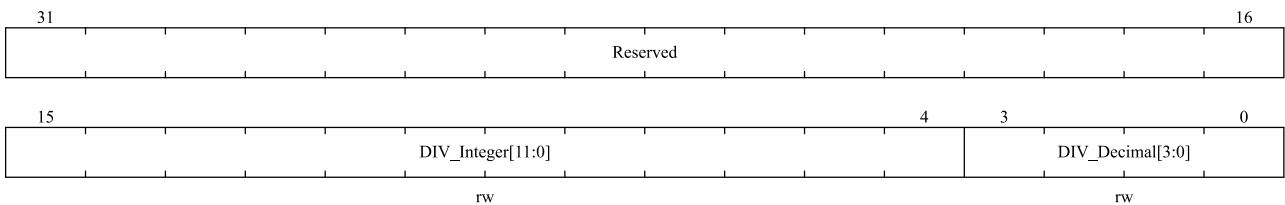
| Bit Field | Name      | Description   |
|-----------|-----------|---|
| 8:0       | DATV[8:0] | Data value<br>Contains the data sent or received; Software can change the transmitted data by writing these bits, or read the values of these bits to obtain the received data.<br>If parity is enabled, when the transmitted data is written into the register, the highest bit of the data (the 7th or 8th bit depends on USART_CTRL1.WL bit) will be replaced by the parity bit. |

### 18.7.4 USART Baud Rate Register (USART\_BRCF)

Address offset : 0x08

Reset value : 0x0000 0000

*Note: When USART\_CTRL1.UEN=1, this register cannot be written; The baud counter stops counting if USART\_CTRL1.TXEN or USART\_CTRL1.RXEN are disabled respectively.*

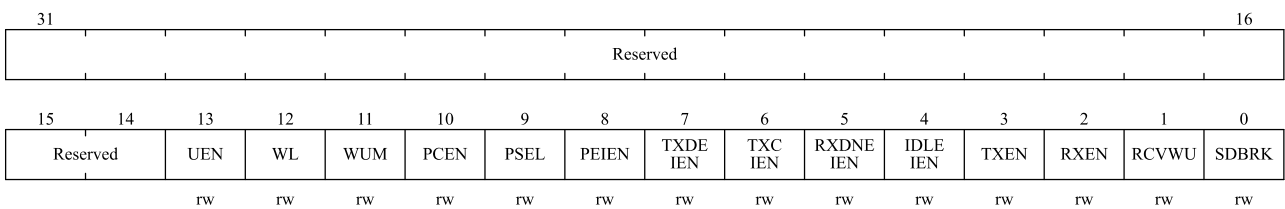


| Bit Field | Name               | Description                                  |
|-----------|--------------------|--|
| 31:16     | Reserved           | Reserved, the reset value must be maintained |
| 15:4      | DIV_Integer [11:0] | Integer part of baud rate divider.           |
| 3:0       | DIV_Decimal[3:0]   | Fractional part of baud rate divider.        |

### 18.7.5 USART Control Register 1 Register (USART\_CTRL1)

Address offset : 0x0C

Reset value : 0x0000 0000



| Bit Field | Name     | Description  |
|-----------|----------|--|
| 31:14     | Reserved | Reserved, the reset value must be maintained   |
| 13        | UEN      | USART enable<br>When this bit is cleared, the divider and output of USART stop operating after the current byte transmission is completed to reduce power consumption. Software can set or clear this bit.<br>0:USART is disabled. |

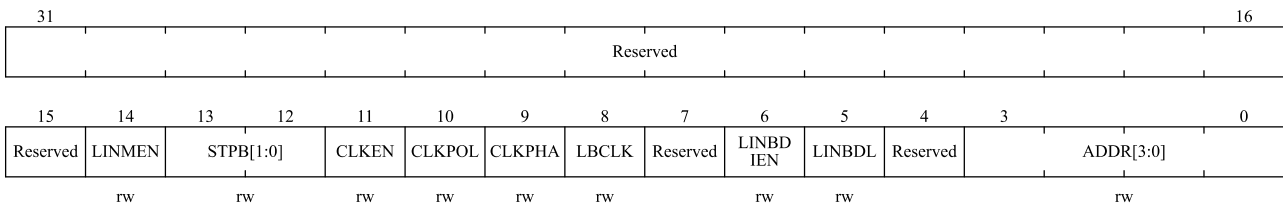
| Bit Field | Name     | Description  |
|-----------|----------|--|
|           |          | 1:USART is enabled.  |
| 12        | WL       | Word length.<br>0:8 data bits.<br>1:9 data bits.<br><i>Note: If data is in transfer, this bit cannot be configured.</i>  |
| 11        | WUM      | Wake up mode from mute mode.<br>0: Idle frame wake up.<br>1: Address identifier wake up.   |
| 10        | PCEN     | Parity control enable<br>0: Parity control is disabled.<br>1: Parity control is enabled.   |
| 9         | PSEL     | Parity selection.<br>0: even check.<br>1: odd check.   |
| 8         | PEIEN    | PE interrupt enable<br>If this bit is set to 1, an interrupt is generated when USART_STS.PEF bit is set.<br>0: Parity error interrupt is disabled.<br>1: Parity error interrupt is enabled.  |
| 7         | TXDEIEN  | TXDE interrupt enable<br>If this bit is set to 1, an interrupt is generated when USART_STS.TXDE bit is set.<br>0: Transmit buffer empty interrupt is disabled.<br>1: Transmit buffer empty interrupt is enabled.   |
| 6         | TXCIEN   | Transmit complete interrupt enable.<br>If this bit is set to 1, an interrupt is generated when USART_STS.TXC is set.<br>0: Transmission completion interrupt is disabled.<br>1: Transmission completion interrupt is enabled.  |
| 5         | RXDNEIEN | RXDNE interrupt enable<br>If this bit is set to 1, an interrupt is generated when USART_STS.RXDNE or USART_STS.OREF is set.<br>0: Data buffer non-empty interrupt o and overrun error interrupt are disabled.<br>1: Data buffer non-empty interrupt o and overrun error interrupt are enabled. |
| 4         | IDLEIEN  | IDLE interrupt enable.<br>If this bit is set to 1, an interrupt is generated when USART_STS.IDLEF is set.<br>0:IDLE line detection interrupt is disabled.<br>1: IDLE line detection interrupt is enabled.  |
| 3         | TXEN     | Transmitter enable.<br>0: The transmitter is disabled.<br>1: the transmitter is enabled.   |
| 2         | RXEN     | Receiver enable<br>0: The receiver is disabled.<br>1: the receiver is enabled.   |

| Bit Field | Name  | Description  |
|-----------|-------|--|
| 1         | RCVWU | The receiver wakes up<br>Software can set this bit to 1 to make USART enter mute mode, and clear this bit to 0 to wake up USART.<br>In idle frame wake-up mode (USART_CTRL1.WUM=0), this bit is cleared by hardware when an idle frame is detected. In address wake-up mode (USART_CTRL1.WUM=1), when an address matching frame is received, this bit is cleared by hardware. Or when an address mismatch frame is received, it is set to 1 by hardware.<br>0: The receiver is in normal operation mode.<br>1: The receiver is in mute mode. |
| 0         | SDBRK | Transmit Break Character.<br>The software transmits a break character by setting this bit to 1.<br>This bit is cleared by hardware during stop bit of the break frame transmission.<br>0: No break character was sent.<br>1: Transmit a break character.   |

**18.7.6 USART Control Register 2 Register (USART\_CTRL2)**

Address offset : 0x10

Reset value : 0x0000 0000



| Bit Field | Name      | Description  |
|-----------|-----------|--|
| 31:15     | Reserved  | Reserved, the reset value must be maintained   |
| 14        | LINMEN    | LIN mode enable<br>0:LIN mode is disabled<br>1:LIN mode enabled  |
| 13:12     | STPB[1:0] | STOP bits.<br>00:1 stop bit.<br>01:0.5 stop bit.<br>10:2 stop bit.<br>11:1.5 stop bit.   |
| 11        | CLKEN     | Clock enable<br>0:CK pin is disabled<br>1:CK pin enabled   |
| 10        | CLKPOL    | Clock polarity.<br>This bit is used to set the polarity of CK pin in synchronous mode.<br>0: CK pin remains low when it is not transmitted to the outside. |

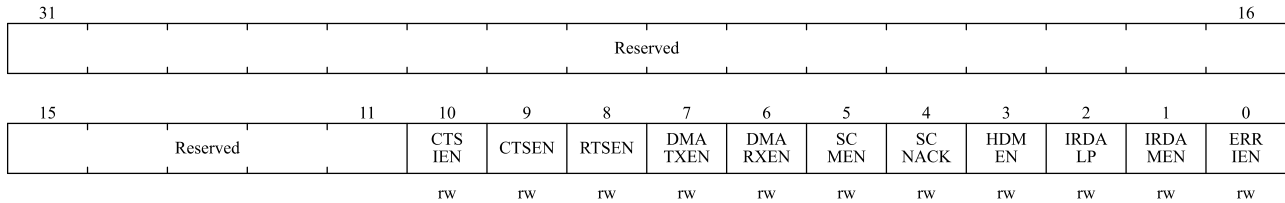
| Bit Field | Name      | Description   |
|-----------|-----------|---|
|           |           | 1: CK pin remains high when it is not sent to the outside.  |
| 9         | CLKPHA    | <p>Clock phase.</p> <p>This bit is used to set the phase of CK pin in synchronous mode.</p> <p>0: Sample the first data at the first clock edge.</p> <p>1: Sample the first data at the second clock edge.</p>  |
| 8         | LBCLK     | <p>The Last bit clock pulse.</p> <p>This bit is used to set whether the clock pulse corresponding to the last transmitted data byte (MSB) is output on CK pin in synchronous mode.</p> <p>0: The clock pulse of the last bit of data is not output from CK.</p> <p>1: The clock pulse of the last bit of data will be output from CK.</p>   |
| 7         | Reserved  | Reserved, the reset value must be maintained  |
| 6         | LINBDIEN  | <p>LIN break detection interrupt enable.</p> <p>If this bit is set to 1, an interrupt will be generated when USART_STS.LINBDF bit is set.</p> <p>0: Disconnect signal detection interrupt is disabled.</p> <p>1: Turn-off signal detection interrupt enabled</p>  |
| 5         | LINBDL    | <p>LIN break detection length.</p> <p>This bit is used to set the length of the break frame.</p> <p>0:10 bit break detection</p> <p>1:11 bit break detection</p> <p><i>Note: LINBDL can be used to control the detection length of Break Characters in LIN mode and other modes, and the detection length is the same as that in LIN mode.</i></p>  |
| 4         | Reserved  | Reserved, the reset value must be maintained  |
| 3:0       | ADDR[3:0] | <p>USART address.</p> <p>Used in the mute mode of multiprocessor communication, using address identification to wake up a USART device.</p> <p>In address wake-up mode (USART_CTRL1.WUM=1), if the lower four bits of the received data frame are not equal to the ADDR[3:0] value, USART will enter the mute mode; If the lower four bits of the received data frame are equal to the ADDR[3:0] value, USART will be awakened.</p> |

*Note: These three bits (USART\_CTRL2.CLKPOL, USART\_CTRL2.CLKPHA, USART\_CTRL2.LBCLK) cannot be overwritten after enabling transmission.*

### 18.7.7 USART Control Register 3 Register (USART\_CTRL3)

Address offset : 0x14

Reset value : 0x0000 0000



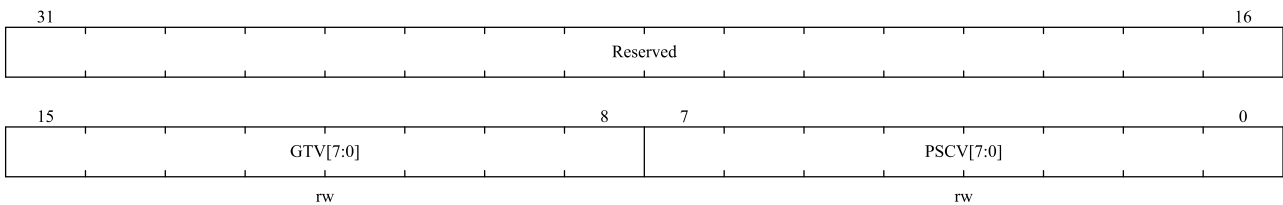
| Bit Field | Name     | Description  |
|-----------|----------|--|
| 31:11     | Reserved | Reserved, the reset value must be maintained   |
| 10        | CTSIEN   | CTS interrupt enable.<br>If this bit is set to 1, an interrupt will be generated when USART_STS.CTSF bit is set.<br>0:CTS interrupt is disabled.<br>1:CTS interrupt is enabled.  |
| 9         | CTSEN    | CTS enable.<br>This bit is used to enable the CTS hardware flow control function.<br>0:CTS hardware flow control is disabled.<br>1:CTS hardware flow control is enabled.   |
| 8         | RTSEN    | RTS enable.<br>This bit is used to enable RTS hardware flow control function.<br>0:RTS hardware flow control is disabled.<br>1:RTS hardware flow control is enabled.   |
| 7         | DMATXEN  | DMA transmitter enable.<br>0:DMA transmission mode is disabled.<br>1:DMA transmission mode is enabled.   |
| 6         | DMARXEN  | DMA receiver enable.<br>0:DMA receive mode is disabled.<br>1:DMA receive mode is enabled.  |
| 5         | SCMEN    | Smartcard mode enable.<br>This bit is used to enable Smartcard mode.<br>0: Smartcard mode is disabled.<br>1: Smartcard mode is enabled.  |
| 4         | SCNACK   | Smartcard NACK enable.<br>This bit is used for Smartcard mode to enable transmitting NACK when parity error occurs.<br>0: Do not send NACK when there is a parity error.<br>1: Send NACK when there is a parity error. |
| 3         | HDMEN    | Half-duplex mode enable.<br>This bit is used to enable half-duplex mode.<br>0: Half-duplex mode is disabled.<br>1: Half-duplex mode is enabled.  |
| 2         | IRDALP   | IrDA low-power mode.<br>This bit is used to select the low power consumption mode for IrDA mode.   |

| Bit Field | Name    | Description   |
|-----------|---------|---|
|           |         | 0: Normal mode.<br>1: Low power mode.   |
| 1         | IRDAMEN | IrDA mode enable.<br>0:IrDA is disabled.<br>1:IrDA is enabled.  |
| 0         | ERRIEN  | Error interrupt enable.<br>When DMA receive mode (USART_CTRL3.DMARXEN=1) is enabled, an interrupt will be generated when USART_STS.FEF, USART_STS. OREF or USART_STS. NEF bit is set.<br>0: Error interrupt is disabled.<br>1: Error interrupt enabled. |

**18.7.8 USART Guard Time and Prescaler Register (USART\_GTP)**

Address offset : 0x18

Reset value : 0x0000 0000



| Bit Field | Name      | Description  |
|-----------|-----------|--|
| 31:16     | Reserved  | Reserved, the reset value must be maintained   |
| 15:8      | GTV[7:0]  | Guard time value in Smartcard mode.<br>This bit field specifies the guard time in baud clock. In Smartcard mode, this function is required. The setting time of USART_STS.TXC flag is delayed by GTV[7:0] baud clock cycles.   |
| 7:0       | PSCV[7:0] | Prescaler value.<br>In IrDA low power consumption mode:<br>these bits are used to set the frequency division coefficient for dividing the peripheral clock (PCLK1/PCLK2) to generate low power consumption frequency.<br>00000000: reserved-do not write this value.<br>00000001: divide the source clock by 1.<br>...<br>11111111: divide the source clock by 255.<br>In IrDA normal mode:<br>PSCV can only be set to 00000001.<br>In Smartcard mode:<br>PSCV[4:0] is used to set the frequency division of Smartcard clock generated by peripheral clock (PCLK1/ PCLK2). |

| Bit Field | Name | Description   |
|-----------|------|---|
|           |      | Coefficient. The actual frequency division coefficient of is twice the set value of PSCV[4:0].<br>0000: reserved-do not write this value.<br>0001: Divide the source clock by 2.<br>0010: Divide the source clock by 4.<br>...<br>1111: Divide the source clock by 62.<br>In Smartcard mode, PSCV[7:5] is reserved. |



## 19 Low Power Universal Asynchronous Receiver Transmitter

### 19.1 Introduction

Low power universal asynchronous receiver transmitter (LPUART) is a low power, full duplex, asynchronous serial communication interface. The LPUART can be clocked by HSI, HSE, LSI, LSE, SYSCLK and PCLK1. When 32.768kHz LSE is selected as the clock source, the LPUART can operate in STOP low-power mode with a maximum communications up to 9600bps. LPUART supports receiving data wake-up. By configuring wake-up events, the CPU in STOP2 mode can be woken up.

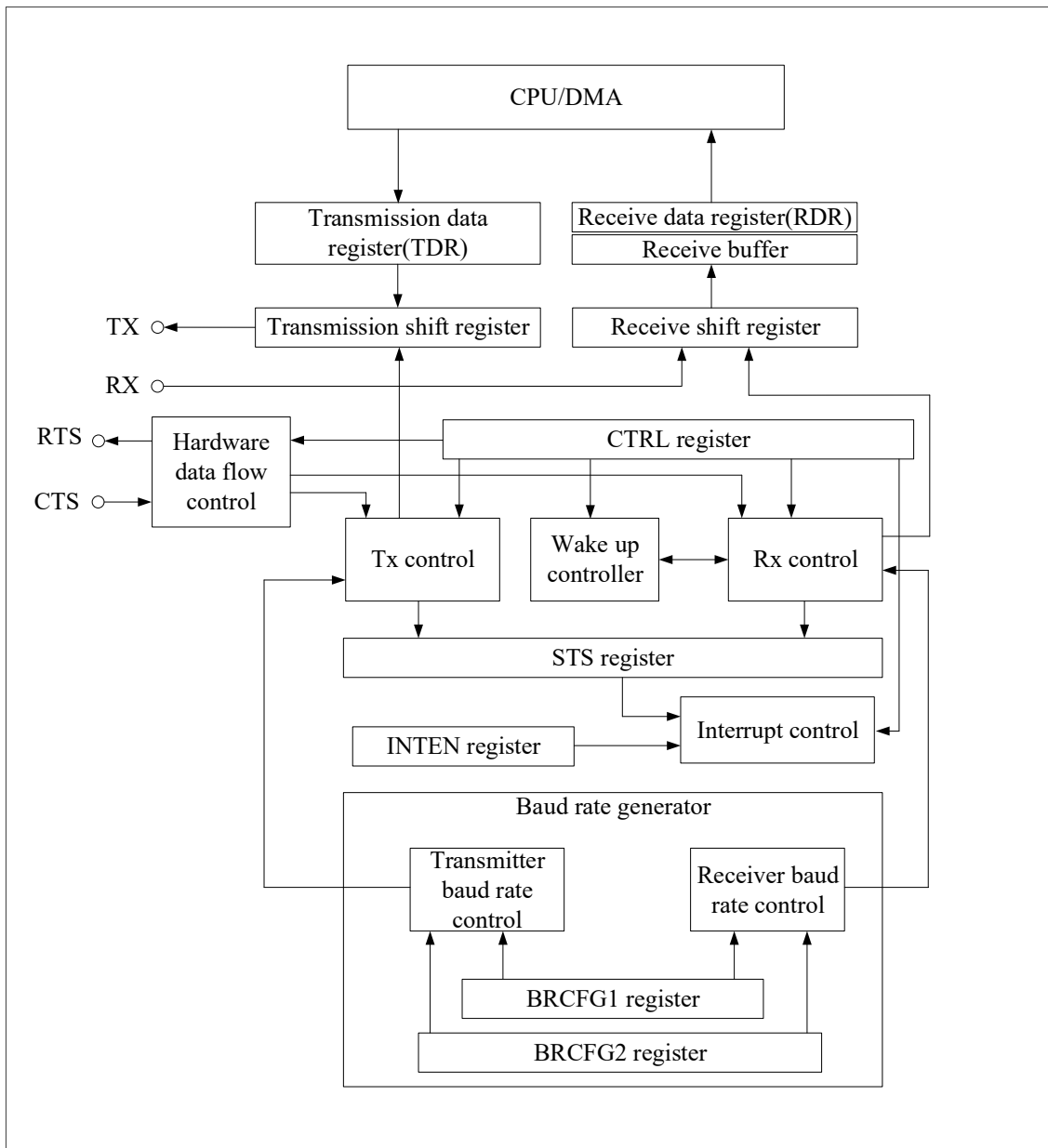
At the same time, when MCU operates in RUN mode, LPUART can also be used as a common asynchronous serial port. Users can switch the clock source to HSI, HSE, SYSCLK and PCLK1 to obtain higher communication speed.

### 19.2 Main Features

- Full duplex asynchronous communication
- Selectable clock source of HSI, HSE, LSI, LSE, SYSCLK, or PCLK1
- Fractional baud rate generator system: programmable baud rate shared by transmitting and receiving up to 1Mbits/s, baud rates from 300bps to 9600bps when using 32.768 kHz clock source (LSE)
- Fixed 8-bit data word length, 1 stop bit and optional 1 parity bit
- Supports DMA data transfer
- Supports hardware flow control
- Transfer detection flag: receive buffer full, receive buffer half full, receive buffer not empty, receive buffer overrun, transmission complete
- Parity control: odd and even parity selection, parity can be disabled
- Error detection flag: parity error, overrun error, noise error
- 32 byte receive buffer
- Baud rate error correction at low frequencies
- Configurable sampling method of 1 or 3 samples
- Noise detection
- Configurable flow control RTS threshold
- Supports for STOP mode wake-up, wake-up source can be configured
  - Start bit detection
  - Receive buffer non-empty detection
  - One configurable receive byte
  - One programmable 4-byte frame

### 19.3 Functional Block Diagram

Figure 19-1 LPUART Block Diagram



### 19.4 Function Description

As shown in Figure 19-1, bidirectional LPUART communication requires at least two pins: receiving data input (RX) and transmitting data output (TX).

**RX:** Serial data input. When the number of samples is 3, data and noise can be distinguished.

**TX:** Serial data output. When transmitting is enabled, the pin defaults to be high level.

The following pins are required in hardware flow control mode:

**CTS (Clear To Send):** When transmitter detects that CTS is valid (low level), the next data is transmitted.

**RTS (Request To Send):** When receiver is ready to receive new data, pull the RTS pin low.

LPUART has the following characteristics:

- The bus should be in an idle state when not transmitting or receiving
- One start bit
- One data word (8 bits) with the least significant bits first
- One stop bit, indicating the end of a data frame
- A status register (LPUART\_STS)
- Data register (LPUART\_DAT)
- Two baud rate configuration registers (LPUART\_BRCFG1 and LPUART\_BRCFG2) using fractional baud rate generators: 16-bit integer and 8-bit decimal representations

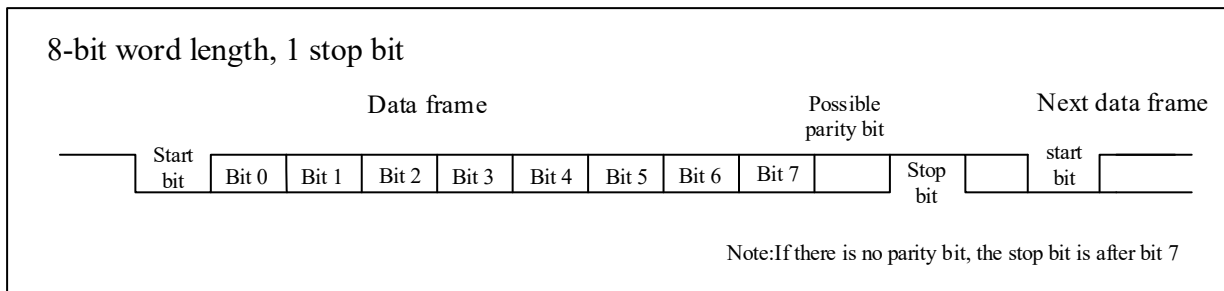
For specific definitions of each bit in the registers above, please refer to Section 19.6 of register description.

### 19.4.1 LPUART Frame Format

The LPUART data word length is fixed at 8 bits (refer to Figure 19-2). During the start bit, TX pin is at a low level and during the stop bit it is at a high level. The parity bit follows the data word when enabled.

Both transmitting and receiving are driven by two different baud clock generators. When the LPUART\_CTRL.TXEN of transmitter is set, the corresponding baud clock generator generates baud clock. When the start bit is received, the receiver's corresponding baud clock generator generates the clock.

**Figure 19-2 Frame Format**



*Note: in this chapter, unless special instruction, setting means that a register is set to state '1', and resetting or clearing means that a register is set to state '0'. Hardware or programs may set or clear a register. Please refer to this chapter for details.*

### 19.4.2 Transmitter

When the Transmit Enable bit (LPUART\_CTRL.TXEN) is set and there is data in the buffer, the transmitter transmits 8-bit data words. The data in the shift register is output on the TX pin.

#### 19.4.2.1 Transmission process

During an LPUART transmission, the least significant bit of the data is shifted out on TX pin. In this mode, the

LPUART\_DAT register contains a buffer between the internal bus and the transmitter shift register (refer to Figure 19-1).

Each character is preceded by a low level starting bit and followed by a 1-bit stop bit.

*Note: You cannot reset the LPUART\_CTRL.TXEN bit during data transmission, otherwise the data on the TX pin will be corrupted because the baud rate counter stops counting. The current data being transferred will be lost.*

The steps for LPUART to transmit data as follows:

1. Configure baud rate, parity check, DMA, flow control, etc.
2. Set the LPUART\_CTRL.TXEN bit to enable data transmission.
3. Write data to the LPUART\_DAT register.
4. Check if the LPUART\_STS.TXC flag is set, it means the transmission is over. If the flag is set, write 1 to the LPUART\_STS.TXC bit to clear the flag.
5. Check the LPUART\_STS.PEF bit to confirm whether the parity is wrong.
6. Otherwise, go to Step 3 and send the next data.

*Note: be sure to initialize the LPUART module before using the transmitter.*

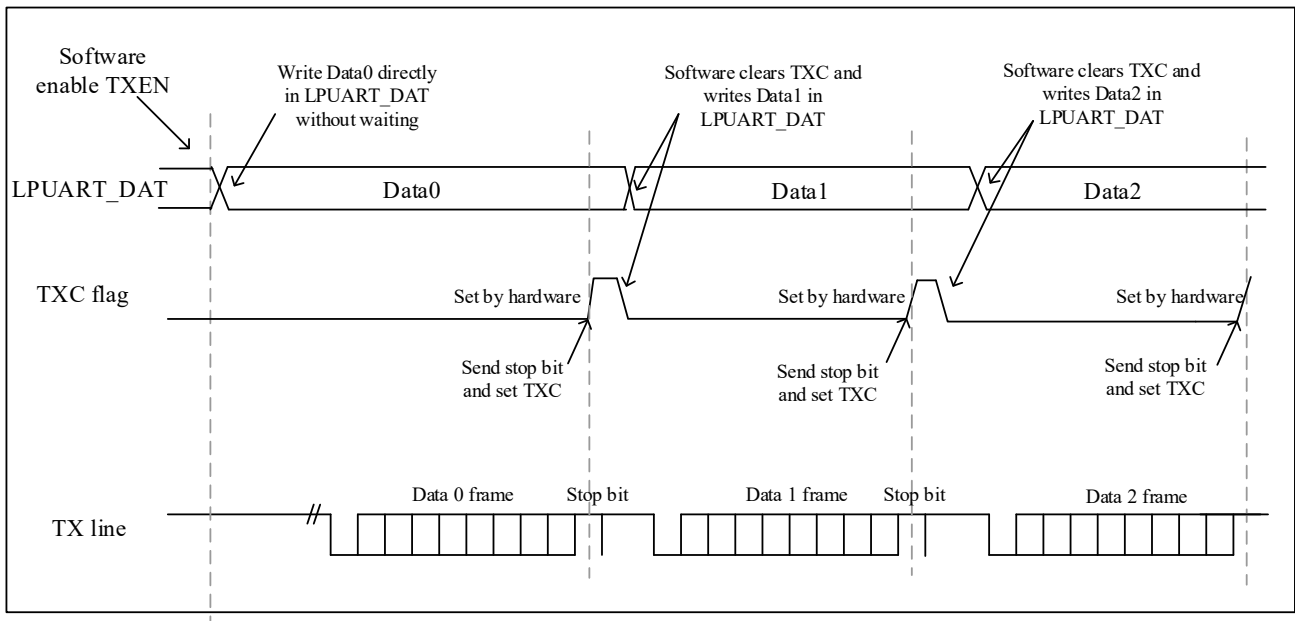
Initialization of LPUART proceeds as follows:

1. Set all flag bits in the LPUART\_STS register to clear the interrupt flag.
2. To enable the interrupt function, configure LPUART\_INTEN.
3. Set LPUART\_CTRL.FLUSH clear the RX buffer.

When transmit data:

- After configuring the baud rate and setting LPUART\_CTRL.TXEN, the CPU can write directly to the LPUART\_DAT register to send data.
- When a frame transmission is completed (after the stop bit is sent), the LPUART\_STS.TXC bit is set. If the LPUART\_INTEN.TXCIEN bit is set, an interrupt occurs immediately.
- After the last data byte is written to the LPUART\_DAT register, you must wait for LPUART\_STS.TXC=1 before shutting down the LPUART module or setting the microcontroller into low-power mode.

Figure 19-3 TXC Changes During Transmission



### 19.4.3 Receiver

#### 19.4.3.1 Start bit detection

If the LPUART\_CTRL.SMPCNT bit is 0, meaning the number of samples is 3, the start bit is considered valid if at least 2 out of the three samples are 0. Otherwise, it is considered invalid.

| Sampling Values | NF State | Received Bit Value | Start Bit Validity |
|-----------------|----------|--------------------|--------------------|
| 000             | 0        | 0                  | effective          |
| 001             | 1        | 0                  | effective          |
| 010             | 1        | 0                  | effective          |
| 011             | 1        | 1                  | invalid            |
| 100             | 1        | 0                  | effective          |
| 101             | 1        | 1                  | invalid            |
| 110             | 1        | 1                  | invalid            |
| 111             | 0        | 1                  | invalid            |

#### 19.4.3.2 Receive process

During LPUART reception, the least significant bits of data are first moved in from the RX pin. In this mode, the LPUART\_DAT register contains a buffer between the internal APB bus and the receive shift register.

The steps for LPUART to receive data are as follows:

1. Configure baud rate, parity check, wake up event/enable, sampling mode, DMA, flow control, etc.

2. Check the interrupt flags of the LPUART\_STS register: buffer is not empty, buffer is half full, buffer is full, buffer overrun;
3. Read the data by reading the LPUART\_DAT register.
4. Return to Step 2 and continue receiving data.

*Note: please be sure to initialize the LPUART module before using the receiver.*

When receiving a data frame:

- The LPUART\_STS.FIFO\_NE bit is set, and the contents of the shift register are transferred to the RDR (Receiver Data Register). In other words, the data has been received and can be read (including its associated error flags).
- If the LPUART\_INTEN.FIFO\_NEIEN bit is set, an interrupt is generated.
- Frame errors (parity detection errors), noise or overrun errors are detected during reception, so the error flag will be set.
- In multi-buffer communication mode, the LPUART\_STS.FIFO\_NE flag bit is placed after each byte received and cleared by DMA's read operation on the data register.
- In single buffer mode, the software can clear LPUART\_STS.FIFO\_NE bits by reading the LPUART\_DAT register or by writing 0. The LPUART\_STS.FIFO\_NE bit must be cleared before the end of the next frame of data reception to avoid overrun errors.

#### 19.4.3.3 Overrun error

The LPUART receiving data buffer has a total of 32 bytes. The LPUART\_STS.FIFO\_FU flag will be set after receiving 32 bytes of data. When the buffer data is not read out and causes LPUART\_STS.FIFO\_FU to be not reset in time, if next character is received, an overrun error occurs. This character will be discarded by the hardware. Data can only be transferred from the shift register to the receiving data buffer if the LPUART\_STS.FIFO\_FU bit is cleared. If the next data has been received or the previous DMA request has not been served, the LPUART\_STS.FIFO\_FU flag is still set and an overrun error occurs.

When an overrun error occurs:

- The LPUART\_STS.FIFO\_OV bit is set.
- The receiving data buffer content will not be lost. Reading the LPUART\_DAT register still returns the previous data.
- The contents of the shift register will be overwritten. Any subsequent data received will be lost.
- If the LPUART\_INTEN.FIFO\_OVIE bit is set, an interrupt is generated.
- LPUART\_DAT register read operation, reset LPUART\_STS.FIFO\_OV.

#### 19.4.3.4 Noise error

Noise errors use an over-sampling technique (if the LPUART\_CTRL.SMPCNT bit is 0, meaning that the number of samples is 3) to recover data by distinguishing valid input data from noise.

Figure 19-4 Data Sampling for Noise Detection

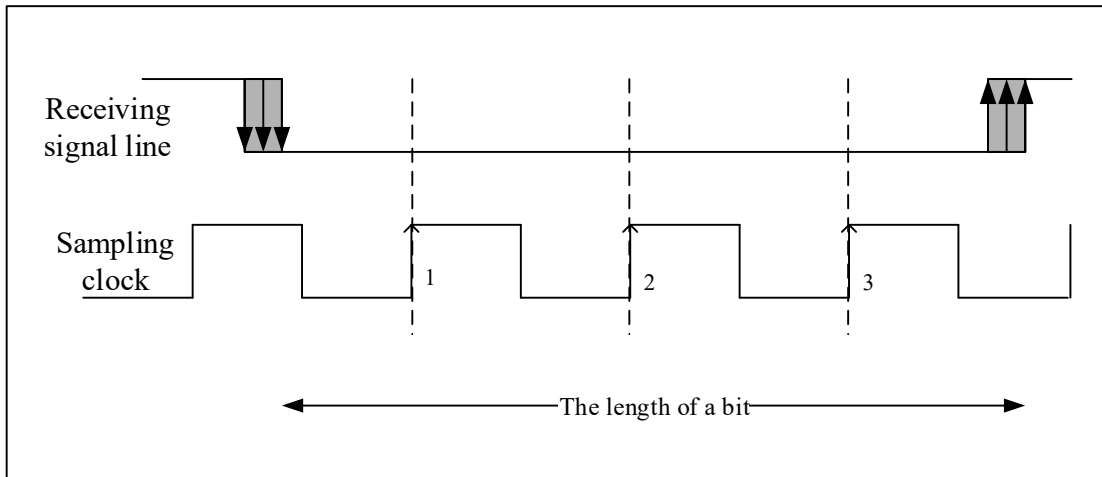


Table 19-1 Data Sampling for Noise Detection

| Sampling Values | NF State | Received Bit Value |
|-----------------|----------|--------------------|
| 000             | 0        | 0                  |
| 001             | 1        | 0                  |
| 010             | 1        | 0                  |
| 011             | 1        | 1                  |
| 100             | 1        | 0                  |
| 101             | 1        | 1                  |
| 110             | 1        | 1                  |
| 111             | 0        | 1                  |

When noise is detected in a receiving frame, you can do the following:

- If three sample values are inconsistent, set the LPUART\_STS.NF flag immediately.
- The received data is transferred from the shift register to the buffer.
- Software write 1 clears the LPUART\_STS.NF flag bit.

### 19.4.4 Fractional Baud Rate Generation

Baud rate frequency division coefficient is divided into 16-bit integer part and 8-bit decimal part. The baud rate generator uses the value of the combination of these two parts to determine the baud rate. The fractional baud rate divider will enable the LPUART to generate all standard baud rates.

Baud rate frequency division coefficient (LPUARTDIV) has the following relationship with system clock (PCLK) :

$$\text{TX/RX baud rate} = f_{CLK} / (\text{LPUARTDIV})$$

Here the  $f_{CLK}$  is the clock for LPUART (the clock source of LPUART can be HSI, HSE, LSI, LSE, SYSClk, or PCLK1).

The value of LPUARTDIV is set in the baud rate configuration registers LPUART\_BRCFG1 and LPUART\_BRCFG2

*Note: After writing LPUART\_BRCFG1 and LPUART\_BRCFG2, the baud rate counter is replaced with the new value of the baud rate register. Therefore, do not change the value of the baud rate register during communication.*

#### 19.4.4.1 Configure baud rates through LPUART\_BRCFG1 and LPUART\_BRCFG2

For example, baud rate = 4800bps, clock frequency = 32768Hz.

$LPUARTDIV = 32768/4800 = 6.82667$ . LPUART\_BRCFG1 = 6 and the value of LPUART\_BRCFG2 is calculated by adding fractions in the table below (the value of LPUART\_BRCFG2 is 0xEFh).

| Decimal Addition              | Carry To The Next Integer | Bit Field | Value |
|-------------------------------|---------------------------|-----------|-------|
| $0.82667 + 0.82667 = 1.65333$ | YES                       | DECIMAL0  | 1     |
| $1.65333 + 0.82667 = 2.48000$ | YES                       | DECIMAL1  | 1     |
| $2.48000 + 0.82667 = 3.30667$ | YES                       | DECIMAL2  | 1     |
| $3.30667 + 0.82667 = 4.13333$ | YES                       | DECIMAL3  | 1     |
| $4.13333 + 0.82667 = 4.96000$ | NO                        | DECIMAL4  | 0     |
| $4.96000 + 0.82667 = 5.78667$ | YES                       | DECIMAL5  | 1     |
| $5.78667 + 0.82667 = 6.61333$ | YES                       | DECIMAL6  | 1     |
| $6.61333 + 0.82667 = 7.44000$ | YES                       | DECIMAL7  | 1     |

When LSE clock (32.768KHz) is used, the values of baud rate configuration registers LPUART\_BRCFG1 and LPUART\_BRCFG2 with different baud rate settings are as follows:

| Baud Rate | Divisor  | LPUART_BRCFG1 | LPUART_BRCFG2 |
|-----------|----------|---------------|---------------|
| 300       | 109.2267 | 6Dh           | 88h           |
| 600       | 54.6133  | 36h           | ADh           |
| 1200      | 27.3067  | 1Bh           | 24h           |
| 2400      | 13.6533  | 0Dh           | 6Dh           |
| 4800      | 6.8267   | 06h           | EFh           |
| 9600      | 3.4133   | 03h           | 4Ah           |

*Note: The lower the clock frequency of the CPU, the lower the accuracy of a particular baud rate.*

#### 19.4.5 Parity Control

Reset the LPUART\_CTRL.PCDIS bit, enable parity control (generate a parity bit when transmission, do parity check when



reception, set or reset the LPUART\_CTRL.PSEL bit selection to use odd or even check). LPUART frame formats are listed in the table below.

**Table 19-2 Parity Frame Format**

| PCDIS Bit | LPUART Frame                                   |
|-----------|--|
| 0         | Start bit   8-bit data   parity bit   stop bit |
| 1         | Start bit   8 bits data   stop bit             |

Transfer mode: Parity is enabled by resetting the LPUART\_CTRL.PCDIS bit. If parity fails, the LPUART\_STS.PEF flag is set to '1', and an interrupt will be triggered if LPUART\_INTEN.PEIE is set.

Odd parity: LPUART\_CTRL.PSEL=1.

Make the number of '1' in one frame data (including parity bit) be an odd number. For example: if data=11000101, there are 4 '1', then the parity bit will be '1' (5 '1' in total).

Even parity: LPUART\_CTRL.PSEL=0.

Make the number of '1' in one frame data (including parity bit) be an even number. For example: if data=11000101, there are 4 '1', then the parity bit will be '0' (4 '1' in total).

## 19.4.6 DMA Application

LPUART can access the transmit data register (TDR) and receive buffer respectively through DMA.

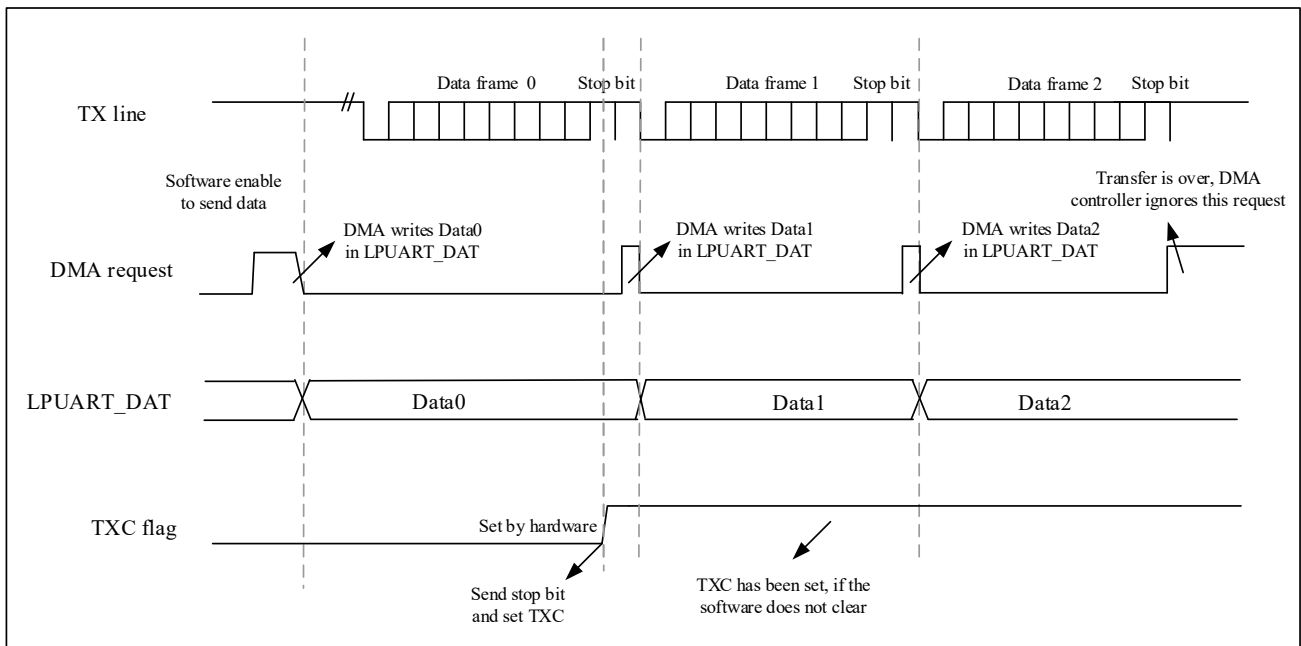
### 19.4.6.1 DMA transmission

The steps for assigning a DMA channel to the LPUART transmissions are as follows (x indicates the channel number) :

1. Configure the LPUART\_DAT register address as the destination address for DMA transfer, and the memory address as the source address for DMA transfer.
2. Set the total number of bytes to be transmitted.
3. Set the channel priority.
4. Configure to trigger DMA interrupts when the transfer is half or all complete.
5. Activate the channel.

Completing a DMA transfer will trigger an interrupt on the corresponding DMA channel. In transmission mode, when the DMA has finished the data transfer, the DMA controller sets the DMA\_INTSTS.TXCFx flag. The LPUART\_STS.TXC flag bit is asserted by the hardware to indicate that the transfer is completed. The software needs wait for LPUART\_STS.TXC=1.

Figure 19-5 Sending Using DMA



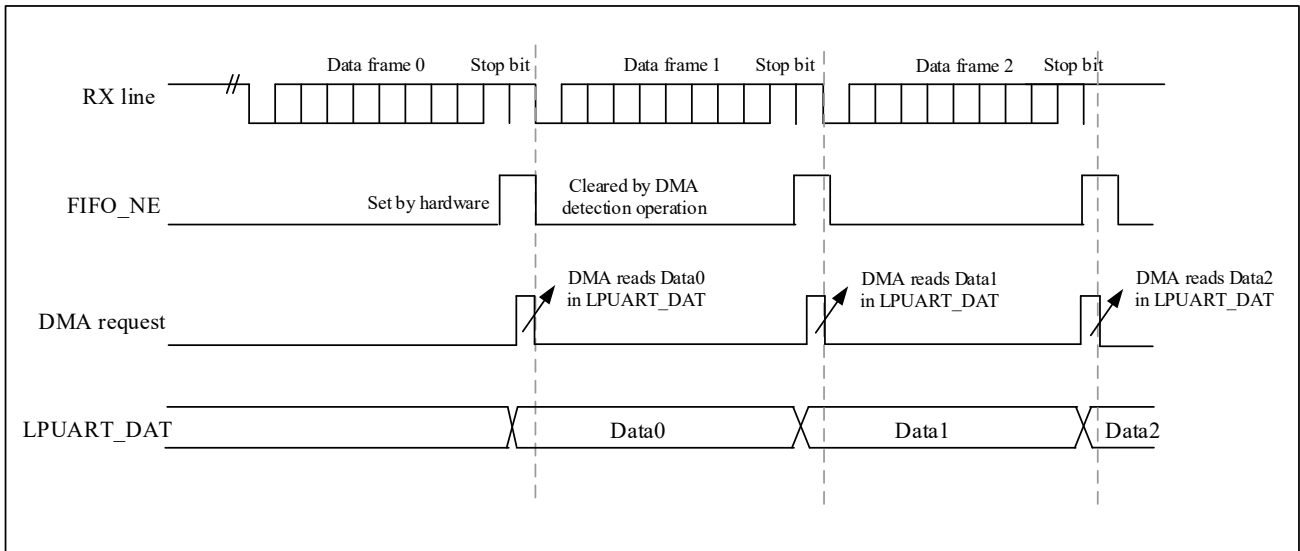
**19.4.6.2 DMA reception**

The steps for assigning a DMA channel to the LPUART receiving are as follows (x indicates the channel number) :

1. Configure the LPUART\_DAT register address as the source address for transmission and the memory address as the destination address for transmission through the DMA configuration register.
2. Configure the number of DMA bytes to be transferred.
3. Configure the channel priority on the DMA register for data transfer.
4. Configure interrupts to trigger DMA interrupts when the transfer is half or all complete.
5. Activate the channel.

When completing the transfer specified by the DMA controller, the DMA controller triggers an interrupt on the DMA channel's interrupt vector.

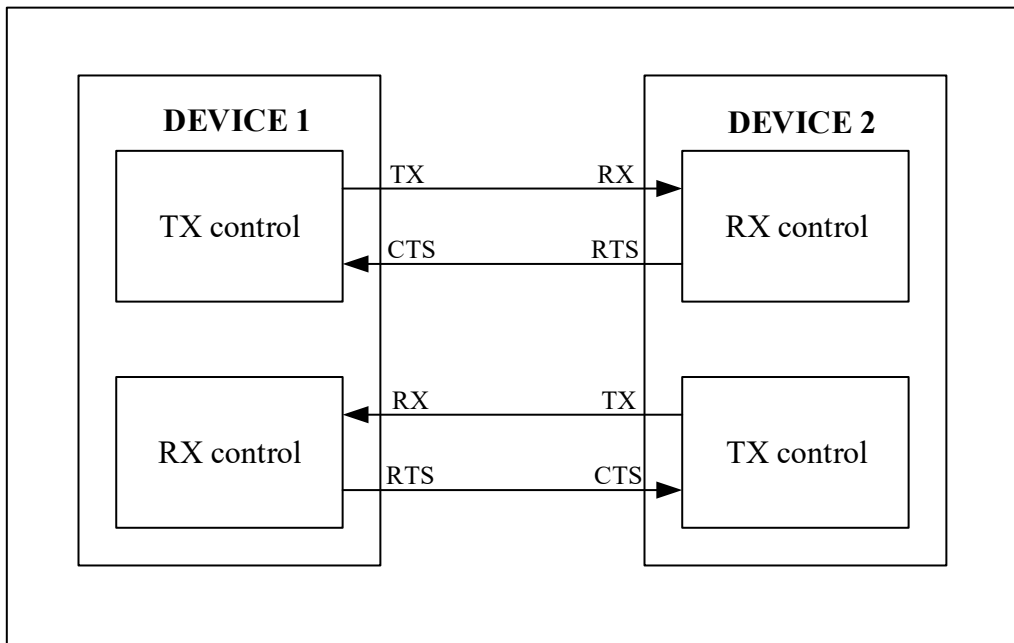
Figure 19-6 Receiving with DMA



### 19.4.7 Hardware Flow Control

Hardware flow control functions through CTS input and RTS output. The following figure shows how two devices are connected in this mode.

Figure 19-7 Hardware Flow Control Between Two LPUART



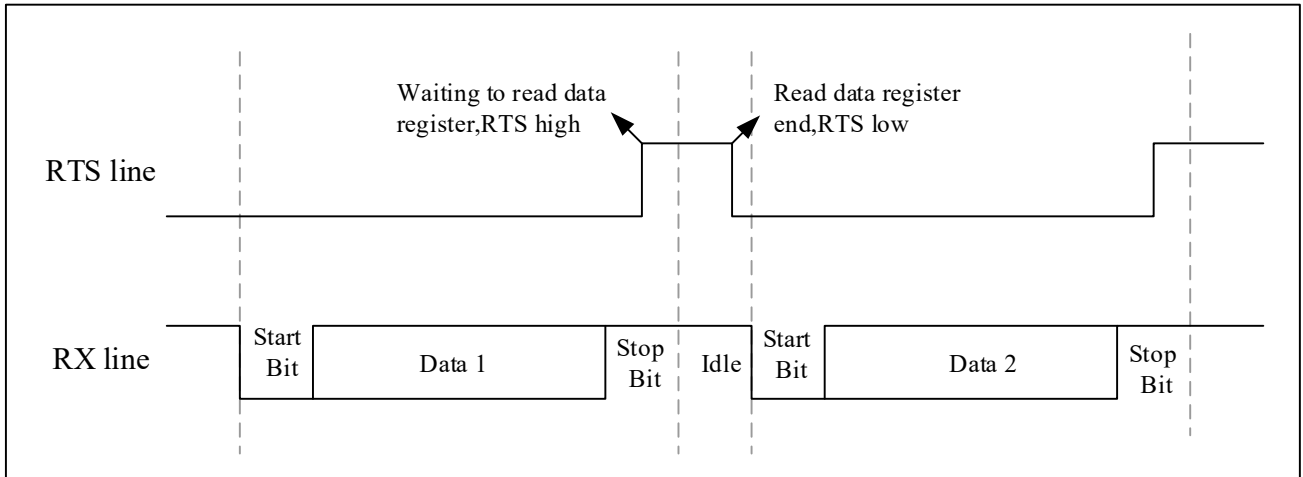
RTS and CTS flow control can be independently enabled by setting LPUART\_CTRL.RTSSEN and LPUART\_CTRL.CTSSEN.

#### 19.4.7.1 RTS flow control

If RTS flow control is enabled (LPUART\_CTRL.RTSSEN=1), the RTS will be driven high (active) when the RTS threshold

condition is achieved, otherwise it will be driven low. How is the RTS valid can be selected by the LPUART\_CTRL.RTS\_THSEL[1:0] bits. The RTS threshold can be selected to be effective when the FIFO is half full, 3/4 full, or full. Below is an example of communication with RTS flow control enabled.

Figure 19-8 RTS Flow Control

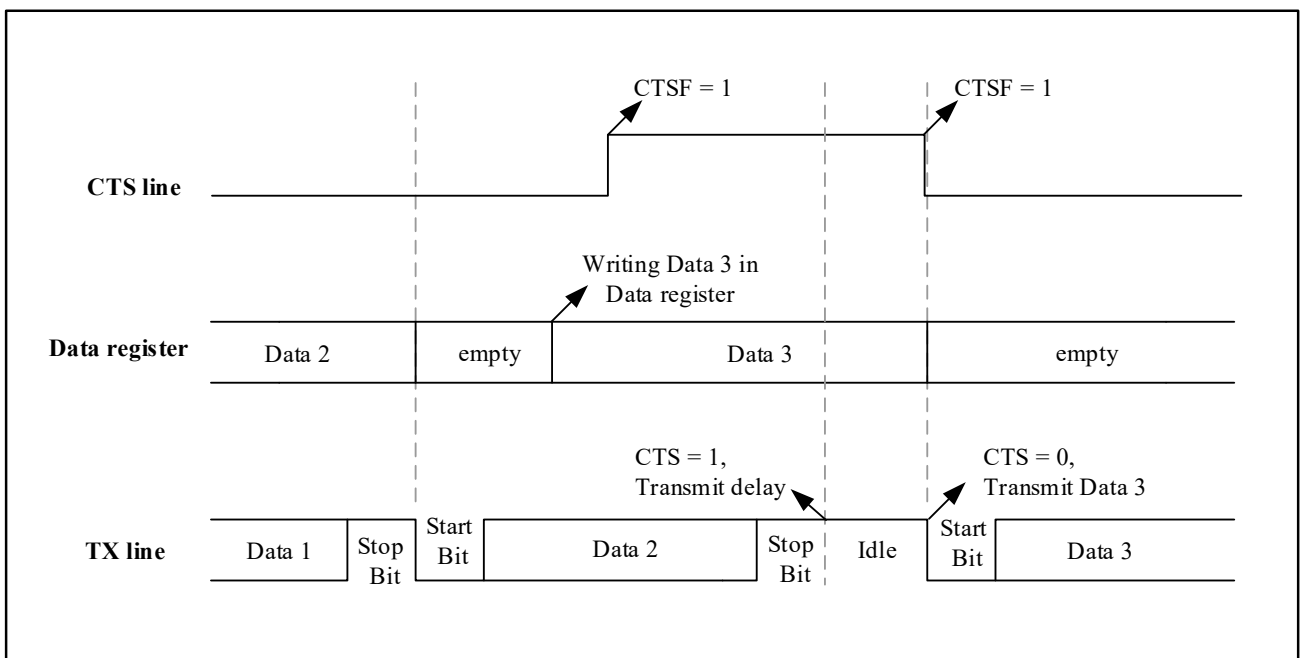


19.4.7.2 CTS flow control

If CTS flow control is enabled (LPUART\_CTRL.CTSEN=1), the transmitter will check the CTS pin to decide whether or not send data before sending the next frame. If the CTS is pulled low (valid), the transmitter transmits data (assuming that data is ready to be sent). If the CTS is pulled up during transmission, the transmission of the current data frame is stopped after transmission.

If CTS flow control is enabled (LPUART\_CTRL.CTSEN=1), the signal of CTS pin will be changed. Refer to Figure 19-9 for enabling CTS flow control.

Figure 19-9 CTS Flow Control



### 19.4.8 Low Power Wake Up

LPUART can operate in STOP mode, if the LPUART\_CTRL.WUSTP is set, it can wake up the system on EXTI line 22 when a specific waking up event occurs.

The LPUART waking up event can be generated in the following ways (through the LPUART\_CTRL.WUSEL[1:0]) :

- A waking up event is generated when a start bit is detected
- A waking up event is generated when the receive buffer non-empty flag is set
- A waking up event is generated when data is received and the first byte matches LPUART\_WUDAT[7:0]
- A waking up event is generated when data is received and four bytes match LPUART\_WUDAT[31:0]

When waking up event occurs, the LPUART\_STS.WUF bit will be set.

## 19.5 Interrupt Request

Table 19-3 LPUART Interrupt Requests

| Interrupt Function      | Interrupt Event          | Event Flag | Enable Bit |
|-------------------------|--------------------------|------------|------------|
| LPUART global interrupt | Parity check error       | PEF        | PEIE       |
|                         | TX complete              | TXC        | TXCIE      |
|                         | Receive buffer overrun   | FIFO_OV    | FIFO_OVIE  |
|                         | Receive buffer full      | FIFO_FU    | FIFO_FUIE  |
|                         | Receive buffer half full | FIFO_HF    | FIFO_HFIE  |
|                         | Receive buffer not empty | FIFO_NE    | FIFO_NEIE  |
|                         | Wake up in STOP mode     | WUF        | WUFIE      |

LPUART interrupt events are logical OR. If the corresponding enable control bit is set, these events can trigger their own interrupt, but only one interrupt request can be triggered at the same time.

## 19.6 LPUART Registers

### 19.6.1 LPUART Register Overview

Table 19-4 LPUART Register Overview

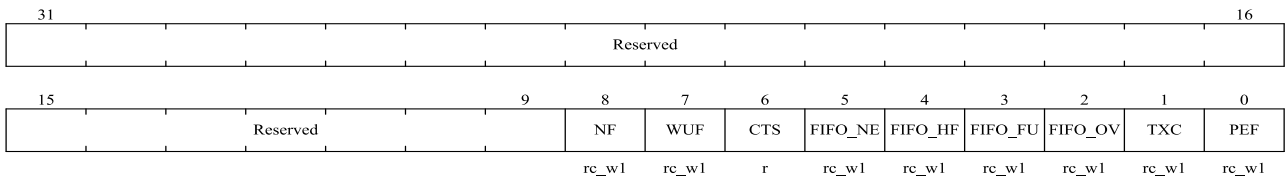
| Offset | Register     | 31       | 30 | 29 | 28 | 27 | 26 | 25 | 24 | 23 | 22 | 21 | 20 | 19 | 18 | 17 | 16 | 15 | 14 | 13 | 12 | 11 | 10 | 9     | 8         | 7         | 6         | 5         | 4       | 3       | 2   | 1   | 0 |  |  |  |  |  |
|--------|--------------|----------|----|----|----|----|----|----|----|----|----|----|----|----|----|----|----|----|----|----|----|----|----|-------|-----------|-----------|-----------|-----------|---------|---------|-----|-----|---|--|--|--|--|--|
| 000h   | LPUART_STS   | Reserved |    |    |    |    |    |    |    |    |    |    |    |    |    |    |    |    |    |    |    |    |    | NF    | WUF       | CTS       | FIFO_NE   | FIFO_HF   | FIFO_FU | FIFO_OV | TXC | PEF |   |  |  |  |  |  |
|        | Reset Value  |          |    |    |    |    |    |    |    |    |    |    |    |    |    |    |    |    |    |    |    |    |    | 0     | 0         | 0         | 0         | 0         | 0       | 0       | 0   |     |   |  |  |  |  |  |
| 004h   | LPUART_INTEN | Reserved |    |    |    |    |    |    |    |    |    |    |    |    |    |    |    |    |    |    |    |    |    | WUFIE | FIFO_NEIE | FIFO_HFIE | FIFO_FUIE | FIFO_OVIE | TXCIE   | PEIE    |     |     |   |  |  |  |  |  |
|        | Reset Value  |          |    |    |    |    |    |    |    |    |    |    |    |    |    |    |    |    |    |    |    |    |    | 0     | 0         | 0         | 0         | 0         | 0       | 0       |     |     |   |  |  |  |  |  |

| Offset | Register      | 31          | 30 | 29 | 28 | 27 | 26 | 25 | 24 | 23 | 22 | 21 | 20 | 19 | 18 | 17            | 16          | 15 | 14    | 13    | 12              | 11    | 10       | 9        | 8        | 7     | 6     | 5    | 4    | 3 | 2 | 1 | 0 |   |   |   |   |
|--------|---------------|-------------|----|----|----|----|----|----|----|----|----|----|----|----|----|---------------|-------------|----|-------|-------|-----------------|-------|----------|----------|----------|-------|-------|------|------|---|---|---|---|---|---|---|---|
| 008h   | LPUART_CTRL   | Reserved    |    |    |    |    |    |    |    |    |    |    |    |    |    | SMPCNT        | WUSEL [1:0] |    | RTSEN | CTSEN | RTS_THSEL [1:0] | WUSTP | DMA_RXEN | DMA_TXEN | LOOPBACK | PCDIS | FLUSH | TXEN | PSEL |   |   |   |   |   |   |   |   |
|        | Reset Value   |             |    |    |    |    |    |    |    |    |    |    |    |    |    | 0             | 0           | 0  | 0     | 0     | 0               | 1     | 0        | 0        | 0        | 0     | 0     | 0    | 0    | 0 | 0 | 0 | 0 | 0 | 0 | 0 | 0 |
| 00Ch   | LPUART_BRCFG1 | Reserved    |    |    |    |    |    |    |    |    |    |    |    |    |    | INTEGER[15:0] |             |    |       |       |                 |       |          |          |          |       |       |      |      |   |   |   |   |   |   |   |   |
|        | Reset Value   |             |    |    |    |    |    |    |    |    |    |    |    |    |    | 0             | 0           | 0  | 0     | 0     | 0               | 0     | 0        | 0        | 0        | 1     | 0     | 1    | 1    | 1 | 1 | 0 | 1 | 0 | 0 | 0 |   |
| 010h   | LPUART_DAT    | Reserved    |    |    |    |    |    |    |    |    |    |    |    |    |    | DAT[7:0]      |             |    |       |       |                 |       |          |          |          |       |       |      |      |   |   |   |   |   |   |   |   |
|        | Reset Value   |             |    |    |    |    |    |    |    |    |    |    |    |    |    | 0             | 0           | 0  | 0     | 0     | 0               | 0     | 0        | 0        | 0        |       |       |      |      |   |   |   |   |   |   |   |   |
| 014h   | LPUART_BRCFG2 | Reserved    |    |    |    |    |    |    |    |    |    |    |    |    |    | DECIMAL[7:0]  |             |    |       |       |                 |       |          |          |          |       |       |      |      |   |   |   |   |   |   |   |   |
|        | Reset Value   |             |    |    |    |    |    |    |    |    |    |    |    |    |    | 0             | 0           | 0  | 0     | 0     | 0               | 0     | 0        | 0        | 0        |       |       |      |      |   |   |   |   |   |   |   |   |
| 018h   | LPUART_WUDAT  | WUDAT[31:0] |    |    |    |    |    |    |    |    |    |    |    |    |    |               |             |    |       |       |                 |       |          |          |          |       |       |      |      |   |   |   |   |   |   |   |   |
|        | Reset Value   | 0           | 0  | 0  | 0  | 0  | 0  | 0  | 0  | 0  | 0  | 0  | 0  | 0  | 0  | 0             | 0           | 0  | 0     | 0     | 0               | 0     | 0        | 0        | 0        | 0     | 0     | 0    | 0    | 0 | 0 | 0 | 0 |   |   |   |   |

### 19.6.2 LPUART Status Register (LPUART\_STS)

Address offset: 0x00

Reset value: 0x0000 0000



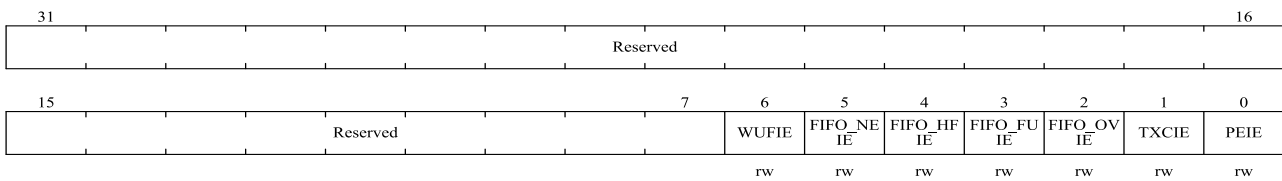
| Bit Field | Name     | Description  |
|-----------|----------|--|
| 31:9      | Reserved | Reserved, the reset value must be maintained.  |
| 8         | NF       | Noise detected flag.<br>When noise is detected in the received frame, this bit is set by hardware. This bit is cleared by the software.<br>0: No noise is detected.<br>1: Noise is detected. |
| 7         | WUF      | Wakeup from STOP mode Flag.<br>0: No wake up event is detected.<br>1: A wake up event is detected.   |
| 6         | CTS      | CTS signal (hardware flow control) flag.<br>Once the sender requests to send data, it is ready to receive it.<br>0: CTS line is reset.<br>1: CTS line is set.                                |
| 5         | FIFO_NE  | FIFO non-empty flag.<br>0: Buffer is empty.<br>1: Buffer is not empty. RX data is ready to be read   |
| 4         | FIFO_HF  | FIFO half full flag.<br>0: Buffer is not half full.  |

| Bit Field | Name    | Description  |
|-----------|---------|--|
|           |         | 1: Buffer is half full.RX data should be read before the buffer is full  |
| 3         | FIFO_FU | FIFO full flag.<br>0: Buffer is not full.<br>1: Buffers is full.RX data should be read out in preparation for receiving new data |
| 2         | FIFO_OV | FIFO overrun flag.<br>0: Buffer did not overrun<br>1: Buffer overrun.  |
| 1         | TXC     | TX complete flag.<br>0: TX is disabled or not complete.<br>1: TX transmission is complete.                                       |
| 0         | PEF     | Parity check error flag.<br>0: No parity error detected.<br>1: Parity error detected   |

### 19.6.3 LPUART Interrupt Enable Register (LPUART\_INTEN)

Address offset: 0x04

Reset value: 0x0000 0000



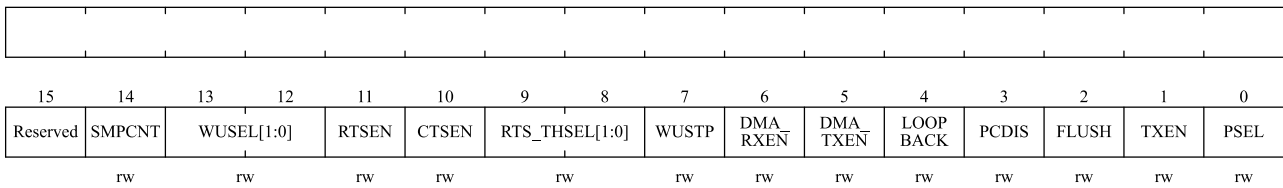
| Bit Field | Name      | Description  |
|-----------|-----------|--|
| 31:7      | Reserved  | Reserved, the reset value must be maintained.  |
| 6         | WUFIE     | Wake up interrupt enable<br>0: Disable wake up interrupt<br>1: Enable wake up interrupt                                      |
| 5         | FIFO_NEIE | Receive buffer not empty interrupt enable<br>0: Disable buffer non-empty interrupt<br>1: Enable buffer non-empty interrupt   |
| 4         | FIFO_HFIE | Receive buffer half-full interrupt enable<br>0: Disables buffer half-full interrupt<br>1: Enables buffer half-full interrupt |
| 3         | FIFO_FU   | Receive buffer full interrupt enable<br>0: Disables buffer full interrupt<br>1: Enable buffer full interrupt                 |
| 2         | FIFO_OVIE | Receive buffer overrun interrupt enable<br>0: Disables buffer overrun interrupt<br>1: Enable buffer overrun interrupt        |
| 1         | TXCIE     | TX complete interrupt enable   |

| Bit Field | Name | Description  |
|-----------|------|--|
|           |      | 0: Disable TX complete interrupt<br>1: Enable TX complete interrupt  |
| 0         | PEIE | Parity check error interrupt enable<br>0: Disable parity error interrupt<br>1: Enable parity error interrupt |

### 19.6.4 LPUART Control Register (LPUART\_CTRL)

Address offset: 0x08

Reset value: 0x0000 0200



| Bit Field | Name           | Description   |
|-----------|----------------|---|
| 31:15     | Reserved       | Reserved, the reset value must be maintained.   |
| 14        | SMPCNT         | Specify sampling method<br>0: 3 sample bits, noise detection is allowed (LPUARTDIV should be large enough, such as greater than 10)<br>1: 1 sample bits, closed noise detection           |
| 13:12     | WUSEL[1:0]     | Wake up event selection.<br>00: Start bit detection<br>01: Non-empty detection of receive buffer<br>10: A configurable receive byte<br>11: A programmable 4-byte frame                    |
| 11        | RTSEN          | RTS hardware flow control enable<br>0: Disables RTS hardware flow control<br>1: Enables RTS hardware flow control   |
| 10        | CTSEN          | CTS hardware flow control enable<br>0: Disables CTS hardware flow control<br>1: Enables CTS hardware flow control   |
| 9:8       | RTS_THSEL[1:0] | RTS threshold selection<br>00: When FIFO is half full, RTS is effective (pull up)<br>x1: When FIFO is 3/4 full, RTS effective (pull up)<br>10: When FIFO is full, RTS effective (pull up) |
| 7         | WUSTP          | LPUART STOP mode wakeup enabled<br>0: Cannot wake up STOP mode<br>1: Can wake up the STOP mode  |
| 6         | DMA_RXEN       | DMA RX request enable   |

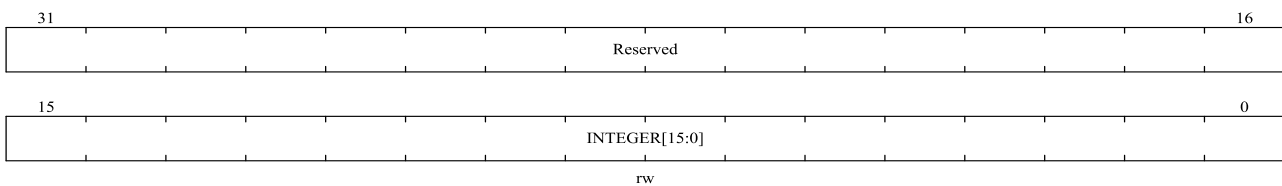


| Bit Field | Name     | Description   |
|-----------|----------|---|
| 5         | DMA_TXEN | DMA TX request enable   |
| 4         | LOOKBACK | Loopback self-test<br>0: Normal mode<br>1: Loopback self-test mode          |
| 3         | PCDIS    | Parity control<br>0: Enables parity bit<br>1: Disables parity bit           |
| 2         | FLUSH    | Clear receive buffer<br>0: Disables buffer clear<br>1: Clear buffer content |
| 1         | TXEN     | TX enable<br>0: Disables TX<br>1: Enables TX                                |
| 0         | PSEL     | Odd parity enable<br>0: Even parity<br>1: Odd parity                        |

### 19.6.5 LPUART Baud Rate Configuration Register 1 (LPUART\_BRCFG1)

Address offset: 0x0C

Reset value: 0x0000 0174

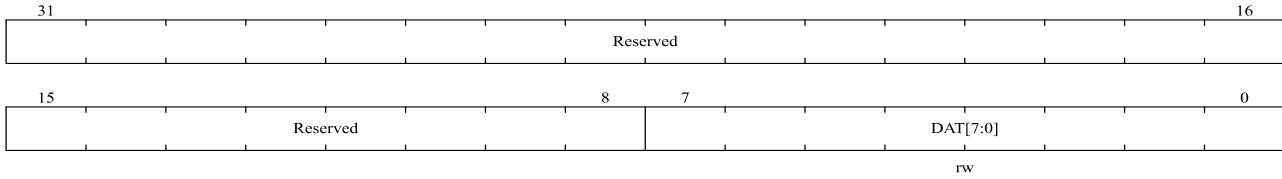


| Bit Field | Name          | Description   |
|-----------|---------------|---|
| 31:16     | Reserved      | Reserved, the reset value must be maintained.   |
| 15:0      | INTEGER[15:0] | Baud rate configuration register 1.<br>The calculation of baud rate configuration register 1 is as follows:<br>If the baud rate is 9600bps and the clock frequency is 32768Hz.<br>$LPUARTDIV = 32768/9600 = 3.4133$<br>In this case, the integer part of the LPUARTDIV is 3 and the decimal part is 0.4133. LPUART_BRCFG1 = 3. LPUART_BRCFG2 will be used for baud rate error correction. For the 3-bit sampling method with noise detection characteristics, LPUARTDIV is not large enough at this time, so 1-bit sampling method should be adopted to avoid sampling error. |

### 19.6.6 LPUART Data Register (LPUART\_DAT)

Address offset: 0x10

Reset value: 0x0000 0000

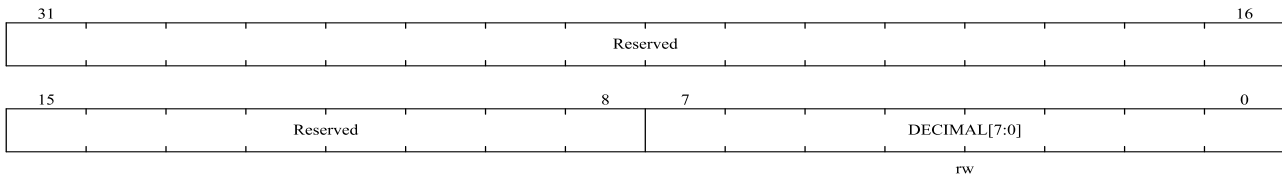


| Bit Field | Name     | Description   |
|-----------|----------|---|
| 31:8      | Reserved | Reserved, the reset value must be maintained.   |
| 7:0       | DAT[7:0] | Write to the data register when transmitting<br>Read the data register when receiving |

### 19.6.7 LPUART Baud Rate Configuration Register 2 (LPUART\_BRCFG2)

Address offset: 0x14

Reset value: 0x0000 0000

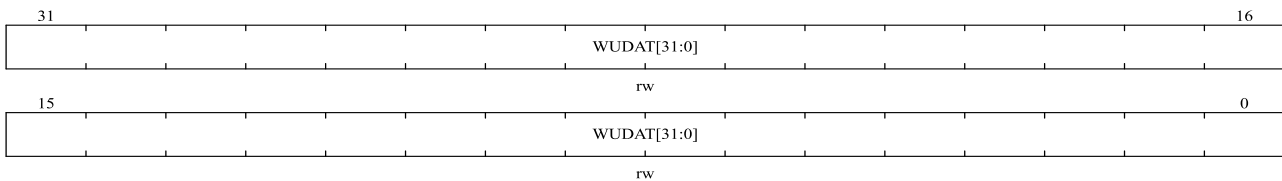


| Bit Field | Name         | Description  |
|-----------|--------------|--|
| 31:8      | Reserved     | Reserved, the reset value must be maintained.  |
| 7:0       | DECIMAL[7:0] | Baud rate configuration register 2 is used for baud rate error correction at low frequencies. For example,<br>If the baud rate is 4800bps and the clock frequency is 32768Hz.<br>$LPUARTDIV = 32768/4800 = 6.8266$<br>$LPUART\_BRCFG1 = 6$ . In this case, to correct the baud rate error, you should configure register 2 with baud rate. For details on how to configure register 2, refer to the section "Fractional Baud Rate Generation". |

### 19.6.8 LPUART Wake Up Data Register (LPUART\_WUDAT)

Address offset: 0x18

Reset value: 0x0000 0000



| Bit Field | Name        | Description  |
|-----------|-------------|--|
| 31:0      | WUDAT[31:0] | When LPUART_CTRL.WUSEL[1:0] = 1x, WUDAT[31:0] is used to check whether the conditions for wake up from STOP mode is matched (byte match or frame match): |

| Bit Field | Name | Description  |
|-----------|------|--|
|           |      | <p>LPUART_CTRL.WUSEL[1:0] = 10 is used to wake up byte matching. In this case, the first byte is valid</p> <p>LPUART_CTRL.WUSEL[1:0] = 11 is used to wake up frame matching. In this case, all 4 bytes are valid</p> |

## 20 Serial Peripheral Interface/Inter-IC Sound (SPI/ I<sup>2</sup>S)

### 20.1 SPI and I<sup>2</sup>S Introductions

This module is about SPI/I<sup>2</sup>S. It operates in SPI mode by default and users can choose to use I<sup>2</sup>S by setting the registers.

Serial peripheral interface (SPI) is able to operate in master or slave mode, supports full-duplex and half-duplex high-speed communication mode, and have hardware CRC calculation and configurable multi-master mode.

Inter-IC sound (I<sup>2</sup>S) is able to operate in master and slave modes in half-duplex communication, and supports four audio standards: Philips I<sup>2</sup>S standard, MSB alignment standard, LSB alignment standard and PCM standard.

### 20.2 SPI and I<sup>2</sup>S Main Features

#### 20.2.1 SPI Features

- 3-wire full-duplex synchronous transmission
- Two-wire simplex synchronous transmission with or without a third bidirectional data line
- 8 or 16 bit transmission frame format selection
- Master or slave operations
- Supports multi-master mode
- Fast communication between master mode and slave mode
- NSS can be managed by software or hardware in both master and slave modes: dynamic change of master/slave modes
- Programmable clock polarity and phase
- Programmable data order, MSB before or LSB before
- Dedicated transmit and receive flags that trigger interrupts
- SPI bus busy flag
- Hardware CRC for reliable communication
  - In transmit mode, the CRC value can be transmitted as the last byte
  - In full-duplex mode, CRC is automatically performed on the last byte received
- Master mode failures, overloads, and CRC error flags that trigger interrupts
- Single-byte send and receive buffer with DMA capability: generates transmit and receive requests
- Maximum interface speed: 18Mbps

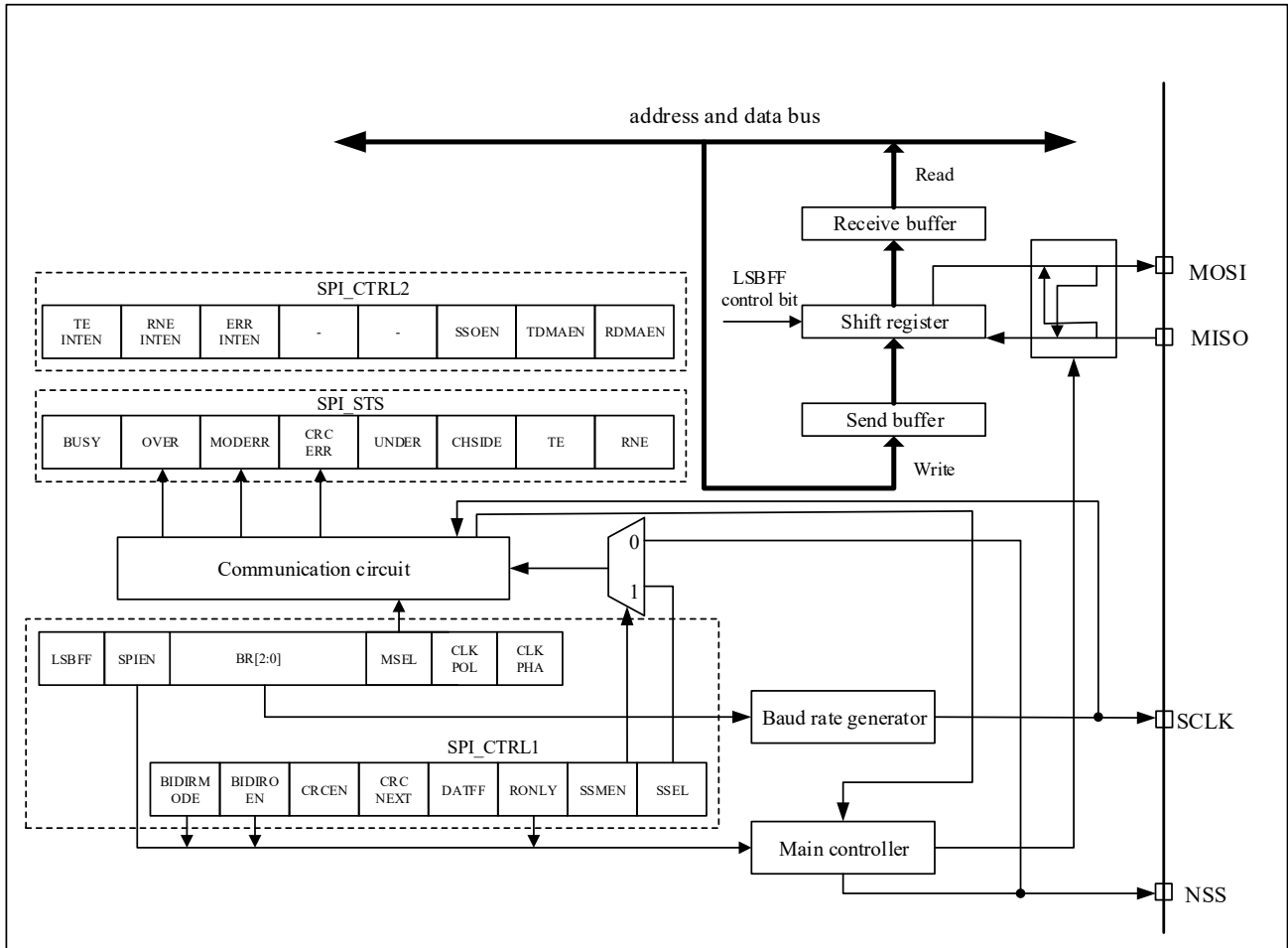
### 20.2.2 I<sup>2</sup>S Features

- Simplex communication (transmit or receive only)
- Master or slave operations
- 8-bit linear programmable prescaler for accurate audio sampling frequencies (8 KHZ to 96KHz)
- The data format can be 16, 24, or 32 bits
- Audio channel fixed packet frame is 16 bit (16 bit data frame) or 32 bit (16, 24 or 32 bit data frame)
- Programmable clock polarity (steady state)
- The overflows flag bit in slave transmitting mode and the overflows flag bit in master/slave receiving mode
- 16-bit data registers are used for transmitting and receiving, with one register at each end of the channel
- Supports I<sup>2</sup>S protocols
  - I<sup>2</sup>S Philips standard
  - MSB alignment standard (left aligned)
  - LSB alignment standard (right aligned)
  - PCM standard (16-bit channel frame with long or short frame synchronization or 16-bit data frame extension to 32-bit channel frame)
- The data direction is always MSB first
- Both transmit and receive have DMA capability
- The master clock can be output to external audio devices at a fixed rate of 256xFs (Fs is the audio sampling frequency)

## 20.3 SPI Function Description

### 20.3.1 General Description

Figure 20-1 SPI Block Diagram



To connect external devices, SPI has four pins, which are as follows:

- **SCLK:** serial clock pin. Serial clock signal is output from the SCLK pin of master device and input to SCLK pin of slave device.
- **MISO:** master input/slave output pin. Data is received from the MISO pin of master device and transmitted from the MISO pin of slave device.
- **MOSI:** master output/slave input pin. Data is transmitted from the MOSI pin of master device and received from the MOSI pin of slave device.
- **NSS:** chip select pin. There are two types of NSS pin, internal pin and external pin. If the internal pin detects a high level, SPI operates in the master mode. Conversely, SPI operates in the slave mode. Users can use a standard I/O pin of the master device to control the NSS pin of the slave device.

**20.3.1.1 Software NSS mode**

The software slave device management is enabled when  $SPI\_CTRL1.SSMEN = 1$

The NSS pin is not used in software NSS mode. In this mode the internal NSS signal level is driven by writing the  $SPI\_CTRL1.SSEL$  bit (master mode  $SPI\_CTRL1.SSEL = 1$ , slave mode  $SPI\_CTRL1.SSEL = 0$ ).

**20.3.1.2 Hardware NSS mode**

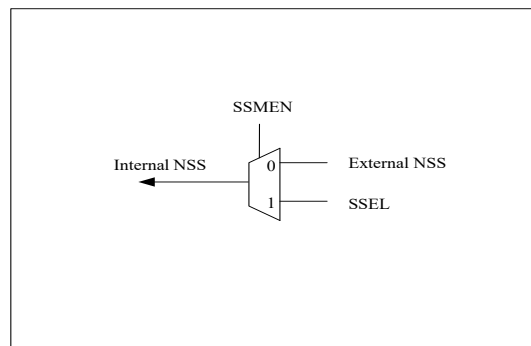
The software slave device management is disabled when  $SPI\_CTRL1.SSMEN = 0$ .

NSS input mode: The NSS output of the master device is disabled ( $SPI\_CTRL1.MSEL = 1$ ,  $SPI\_CTRL2.SSOEN = 0$ ), allowing operation in multi-master mode. The master should connect NSS pin to the high level and the slave should connect NSS pin to the low level during the entire data frame transfer.

NSS output mode: The NSS output of the master device is enable ( $SPI\_CTRL1.MSEL = 1$ ,  $SPI\_CTRL2.SSOEN = 1$ ). SPI as the master device must pull the NSS pin to low level, all device which connected to the master device and set to NSS hardware mode, will detect low level and enter the slave mode automatically. If the master device cannot pull the NSS pin to low level, device will enter the slave mode and generates the master mode failure error.

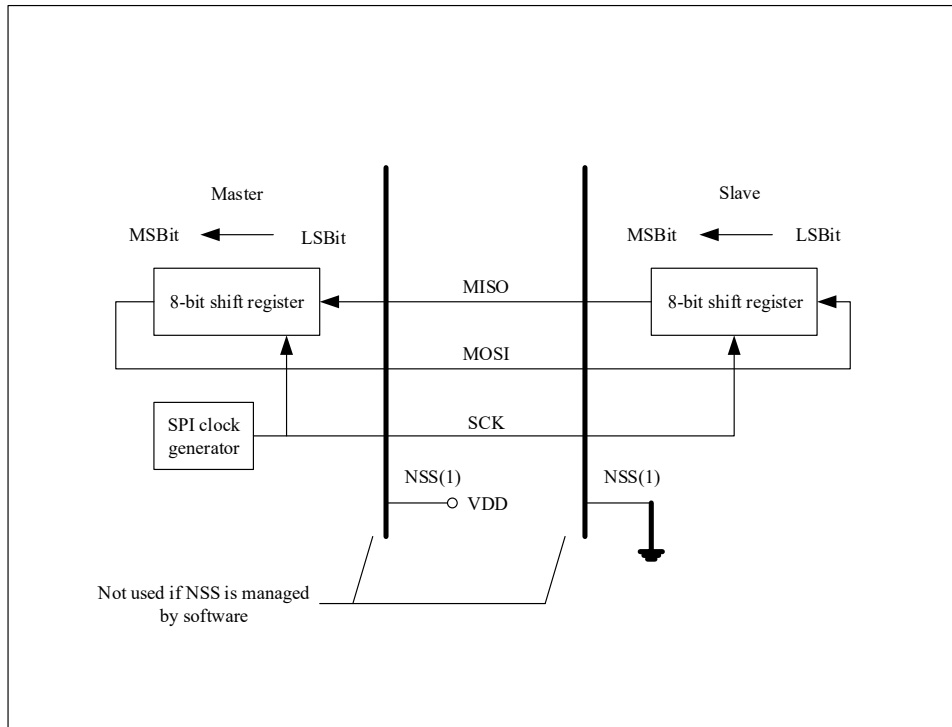
*Note: The choice of software mode or hardware mode depends on whether NSS control is needed in the communication protocol. If not, you can choose the software mode, and release a GPIO pin for other purposes.*

**Figure 20-2 Selective Management of Hardware/Software**



The following figure is an example of the interconnection of single master and single slave devices.

Figure 20-3 Master and Slave Applications



Note: NSS pin is set as input

The master device outputs a synchronous clock signal through the SCK pin, the MOSI pin of the master device is connected to the MOSI pin of the slave device, and the MISO pin of the master device is connected to the MISO pin of the slave device, so that data can be transferred between devices. Continuous data transfer between master and slave, transmitting data to slave through MOSI pin and slave transmitting data to master through MISO pin.

**20.3.1.3 SPI timing mode**

User can select the clock edge of data capture by setting SPI\_CTRL1.CLKPOL bit and SPI\_CTRL1.CLKPHA bit.

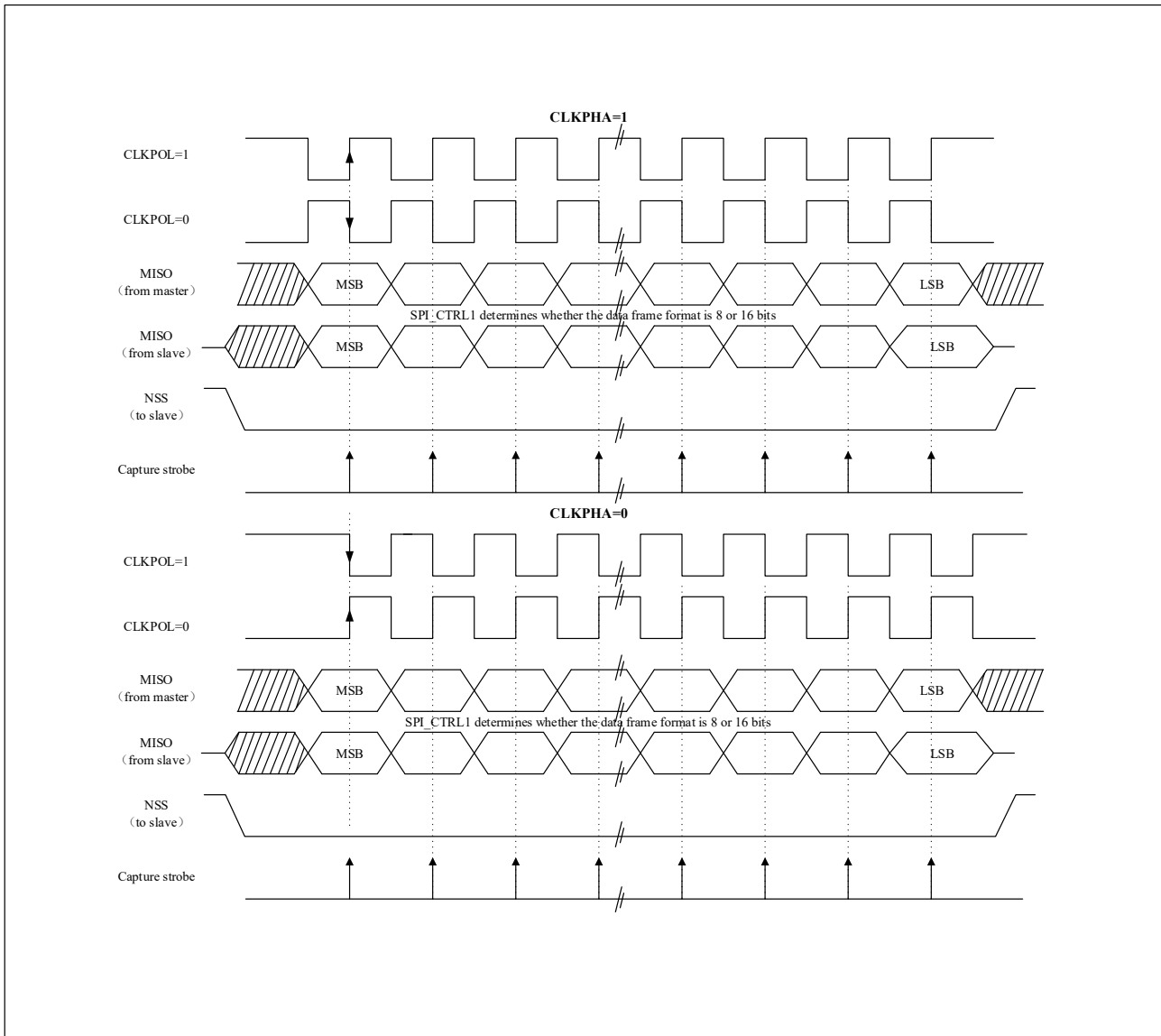
- When CLKPOL = 0, CLKPHA = 0, the SCLK pin will keep low in idle state, and the data will be sampled at the first edge, which is rising edge.
- When CLKPOL = 0, CLKPHA = 1, the SCLK pin will keep low in idle state, and the data will be sampled at the second edge, which is falling edge.
- When CLKPOL = 1, CLKPHA = 0, the SCLK pin will keep high in idle state, and the data will be sampled at the first edge, which is falling edge.
- When CLKPOL = 1, CLKPHA = 1, the SCLK pin will keep high in idle state, and the data will be sampled at the second edge, which is rising edge.

Regardless of the timing mode used, the master and slave configuration must be the same.

Figure 20-4 is the combination timing of four CLKPHA and CLKPOL bits transmitted by SPI when the SPI\_CTRL1.LSBFF = 0.



Figure 20-4 Data Clock Timing Diagram



### 20.3.1.4 Data format

User can select the data order by setting the SPI\_CTRL1.LSBFF bit. When SPI\_CTRL1.LSBFF = 0, SPI will transmit the most significant bit (MSB) first; When SPI\_CTRL1.LSBFF = 1, SPI will transmit the least significant bit (LSB) first.

User can select the data frame by setting the SPI\_CTRL1.DATFF bit.

## 20.3.2 SPI Operating Mode

### 20.3.2.1 Master full duplex mode

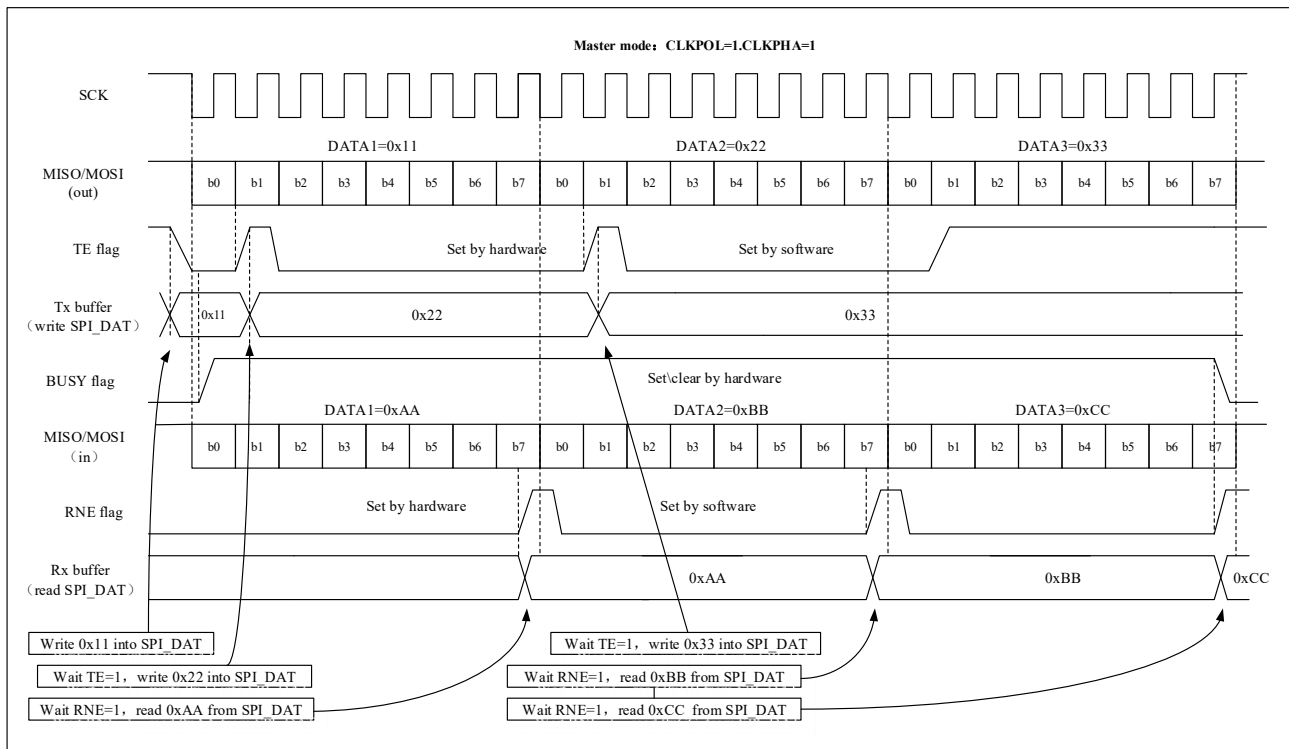
Master full duplex mode (SPI\_CTRL1.MSEL = 1, SPI\_CTRL1.BIDIRMODE = 0, SPI\_CTRL1.ROONLY = 0). After the first data is written to the SPI\_DAT register, the transmission will start. When the first bit of the data is transmitted, the data bytes are loaded from the data register into the shift register in parallel, and then according to the configuration of the SPI\_CTRL1.LSBFF bit, the data bits follow the MSB or LSB order is serially shifted to the MOSI pin. At the same time, the data received on the MISO pin is serially shifted into the shift register in the same order and then loaded into the

SPI\_DAT register in parallel. The software operation process is as follows:

1. Set SPI\_CTRL1.SPIEN = 1, enable SPI module.
2. Write the first data to be sent into SPI\_DAT register (this operation will clear SPI\_STS.TE bit).
3. Wait for SPI\_STS.TE bit to be set to '1', and write the second data to be sent into SPI\_DAT. Wait for SPI\_STS.RNE bit to be set to '1', read SPI\_DAT to get the first received data, and the SPI\_STS.RNE bit will be cleared by hardware while reading SPI\_DAT. Repeat the above operation, transmitting subsequent data and receiving n-1 data at the same time;
4. Wait for SPI\_STS.RNE bit to be set to '1' to receive the last data;
5. Wait for SPI\_STS.TE to be set to '1', then wait for SPI\_STS.BUSY bit to be cleared and turn off SPI module.

The process of data transmitting and data receiving can also be implemented in the interrupt handler triggered by the rising edge of the SPI\_STS.RNE or SPI\_STS.TE flag.

Figure 20-5 Changes of TE/RNE/BUSY During Continuous Transmission in Master Full Duplex Mode



### 20.3.2.2 Master two-wire one-way transmit-only mode

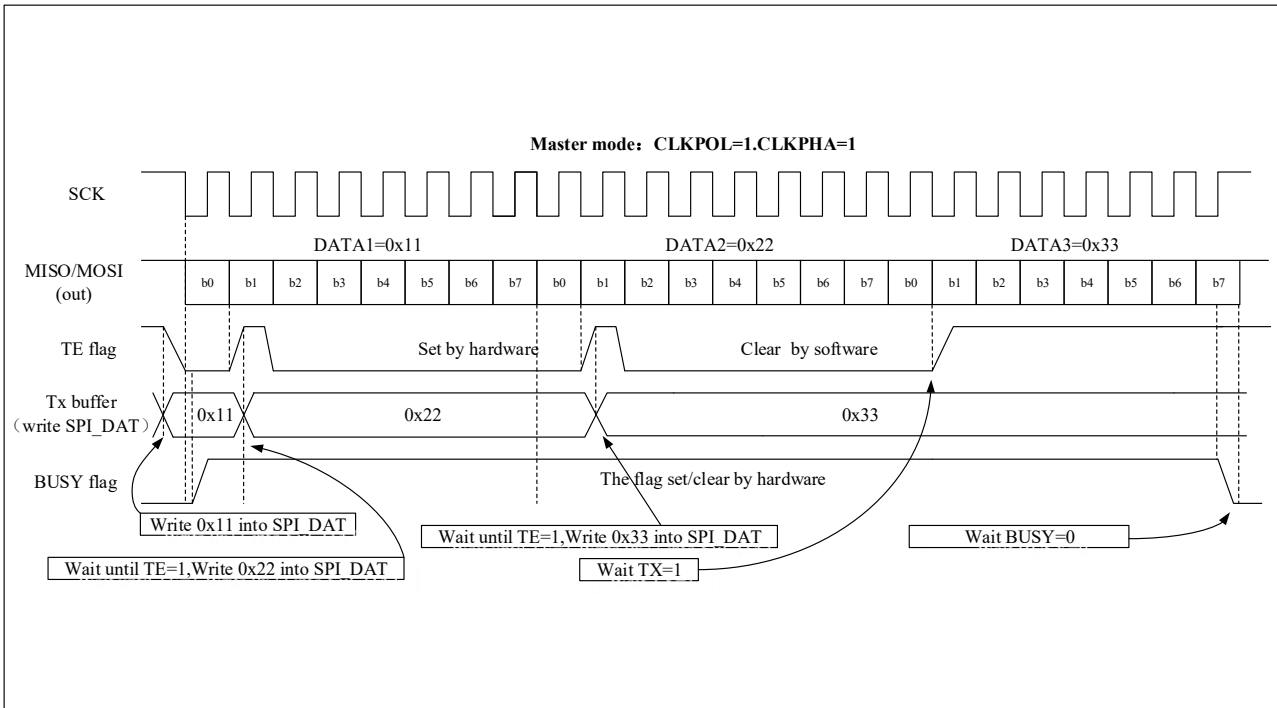
Master two-wire one-way transmit-only mode (SPI\_CTRL1.MSEL = 1, SPI\_CTRL1.BIDIRMODE = 0, SPI\_CTRL1.ONLY = 0). Master two-wire one-way transmit-only mode is similar to master full-duplex mode. The difference is that this mode will not read the received data, so the SPI\_STS.OVER bit will be set to '1', and the software will ignore it. The software operation process is as follows:

1. Enable SPI module, set SPI\_CTRL1.SPIEN = 1.
2. Write the first data to be sent into SPI\_DAT register (this operation will clear SPI\_STS.TE bit).

3. Wait for SPI\_STS.TE bit to be set to '1', and write the second data to be sent into SPI\_DAT. Repeat this operation to transmit subsequent data;
4. After writing the last data to SPI\_DAT, wait for SPI\_STS.TE bit to set '1'; then wait for SPI\_STS.BUSY bit to be cleared to complete the transmission of all data.

The process of data transmitting can also be implemented in the interrupt handler triggered by the rising edge of the TE flag.

**Figure 20-6 Changes of TE/BUSY During The Host Transmits Continuously in One-way Transmit-only Mode**



**20.3.2.3 Master two-wire one-way receive-only mode**

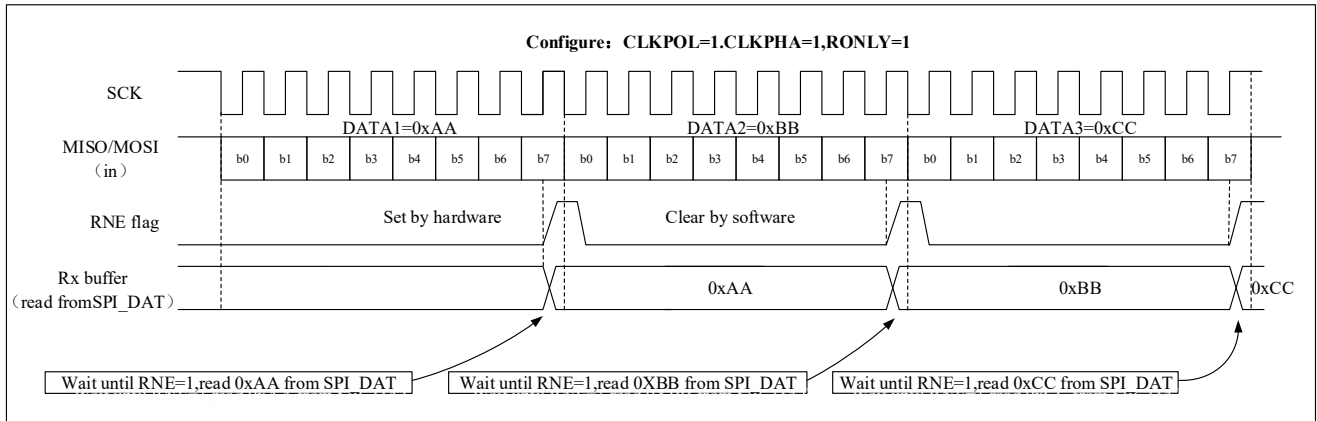
Master two-wire one-way receive-only mode (SPI\_CTRL1.MSEL = 1, SPI\_CTRL1.BIDIRMODE = 0, SPI\_CTRL1.ONLY = 1). When SPI\_CTRL1.SPIEN = 1, the receiving process starts. The data bits from the MISO pin are sequentially shifted into the shift register and then loaded into the SPI\_DAT register (receive buffer) in parallel. The software operation process is as follows:

1. Enable the receive-only mode (SPI\_CTRL1.ONLY = 1).
2. Enable SPI module, set SPI\_CTRL1.SPIEN = 1: in master mode, SCLK clock signal is generated immediately, and serial data is continuously received before SPI is turned off (SPI\_CTRL1.SPIEN = 0); in slave mode, serial data is continuously received when the SPI master device pulls low the NSS signal and generates SCLK clock.
3. Wait for SPI\_STS.RNE bit to be set to '1', read the SPI\_DAT register to get the received data, and the SPI\_STS.RNE bit will be cleared by hardware while reading SPI\_DAT register. Repeat this operation to receive all data.

The process of data receiving can also be implemented in the interrupt handler triggered by the rising edge of the RNE flag.

**Figure 20-7 Changes of RNE During Continuous Transmission Occurs in Receive-only Mode (BIDIRMODE = 0 and**

RONLY = 1)



**20.3.2.4 Master one-wire bidirectional transmit mode**

Master one-wire bidirectional transmit mode (SPI\_CTRL1.MSEL = 1, SPI\_CTRL1.BIDIRMODE = 1, SPI\_CTRL1.BIDIROEN = 1, SPI\_CTRL1.ONLY = 0). After the data is written to the SPI\_DAT register (transmit buffer), the transmission process starts. This mode does not receive data. At the same time as the first data bit is transmitted, the data to be sent is loaded into the shift register in parallel, and then according to the configuration of the SPI\_CTRL1.LSBFF bit, the SPI serially shifts the data bits to the MOSI pin in MSB or LSB order.

The software operation flow of the master one-wire bidirectional transmit mode is the same as that of the transmit-only mode.

**20.3.2.5 Master one-wire bidirectional receive mode**

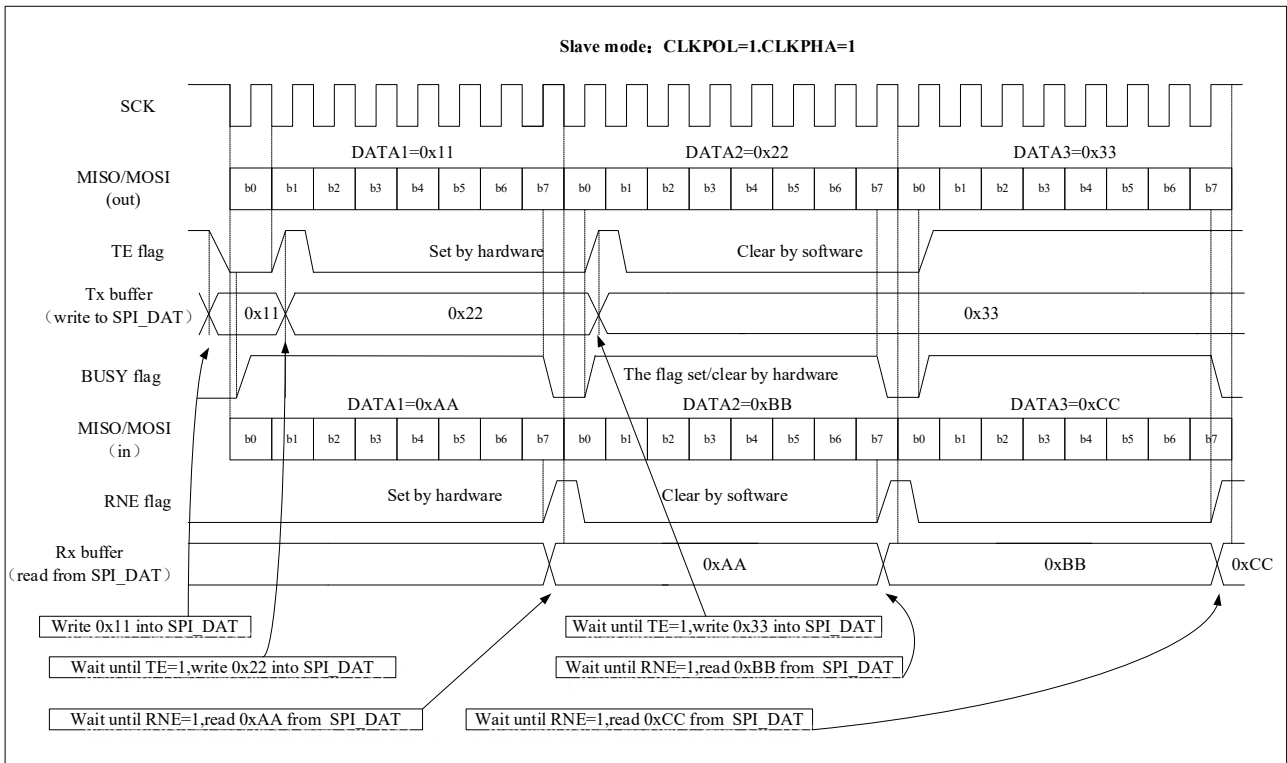
Master one-wire bidirectional receive mode (SPI\_CTRL1.MSEL = 1, SPI\_CTRL1.BIDIRMODE = 1, SPI\_CTRL1.BIDIROEN = 0, SPI\_CTRL1.ONLY = 0). When SPI\_CTRL1.SPIEN = 1, the receiving process starts. There is no data output in this mode, the received data bits are sequentially and serially shifted into the shift register, and then loaded into the SPI\_DAT register (receive buffer) in parallel.

The software operation flow of the master one-wire bidirectional receive mode is the same as that of the receive-only mode.

**20.3.2.6 Slave full duplex mode**

Slave full duplex mode (SPI\_CTRL1.MSEL = 0, SPI\_CTRL1.BIDIRMODE = 0 and SPI\_CTRL1.ONLY = 0). The data transfer process begins when the slave device receives the first clock edge. Before the master starts data transfer, software must ensure that the data to be transmitted is written to the SPI\_DAT register.

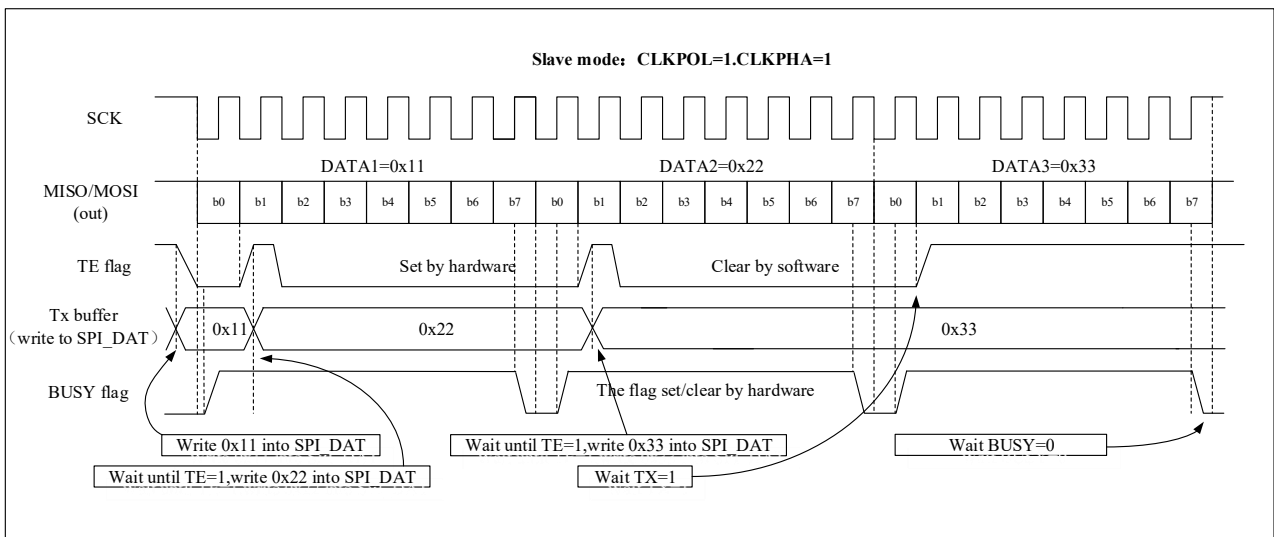
Figure 20-8 Changes of TE/RNE/BUSY During The Slave Is Continuously Transmitting in Full Duplex Mode



20.3.2.7 Slave two-wire one-way transmit-only mode

Slave two-wire one-way transmit-only mode (SPI\_CTRL1.MSEL = 0, SPI\_CTRL1.BIDIRMODE = 0 and SPI\_CTRL1.ROONLY = 0).

Figure 20-9 Changes of TE/BUSY During Continuous Transmission in Slave Unidirectional Transmit-only Mode



20.3.2.8 Slave two-wire one-way receive-only mode

Slave two-wire one-way receive-only mode (SPI\_CTRL1.MSEL = 0, SPI\_CTRL1.BIDIRMODE = 0 and SPI\_CTRL1.ROONLY = 1).The data receiving process begins when the slave device receives the clock signal and the first

data bit from the MOSI pin. The received data bits are sequentially and consecutively shifted serially into an shift register and then loaded into the SPI\_DAT register (receive buffer) in parallel.

#### 20.3.2.9 Slave one-wire bidirectional transmit mode

Slave one-wire bidirectional transmit mode (SPI\_CTRL1.MSEL = 0, SPI\_CTRL1.BIDIRMODE = 1 and SPI\_CTRL1.BIDIROEN = 1). When the slave device receives the first edge of the clock signal, the transmitting process starts. No data is received in this mode, and the software must ensure that the data to be transmitted has been written in the SPI\_DAT register before the SPI master device starts data transmission.

#### 20.3.2.10 Slave one-wire bidirectional receive mode

Slave one-wire bidirectional receive mode (SPI\_CTRL1.MSEL = 0, SPI\_CTRL1.BIDIRMODE = 1 and SPI\_CTRL1.BIDIROEN = 0). Data receiving begins when the slave device receives the first clock edge and a data bit from the MOSI pin. There is no data output in this mode, the received data bits are sequentially and consecutively shifted serially into an shift register, and then loaded into the SPI\_DAT register (receive buffer) in parallel.

*Note: The software operation process of the slave can refer to the master.*

#### 20.3.2.11 SPI initialization process

1. The baud rate of serial clock is configured by the SPI\_CTRL1.BR[2:0] bits (this step is ignored if it is operating in slave mode).
2. Select SPI\_CTRL1.CLKPOL bit and SPI\_CTRL1.CLKPHA bit to configure the phase relationship between data transmission and serial clock (refer to Figure 20-4).
3. Set SPI\_CTRL1.DATFF bit to define 8-bit or 16-bit data frame format.
4. Configure the SPI\_CTRL1.LSBFF bit to configure the frame format.
5. Configure the NSS mode as described above for the NSS function.
6. Operate mode is configured by SPI\_CTRL1.MSEL bit, SPI\_CTRL1.BIDIRMODE bit, SPI\_CTRL1.BIDIROEN bit and SPI\_CTRL1.ONLY bit.
7. Set the SPI\_CTRL1.SPIEN = 1 to enable SPI.

#### 20.3.2.12 Basic transmit and receive process

When SPI transmits a data frame, it first loads the data frame from the data buffer into the shift register, and then starts to transmit the loaded data. When the data is transferred from the transmit buffer to the shift register, the transmit buffer empty flag is set (SPI\_STS.TE = 1), and the next data can be loaded into the transmit buffer; if the TEINTEN bit is set (SPI\_CTRL2.TEINTEN = 1), an interrupt will be triggered; writing data to the SPI\_DAT register will clear the SPI\_STS.TE bit.

At the last edge of the sampling clock, when the data is transferred from the shift register to the receive buffer, the receive buffer non-empty flag is set (SPI\_STS.RNE = 1), at this time the data is ready and can be read from the SPI\_DAT register; if the receive buffer non-empty interrupt is enabled (SPI\_CTRL2.RNEINTEN = 1), an interrupt will be triggered; the SPI\_STS.RNE bit can be cleared by reading the SPI\_DAT register data.

In master mode, the transmitting process starts when data is written to the transmit buffer. If the next data has been written into the SPI\_DAT register before the current data frame transmitting is completed, the continuous transmitting function

can be achieved.

In slave mode, the NSS pin is low, and when the first clock edge arrives, the transmission process begins. In order to avoid accidental data transmission, software must write data to the transmit buffer before data transmission (it is recommended to enable the SPI module before the host sends the clock).

In some configurations, when the last data is sent, the BUSY flag (SPI\_STS.BUSY) can be used to wait for the end of the data transmitting.

**20.3.2.13 Continuous and discontinuous transmission**

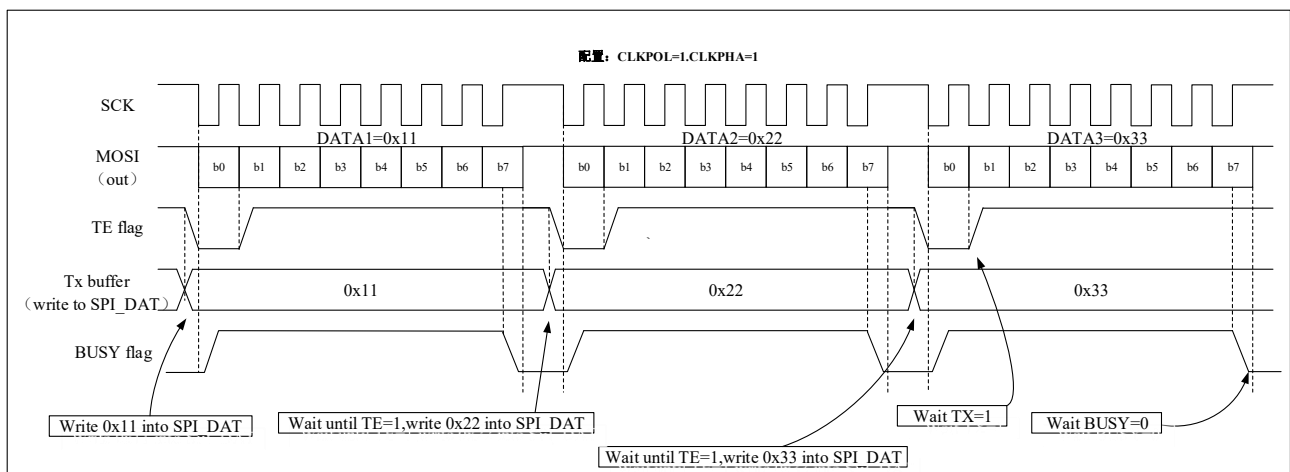
When transmitting data in master mode, if the software is fast enough to detect each TE (SPI\_STS.TE) rising edge (or TE interrupt), and the data is written to the SPI\_DAT register immediately before the end of the ongoing transmission. At this time, the SPI clock remains continuous between the transmission of data items, and the SPI\_STS.BUSY bit will not be cleared, continuous communication can be achieved.

If the software is not fast enough, it will result in discontinuous communication; in this case, the SPI\_STS.BUSY bit is cleared between the transmission of each data items (see figure below).

In master receive-only mode (SPI\_CTRL1.ROONLY = 1), communication is always continuous and the BUSY flag (SPI\_STS.BUSY) is always high.

In slave mode, the continuity of communication is determined by the SPI master device. However, even if the communication is continuous, the BUSY flag (SPI\_STS.BUSY) will be low for at least one SPI clock cycle between each data item (refer to Figure 20-4).

**Figure 20-10 Schematic Diagram of TE/BUSY Change When BIDIRMODE = 0 and RONLY = 0 Are Transmitted Discontinuously.**



**20.3.3 Status Flag**

The SPI\_STS register has 3 flag bits to monitor the status of the SPI:

**20.3.3.1 Transmit buffer empty flag bit (TE)**

When the transmit buffer is empty, the TE flag (SPI\_STS.TE) is set to 1, which means that new data can be written into the SPI\_DAT register. When the transmit buffer is not empty, the hardware will clear this flag to 0.

### 20.3.3.2 Receive buffer non-empty flag bit (RNE)

When the receive buffer is not empty, the RNE flag (SPI\_STS.RNE) is set to 1, so the user knows that there is data in the receive buffer. After reading the SPI\_DAT register, the hardware will set this flag to 0.

### 20.3.3.3 BUSY flag bit (BUSY)

When the transmission starts, the hardware sets the BUSY flag (SPI\_STS.BUSY) to 1, and after the transmission ends, the hardware sets the BUSY flag to 0.

Only when the device is in the master one-wire bidirectional receive mode, the BUSY flag (SPI\_STS.BUSY) will be set to 0 when the communication is in progress.

The BUSY flag (SPI\_STS.BUSY) will be cleared to 0 in the following cases:

- End of transmission (except for continuous communication in master mode);
- Turn off the SPI module (SPI\_CTRL1.SPIEN = 0);
- The master mode error occurs (SPI\_STS.MODERR = 1)

When the communication is discontinuous: the BUSY flag (SPI\_STS.BUSY) is cleared to '0' between the transmission of each data item.

When communication is continuous: in master mode, the BUSY flag (SPI\_STS.BUSY) remains high during the entire transfer process; In slave mode, the BUSY flag (SPI\_STS.BUSY) will be low for 1 SPI clock cycle between each data item transfer. So do not use the BUSY flag to handle the transmitting and receiving of each data item.

## 20.3.4 Turn off SPI

In order to turn off the SPI module, different operation modes require different operation steps.

### 20.3.4.1 Master or slave full duplex mode

1. Wait for the RNE flag (SPI\_STS.RNE) to be set to 1 and the last byte to be received;
2. Wait for the TE flag (SPI\_STS.TE) to be set to 1;
3. Wait for the BUSY flag (SPI\_STS.BUSY) to be cleared to 0;
4. Turn off the SPI module (SPI\_CTRL1.SPIEN = 0).

### 20.3.4.2 One-way transmit-only mode or bidirectional transmit mode for master or slave

1. After writing the last byte to the SPI\_DAT register, wait for the TE flag (SPI\_STS.TE) to be set to 1;
2. Wait for the BUSY flag (SPI\_STS.BUSY) to be cleared to 0;
3. Turn off the SPI module (SPI\_CTRL1.SPIEN = 0).

### 20.3.4.3 One-way receive-only mode or bidirectional receive mode for master

1. Wait for the penultimate RNE (SPI\_STS.RNE) to be set to 1;
2. Before closing the SPI module (SPI\_CTRL1.SPIEN = 0), wait for 1 SPI clock cycle (using software delay);
3. Wait for the last RNE (SPI\_STS.RNE) to be set before entering shutdown mode (or turning off the SPI module clock).



#### 20.3.4.4 One-way receive-only mode or bidirectional receive mode for slave

1. The SPI module can be turned off at any time ( $\text{SPI\_CTRL1.SPIEN} = 0$ ), and after the current transfer is over, the SPI module will be turned off;
2. If you want to enter the SHUTDOWN mode, you must wait for the BUSY flag ( $\text{SPI\_STS.BUSY}$ ) to be set to 0 before entering the SHUTDOWN mode (or turn off the SPI module clock).

#### 20.3.5 SPI Communication Using DMA

Users can choose DMA for SPI data transfer, the application program can be released, and the system efficiency can be greatly improved.

When the transmit buffer DMA is enabled ( $\text{SPI\_CTRL2.TDMAEN} = 1$ ), each time the TE flag ( $\text{SPI\_STS.TE}$ ) bit is 1, a DMA request will be generated, and the DMA will automatically write the data to the SPI\_DAT register, which will clear the TE flag ( $\text{SPI\_STS.TE}$ ) bit. When the receive buffer DMA is enabled ( $\text{SPI\_CTRL2.RDMAEN} = 1$ ), each time the RNE flag ( $\text{SPI\_STS.RNE}$ ) bit is set to 1, a DMA request will be generated, and the DMA will automatically read the SPI\_DAT register, which will clear the RNE flag ( $\text{SPI\_STS.RNE}$ ) bit.

When the SPI is only used for transmitting data, only the transmit DMA channel of the SPI needs to be enabled ( $\text{SPI\_CTRL2.TDMAEN} = 1$ ).

When the SPI is only used for receiving data, only the receive DMA channel of the SPI needs to be enabled ( $\text{SPI\_CTRL2.RDMAEN} = 1$ ).

In transmit mode, after DMA has transmitted all the data ( $\text{DMA\_INTSTS.TXCF} = 1$ ), BUSY flag ( $\text{SPI\_STS.BUSY}$ ) can monitor to confirm whether SPI communication is over, which can avoid destroying the transmission of the last data when the SPI is turned off or enters the shutdown mode. Therefore, the software needs to wait for the TE flag ( $\text{SPI\_STS.TE}$ ) bit to be set to 1, and wait for the BUSY flag ( $\text{SPI\_STS.BUSY}$ ) bit to be set to 0.

Figure 20-11 Transmission Using DMA

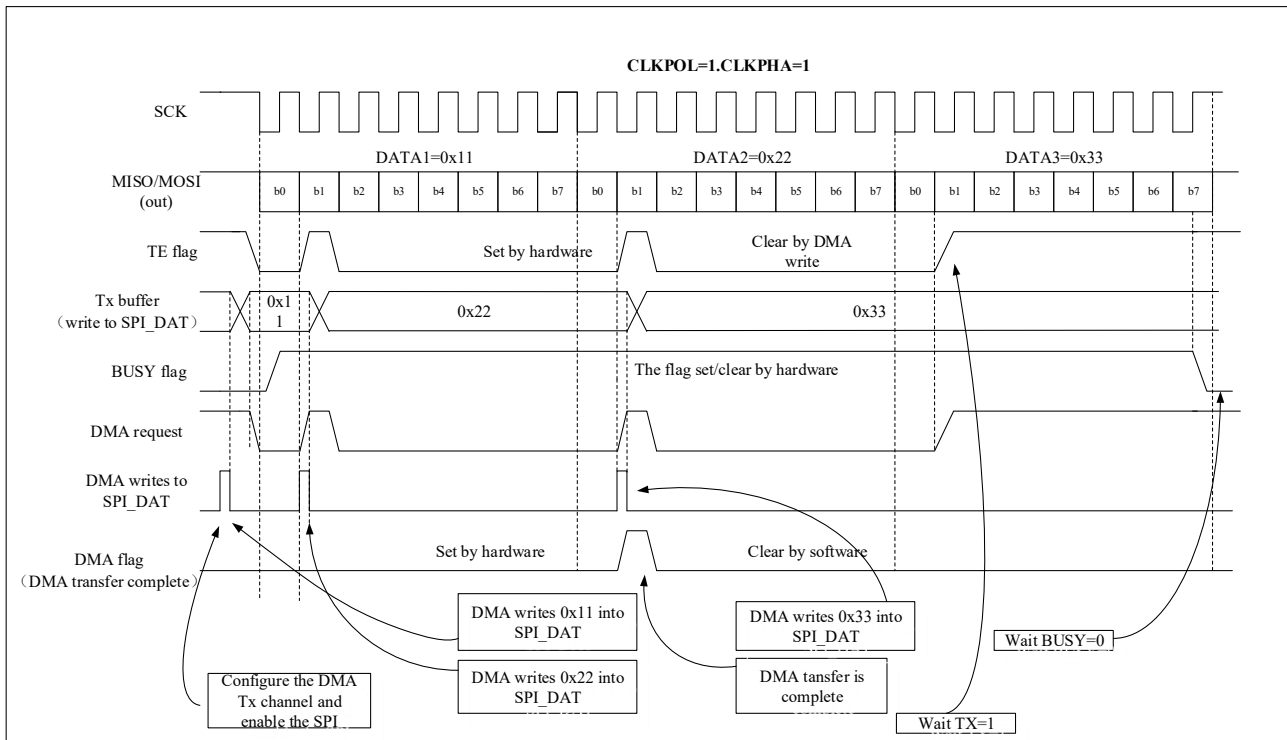
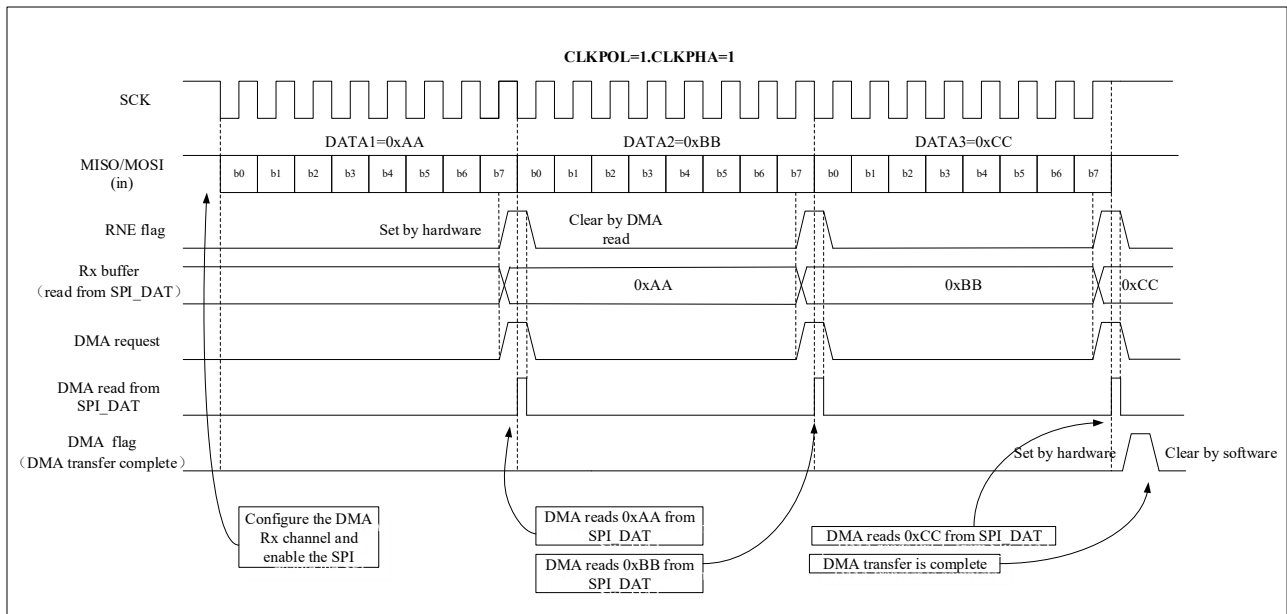


Figure 20-12 Reception Using DMA



### 20.3.6 CRC Calculation

SPI contains two independent CRC calculators for data transmitting and data receiving to ensure the correctness of data transmission. According to the transmitting and receiving data frame format, CRC adopts different calculation methods, the 8-bit data frame format adopts CRC8, and the 16-bit data frame format adopts CRC16. The polynomial used in the SPI

CRC calculation is set by the SPI\_CRCPOLY register, and the user enables the CRC calculation by setting the SPI\_CTRL1.CRCEN = 1.

In transmit mode, after the last data is written into the transmit buffer, set the SPI\_CTRL1.CRCNEXT = 1, which indicates that the hardware will start transmitting the CRC value (SPI\_CRCTDAT value) after transmitting the data. When the CRC is transmitted, the CRC calculation will stop.

In receive mode, after the penultimate data frame is received, set the SPI\_CTRL1.CRCNEXT = 1. The received CRC and SPI\_CRCDAT values are compared, if they are different, the SPI\_STS.CRCERR bit is set to 1. If the SPI\_CTRL2.ERRINTEN bit is set to 1, an interrupt will be triggered.

In order to keep the synchronization of the next CRC calculation result of the master-slave device, the user should clear the CRC value of the master-slave device. Setting the SPI\_CTRL1.CRCEN bit resets the SPI\_CRCDAT and SPI\_CRCTDAT registers. Take the following steps in order: SPI\_CTRL1.SPIEN = 0; SPI\_CTRL1.CRCEN = 0; SPI\_CTRL1.CRCEN = 1; SPI\_CTRL1.SPIEN = 1.

Most importantly, when the SPI is configured in slave mode and CRC is enabled, as long as there is a clock pulse on SCLK pin, the CRC calculation will still be performed even if the NSS pin is high. This situation is common when the master device communicates with multiple slave devices alternately, so it is necessary to avoid CRC misoperation.

When the SPI hardware CRC check is enabled (SPI\_CTRL1.CRCEN = 1) and the DMA is enabled, the hardware automatically completes the transmission and reception of CRC bytes when the communication ends.

### 20.3.7 Error Flag

#### 20.3.7.1 Master mode failure error (MODERR)

The following two conditions will cause the master mode failure error:

- NSS pin hardware management mode, the master device NSS pin is pulled low;
- NSS pin software management mode, the SPI\_CTRL1.SSEL bit is set to 0.

When a master mode failure error occurs, the SPI\_STS.MODERR bit is set to 1. An interrupt is triggered if the user enables the corresponding interrupt (SPI\_CTRL2.ERRINTEN=1). The SPI\_CTRL1.SPIEN bit and SPI\_CTRL1.MSEL bit will be write-protected and both are cleared by hardware. SPI is turned off and forced into slave mode.

Software performs a read or write operation to the SPI\_STS register, and then writes to the SPI\_CTRL1 register to clear the SPI\_STS.MODERR bit (in multi-master mode, the master's NSS pin must be pulled high first).

Normally, the SPI\_STS.MODERR bit of the slave device cannot be set to 1. However, in a multi-master configuration, the slave's SPI\_STS.MODERR bit may be set to 1. In this case, the SPI\_STS.MODERR bit indicates that there is a multi-master collision. The interrupt routine can perform a reset or return to the default state to recover from an error state.

#### 20.3.7.2 Overflow error (OVER)

When the SPI\_STS.RNE bit is set to 1, but there is still data received into the receive buffer, an overflow error will occur. At this time, the overflow flag SPI\_STS.OVER bit is set to 1. An interrupt is triggered if the user enables the corresponding interrupt (SPI\_CTRL2.ERRINTEN = 1). All received data is lost, and the SPI\_DAT register retains only previously unread data.

Read the SPI\_DAT register and the SPI\_STS register in turn to clear the SPI\_STS.OVER bit

### 20.3.7.3 CRC error (CRCERR)

The CRC error flag is used to check the validity of the received data. A CRC error occurs when the received CRC value does not match the SPI\_CRCRDAT value. At this time, the SPI\_STS.CRCERR flag bit is set to '1', and an interrupt will be triggered if the user enables the corresponding interrupt (SPI\_CTRL2.ERRINTEN = 1).

## 20.3.8 SPI Interrupt

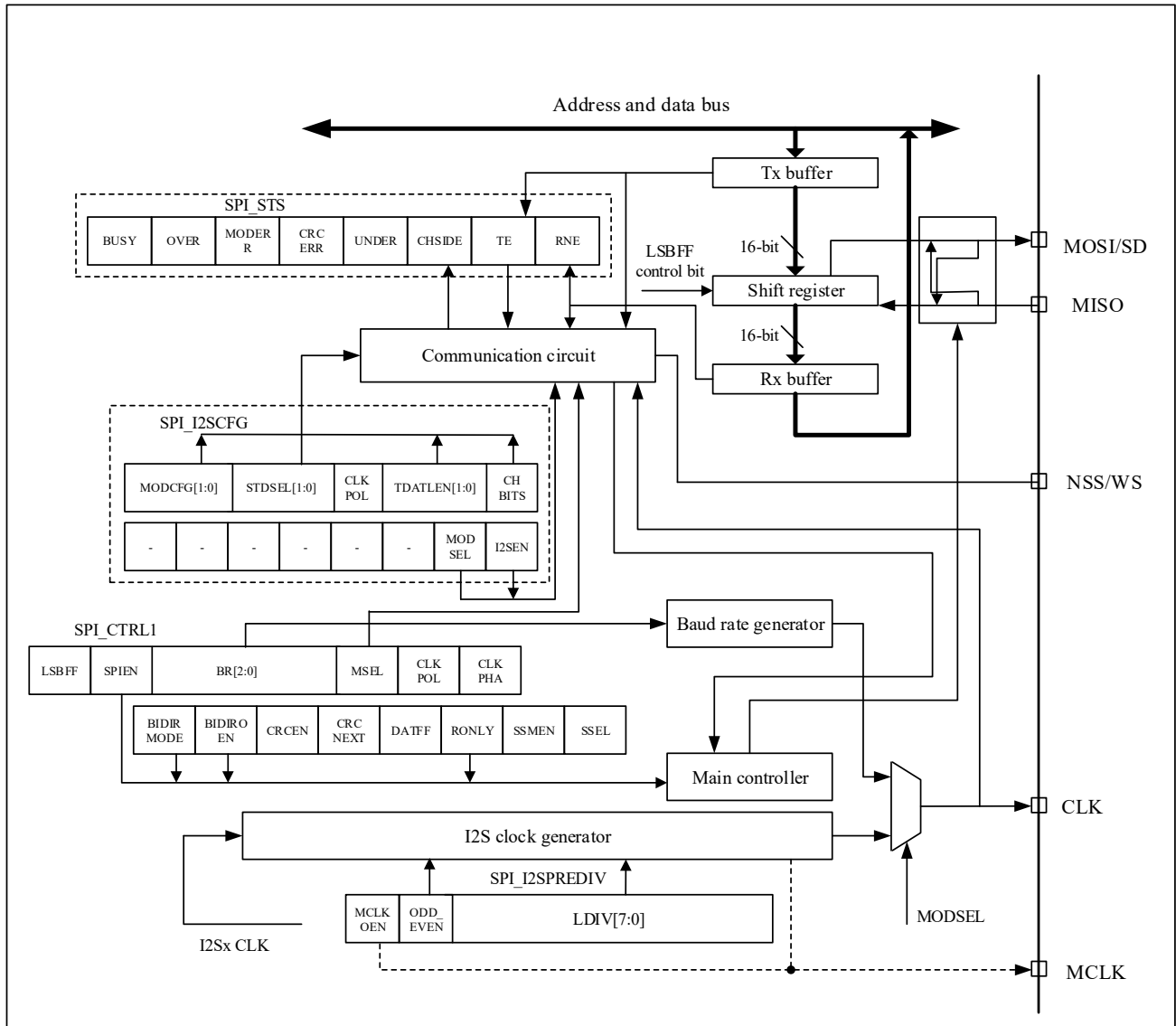
**Table 20-1 SPI Interrupt Request**

| Interrupt Event               | Event Flag Bit | Enable Control Bit |
|-------------------------------|----------------|--------------------|
| Transmit buffer empty flag    | TE             | TEINTEN            |
| Receive buffer non empty flag | RNE            | RNEINTEN           |
| Master mode failure event     | MODERR         | ERRINTEN           |
| Overflow error                | OVER           |                    |
| CRC error flag                | CRCERR         |                    |

## 20.4 I<sup>2</sup>S Function Description

The block diagram of I<sup>2</sup>S is shown in the figure below:

Figure 20-13 I<sup>2</sup>S Block Diagram



The I<sup>2</sup>S interface uses the same pins, flags and interrupts as the SPI interface. Setting the SPI\_I2SCFG.MODSEL = 1 selects the I<sup>2</sup>S audio interface.

I<sup>2</sup>S has a total of 4 pins, 3 of which are shared with SPI:

- CLK: Serial clock (shared with SCLK pin), CLK generates a pulse every time 1-bit audio data is sent.
- SD: Serial data (shared with MOSI pin), used for data transmit and receive;
- WS: Channel selection (shared with NSS pin), used as data control signal output in master mode, and used as input in slave mode;

- MCLK: master clock (independent mapping, optional), output  $256 \times F_s$  clock signal to ensure better synchronization between systems.

*Note:  $F_s$  is the sampling frequency of audio signal*

In master mode, I<sup>2</sup>S uses its own clock generator to generate clock signals for communication, and this clock generator is also the clock source of the master clock output (SPI\_I2SPREDIV.MCLKOEN = 1, the master clock output is enabled).

### 20.4.1 Supported Audio Protocols

Four audio standards can be selected by setting the SPI\_I2SCFG.STDSEL[1:0] bits:

- I<sup>2</sup>S Philips standard
- MSB alignment standard
- LSB alignment standard
- PCM standard

The audio data of the left channel and the right channel are usually time-division multiplexed, and the left channel always transmits data before the right channel. By checking the SPI\_STS.CHSIDE bit, the user can distinguish which channel the received data belongs to. However, in the PCM audio standard, the CHSIDE bit has no meaning.

By setting the SPI\_I2SCFG.TDATLEN bits, the user can set the length of the data to be transmitted, and set the data bit width of the channel by setting the SPI\_I2SCFG.CHBITS bits. There are 4 data formats for transmitting data as follows:

- 16-bit data is packed into 16-bit data frame
- 16-bit data is packed into a 32-bit data frame (the first 16 bits are meaningful data, and the last 16 bits are set to 0 by hardware)
- 24-bit data is packed into 32-bit data frame (the first 24-bit data is meaningful data, and the latter 8-bit data is set to 0 by hardware)
- 32-bit data is packed into 32-bit data frame

I<sup>2</sup>S uses the same SPI\_DAT register as SPI to transmit and receive 16-bit wide data. If I<sup>2</sup>S needs to transmit or receive 24-bit or 32-bit wide data, the CPU needs to read or write the SPI\_DAT register twice. On the other hand, when I<sup>2</sup>S transmits or receives 16-bit wide data, the CPU only needs to read or write the SPI\_DAT register once.

Regardless of which data format and communication standard is used, I<sup>2</sup>S always transmits the most significant bit (MSB) first.

#### 20.4.1.1 I<sup>2</sup>S Philips standard

Using the I<sup>2</sup>S Philips standard, the device that transmits data changes the data on the falling edge of the clock, and the device that receives data samples the data on the rising edge of the clock. The WS signal should be valid one clock before the first data bit is transmitted and will change on the falling edge of the clock signal.

Figure 20-14 I<sup>2</sup>S Philips Protocol Waveform (16/32-bit Full Precision, CLKPOL = 0)

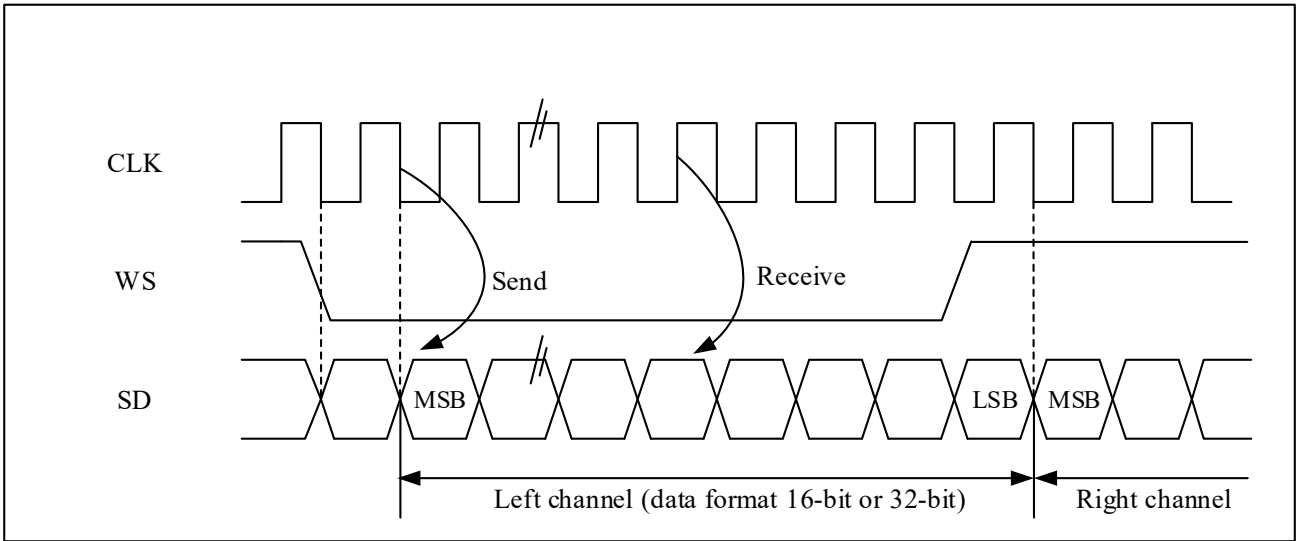
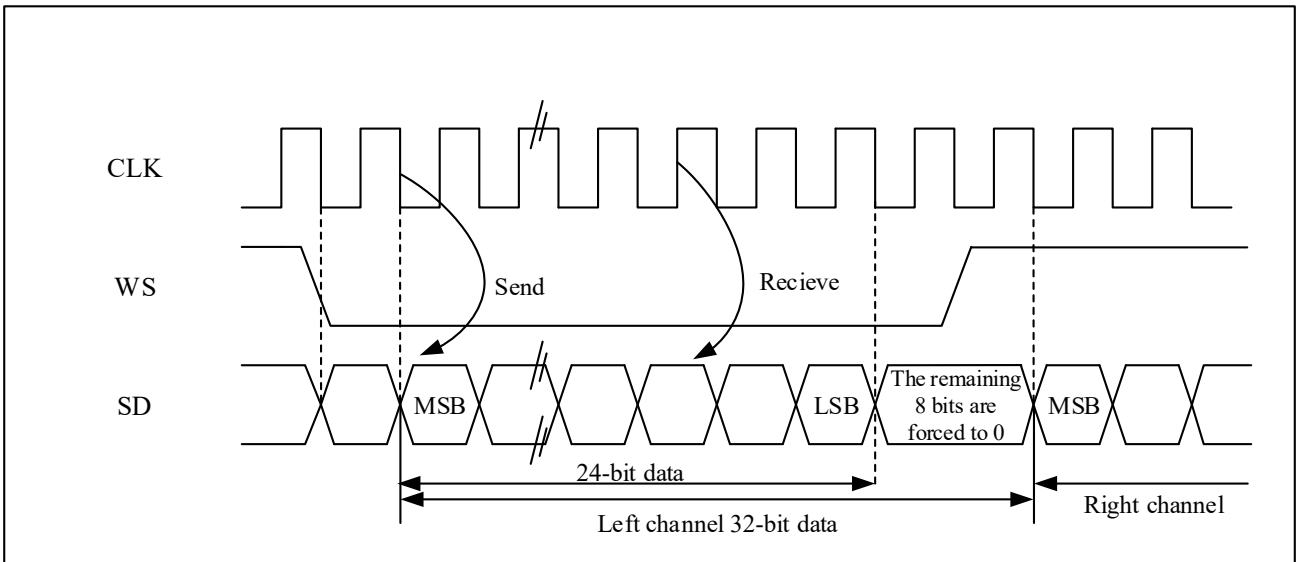
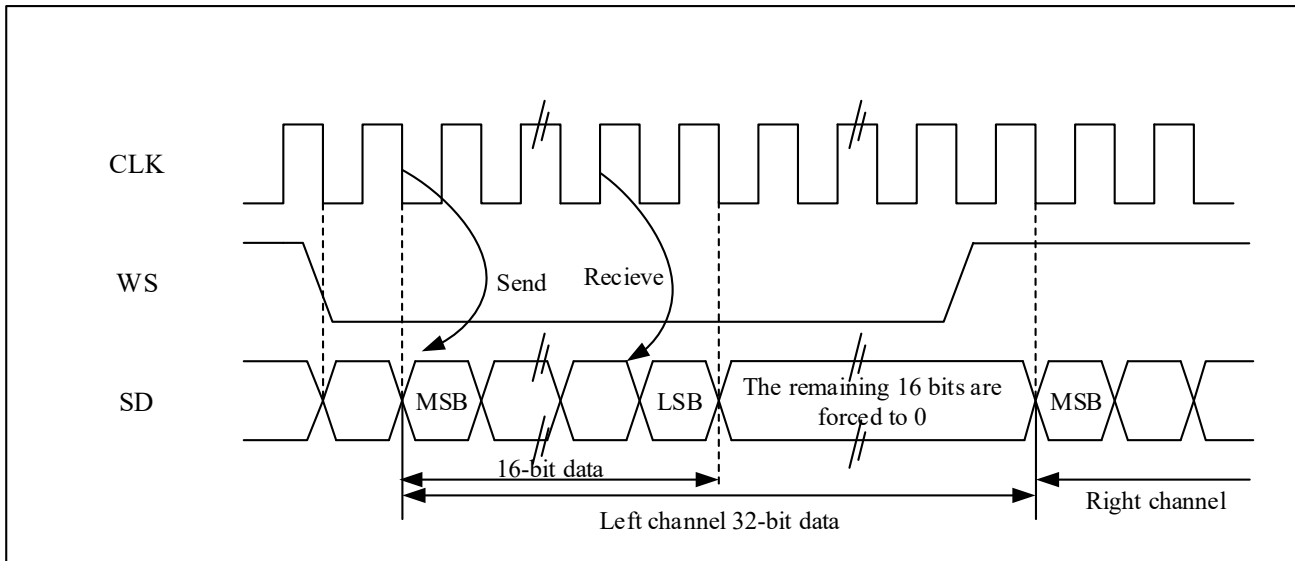


Figure 20-15 I<sup>2</sup>S Philips Protocol Standard Waveform (24-bit Frame, CLKPOL = 0)



If the 24-bit data needs to be packaged into 32-bit data frame format, the CPU needs to read or write the SPI\_DAT register twice during each frame of data transmission. For example, if the user transmits 24-bit data 0x95AA66, the CPU will first write 0x95AA into the SPI\_DAT register, and then write 0x66XX into the SPI\_DAT register (only the upper 8-bit data is valid, the lower 8-bit data is meaningless and can be any value); if the user receives 24-bit data 0x95AA66, the CPU will first read the SPI\_DAT register to get 0x95AA, and then read the SPI\_DAT register to get 0x6600 (only the upper 8-bit data is valid, and the lower 8-bit data is always 0).

Figure 20-16 I<sup>2</sup>S Philips Protocol Standard Waveform (16-bit Extended to 32-bit Packet Frame, CLKPOL = 0)



If 16-bit data needs to be packed into 32-bit data frame format, the CPU only needs to read or write the SPI\_DAT register once for each frame of data transmission. The lower 16 bits of data for expansion to 32 bits are always set to 0x0000. For example, if the user transmits or receives 16-bit data 0x89C1 (extended to 32-bit data is 0x89C10000). In the process of transmitting data, the upper 16-bit half word (0x89C1) needs to be written into the SPI\_DAT register; the user can write new data until the SPI\_STS.TE bit is set. An interrupt is triggered if the user enables the corresponding interrupt. The transmitting is performed by hardware, even if the last 16 bits (0x0000) are not sent, the hardware will set the TE (SPI\_STS.TE) bit to 1 and the corresponding interrupt will be triggered. In the process of receiving data, the RNE flag (SPI\_STS.RNE) will be set to 1 after each time the device receives the upper 16-bit halfword (0x89C1). An interrupt is triggered if the user enables the corresponding interrupt. In this way, there is more time between 2 reads and writes, which can prevent underflow or overflow from happening.

#### 20.4.1.2 MSB alignment standard

In the MSB alignment standard, the device transmitting the data will change the data on the falling edge of the clock, and the device receiving the data will sample the data on the rising edge of the clock. The WS signal and the first data bit are generated simultaneously.

The standard data receiving and transmitting processing mode is the same as I<sup>2</sup>S Philips standard.



Figure 20-17 The MSB Is Aligned with 16-bit or 32-bit Full Precision, CLKPOL = 0.

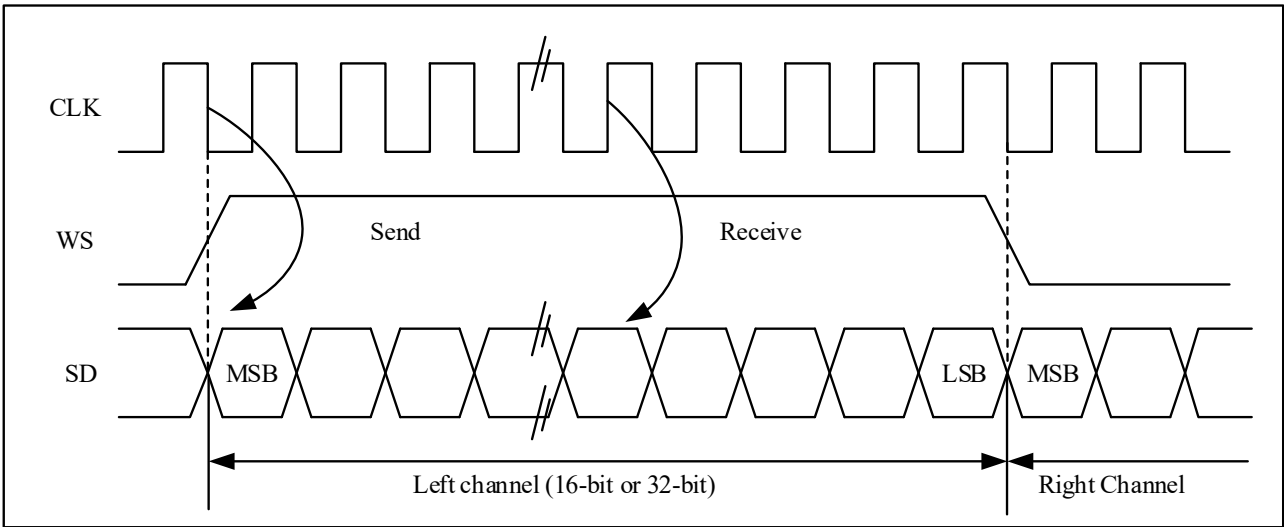


Figure 20-18 MSB Aligns 24-bit Data, CLKPOL = 0

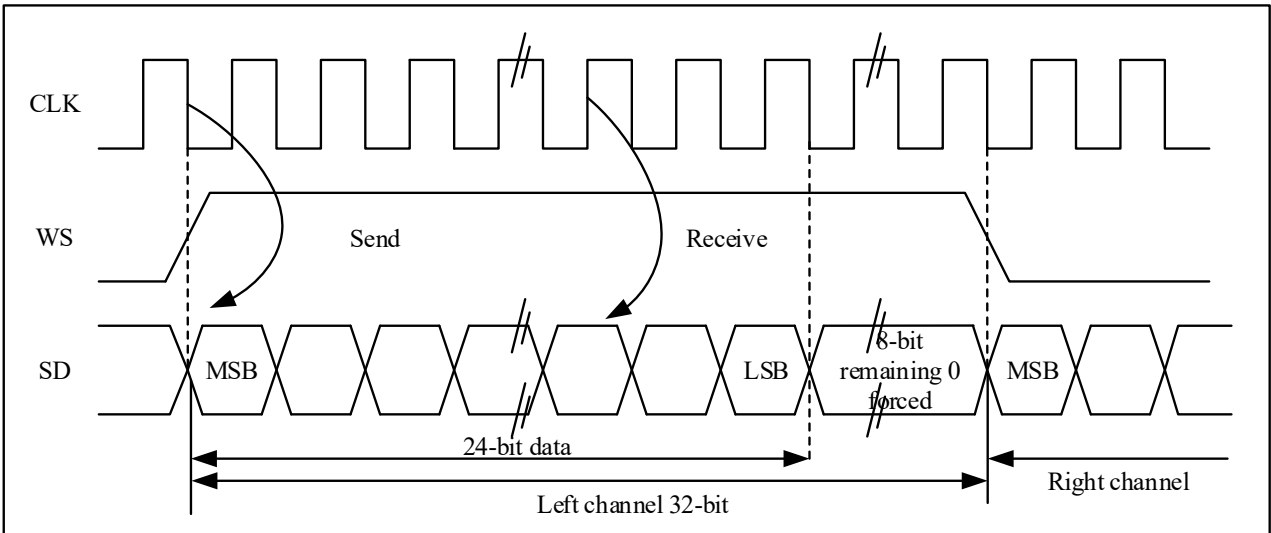
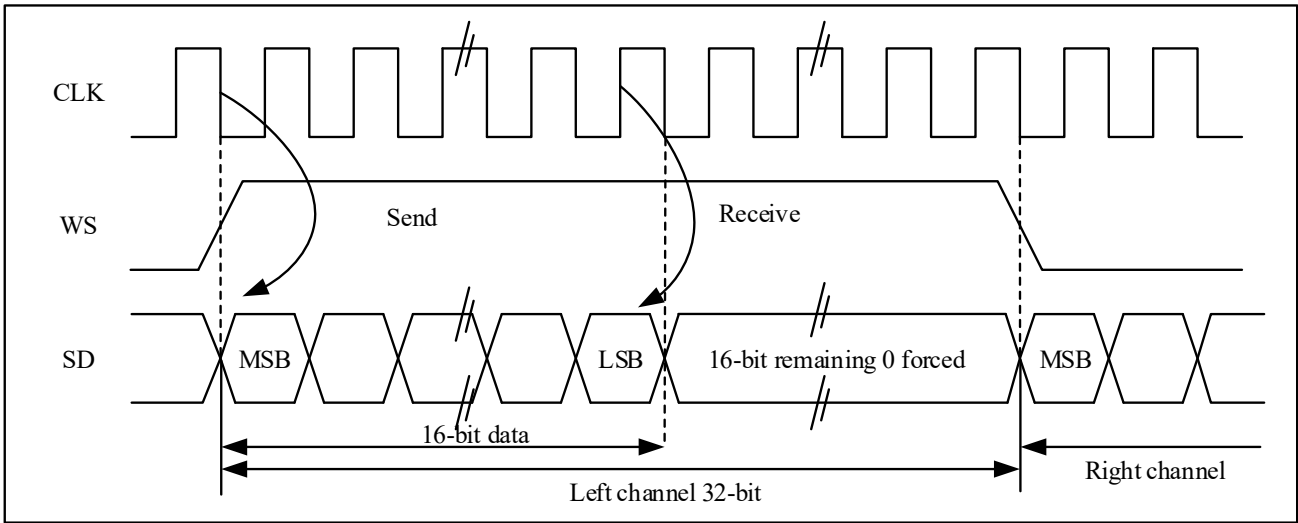


Figure 20-19 MSB-aligned 16-bit Data Is Extended to 32-bit Packet Frame, CLKPOL = 0



**20.4.1.3 LSB alignment standard**

In 16-bit or 32-bit full-precision frame format, LSB alignment standard is the same as MSB alignment standard.

Figure 20-20 LSB Alignment 16-bit or 32-bit Full Precision, CLKPOL = 0

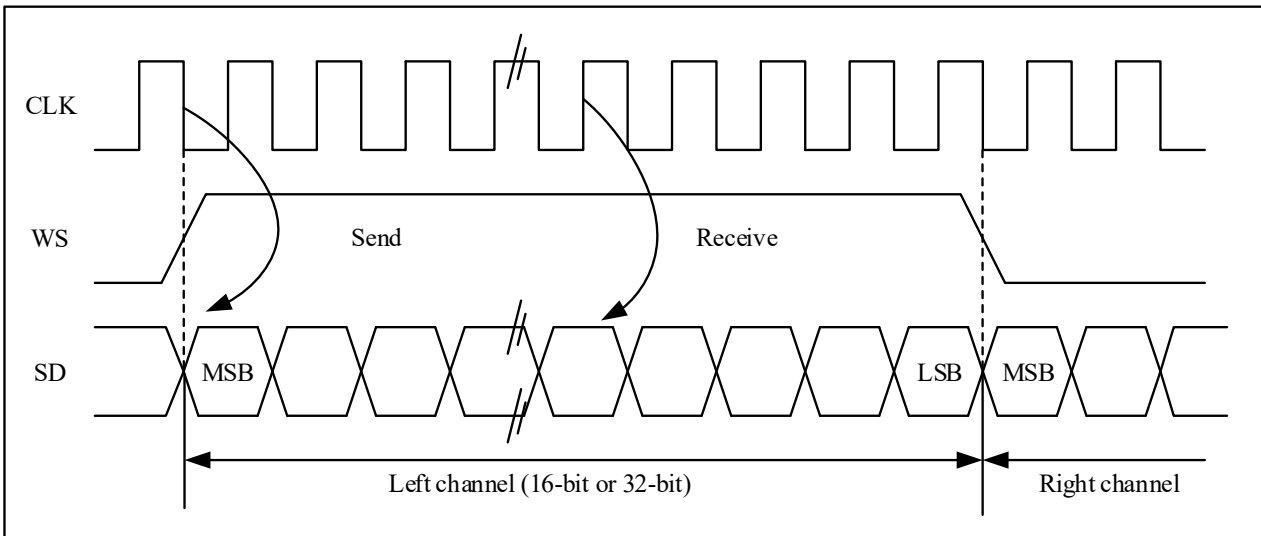
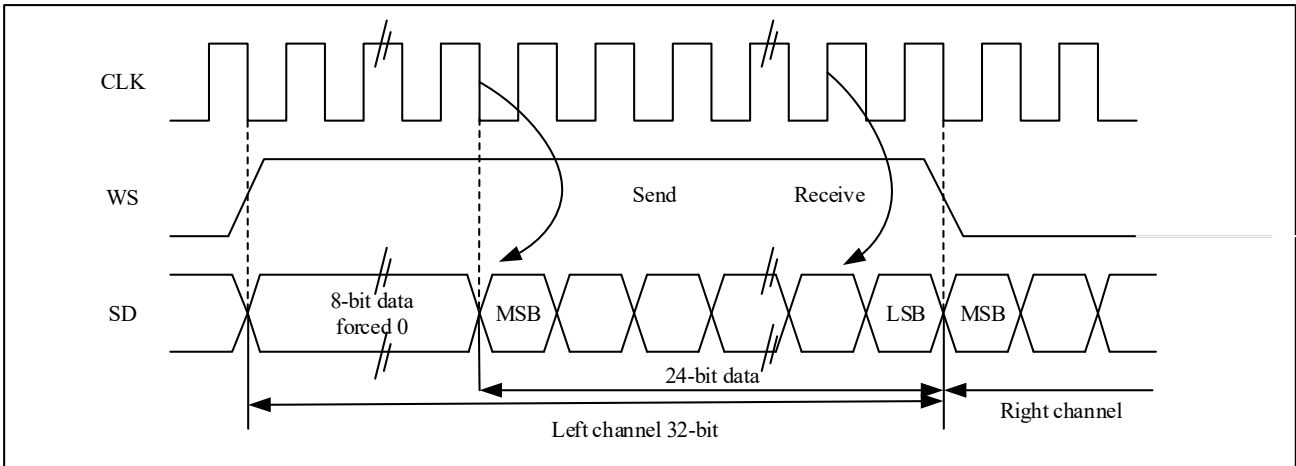
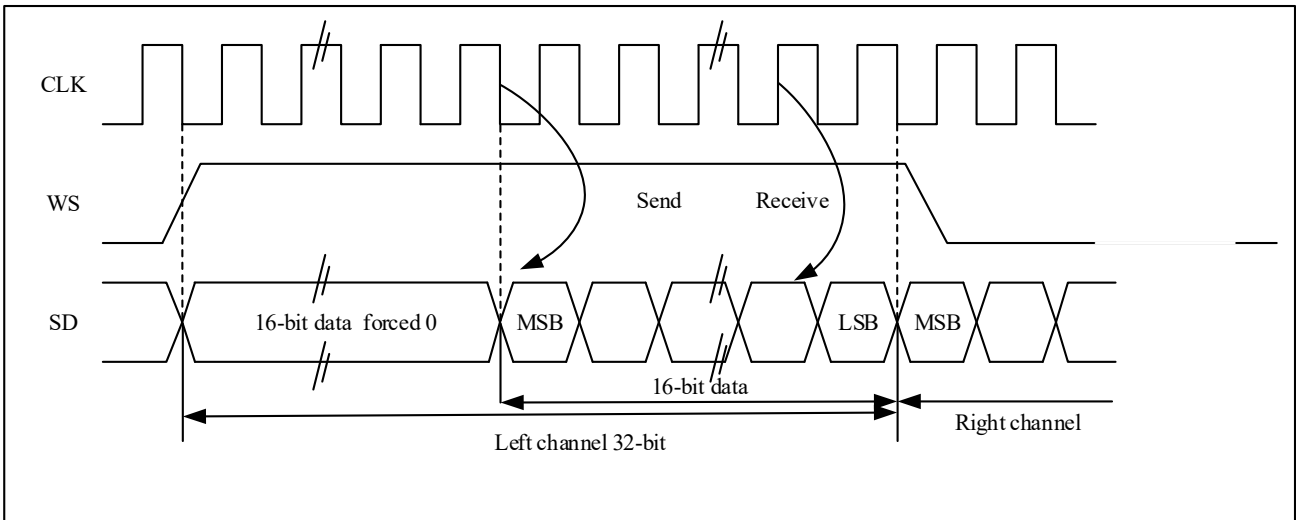


Figure 20-21 LSB Aligns 24-bit Data, CLKPOL = 0



If the 24-bit data needs to be packed into the 32-bit data frame format, the CPU needs to read or write the SPI\_DAT register twice during each frame of data transmission. For example, if the user transmits 24-bit data 0x95AA66, the CPU will first write 0xXX95 (only the lower 8-bit data is valid, the upper 8-bit data is meaningless and can be any value) into the SPI\_DAT register, and then write 0xAA66 into the SPI\_DAT register. If the user receives 24-bit data 0x95AA66, the CPU will first read the SPI\_DAT register to get 0x0095 (only the lower 8 bits are valid, the upper 8 bits are always 0), and then read the SPI\_DAT register to get 0xAA66.

Figure 20-22 LSB Aligned 16-bit Data Is Extended to 32-Bit Packet Frame, CLKPOL = 0



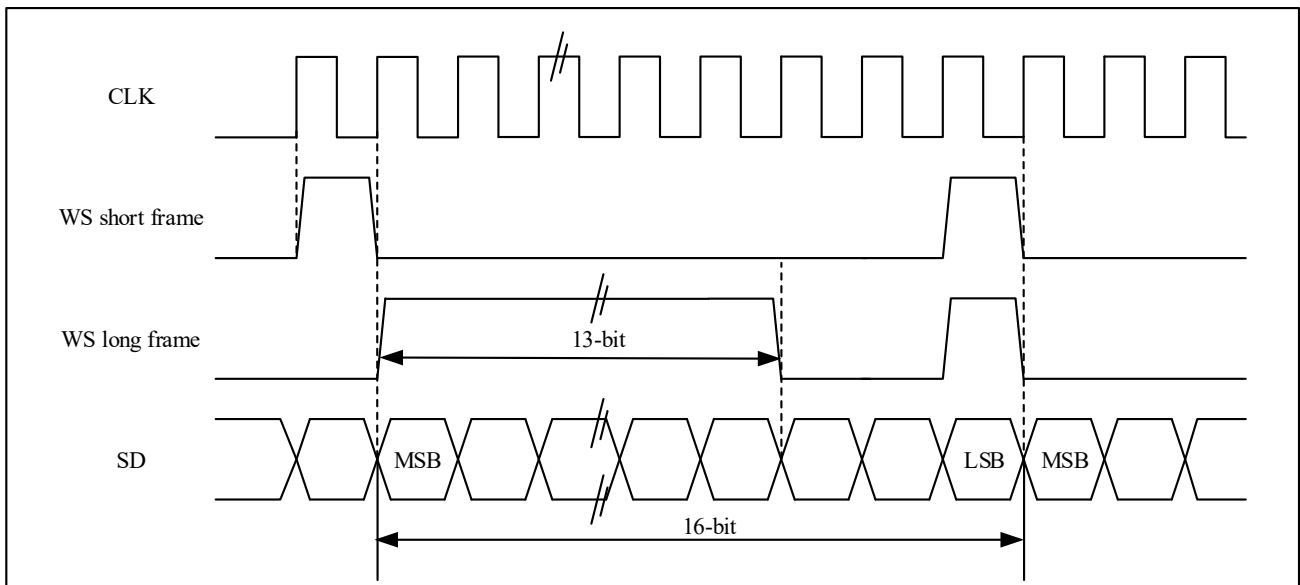
If the 16-bit data needs to be packaged into a 32-bit data frame format, the CPU only needs to read or write the SPI\_DAT register once for each frame of data transmission. The upper 16 bits of extended to 32 bits data are set to 0x0000 by hardware, if the user transmits or receives 16-bit data 0x89C1 (extended to 32-bit data is 0x000089C1). In the process of transmitting data, the upper 16-bit halfword (0x0000) needs to be written to the SPI\_DAT register first; once the valid data starts to be transmitted, the next TE (SPI\_STS.TE) event will be generated. In the process of receiving data, once the device receives valid data, the RNE (SPI\_STS.RNE) event will be generated. In this way, there is more time between 2 reads and writes, which can prevent underflow or overflow from happening.

**20.4.1.4 PCM standard**

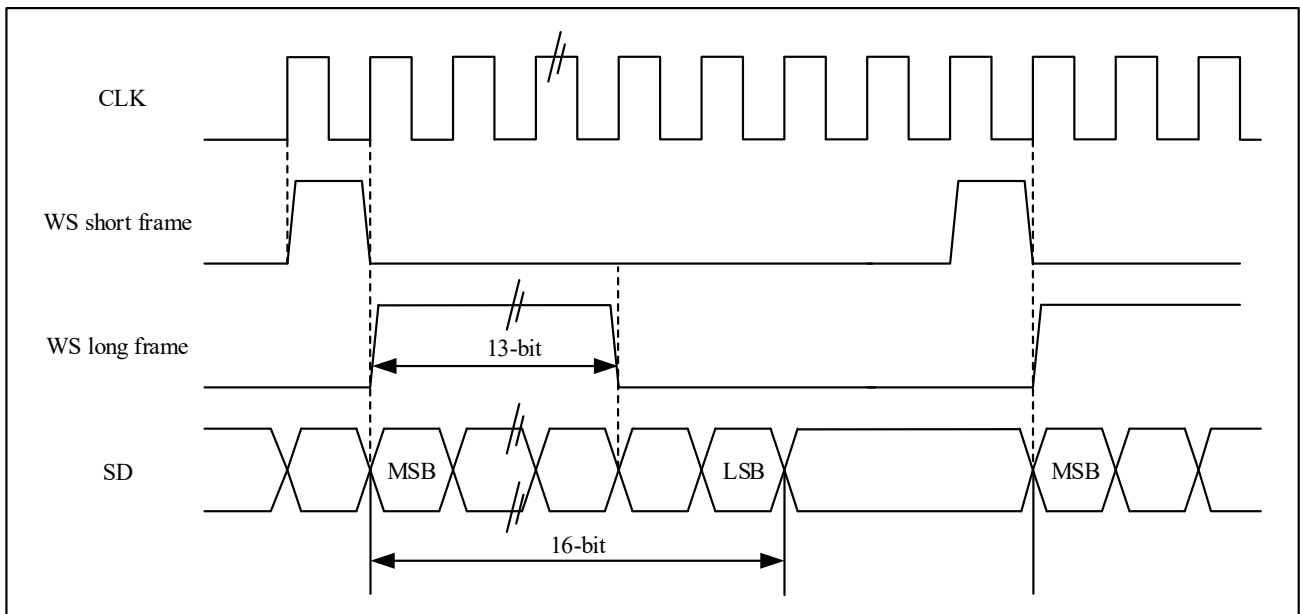
In the PCM standard, there are two frame structures, short frame and long frame. The user can select the frame structure by setting the SPI\_I2SCFG.PCMFSYNC bits. The WS signal indicates frame synchronization information. The WS signal used for synchronizing long frames is 13 bits long, while the WS signal length for synchronizing short frames is 1 bit.

The standard data receiving and transmitting processing mode is the same as I<sup>2</sup>S Philips standard.

**Figure 20-23 PCM Standard Waveform (16 Bits)**



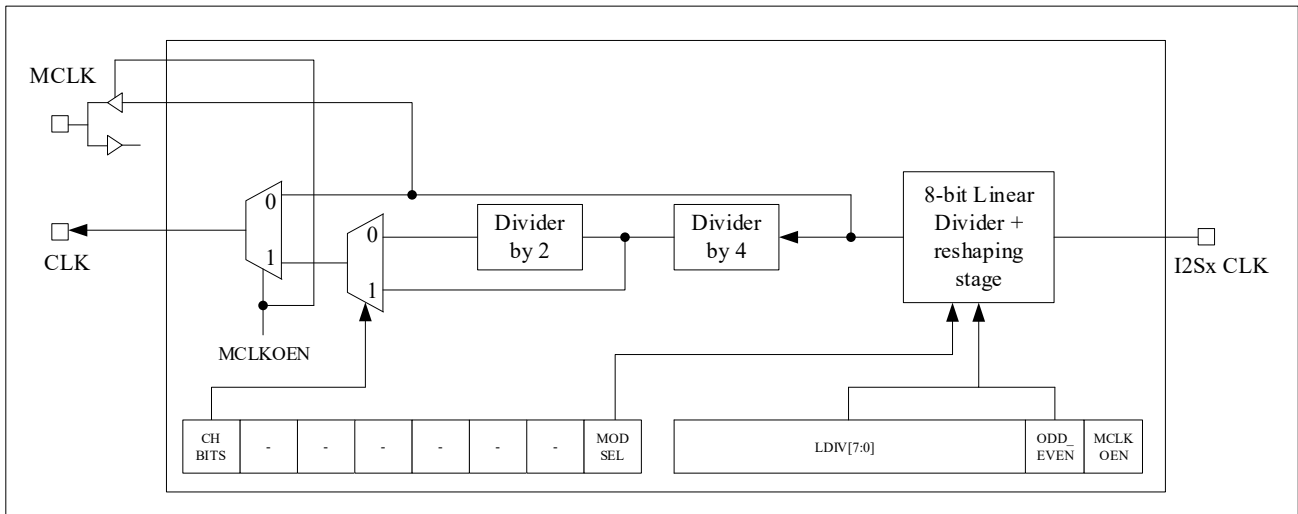
**Figure 20-24 PCM Standard Waveform (16-bit Extended to 32-bit Packet Frame)**



**20.4.2 Clock Generator**

In the master mode, the linear divider needs to be set correctly in order to obtain the desired audio frequency.

Figure 20-25 I<sup>2</sup>S Clock Generator Structure



Note: The clock source of I<sup>2</sup>Sx CLK is HSI, HSE or PLL system clock that drives AHB clock.

The bit rate of I<sup>2</sup>S determines the data flow on the I<sup>2</sup>S data line and the frequency of the I<sup>2</sup>S clock signal.

$$\text{I}^2\text{S bit rate} = \text{number of bits per channel} \times \text{number of channels} \times \text{audio sampling frequency}$$

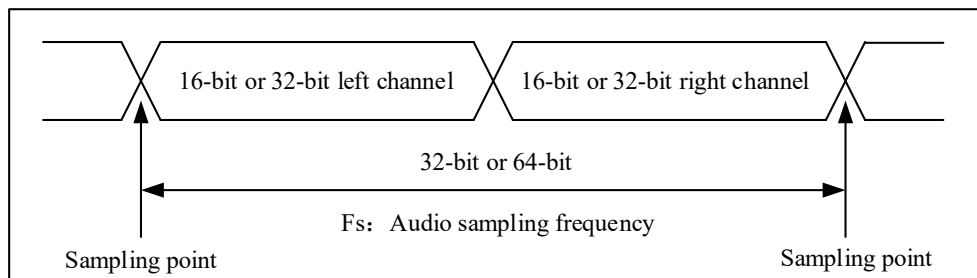
For a signal with left and right channels and 16-bit audio, the I<sup>2</sup>S bit rate is calculated as:

$$\text{I}^2\text{S bit rate} = 16 \times 2 \times F_s$$

If the packet length is 32 bits, there are:

$$\text{I}^2\text{S bit rate} = 32 \times 2 \times F_s$$

Figure 20-26 Audio Sampling Frequency Definition



The sampling signal frequency of the audio can be set by setting the SPI\_I2SPREDIV.ODD\_EVEN bit and the SPI\_I2SPREDIV.LDIV[7:0] bits. Audio can be sampled at 96kHz, 48kHz, 44.1kHz, 32kHz, 22.05kHz, 16kHz, 11.025kHz, or 8kHz (or any value within this range). Set the linear divider according to the following formula:

When MCLKOEN = 1 and CHBITS = 0,  $F_s = I^2Sx\ CLK / [(16 \times 2) \times ((2 \times LDIV) + ODD\_EVEN) \times 8]$

When MCLKOEN = 1 and CHBITS = 1,  $F_s = I^2Sx\ CLK / [(32 \times 2) \times ((2 \times LDIV) + ODD\_EVEN) \times 4]$

When MCLKOEN = 0 and CHBITS = 0,  $F_s = I^2Sx\ CLK / [(16 \times 2) \times ((2 \times LDIV) + ODD\_EVEN)]$

When MCLKOEN = 0 and CHBITS = 1,  $F_s = I^2Sx\ CLK / [(32 \times 2) \times ((2 \times LDIV) + ODD\_EVEN)]$

The exact audio frequency can be obtained by referring to the clock configuration in the table below.

**Table 20-2 Use The Standard 8MHz HSE Clock to Get Accurate Audio Frequency.**

| SYSCLK<br>(MHz) | I <sup>2</sup> S_LDIV |         | I <sup>2</sup> S_ODD_EVEN |         | MCLK    | Target<br>Fs(Hz) | Real Fs(Hz) |          | Error   |         |
|-----------------|-----------------------|---------|---------------------------|---------|---------|------------------|-------------|----------|---------|---------|
|                 | 16 Bits               | 32 Bits | 16 Bits                   | 32 Bits |         |                  | 16 Bits     | 32 Bits  | 16 Bits | 32 Bits |
| 48              | 8                     | 4       | 0                         | 0       | without | 96000            | 93750       | 93750    | 2.34%   | 2.34%   |
| 48              | 15                    | 8       | 1                         | 0       | without | 48000            | 48387.1     | 46875    | 0.81%   | 2.34%   |
| 48              | 17                    | 8       | 0                         | 1       | without | 44100            | 44117.65    | 44117.65 | 0.04%   | 0.04%   |
| 48              | 23                    | 11      | 1                         | 1       | without | 32000            | 31914.89    | 32608.7  | 0.27%   | 17.00%  |
| 48              | 34                    | 17      | 0                         | 0       | without | 22050            | 22058.82    | 22058.82 | 0.04%   | 0.04%   |
| 48              | 47                    | 23      | 0                         | 1       | without | 16000            | 15957.45    | 15957.45 | 0.27%   | 0.27%   |
| 48              | 68                    | 34      | 0                         | 0       | without | 11025            | 11029.41    | 11029.41 | 0.04%   | 0.04%   |
| 48              | 94                    | 47      | 0                         | 0       | without | 8000             | 7978.72     | 7978.72  | 0.27%   | 0.27%   |
| 48              | 1                     | 1       | 0                         | 0       | yes     | 96000            | 93750       | 93750    | 2.34%   | 2.34%   |
| 48              | 2                     | 2       | 0                         | 0       | yes     | 48000            | 46875       | 46875    | 2.34%   | 2.34%   |
| 48              | 2                     | 2       | 0                         | 0       | yes     | 44100            | 46875       | 46875    | 6.29%   | 6.29%   |
| 48              | 3                     | 3       | 0                         | 0       | yes     | 32000            | 31250       | 31250    | 2.34%   | 2.34%   |
| 48              | 4                     | 4       | 1                         | 1       | yes     | 22050            | 20833.33    | 20833.33 | 5.51%   | 5.51%   |
| 48              | 6                     | 6       | 0                         | 0       | yes     | 16000            | 15625       | 15625    | 2.34%   | 2.34%   |
| 48              | 8                     | 8       | 1                         | 1       | yes     | 11025            | 11029.41    | 11029.41 | 0.04%   | 0.04%   |
| 48              | 11                    | 11      | 1                         | 1       | yes     | 8000             | 8152.17     | 8152.17  | 1.90%   | 1.90%   |

### 20.4.3 I<sup>2</sup>S Transmit and Receive Sequence

#### 20.4.3.1 I<sup>2</sup>S initialization process

1. The user can set the SPI\_I2SPREDIV.LDIV [7:0] bits and SPI\_I2SPREDIV.ODD\_EVEN bit to configure the related prescaler and serial clock baud rate;
2. If the user needs the master device to provide the main clock MCLK to the external DAC/ADC audio device, set the SPI\_I2SPREDIV.MCLKOEN = 1. (Calculate LDIV and ODD\_EVEN according to different clock outputs, refer to section 20.4.2).
3. The user can set the SPI\_I2SCFG.CLKPOL bit to configure the polarity of the communication clock when idle; the user can set the SPI\_I2SCFG.MODSEL = 1 to configure the device to be in I<sup>2</sup>S mode, and set SPI\_I2SCFG.MODCFG[1:0] bits to select the I<sup>2</sup>S master-slave mode and transmission direction (transmit or receive); set SPI\_I2SCFG.STDSEL[1:0] bits to select the corresponding I<sup>2</sup>S standard (under the PCM standard, set the SPI\_I2SCFG.PCMFSYNC bit to select the PCM frame synchronization mode); set SPI\_I2SCFG.TDATLEN [1: 0] bits to select length of data to be transmitted, and select the number of data bits of per channel by set the SPI\_I2SCFG.CHBITS bit;
4. When user needs to enable interrupt or DMA, the configuration operation is the same as SPI;
5. Finally, set the SPI\_I2SCFG.I2SEN = 1 to start I<sup>2</sup>S communication.

#### 20.4.3.2 Master mode transmitting process

When I<sup>2</sup>S operates in master mode, the CLK pin outputs the serial clock, the WS pin generates the channel selection signal,

and set the SPI\_I2SPR.MCLKOEN bit to select whether to output the master clock (MCLK).

The transmitting process begins when data is written to the transmit buffer. When the data of the current channel is moved from the transmit buffer to the shift register in parallel, the flag bit TE (SPI\_STS.TE) is set to '1'. At this time, the data of the other channel should be written into SPI\_DAT. The channel corresponding to the current data to be transmitted is confirmed by the flag bit CHSIDE (SPI\_STS.CHSIDE). The value of CHSIDE (SPI\_STS.CHSIDE) is updated when TE (SPI\_STS.TE) is set to '1'. A complete data frame includes left and right channels, and only part of the data frame cannot be transmitted. When the flag bit TE (SPI\_STS.TE) is set to '1', if the SPI\_CTRL2.TEINTEN = 1, an interrupt will be triggered.

The operation of writing data depends on the selected I<sup>2</sup>S standard. Refer to section [20.4.1](#) for details.

When the user wants to turn off the I<sup>2</sup>S function, wait for the TE flag (SPI\_STS.TE) bit to be 1 and the BUSY flag (SPI\_STS.BUSY) bit to be 0, and then clear the SPI\_I2SCFG.I2SEN bit to 0.

### 20.4.3.3 Slave mode transmitting process

The transmitting process of the slave mode is similar to that of the master mode, the difference is as follows:

When I<sup>2</sup>S operates in slave mode, there is no need to configure the clock, and the CLK pin and WS pin are connected to the corresponding pins of the master device. The transmitting process begins when an external master transmits a clock signal, and when a WS signal requires data transfer. Only when the slave device is enabled and the data has been written to the I<sup>2</sup>S data register, the external master device can start communication.

When the first clock edge representing the next data transfer arrives, the new data has not been written into the SPI\_DAT register, an underflow occurs, and the SPI\_STS.UNDER flag bit is set to 1. If the SPI\_CTRL2.ERRINTEN bit is set to 1, an interrupt is triggered to indicate that an error has occurred.

The SPI\_STS.CHSIDE flag indicates which channel the currently transmitted data corresponds to. Compared with the master mode transmitting process, in the slave mode, SPI\_STS.CHSIDE depends on the WS signal of the external master I<sup>2</sup>S device (WS signal is 1 means the left channel).

### 20.4.3.4 Master mode receiving process

Audio is always received in 16-bit packets. According to the configured data and channel length, the received audio data will need to be transferred to the receive buffer once or twice.

When the data is transferred from the shift register to the receive buffer, the SPI\_STS.RNE flag bit is set to 1, at this time, the data is ready and can be read from the SPI\_DAT register. If the SPI\_CTRL2.RNEINTEN bit is set to 1, an interrupt will be triggered. Reading the SPI\_DAT register to clear the SPI\_STS.RNE flag. If the previously received data is not read, new data is received again, an overflow occurs, and the SPI\_STS.OVER flag is set to 1. If the SPI\_CTRL2.ERRINTEN bit is set to 1, an interrupt is triggered to indicate that an error has occurred.

The channel corresponding to the currently transmitted data can be confirmed by the SPI\_STS.CHSIDE bit. When the SPI\_STS.RNE flag bit is set to 1, the SPI\_STS.CHSIDE value is updated.

The operation of reading data depends on the selected I<sup>2</sup>S standard. Refer to section [20.4.1](#) for details.

When I<sup>2</sup>S function is turned off, different audio standards, data length and channel length adopt different operation steps:

- Data length is 16 bits, channel length is 32 bits (SPI\_I2SCFG.TDATTLEN = 00, SPI\_I2SCFG.CHBITS = 1), LSB alignment standard (SPI\_I2SCFG.STDSEL = 10).

1. Wait for the penultimate RNE flag (SPI\_STS.RNE) bit to be set to '1'.
  2. Software delay, waiting for 17 I<sup>2</sup>S clock cycles.
  3. Turn off I<sup>2</sup>S (SPI\_I2SCFG.I2SEN = 0).
- The data length is 16 bits, the channel length is 32 bits (SPI\_I2SCFG.TDATLEN = 00 and SPI\_I2SCFG.CHBITS = 1), the MSB alignment standard (SPI\_I2SCFG.STDSEL = 01), I<sup>2</sup>S Philips standard (SPI\_I2SCFG.STDSEL = 00) or PCM standard (SPI\_I2SCFG.STDSEL = 11)
    1. Wait for the last RNE flag (SPI\_STS.RNE) bit to be set to '1'.
    2. Software delay, waiting for 1 I<sup>2</sup>S clock cycle.
    3. Turn off I<sup>2</sup>S (SPI\_I2SCFG.I2SEN = 0).
  - Other combinations of SPI\_I2SCFG.TDATLEN and SPI\_I2SCFG.CHBITS and any audio mode selected by SPI\_I2SCFG.STDSEL:
    1. Wait for the penultimate RNE flag (SPI\_STS.RNE) bit to be set to '1'.
    2. Software delay, waiting for 1 I<sup>2</sup>S clock cycle.
    3. Turn off I<sup>2</sup>S (SPI\_I2SCFG.I2SEN = 0).

#### 20.4.3.5 Slave mode receiving process

The receiving process of the slave mode is similar to that of the master mode, with the following differences:

The CHSIDE flag (SPI\_STS.CHSIDE) indicates which channel corresponds to the currently transmitted data. Compared with the master mode receiving process, in the slave mode, SPI\_STS.CHSIDE depends on the WS signal of the external master device. When the I<sup>2</sup>S function is turned off, clear the SPI\_I2SCFG.I2SEN bit to 0 when the SPI\_STS.RNE flag is 1.

### 20.4.4 Status Flag

There are the following 4 flag bits in the SPI\_STS register for monitoring the status of the I<sup>2</sup>S bus.

#### 20.4.4.1 TX buffer empty flag (TE)

When the transmit buffer is empty, this flag is set to 1, indicating that new data can be written into the SPI\_DAT register. When the transmit buffer is not empty, this flag is cleared to 0.

#### 20.4.4.2 RX buffer not empty flag (RNE)

When the receive buffer is not empty, this flag is set to 1, indicating that valid data has been received into the receive buffer. When reading the SPI\_DAT register, this flag is set to 0.

#### 20.4.4.3 BUSY flag (BUSY)

When the transfer starts, the BUSY flag (SPI\_STS.BUSY) is set to 1, and when the transfer ends, the BUSY flag (SPI\_STS.BUSY) is set to 0 by hardware (software operation is invalid).

In master receiving mode (SPI\_I2SCFG.MODCFG = 11), the BUSY flag (SPI\_STS.BUSY) is set to 0 during receiving. When the I<sup>2</sup>S module is turned off or the transmission is completed, this flag is set to 0.

In the slave continuous communication mode, between each data item transmission, the BUSY flag (SPI\_STS.BUSY) goes low in 1 I<sup>2</sup>S clock cycle. Therefore, do not use the BUSY flag (SPI\_STS.BUSY) to handle the transmitting and receiving



of each data item.

#### 20.4.4.4 Channel flag (CHSIDE)

The CHSIDE (SPI\_STS.CHSIDE) bit is used to indicate the channel where the data currently transmitted and received is located. Under the PCM standard, this flag has no meaning.

In transmit mode, the flag is updated when the TE flag (SPI\_STS.TE) is set, in receive mode, the flag is updated when the RNE flag (SPI\_STS.RNE) is set. In the process of transmitting and receiving, if an overflow (SPI\_STS.OVER) or underflow (SPI\_STS.UNDER) error occurs, this flag is meaningless, and the I<sup>2</sup>S needs to be turned off and then turned on again.

### 20.4.5 Error Flag

The SPI\_STS register has 2 error flag bits.

#### 20.4.5.1 Overflow flag (OVER)

When the RNE flag (SPI\_STS.RNE) is set to 1, but there is still data received to the receive buffer, an overflow error will occur. At this time, the OVER flag (SPI\_STS.OVER) is set to 1. An interrupt will be triggered if the user enables the corresponding interrupt. All data received after this time will be lost, and the SPI\_DAT register only retains the previously unread data.

Reading the SPI\_DAT register and the SPI\_STS register in turn to clear the SPI\_STS.OVER bit.

#### 20.4.5.2 Underflow flag (UNDER)

In slave transmit mode, when the first clock edge of transmitting data arrives, if the transmit buffer is still empty, the UNDER flag (SPI\_STS.UNDER) is set to 1. An interrupt will be triggered if the user enables the corresponding interrupt.

Reading the SPI\_STS register to clears the SPI\_STS.UNDER bit.

### 20.4.6 I<sup>2</sup>S Interrupt

The following table lists all I<sup>2</sup>S interrupts.

**Table 20-3 I<sup>2</sup>S interrupt request**

| Interrupt Event               | Event Flag Bit | Enable Control Bit |
|-------------------------------|----------------|--------------------|
| Transmit buffer empty flag    | TE             | TEINTEN            |
| Receive buffer non empty flag | RNE            | RNEINTEN           |
| Underflow flag bit            | UNDER          | ERRINTEN           |
| Overflow flag bit             | OVER           |                    |

### 20.4.7 DMA Function

Operating in I<sup>2</sup>S mode, it does not need data transmission protection function, so it does not need to support CRC, other DMA functions are the same as SPI mode.

## 20.5 SPI and I<sup>2</sup>S Register Description

### 20.5.1 SPI Register Overview

Table 20-4 SPI Register Overview

| Offset | Register      | 31       | 30 | 29 | 28 | 27 | 26 | 25 | 24 | 23 | 22 | 21 | 20 | 19 | 18 | 17 | 16 | 15            | 14       | 13           | 12      | 11       | 10       | 9        | 8     | 7            | 6      | 5             | 4      | 3 | 2    | 1      | 0      |   |   |   |   |   |   |   |   |   |   |   |   |
|--------|---------------|----------|----|----|----|----|----|----|----|----|----|----|----|----|----|----|----|---------------|----------|--------------|---------|----------|----------|----------|-------|--------------|--------|---------------|--------|---|------|--------|--------|---|---|---|---|---|---|---|---|---|---|---|---|
| 000h   | SPI_CTRL1     | Reserved |    |    |    |    |    |    |    |    |    |    |    |    |    |    |    | BIDIRMODE     | BIDIROEN | CRCEN        | CRCNEXT | DATFF    | RONLY    | SSMEN    | SSEL  | LSBFF        | SPIEN  | BR[2:0]       |        |   | MSEL | CLKPOL | CLKPHA |   |   |   |   |   |   |   |   |   |   |   |   |
|        | Reset Value   | 0        |    |    |    |    |    |    |    |    |    |    |    |    |    |    |    | 0             | 0        | 0            | 0       | 0        | 0        | 0        | 0     | 0            | 0      | 0             | 0      | 0 | 0    | 0      | 0      | 0 | 0 | 0 | 0 | 0 | 0 | 0 | 0 | 0 | 0 | 0 | 0 |
| 004h   | SPI_CTRL2     | Reserved |    |    |    |    |    |    |    |    |    |    |    |    |    |    |    |               |          |              | TEINTEN | RNEINTEN | ERRINTEN | Reserved |       |              | SSOEN  | TDMAEN        | RDMAEN |   |      |        |        |   |   |   |   |   |   |   |   |   |   |   |   |
|        | Reset Value   | 0        |    |    |    |    |    |    |    |    |    |    |    |    |    |    |    |               |          |              | 0       | 0        | 0        | 0        |       |              | 0      | 0             | 0      |   |      |        |        |   |   |   |   |   |   |   |   |   |   |   |   |
| 008h   | SPI_STS       | Reserved |    |    |    |    |    |    |    |    |    |    |    |    |    |    |    |               |          |              | BUSY    | OVER     | MODERR   | CRCERR   | UNDER | CHSIDE       | TE     | RNE           |        |   |      |        |        |   |   |   |   |   |   |   |   |   |   |   |   |
|        | Reset Value   | 0        |    |    |    |    |    |    |    |    |    |    |    |    |    |    |    |               |          |              | 0       | 0        | 0        | 0        | 0     | 0            | 0      | 1             | 0      |   |      |        |        |   |   |   |   |   |   |   |   |   |   |   |   |
| 00Ch   | SPI_DAT       | Reserved |    |    |    |    |    |    |    |    |    |    |    |    |    |    |    | DAT[15:0]     |          |              |         |          |          |          |       |              |        |               |        |   |      |        |        |   |   |   |   |   |   |   |   |   |   |   |   |
|        | Reset Value   | 0        |    |    |    |    |    |    |    |    |    |    |    |    |    |    |    | 0             |          |              |         |          |          |          |       |              |        |               |        |   |      |        |        |   |   |   |   |   |   |   |   |   |   |   |   |
| 010h   | SPI_CRCPOLY   | Reserved |    |    |    |    |    |    |    |    |    |    |    |    |    |    |    | CRCPOLY[15:0] |          |              |         |          |          |          |       |              |        |               |        |   |      |        |        |   |   |   |   |   |   |   |   |   |   |   |   |
|        | Reset Value   | 0        |    |    |    |    |    |    |    |    |    |    |    |    |    |    |    | 0             |          |              |         |          |          |          |       |              |        |               |        |   |      |        |        |   |   |   |   |   |   |   |   |   |   |   |   |
| 014h   | SPI_CRCRDAT   | Reserved |    |    |    |    |    |    |    |    |    |    |    |    |    |    |    | CRCRDAT[15:0] |          |              |         |          |          |          |       |              |        |               |        |   |      |        |        |   |   |   |   |   |   |   |   |   |   |   |   |
|        | Reset Value   | 0        |    |    |    |    |    |    |    |    |    |    |    |    |    |    |    | 0             |          |              |         |          |          |          |       |              |        |               |        |   |      |        |        |   |   |   |   |   |   |   |   |   |   |   |   |
| 018h   | SPI_CRCTDAT   | Reserved |    |    |    |    |    |    |    |    |    |    |    |    |    |    |    | CRCTDAT[15:0] |          |              |         |          |          |          |       |              |        |               |        |   |      |        |        |   |   |   |   |   |   |   |   |   |   |   |   |
|        | Reset Value   | 0        |    |    |    |    |    |    |    |    |    |    |    |    |    |    |    | 0             |          |              |         |          |          |          |       |              |        |               |        |   |      |        |        |   |   |   |   |   |   |   |   |   |   |   |   |
| 01Ch   | SPI_I2SCFG    | Reserved |    |    |    |    |    |    |    |    |    |    |    |    |    |    |    | MODSEL        | I2SEN    | MODCFG [1:0] |         | PCMFSYNC | Reserved |          |       | STDSEL [1:0] | CLKPOL | TDATLEN [1:0] | CHBITS |   |      |        |        |   |   |   |   |   |   |   |   |   |   |   |   |
|        | Reset Value   | 0        |    |    |    |    |    |    |    |    |    |    |    |    |    |    |    | 0             | 0        | 0            | 0       | 0        | 0        |          |       | 0            | 0      | 0             | 0      | 0 |      |        |        |   |   |   |   |   |   |   |   |   |   |   |   |
| 020h   | SPI_I2SPREDIV | Reserved |    |    |    |    |    |    |    |    |    |    |    |    |    |    |    | MCLKOEN       | ODD_EVEN | LDIV[7:0]    |         |          |          |          |       |              |        |               |        |   |      |        |        |   |   |   |   |   |   |   |   |   |   |   |   |
|        | Reset Value   | 0        |    |    |    |    |    |    |    |    |    |    |    |    |    |    |    | 0             | 0        | 0            |         |          |          |          |       |              |        |               |        |   |      |        |        |   |   |   |   |   |   |   |   |   |   |   |   |

### 20.5.2 SPI Control Register 1 (SPI\_CTRL1) (Not Used in I<sup>2</sup>S Mode)

Address: 0x00

Reset value: 0x0000

|            |           |       |          |       |       |       |      |       |       |         |   |   |      |        |        |
|------------|-----------|-------|----------|-------|-------|-------|------|-------|-------|---------|---|---|------|--------|--------|
| 15         | 14        | 13    | 12       | 11    | 10    | 9     | 8    | 7     | 6     | 5       | 4 | 3 | 2    | 1      | 0      |
| BIDIR MODE | BIDIR OEN | CRCEN | CRC NEXT | DATFF | RONLY | SSMEN | SSEL | LSBFF | SPIEN | BR[2:0] |   |   | MSEL | CLKPOL | CLKPHA |
| rw         | rw        | rw    | rw       | rw    | rw    | rw    | rw   | rw    | rw    | rw      |   |   | rw   | rw     | rw     |

| Bit Field | Name      | Description  |
|-----------|-----------|--|
| 15        | BIDIRMODE | Bidirectional data mode enable<br>0: Select the "two-wire one-way" mode.<br>1: Select the "one-wire bidirectional " mode.<br><i>Note: Not used in I<sup>2</sup>S mode.</i> |

| Bit Field | Name     | Description  |
|-----------|----------|--|
| 14        | BIDIROEN | Output enable in bidirectional mode<br>0: Output disable (receive-only mode).<br>1: Output enabled (transmit-only mode).<br>In master mode, the "one-wire" data line is the MOSI pin, and in slave mode, the "one-wire" data line is the MISO pin.<br><i>Note: Not used in I<sup>2</sup>S mode.</i>  |
| 13        | CRCEN    | Hardware CRC check enable<br>0: Disable CRC calculation.<br>1: Enable CRC calculation.<br><i>Note: This bit can only be written when SPI is disabled (SPI_CTRL1.SPIEN = 0), otherwise an error will occur.</i><br>This bit can only be used in full duplex mode.<br><i>Note: Not used in I<sup>2</sup>S mode.</i>  |
| 12        | CRCNEXT  | Transmit CRC next<br>0: The next transmitted value comes from the transmit buffer.<br>1: The next transmitted value comes from the CRC register.<br><i>Note: This bit should be set immediately after the last data is written in SPI_DAT register.</i><br><i>Note: Not used in I<sup>2</sup>S mode.</i>   |
| 11        | DATFF    | Data frame format<br>0: 8-bit data frame format is used for transmitting/receiving.<br>1: 16-bit data frame format is used for transmitting/receiving.<br><i>Note: This bit can only be written when SPI is disabled (SPI_CTRL1.SPIEN = 0), otherwise an error will occur.</i><br><i>Note: Not used in I<sup>2</sup>S mode.</i>  |
| 10        | RONLY    | Only receive mode<br>This bit, together with the SPI_CTRL1.BIDIRMODE bit, determines the transfer direction in two-wire one-way mode. In the application scenario of multiple slave devices, this bit is only set to 1 by the accessed slave device, and only the accessed slave device can output, so as to avoid data line conflicts.<br>0: Full duplex (transmitting mode and receiving mode).<br>1: Disable output (receive-only mode).<br><i>Note: Not used in I<sup>2</sup>S mode.</i> |
| 9         | SSMEN    | Software slave device management<br>When the SPI_CTRL1.SSMEN bit is set to 1, the NSS pin level is determined by the value of the SPI_CTRL1.SSEL bit.<br>0: Disable software slave device management.<br>1: Enable software slave device management.<br><i>Note: Not used in I<sup>2</sup>S mode.</i>  |

| Bit Field | Name    | Description   |
|-----------|---------|---|
| 8         | SSEL    | <p>Internal slave device selection</p> <p>This bit only has meaning when the SPI_CTRL1.SSMEN bit is set. It determines the NSS level, and I/O operations on the NSS pin have no effect.</p> <p><i>Note: Not used in I<sup>2</sup>S mode.</i></p>  |
| 7         | LSBFF   | <p>Frame format</p> <p>0: Transmit MSB first.</p> <p>1: Transmit LSB first.</p> <p><i>Note: This bit cannot be changed during communication.</i></p> <p><i>Note: Not used in I<sup>2</sup>S mode.</i></p>   |
| 6         | SPIEN   | <p>SPI enable</p> <p>0: Disable SPI device.</p> <p>1: Enable the SPI device.</p> <p><i>Note: Not used in I<sup>2</sup>S mode.</i></p> <p><i>Note: When turning off the SPI device, please follow paragraph 0 section's procedure operation.</i></p>   |
| 5:3       | BR[2:0] | <p>Baud rate control</p> <p>000: fPCLK/2</p> <p>001: fPCLK/4</p> <p>010: fPCLK/8</p> <p>011: fPCLK/16</p> <p>100: fPCLK/32</p> <p>101: fPCLK/64</p> <p>110: fPCLK/128</p> <p>111: fPCLK/256</p> <p><i>Note: This bit cannot be changed during communication.</i></p> <p><i>Note: Not used in I<sup>2</sup>S mode.</i></p> |
| 2         | MSEL    | <p>Master device selection</p> <p>0: Configure as the slave device.</p> <p>1: Configure as the master device.</p> <p><i>Note: This bit cannot be changed during communication.</i></p> <p><i>Note: Not used in I<sup>2</sup>S mode.</i></p>   |
| 1         | CLKPOL  | <p>Clock polarity</p> <p>0: In idle state, SCLK remains low.</p> <p>1: In idle state, SCLK remains high.</p> <p><i>Note: This bit cannot be changed during communication.</i></p> <p><i>Note: Not used in I<sup>2</sup>S mode.</i></p>  |
| 0         | CLKPHA  | <p>Clock phase</p> <p>0: Data sampling starts from the first clock edge.</p> <p>1: Data sampling starts at the second clock edge.</p> <p><i>Note: This bit cannot be modified while communication is in progress.</i></p> <p><i>Note: Not used in I<sup>2</sup>S mode.</i></p>  |

### 20.5.3 SPI Control Register 2 (SPI\_CTRL2)

Address: 0x04

Reset value: 0x0000

|          |   |   |   |   |   |   |   |       |        |        |
|----------|---|---|---|---|---|---|---|-------|--------|--------|
| 15       | 8 | 7 | 6 | 5 | 4 | 3 | 2 | 1     | 0      |        |
| Reserved |   |   |   |   |   |   |   | SSOEN | TDMAEN | RDMAEN |
|          |   |   |   |   |   |   |   | rw    | rw     | rw     |

| Bit Field | Name     | Description   |
|-----------|----------|---|
| 15:8      | Reserved | Reserved,the reset value must be maintained   |
| 7         | TEINTEN  | Transmit buffer empty interrupt enable<br>0: Disable TE interrupt.<br>1: Enable TE interrupt, and interrupt request is generated when TE flag (SPI_STS.TE) is set to '1'.   |
| 6         | RNEINTEN | Receive buffer non-empty interrupt enable<br>0: Disable RNE interrupt.<br>1: Enable RNE interrupt, and generate interrupt request when RNE flag (SPI_STS.RNE) is set to '1'.  |
| 5         | ERRINTEN | Error interrupt enable<br>When an error (SPI_STS.CRCERR, SPI_STS.OVER, SPI_STS.UNDER, SPI_STS.MODERR) is generated, this bit controls whether an interrupt is generated<br>0: Disable error interrupt.<br>1: Enable error interrupt.  |
| 4:3       | Reserved | Reserved,the reset value must be maintained   |
| 2         | SSOEN    | NSS output enable<br>0: Disable NSS output in master mode, the device can operate in multi-master mode.<br>1: When the device is turned on, enable NSS output in the master mode, the device cannot operate in the multi-master device mode.<br><i>Note: Not used in I<sup>2</sup>S mode.</i> |
| 1         | TDMAEN   | Transmit buffer DMA enable<br>When this bit is set, a DMA request is issued as soon as the TE flag (SPI_STS.TE) is set<br>0: Disable transmit buffer DMA.<br>1: Enable transmit buffer DMA.   |
| 0         | RDMAEN   | Receive buffer DMA enable<br>When this bit is set, a DMA request is issued as soon as the RNE flag (SPI_STS.RNE) is set<br>0: Disable receive buffer DMA.<br>1: Enable receive buffer DMA.  |

### 20.5.4 SPI Status Register (SPI\_STS)

Address: 0x08

Reset value: 0x0002

|          |   |   |   |   |   |   |   |      |      |        |        |       |        |    |     |
|----------|---|---|---|---|---|---|---|------|------|--------|--------|-------|--------|----|-----|
| 15       | 8 | 7 | 6 | 5 | 4 | 3 | 2 | 1    | 0    |        |        |       |        |    |     |
| Reserved |   |   |   |   |   |   |   | BUSY | OVER | MODERR | CRCERR | UNDER | CHSIDE | TE | RNE |
|          |   |   |   |   |   |   |   | r    | r    | r      | rc_w0  | r     | r      | r  | r   |

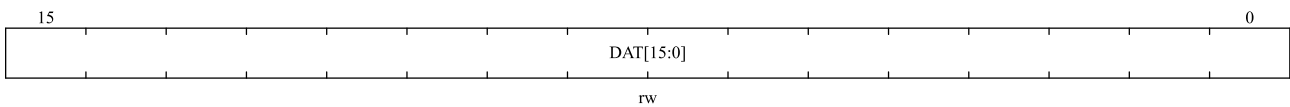
| Bit Field | Name     | Description  |
|-----------|----------|--|
| 15:8      | Reserved | Reserved, the reset value must be maintained   |
| 7         | BUSY     | Busy flag<br>0: SPI is not busy.<br>1: SPI is busy communicating or the transmit buffer is not empty.<br>This bit is set or reset by hardware.<br><i>Note: Use of this flag requires special attention, see section 20.3.3 and section 20.4.4.3 for details..</i>  |
| 6         | OVER     | Overflow flag<br>0: No overflow error.<br>1: An overflow error occurred.<br><i>Note: This bit is set by hardware and cleared according to the sequence of software operations. For more information about software sequences, refer to 20.3.7.2 for details.</i>   |
| 5         | MODERR   | Mode error<br>0: No mode error.<br>1: A mode error occurred.<br><i>Note: This bit is set by hardware and cleared according to the sequence of software operations. For more information about software sequences, refer to 20.3.7 for details.</i><br><i>Note: Not used in I<sup>2</sup>S mode.</i>          |
| 4         | CRCERR   | CRC error flag<br>0: The received CRC value matches the value the SPI_CRCRDAT register value.<br>1: The received CRC value does not match the SPI_CRCRDAT register value.<br><i>Note: this bit is set by hardware and cleared by software by writing 0.</i><br><i>Note: Not used in I<sup>2</sup>S mode.</i> |
| 3         | UNDER    | Underflow flag<br>0: No underflow occurred.<br>1: Underflow occurred.<br><i>Note: This bit is set by hardware and cleared according to the sequence of software operations. For more information about software sequences, refer to 0 for details.</i><br><i>Note: not used in SPI mode.</i>                 |
| 2         | CHSIDE   | Channel<br>0: The left channel needs to be sent or received;<br>1: The right channel needs to be sent or received.<br><i>Note: not used in SPI mode. No meaning in PCM mode.</i>   |
| 1         | TE       | The transmit buffer is empty<br>0: The transmit buffer is not empty.   |

| Bit Field | Name | Description   |
|-----------|------|---|
|           |      | 1: The transmit buffer is empty.  |
| 0         | RNE  | Receive buffer is not empty<br>0: The receive buffer is empty.<br>1: The receive buffer is not empty. |

### 20.5.5 SPI Data Register (SPI\_DAT)

Address: 0x0C

Reset value: 0x0000

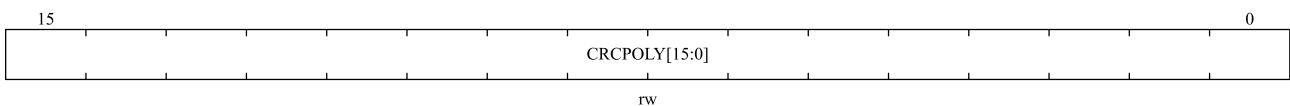


| Bit Field | Name      | Description  |
|-----------|-----------|--|
| 15:0      | DAT[15:0] | Data register<br>Data to be sent or received<br>The data register corresponds to two buffers: one for write (transmit buffer); The other is for read (receive buffer). Write operation writes data to transmit buffer; The read operation will return the data in the receive buffer.<br>Note on SPI mode: According to the selection of the data frame format by the SPI_CTRL1.DATFF bit, the data transmitting and receiving can be 8-bit or 16-bit. To ensure correct operation, the data frame format needs to be determined before enabling the SPI.<br>For 8-bit data, the buffer is 8-bit, and only SPI_DAT[7:0] is used when transmitting and receiving. When receiving, SPI_DAT[15:8] is forced to 0.<br>For 16-bit data, the buffer is 16-bit, and the entire data register is used when transmitting and receiving, that is, SPI_DAT[15:0]. |

### 20.5.6 SPI CRC Polynomial Register (SPI\_CRCPOLY) (Not Used in I<sup>2</sup>S Mode)

Address: 0x10

Reset value: 0x0007

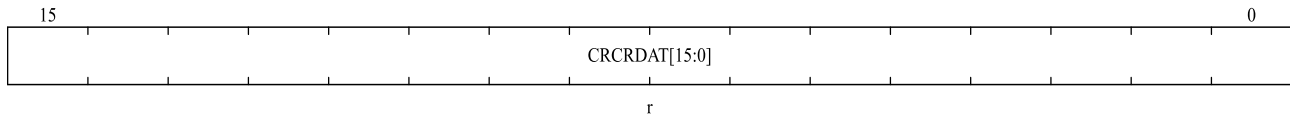


| Bit Field | Name           | Description   |
|-----------|----------------|---|
| 15:0      | CRCPOLY [15:0] | CRC polynomial register<br>This register contains the polynomial used for the CRC calculation.<br>The reset value is 0x0007, other values can be set according to the application.<br><i>Note: not used in I<sup>2</sup>s mode.</i> |

### 20.5.7 SPI RX CRC Register (SPI\_CRCDAT) (Not Used in I<sup>2</sup>S Mode)

Address offset: 0x14

Reset value: 0x0000

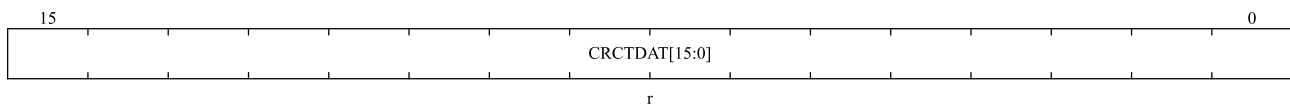


| Bit Field | name   | description  |
|-----------|--------|--|
| 15:0      | CRCDAT | <p>Receive CRC register</p> <p>When CRC calculation is enabled, CRCDAT[15:0] will contain the calculated CRC value of subsequent received bytes. This register is reset when '1' is written to the SPI_CTRL1.CRCEN bit. The CRC calculation uses the polynomial in SPI_CRCPOLY.</p> <p>When the data frame format is set to 8 bits, only the lower 8 bits participate in the calculation and follow the CRC8 standard; when the data frame format is 16 bits, all 16 bits in the register participate in the calculation and follow the CRC16 standard.</p> <p><i>Note: reading this register when the BUSY flag (SPI_STS.BUSY) is '1' may read incorrect values.</i></p> <p><i>Note: not used in I<sup>2</sup>S mode.</i></p> |

### 20.5.8 SPI TX CRC Register (SPI\_CRCTDAT)

Address offset: 0x18

Reset value: 0x0000



| Bit Field | Name    | Description  |
|-----------|---------|--|
| 15:0      | CRCTDAT | <p>Send CRC register</p> <p>When CRC calculation is enabled, CRCTDAT[15:0] contains the CRC value calculated by the bytes sent subsequently. This register is reset when '1' is written to the SPI_CTRL1.CRCEN bit. The CRC calculation uses the polynomial in SPI_CRCPOLY.</p> <p>When the data frame format is set to 8 bits, only the lower 8 bits participate in the calculation and follow the CRC8 standard; when the data frame format is 16 bits, all 16 bits in the register participate in the calculation and follow the CRC16 standard.</p> <p><i>Note: reading this register when the BUSY flag (SPI_STS.BUSY) is '1' may read incorrect values.</i></p> <p><i>Note: not used in I<sup>2</sup>S mode.</i></p> |

### 20.5.9 SPI\_I<sup>2</sup>S Configuration Register (SPI\_I2SCFG)

Address offset: 0x1c

Reset value: 0x0000



|          |    |        |       |             |   |              |          |             |    |        |              |   |        |
|----------|----|--------|-------|-------------|---|--------------|----------|-------------|----|--------|--------------|---|--------|
| 15       | 12 | 11     | 10    | 9           | 8 | 7            | 6        | 5           | 4  | 3      | 2            | 1 | 0      |
| Reserved |    | MODSEL | I2SEN | MODCFG[1:0] |   | PCM<br>FSYNC | Reserved | STDSEL[1:0] |    | CLKPOL | TDATLEN[1:0] |   | CHBITS |
|          |    | rw     | rw    |             |   | rw           |          |             | rw | rw     |              |   | rw     |

| Bit Field | Name     | Description   |
|-----------|----------|---|
| 15:12     | Reserved | Reserved, the reset value must be maintained  |
| 11        | MODSEL   | I <sup>2</sup> S mode selection<br>0: Select SPI mode.<br>1: Select I <sup>2</sup> S mode.<br><i>Note: this bit can only be set when SPI or I<sup>2</sup>S is turned off.</i>   |
| 10        | I2SEN    | I <sup>2</sup> S enable<br>0: Disable I <sup>2</sup> S.<br>1: Enable I <sup>2</sup> S.<br><i>Note: not used in SPI mode.</i>  |
| 9:8       | MODCFG   | I <sup>2</sup> S mode setting<br>00: Slave device transmits.<br>01: Slave device receives.<br>10: Master device transmits.<br>11: Master device receives.<br><i>Note: This bit can only be set when I<sup>2</sup>S is turned off.</i><br><i>Note: not used in SPI mode.</i>   |
| 7         | PCMFSYNC | PCM frame synchronization<br>0: Short frame synchronization.<br>1: Long frame synchronization.<br><i>Note: This bit is only meaningful when SPI_I2SCFG.STDSEL = 11 (used by the PCM standard).</i><br><i>Note: not used in SPI mode.</i>  |
| 6         | Reserved | Reserved, the reset value must be maintained  |
| 5:4       | STDSEL   | Selection of I <sup>2</sup> S standard<br>00: I <sup>2</sup> S Philips standard.<br>01: High byte alignment standard (left alignment).<br>10: Low byte alignment standard (right alignment).<br>11: PCM standard.<br>See for details of I <sup>2</sup> S standard on section 20.4.1.<br><i>Note: For correct operation, this bit can only be set when I<sup>2</sup>S is turned off.</i><br><i>Note: not used in SPI mode.</i> |
| 3         | CLKPOL   | Static clock polarity<br>0: I2S clock static state is low level.<br>1: I2S clock static state is high level.<br><i>Note: For correct operation, this bit can only be set when I<sup>2</sup>S is turned off.</i><br><i>Note: not used in SPI mode.</i>   |



## 21 Real-time Clock (RTC)

### 21.1 Description

- The real-time clock (RTC) is an independent BCD timer/counter.
- Daylight saving time compensation supported by software.
- A periodic automatic programmable wakeup timer.
- Two programmable alarms.
- Two 32-bit registers contain the seconds, minutes, hours, days (day of week), days (day of month), months, and years.
- Two 32-bit registers contain two programmable alarms sub-seconds.
- Digital calibration function.
- Reference clock detection: a more precise external source clock (50 or 60 Hz) can be used to improve the calendar precision.
- 2 tamper detection events with configurable filter and internal pull-up.
- Time-stamp function.
- Multiple wakeup sources of interrupt/event. These include Alarm A, Alarm B, wakeup timer, time-stamp, tamper.
- Automatically perform month compensation for 28, 29 (leap year), 30, and 31 days.
- After RTC is enabled by the RCC register and voltage remains in the operating range, RTC will not stop timing in RUN mode, LPRUN mode, SLEEP mode and STOP mode.
- RTC provides a variety of ways to wakeup from SLEEP mode and STOP mode.

### 21.2 Main features

**Table 21-1 RTC Feature Support**

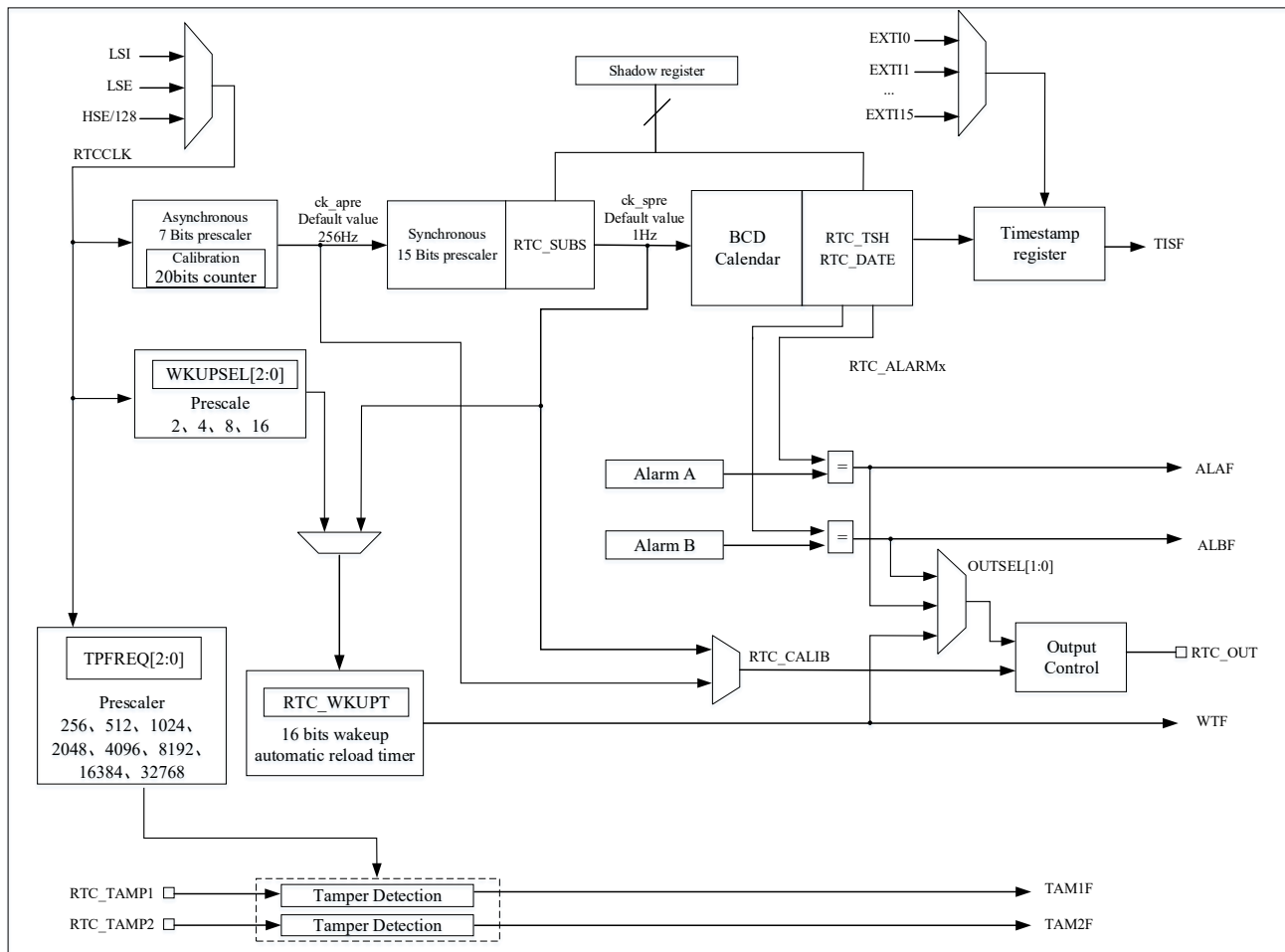
| Main Function | Description  |
|---------------|--|
| Clock         | RTC clock can be selected from LSI, LSE and HSE, which are 30KHz, 32.768KHz and HSE / 128 respectively   |
| Calendar      | Calendar consists of sub second, second, minute, hour (12 or 24 format), day (day of the week), date, month and year. These data are stored in the shadow register of APB module.  |
| Wakeup Timer  | Output “RTC_OUT” can be configured to send wakeup events to GPIO. At the same time, it also can be configured as an interrupt/event to wake up the system from SLEEP, STOP modes.  |
| Alarm         | Programmable alarm clock and interrupt function. The alarm can be triggered by any combination of the calendar fields. When the alarm event occurs the alarm flag can be sent to GPIO through “RTC_OUT”, and it also can be used to wake up the CPU or exit from the low power status such as SLEEP, STOP modes. |

| Main Function     | Description   |
|-------------------|---|
| Tamper            | 2 Tamper detection logic are a source of system Wakeup should a Tamper event happen on one of the input lines. It is also a source of hardware trigger to LP Timer.     |
| Timestamp         | Time-stamp function for GPIO event saving. It is a source to Wakeup system from low power modes.<br>Alternatively a tamper event could be a source of Time-stamp event. |
| Interrupts/Events | Alarm A/Alarm B interrupt<br>Wakeup interrupt<br>Timestamp interrupt<br>Tamper interrupt  |

## 21.3 RTC Function Description

### 21.3.1 RTC Block Diagram

Figure 21-1 RTC Block Diagram



RTC includes the following functions:

- Alarm A and Alarm B event/interrupt

- Timestamp event/interrupt
- Tamper event/interrupt
- RTC output functions
  - 256 Hz or 1Hz clock output (LSE frequency is 32.768 kHz).
  - Alarm clock output (polarity configurable), Alarm A and Alarm B are optional.
  - Auto wakeup output (polarity configurable).
- RTC input functions:
  - Timestamp event detection
  - 50 or 60Hz reference clock input
  - Tamper event detection

### 21.3.2 GPIOs of RTC

Timestamp input come from IOM (mapped to PC13) or EXTI module, if EXIT module is needed to start, please refer to the timestamp trigger source selection register (EXTI\_TS\_SEL) for details.

RTC\_OUT (Alarm, wakeup event or calibration output (256Hz or 1Hz)) is mapped to PC13. Regardless of the PC13 GPIO configuration, the PC13 pin configuration is controlled by the RTC as an output.

PC13 can be used as RTC TAMPER1 tamper detection pin, PA0 can be used as RTC TAMPER2 tamper detection pin, the both pins are controlled by the RTC as a pull-up input.

PA10 or PB15 can be used as RTC\_REFCLKIN reference clock input pin.

### 21.3.3 RTC Register Write Protection

After power-up or reset, all RTC registers except RTC\_CTRL, RTC\_TMPCFG, RTC\_INITSTS[13:8] are write-protected. All write protection RTC registers require the following steps to unlock write protection:

- Write “0xCA” into RTC\_WRP register.
- Write “0x53” into RTC\_WRP register.

After unlocking these registers, they cannot have write protection unless the RTC is soft reset or power cycled. The unlocking mechanism only checks the write operation to the RTC\_WRP register. During the unlocking process, before unlocking, and after unlocking, write operations to other registers will not affect the unlocking result.

### 21.3.4 RTC Clock and Prescaler

RTC clock source:

- LSE clock
- LSI clock
- HSE/128 clock

In order to reduce power consumption, the prescaler is divided into 2 programmable prescalers, they are asynchronous prescaler and synchronous prescaler. If both prescaler are used, it is recommended that the value of the asynchronous

divider be as large as possible.

- A 7-bit asynchronous prescaler which is configured by RTC\_PRE.DIVA[6:0] bits
- A 15-bit synchronous prescaler which is configured by RTC\_PRE.DIVS[14:0] bits

The formula for  $f_{ck\_apre}$  and  $f_{ck\_spre}$  are given below:

$$f_{ck\_apre} = \frac{f_{RTCCLK}}{RTC\_PRE.DIVA[6:0]+1}$$

$$f_{ck\_spre} = \frac{f_{RTCCLK}}{(RTC\_PRE.DIVS[14:0]+1)*(RTC\_PRE.DIVA[6:0]+1)}$$

The ck\_apre clock is used to driven RTC\_SUBS sub-second down counter. When RTC\_SUBS reaches 0, reload RTC\_SUBS with the value of RTC\_PRE.DIVS[14:0].

### 21.3.5 RTC Calendar

There are three shadow registers, they are RTC\_DATE, RTC\_TSH and RTC\_SUBS. The RTC time and date registers can be accessed through the shadow registers. It is also possible to access them directly to avoid the synchronization waiting time. The three shadow registers are as follow:

- RTC\_DATE: set and read date
- RTC\_TSH: set and read time
- RTC\_SUBS: read sub-second

After every two RTCCLK cycles, the current calendar value is copied to the shadow register, and RTC\_INITSTS.RSYF bit is set to 1. This process is not performed in low power modes. While exiting these modes, the shadow register updates the values after 2 RTCCLK cycles.

By default, when users try to access the calendar register, they are actually accessing the contents of the shadow register. User can access the calendar register directly by setting the RTC\_CTRL.BYPS bit.

When RTC\_CTRL.BYPS=0, calendar values are from shadow registers, when reading RTC\_SUBS, RTC\_TSH or RTC\_DATE register, it is necessary to make ensure the frequency of APB1 clock ( $f_{APB1}$ ) is at least 7 times the frequency of RTC clock ( $f_{RTCCLK}$ ), and APB1 clock frequency lower than RTC clock frequency is not allowed in any case. System reset will reset shadow registers.

*Note: If the sub-second matching interrupt is configured, the first sub-second matching interrupt may not be triggered, and the subsequent sub-second matching interrupts are normal, and the first sub-second matching interrupt can be ignored.*

### 21.3.6 Calendar Initialization and Configuration

The value of prescaler and calendar can be initialized by the following steps:

- Enter initialization mode by setting “1” to RTC\_INITSTS.INITM bit, then wait for RTC\_INITSTS.INITF flag to be set 1.
- Set RTC\_PRE.DIVS[14:0] and RTC\_PRE.DIVA[6:0] value.
- Write the initial calendar values including time and date into the shadow registers (RTC\_TSH and RTC\_DATE) and configure the time format (12 or 24 hours) by the RTC\_CTRL.HFMT bit.

- Exit initialization mode by clearing the RTC\_INITSTS.INITM bit.

The values of calendar counter will automatically loaded from shadow registers after 4 RTCCLK clock cycles, then the calendar counter restarts.

*Note: Before entering the RTC initialization mode, please ensure that the value of RTC\_SUBS.SS[15:0] is not less than 2, and read RTC\_DATE register once.*

### 21.3.7 Calendar Reading

#### 1. Reading calendar value when RTC\_CTRL.BYPS=0

Calendar value is read from shadow registers if RTC\_CTRL.BYPS=0. In order to read RTC calendar registers (RTC\_SUBS, RTC\_TSH and RTC\_DATE) correctly, APB1 clock frequency must be set equal to or greater than 7 times of RTC clock frequency. In any case, APB1 clock frequency must not be less than RTC clock frequency.

If APB1 clock frequency is not equal to or greater than 7 times of RTC clock frequency, refer to the following process to read calendar value.

- Read the data of RTC\_SUBS, RTC\_TSH and RTC\_DATE twice.
- Compare the data read twice, if they are equal, the read data can be considered correct; if they are not equal, read the data for the third time.
- The third time read data can be considered correct.

Shadow registers (RTC\_SUBS, RTC\_TSH and RTC\_DATE) are updated every two RTCCLK cycles. If user want to read calendar value in a short time(less than two RTCCLK cycles), RTC\_INITSTS.RSYF bit must be cleared by software after the first time read.

In some cases, it is necessary to wait until RTC\_INITSTS.RSYF bit is set 1 before read calendar value.

- After waking up from the low power mode (STOP mode), clear RTC\_INITSTS.RSYF bit, then wait RTC\_INITSTS.RSYF bit is set again.
- System reset.
- Calendar complete initialization.
- Calendar complete synchronization.

#### 2. Reading calendar value when RTC\_CTRL.BYPS=1

Reading the calendar value directly from the calendar counter if RTC\_CTRL.BYPS=1. The advantage of this configuration is that there is no delay in reading the calendar values after waking up from lowpower mode, the disadvantage is that these data of RTC\_SUBS, RTC\_TSH and RTC\_DATE may not be at a time.

To ensure the correctness of read calendar value, it is necessary to read RTC\_SUBS, RTC\_TSH and RTC\_DATE twice, then compare the data read twice, if they are equal, the read data can be considered correct.

*Note: After read RTC\_TSH or RTC\_SUBS register, it needs to read RTC\_DATE register once.*

### 21.3.8 Calibration Clock Output

If RTC\_CTRL.COEN is set to 1, PC13 pin will output calibration clock. If RTC\_CTRL.CALOSEL=0 and

RTC\_PRE.DIVA[6:0] = 0x7F, the RTC\_CALIB frequency results is  $f_{RTCCLK}/RTC\_PRE.DIVA[6:0]$ . The calibration output is 256Hz when the RTCCLK frequency is 32.768 kHz. The rising edge is recommended for there is slight jitter on the falling edge.

When RTC\_CTRL.CALOSEL=1 and "RTC\_PRE.DIVS[14:0]+1" is a non-zero integer multiple of 256, the RTC\_CALIB frequency is  $f_{RTCCLK}/(256 * (DIVA+1))$ . The calibration output is 1Hz when the RTCCLK frequency is 32.768 kHz and RTC\_PRE.DIVA[6:0] = 0x7F.

*Note: When the RTC\_CALIB or RTC\_ALARM output is selected, the RTC\_OUT pin (PC13) is automatically configured as output.*

### 21.3.9 Programmable Alarms

RTC has 2 programmable alarms: Alarm A and Alarm B.

RTC alarm can be enabled or disable by RTC\_CTRL.ALxEN bit. If all the alarm value match the calendar values, the RTC\_INITSTS.ALxF flag will be set. Each calendar field can be selected to trigger alarm interrupt if RTC\_CTRL.ALxIEN bit is enabled.

Alarm output: Alarm A and Alarm B can be mapped to RTC\_ALxRM output when RTC\_CTRL.OUTSEL[1:0] is selected, and output polarity can be configured by RTC\_CTRL.OPOL bit.

*Note: If the second field is selected (RTC\_ALARMx.MASK1 bit reset), RTC\_PRE.DIVS[14:0] must be larger than 3 to ensure correct operation.*

### 21.3.10 Alarm Configuration

Alarm A and Alarm B should be configured in the following below:

- Disable Alarm A/Alarm B by clearing RTC\_CTRL.ALAEN/RTC\_CTRL.ALBEN bit.
- Configure the Alarm x registers (RTC\_ALRMxSS/RTC\_ALARMx)
- Enable Alarm A/Alarm B interrupt by set RTC\_CTRL.ALAIEN/RTC\_CTRL.ALBIEEN bit (this step can be selected as needed )
- Enable Alarm A/Alarm B by setting RTC\_CTRL.ALAEN/ RTC\_CTRL.ALBEN bit.

### 21.3.11 Alarm Output

When RTC\_CTRL.OUTSEL[1:0] !=0, RTC\_ALARM alternate function output is enable. Select the Alarm A output, Alarm B output or wakeup output based on the value of RTC\_CTRL.OUTSEL[1:0] bits.

RTC\_CTRL.OPOL bit controls the polarity of the Alarm A, Alarm B or wakeup output.

When RTC\_CALIB or RTC\_ALARM output is selected, the RTC\_OUT pin (PC13) is automatically configured as output.

### 21.3.12 Periodic Automatic Wakeup

A 16-bit programmable auto-load down counter can generate periodic wakeup flag when reach 0. It is also can be extend the range of wakeup timer to 17 bits. Periodic automatic wakeup can be enabled by setting RTC\_CTRL.WTEN.

There are two wake-up input clock sources can be selected:

- RTC clock (RTCCLK) divided by 2/ 4/8/16.



Assume RTCCLK comes from LSE (32.768KHz), wake-up interrupt period can be configured range from 122us to 32s under the resolution is 61us.

- Internal clock ck\_spre.

Assume ck\_spre frequency is 1Hz, the available wake-up time range from 2s to 36h, and the resolution is 1 second.

- When RTC\_CTRL.WKUPSEL [2:0] = 10x, the period is range from 2s to 18h.
- When RTC\_CTRL.WKUPSEL [2:0] = 11x, the period is range from 18h to 36h.

After RTC\_CTRL.WTEN bit is set to 1, the down counter is running and when it reaches 0, RTC\_INITSTS.WTF will be set and the device can exit from low power mode when the periodic wakeup interrupt is enabled by setting the RTC\_CTRL.WTIEN bit.

Periodic wakeup output: periodic wakeup can be mapped to RTC\_ALxRM output when RTC\_CTRL.OUTSEL[1:0] is selected, the RTC\_OUT pin(PC13) is automatically configured as output, and output polarity can be configured by RTC\_CTRL.OPOL bit.

### 21.3.13 Wakeup Timer Configuration

The wakeup timer automatic reload value should be configured in the following below:

- Disable wakeup timer by clearing RTC\_CTRL.WTEN bit, then wait for RTC\_INITSTS.WTWF flag to be set 1.
- Select wake up timer clock by set RTC\_CTRL.WKUPSEL[2:0] bits.
- Configure the wake-up automatic reload value by set RTC\_WKUPT.WKUPT[15:0] bits.
- Enable Wakeup interrupt by set RTC\_CTRL.WTIEN bit(this step can be selected as needed )
- Enable wakeup timer by setting RTC\_CTRL.WTEN bit

### 21.3.14 Timestamp Function

Timestamp can be enabled by setting RTC\_CTRL.TSEN bit to 1. When a timestamp event is detected on the RTC\_TS pin, the calendar values of the event will be stored in the timestamp register (RTC\_TSSS, RTC\_TST, RTC\_TSD), and RTC\_INITSTS.TISF is set to 1. Timestamp event can trigger an interrupt if RTC\_CTRL.TSIEN is set to 1. If a new timestamp event is detected when RTC\_INITSTS.TISF has been set to 1 already, the hardware sets RTC\_INITSTS.TISOVF flag to 1, and the timestamp registers (RTC\_TST and RTC\_TSD) will continue to hold the value of the previous event, which means timestamp registers(RTC\_TST and RTC\_TSD) data will not change when RTC\_INITSTS.TISF=1.

After the timestamp event caused by the synchronization process occurs again, RTC\_INITSTS.TISF is set to 1 in 2 RTC\_CLK cycles. There is no delay in the generation of RTC\_INITSTS.TISOVF. This means that if two timestamp events are very close, this can cause RTC\_INITSTS.TISOVF to be "1" and RTC\_INITSTS.TISF to be "0". Therefore, after detecting that RTC\_INITSTS.TISF is "1", then detect RTC\_INITSTS.TISOVF bit.

Tamper event can trigger timestamp event when RTC\_TMPCFG.TPTS bit is set to 1.

If timestamp events are enabled, the timestamp will capture the calendar read in the timestamp register. When both tamper events and timestamp events are enabled, tamper events can also result in timestamp capture. Timestamp events can be generated on any of the 16 GPIO ports selected by EXTI. The GPIO pins in each port are selected by setting the

corresponding EXTI\_TS\_SEL.TSSEL[3:0] bits.

### 21.3.15 Tamper Detection

There are 2 tamper detection pins, RTC\_TAMP1 pin is PC13, RTC\_TAMP2 pin is PA0. RTC\_TAMPx pin can be used as tamper event detection function input pin. There are two detection modes, edge detection mode and level detection mode with configurable filtering function.

#### Tamper detection initialization

There are 3 tamper detection pins, each of them can be configured independently. User need to configure tamper detection before enable RTC\_TMPCFG.TPxEN bit. When the tamper event is detected after tamper detection is enable, if RTC\_TMPCFG.TPxINTEN is set to 1, tamper event can trigger an interrupt and RTC\_INITSTS.TAMxF bit will be set 1.

When RTC\_INITSTS.TAMxF is set to 1, a new tamper event on the same pin cannot be detected.

#### Timestamp on tamper event

Any tamper event can cause a timestamp event when RTC\_INITSTS.TPTS is set to 1, and RTC\_INITSTS.TISF bit and RTC\_INITSTS.TISOVF bit will be set as a normal timestamp event.

#### Edge detection of tamper input

When RTC\_TMPCFG.TPFLT[1:0] bits are set to 0, tamper detection is set to edge detection, and the selection of rising edge or falling edge is controlled by RTC\_TMPCFG.TPxTRG bit. The RTC\_TAMPx pin will generate a tamper detection event when corresponding edge is detected.

When edge detection is used, in order to ensure that a valid edge occurs after the tamper event detection is enabled, it is recommended to check the tamper detection pin level by software immediately after enabling it; when  $RTC\_TMPCFG.TPFLT[1:0] = 0$  and  $RTC\_TMPCFG.TPxTRG = 0$ , if the tamper detection is enabled and the tamper input is high before detection, the tamper event can be detected by hardware.

#### Filtered level detection of RTC\_TAMPx input

When RTC\_TMPCFG.TPFLT[1:0] bits are set to 1/2/3, tamper detection is set to level detection. The value of RTC\_TMPCFG.TPFLT[1:0] determines the number of samples.

Before each sampling, precharging can be done through the internal pull-up resistor of the tamper pin, and the pre-charging time is controlled by the RTC\_TMPCFG.TPPRCH[1:0] bits. Precharge will be disabled when RTC\_TMPCFG.TPPUDIS set 1.

Using RTC\_TMPCFG.TPFREQ[2:0] to determine the sampling frequency of level detection can optimize the best balance between tamper detection delay and pull-up power consumption.

### 21.3.16 Daylight Saving Time Function Configuration

Daylight saving time function can be controlled by RTC\_CTRL.SU1H, RTC\_CTRL.AD1H, and RTC\_CTRL.BAKP bits. Calendar will subtract one hour when set RTC\_CTRL.SU1H bit to 1, and add one hour when set RTC\_CTRL.AD1H to 1. RTC\_CTRL.BAKP can be used to record whether this operation was performed.

### 21.3.17 RTC Sub-second Register Shift

When the value of calendar has a sub-second deviation compared to the external precision clock, the shift function can be

used to improve the precision of calendar.

Calendar can use RTC\_SCTRL.AD1S and RTC\_SCTRL.SUBF[14:0] bits to control maximum delay or advance 1s. The resolution of the adjustment is  $1/(RTC\_PRE.DIVS[14:0]+1)$  second, it means the higher value of RTC\_PRE.DIVS[14:0], the higher of the resolution. However, to keep the synchronous prescaler output at 1Hz, the higher RTC\_PRE.DIVS[14:0] means the lower RTC\_PRE.DIVA[6:0], then more power consuming.

*Note: Before starting a shift operation, user must check if the RTC\_SUBS.SS[15] bit is 0.*

Whenever RTC\_SCTRL register is written, the RTC\_INITSTS.SHOPF flag will be set by hardware, which indicate a shift operation is pending. Once this shift operation is complete, the bit is cleared by hardware.

### 21.3.18 RTC Digital Clock Precision Calibration

Digital precision calibration is achieved by adjusting the number of RTC clock pulses in the calibration period. Digital precision calibration resolution is 0.954 PPM with the range from -487.1 PPM to +488.5 PPM.

When the input frequency is 32768 Hz, calibration period can be configured as  $2^{20}/2^{19}/2^{18}$  RTCCLK cycles or 32/16/8 seconds. The precision calibration register (RTC\_CALIB) indicates that there has RTC\_CALIB.CM[8:0] RTCCLK clock cycles will be reduced during the specified period.

The value of RTC\_CALIB.CM[8:0] represents the number of RTCCLK pulses to be reduced during specified period. While RTC\_CALIB.CP can be used to increase 488.5 PPM, every  $2^{11}$  RTCCLK cycles will inserts a RTCCLK pulse.

When RTC\_CALIB.CM[8:0] and RTC\_CALIB.CP are used together, it can increase cycles range from -511 to +512 RTCCLK cycles, and the calibration range from -487.1 ppm to +488.5 ppm, with the resolution is about 0.954 ppm.

The effective calibrated frequency ( $f_{CAL}$ ) can be calculated by using the formula given below:

$$f_{CAL} = f_{RTCCLK} * \left( 1 + \frac{RTC\_CALIB.CP * 512 - RTC\_CALIB.CM[8:0]}{2^n + RTC\_CALIB.CM[8:0] - RTC\_CALIB.CP * 512} \right)$$

*Note: n=20/19/18*

#### Calibrate when RTC\_PRE.DIVA[6:0]<3

When the asynchronous prescaler value (RTC\_PRE.DIVA[6:0]) is less than 3, the RTC\_CALIB.CP cannot be programmed to 1, and RTC\_CALIB.CP value will be ignored if it has been set to 1.

Assume RTCCLK frequency is 32768Hz, when RTC\_PRE.DIVA[6:0]<3, the value of RTC\_PRE.DIVS[14:0] should be decrease:

- When RTC\_PRE.DIVA[6:0] = 2, RTC\_PRE.DIVS[14:0] = 8189.
- When RTC\_PRE.DIVA[6:0] = 1, RTC\_PRE.DIVS[14:0] = 16379.
- When RTC\_PRE.DIVA[6:0] = 0, RTC\_PRE.DIVS[14:0] = 32759.

The effective calibrated frequency ( $f_{CAL}$ ) can be calculated by using the formula given below:

$$f_{CAL} = f_{RTCCLK} * \left( 1 + \frac{256 - RTC\_CALIB.CM[8:0]}{2^n + RTC\_CALIB.CM[8:0] - 265} \right)$$

*Note: n=20/19/18*

### Verify RTC calibration

RTC output 1Hz waveform for measuring and verifying RTC precision.

Up to 2 RTCCLK cycles measurement error may occur when measure the RTC frequency in a limit measurement period. If the measurement period is the same as calibration period, the error can be eliminated.

- The calibration period is 32 seconds (default).

Using an accurate 32-second period to measure the 1Hz calibration output can ensure that the measurement error is within 0.447ppm (0.5 RTCCLK cycles within 32 seconds).

- The calibration period is 16 seconds.

Using an accurate 16-second period to measure the 1Hz calibration output can ensure that the measurement error is within 0.954ppm (0.5 RTCCLK cycles within 16 seconds).

- The calibration period is 8 seconds.

Using an accurate 8-second period to measure the 1Hz calibration output can ensure that the measurement error is within 1.907ppm (0.5 RTCCLK cycles within 8 seconds).

### Dynamic recalibration

When RTC\_INITSTS.INITF=0, RTC\_CALIB register can update by using following steps:

- Wait RTC\_INITSTS.RECPF=0.
- A new value is written to the RTC\_CALIB, then RTC\_INITSTS.RECPF is automatically set to 1.
- The new calibration settings will take effect within 3 ck\_apre cycles after a data write to the RTC\_CALIB.

### 21.3.19 RTC Low Power Mode

The operating state of RTC in low power mode.

| Lower Power Mode | RTC Operating State                                       | Exit Low Power Mode   |
|------------------|---|---|
| SLEEP            | Normal operate  | RTC interrupt   |
| STOP             | Normal operate when the clock source of RTC is LSE or LSI | Alarm A, Alarm B, periodic wakeup, tamper event and timestamp event |

## 21.4 RTC Registers

### 21.4.1 RTC Register Overview

Table 21-2 RTC Register Overview

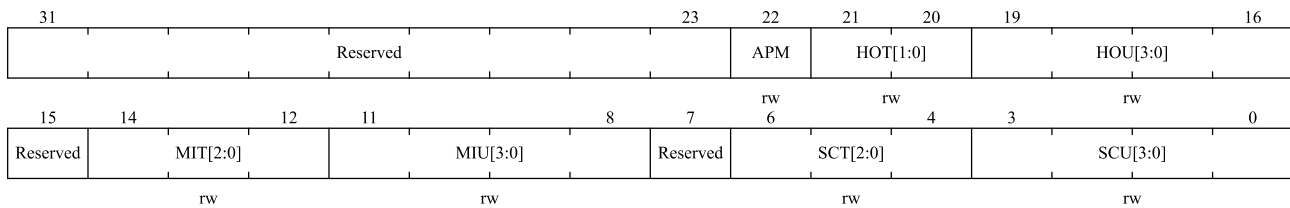
| Offset | Register    | 31       | 30 | 29 | 28 | 27 | 26 | 25 | 24 | 23 | 22 | 21       | 20       | 19 | 18       | 17       | 16 | 15       | 14       | 13       | 12       | 11 | 10       | 9        | 8        | 7        | 6        | 5        | 4 | 3        | 2 | 1 | 0 |   |   |   |   |   |
|--------|-------------|----------|----|----|----|----|----|----|----|----|----|----------|----------|----|----------|----------|----|----------|----------|----------|----------|----|----------|----------|----------|----------|----------|----------|---|----------|---|---|---|---|---|---|---|---|
| 000h   | RTC_TSH     | Reserved |    |    |    |    |    |    |    |    |    | APM      | HOT[1:0] |    |          | HOU[3:0] |    |          | Reserved | MIT[2:0] |          |    | MIU[3:0] |          |          | Reserved | SCT[2:0] |          |   | SCU[3:0] |   |   |   |   |   |   |   |   |
|        | Reset Value |          |    |    |    |    |    |    |    |    |    | 0        | 0        | 0  | 0        | 0        | 0  | 0        | 0        | 0        | 0        | 0  | 0        | 0        | 0        | 0        | 0        | 0        | 0 | 0        | 0 | 0 | 0 | 0 | 0 | 0 | 0 | 0 |
| 004h   | RTC_DATE    | Reserved |    |    |    |    |    |    |    |    |    | YRT[3:0] |          |    | YRU[3:0] |          |    | WDU[2:0] |          | MOT      | MOU[3:0] |    |          | Reserved | DAT[1:0] |          |          | DAU[3:0] |   |          |   |   |   |   |   |   |   |   |
|        | Reset Value |          |    |    |    |    |    |    |    |    |    | 0        | 0        | 0  | 0        | 0        | 0  | 0        | 0        | 0        | 0        | 1  | 0        | 0        | 0        | 0        | 0        | 1        | 0 | 0        | 0 | 0 | 0 | 0 | 0 | 1 |   |   |

| Offset | Register    | 31       | 30       | 29       | 28           | 27 | 26       | 25       | 24 | 23    | 22  | 21        | 20          | 19       | 18       | 17     | 16          | 15         | 14          | 13         | 12          | 11     | 10      | 9        | 8         | 7        | 6        | 5        | 4      | 3        | 2     | 1            | 0     |   |   |   |   |   |   |   |   |   |   |   |   |   |   |   |   |   |   |   |   |   |   |   |
|--------|-------------|----------|----------|----------|--------------|----|----------|----------|----|-------|-----|-----------|-------------|----------|----------|--------|-------------|------------|-------------|------------|-------------|--------|---------|----------|-----------|----------|----------|----------|--------|----------|-------|--------------|-------|---|---|---|---|---|---|---|---|---|---|---|---|---|---|---|---|---|---|---|---|---|---|---|
| 008h   | RTC_CTRL    | Reserved |          |          |              |    |          |          |    |       |     | COEN      | OUTSEL[1:0] | OPO      | CALOSEL  | BAKP   | SUTH        | ADTH       | TSIEN       | WTIEN      | ALBIEN      | ALAIEN | TSEN    | WTEN     | ALBEN     | ALAIEN   | Reserved | HFMT     | BYP    | REFCLKEN | TEDGE | WKUPSEL[2:0] |       |   |   |   |   |   |   |   |   |   |   |   |   |   |   |   |   |   |   |   |   |   |   |   |
|        | Reset Value |          |          |          |              |    |          |          |    |       |     | 0         | 0           | 0        | 0        | 0      | 0           | 0          | 0           | 0          | 0           | 0      | 0       | 0        | 0         | 0        | 0        | 0        | 0      | 0        | 0     | 0            | 0     | 0 | 0 | 0 | 0 | 0 | 0 |   |   |   |   |   |   |   |   |   |   |   |   |   |   |   |   |   |
| 00Ch   | RTC_INITSTS | Reserved |          |          |              |    |          |          |    |       |     |           |             |          |          |        | RECPF       | Reserved   | TAMZF       | TAMIF      | TISOVF      | TISF   | WTF     | ALBF     | ALAF      | INITM    | INITF    | RSYF     | INITSF | SHOPF    | WTWF  | ALBWF        | ALAWF |   |   |   |   |   |   |   |   |   |   |   |   |   |   |   |   |   |   |   |   |   |   |   |
|        | Reset Value |          |          |          |              |    |          |          |    |       |     |           |             |          |          |        | 0           | Reserved   | 0           | 0          | 0           | 0      | 0       | 0        | 0         | 0        | 0        | 0        | 0      | 0        | 0     | 0            | 0     | 0 | 0 | 0 | 0 | 0 | 0 | 0 | 0 | 0 | 0 | 0 | 0 | 0 | 0 | 0 |   |   |   |   |   |   |   |   |
| 010h   | RTC_PRE     | Reserved |          |          |              |    |          |          |    |       |     | DIVA[6:0] |             |          |          |        |             | Reserved   | DIVS[14:0]  |            |             |        |         |          |           |          |          |          |        |          |       |              |       |   |   |   |   |   |   |   |   |   |   |   |   |   |   |   |   |   |   |   |   |   |   |   |
|        | Reset Value |          |          |          |              |    |          |          |    |       |     | 1         | 1           | 1        | 1        | 1      | 1           | 1          | 1           | 1          | 1           | 1      | 1       | 1        | 1         | 1        | 1        | 1        | 1      | 1        | 1     | 1            | 1     | 1 | 1 | 1 | 1 | 1 | 1 | 1 | 1 | 1 |   |   |   |   |   |   |   |   |   |   |   |   |   |   |
| 014h   | RTC_WKUPT   | Reserved |          |          |              |    |          |          |    |       |     |           |             |          |          |        | WKUPT[15:0] |            |             |            |             |        |         |          |           |          |          |          |        |          |       |              |       |   |   |   |   |   |   |   |   |   |   |   |   |   |   |   |   |   |   |   |   |   |   |   |
|        | Reset Value |          |          |          |              |    |          |          |    |       |     |           |             |          |          |        | 1           | 1          | 1           | 1          | 1           | 1      | 1       | 1        | 1         | 1        | 1        | 1        | 1      | 1        | 1     | 1            | 1     | 1 | 1 | 1 | 1 | 1 | 1 | 1 | 1 | 1 | 1 | 1 | 1 | 1 | 1 | 1 |   |   |   |   |   |   |   |   |
| 01Ch   | RTC_ALARM   | MASK4    | WKDSEL   | DTT[1:0] |              |    | DTU[3:0] |          |    | MASK3 | APM | HOT[1:0]  |             | HOU[3:0] |          |        | MASK2       | MIT[2:0]   |             | MIU[3:0]   |             |        | MASK1   | SET[2:0] |           | SEU[3:0] |          |          |        |          |       |              |       |   |   |   |   |   |   |   |   |   |   |   |   |   |   |   |   |   |   |   |   |   |   |   |
|        | Reset Value | 0        | 0        | 0        | 0            | 0  | 0        | 0        | 0  | 0     | 0   | 0         | 0           | 0        | 0        | 0      | 0           | 0          | 0           | 0          | 0           | 0      | 0       | 0        | 0         | 0        | 0        | 0        | 0      | 0        | 0     | 0            | 0     | 0 | 0 | 0 |   |   |   |   |   |   |   |   |   |   |   |   |   |   |   |   |   |   |   |   |
| 020h   | RTC_ALARMB  | MASK4    | WKDSEL   | DTT[1:0] |              |    | DTU[3:0] |          |    | MASK3 | APM | HOT[1:0]  |             | HOU[3:0] |          |        | MASK2       | MIT[2:0]   |             | MIU[3:0]   |             |        | MASK1   | SET[2:0] |           | SEU[3:0] |          |          |        |          |       |              |       |   |   |   |   |   |   |   |   |   |   |   |   |   |   |   |   |   |   |   |   |   |   |   |
|        | Reset Value | 0        | 0        | 0        | 0            | 0  | 0        | 0        | 0  | 0     | 0   | 0         | 0           | 0        | 0        | 0      | 0           | 0          | 0           | 0          | 0           | 0      | 0       | 0        | 0         | 0        | 0        | 0        | 0      | 0        | 0     | 0            | 0     | 0 | 0 | 0 | 0 |   |   |   |   |   |   |   |   |   |   |   |   |   |   |   |   |   |   |   |
| 024h   | RTC_WRP     | Reserved |          |          |              |    |          |          |    |       |     |           |             |          |          |        |             |            |             |            |             |        |         |          | PKEY[7:0] |          |          |          |        |          |       |              |       |   |   |   |   |   |   |   |   |   |   |   |   |   |   |   |   |   |   |   |   |   |   |   |
|        | Reset Value |          |          |          |              |    |          |          |    |       |     |           |             |          |          |        |             |            |             |            |             |        |         |          | 0         | 0        | 0        | 0        | 0      | 0        | 0     | 0            | 0     | 0 | 0 | 0 | 0 | 0 | 0 | 0 | 0 | 0 | 0 | 0 | 0 | 0 | 0 | 0 | 0 | 0 | 0 | 0 | 0 | 0 | 0 | 0 |
| 028h   | RTC_SUBS    | Reserved |          |          |              |    |          |          |    |       |     |           |             |          |          |        | SS[15:0]    |            |             |            |             |        |         |          |           |          |          |          |        |          |       |              |       |   |   |   |   |   |   |   |   |   |   |   |   |   |   |   |   |   |   |   |   |   |   |   |
|        | Reset Value |          |          |          |              |    |          |          |    |       |     |           |             |          |          |        | 0           | 0          | 0           | 0          | 0           | 0      | 0       | 0        | 0         | 0        | 0        | 0        | 0      | 0        | 0     | 0            | 0     | 0 | 0 | 0 | 0 | 0 | 0 | 0 | 0 | 0 | 0 | 0 | 0 | 0 | 0 | 0 |   |   |   |   |   |   |   |   |
| 02Ch   | RTC_SCTRL   | ADIS     | Reserved |          |              |    |          |          |    |       |     |           |             |          |          |        |             | SUBF[14:0] |             |            |             |        |         |          |           |          |          |          |        |          |       |              |       |   |   |   |   |   |   |   |   |   |   |   |   |   |   |   |   |   |   |   |   |   |   |   |
|        | Reset Value | 0        |          |          |              |    |          |          |    |       |     |           |             |          |          |        |             | 0          | 0           | 0          | 0           | 0      | 0       | 0        | 0         | 0        | 0        | 0        | 0      | 0        | 0     | 0            | 0     | 0 | 0 | 0 | 0 | 0 | 0 | 0 | 0 | 0 | 0 | 0 | 0 | 0 | 0 |   |   |   |   |   |   |   |   |   |
| 030h   | RTC_TST     | Reserved |          |          |              |    |          |          |    |       |     | APM       | HOT[1:0]    |          | HOU[3:0] |        |             | Reserved   | MIT[2:0]    |            | MIU[3:0]    |        |         | Reserved | SET[2:0]  |          | SEU[3:0] |          |        |          |       |              |       |   |   |   |   |   |   |   |   |   |   |   |   |   |   |   |   |   |   |   |   |   |   |   |
|        | Reset Value |          |          |          |              |    |          |          |    |       |     | 0         | 0           | 0        | 0        | 0      | 0           | 0          | 0           | 0          | 0           | 0      | 0       | 0        | 0         | 0        | 0        | 0        | 0      | 0        | 0     | 0            | 0     | 0 | 0 | 0 | 0 | 0 | 0 | 0 | 0 | 0 |   |   |   |   |   |   |   |   |   |   |   |   |   |   |
| 034h   | RTC_TSD     | Reserved |          |          |              |    |          |          |    |       |     | YRT[3:0]  |             |          | YRU[3:0] |        |             | WJU[2:0]   |             | MOT        | MOU[3:0]    |        |         | Reserved | DAT[1:0]  |          | DAU[3:0] |          |        |          |       |              |       |   |   |   |   |   |   |   |   |   |   |   |   |   |   |   |   |   |   |   |   |   |   |   |
|        | Reset Value |          |          |          |              |    |          |          |    |       |     | 0         | 0           | 0        | 0        | 0      | 0           | 0          | 0           | 0          | 0           | 0      | 0       | 0        | 0         | 0        | 0        | 0        | 0      | 0        | 0     | 0            | 0     | 0 | 0 | 0 | 0 | 0 | 0 | 0 | 0 | 0 | 0 |   |   |   |   |   |   |   |   |   |   |   |   |   |
| 038h   | RTC_TSSS    | Reserved |          |          |              |    |          |          |    |       |     |           |             |          |          |        | SSE[15:0]   |            |             |            |             |        |         |          |           |          |          |          |        |          |       |              |       |   |   |   |   |   |   |   |   |   |   |   |   |   |   |   |   |   |   |   |   |   |   |   |
|        | Reset Value |          |          |          |              |    |          |          |    |       |     |           |             |          |          |        | 0           | 0          | 0           | 0          | 0           | 0      | 0       | 0        | 0         | 0        | 0        | 0        | 0      | 0        | 0     | 0            | 0     | 0 | 0 | 0 | 0 | 0 | 0 | 0 | 0 | 0 | 0 | 0 | 0 | 0 | 0 | 0 | 0 |   |   |   |   |   |   |   |
| 03Ch   | RTC_CALIB   | Reserved |          |          |              |    |          |          |    |       |     |           |             |          |          |        | CP          | CW8        | CW16        | Reserved   |             |        | CM[8:0] |          |           |          |          |          |        |          |       |              |       |   |   |   |   |   |   |   |   |   |   |   |   |   |   |   |   |   |   |   |   |   |   |   |
|        | Reset Value |          |          |          |              |    |          |          |    |       |     |           |             |          |          |        | 0           | 0          | 0           |            |             |        | 0       | 0        | 0         | 0        | 0        | 0        | 0      | 0        | 0     | 0            | 0     | 0 | 0 | 0 | 0 | 0 | 0 | 0 | 0 | 0 | 0 | 0 | 0 | 0 | 0 |   |   |   |   |   |   |   |   |   |
| 040h   | RTC_TMPCFG  | Reserved |          |          |              |    |          |          |    |       |     | TP2MF     | TP2NOE      | TP2INTEN | TP1MF    | TP1NOE | TP1INTEN    | TPPUDIS    | TPPRCH[1:0] | TPFLT[1:0] | TPFREQ[2:0] |        |         | TPTS     | Reserved  | TP2TRG   | TP2EN    | TP1INTEN | TP1TRG | TP1EN    |       |              |       |   |   |   |   |   |   |   |   |   |   |   |   |   |   |   |   |   |   |   |   |   |   |   |
|        | Reset Value |          |          |          |              |    |          |          |    |       |     | 0         | 0           | 0        | 0        | 0      | 0           | 0          | 0           | 0          | 0           | 0      | 0       | 0        | 0         | 0        | 0        | 0        | 0      | 0        | 0     | 0            | 0     | 0 | 0 | 0 | 0 | 0 | 0 | 0 | 0 | 0 | 0 |   |   |   |   |   |   |   |   |   |   |   |   |   |
| 044h   | RTC_ALRMAS  | Reserved |          |          | MASKSSA[3:0] |    |          | Reserved |    |       |     |           |             |          |          |        |             | SSV[14:0]  |             |            |             |        |         |          |           |          |          |          |        |          |       |              |       |   |   |   |   |   |   |   |   |   |   |   |   |   |   |   |   |   |   |   |   |   |   |   |
|        | Reset Value |          |          |          | 0            | 0  | 0        | 0        |    |       |     |           |             |          |          |        |             |            | 0           | 0          | 0           | 0      | 0       | 0        | 0         | 0        | 0        | 0        | 0      | 0        | 0     | 0            | 0     | 0 | 0 | 0 | 0 | 0 | 0 | 0 | 0 | 0 |   |   |   |   |   |   |   |   |   |   |   |   |   |   |
| 048h   | RTC_ALRMBSS | Reserved |          |          | MASKSSB[3:0] |    |          | Reserved |    |       |     |           |             |          |          |        |             | SSV[14:0]  |             |            |             |        |         |          |           |          |          |          |        |          |       |              |       |   |   |   |   |   |   |   |   |   |   |   |   |   |   |   |   |   |   |   |   |   |   |   |
|        | Reset Value |          |          |          | 0            | 0  | 0        | 0        |    |       |     |           |             |          |          |        |             |            | 0           | 0          | 0           | 0      | 0       | 0        | 0         | 0        | 0        | 0        | 0      | 0        | 0     | 0            | 0     | 0 | 0 | 0 | 0 | 0 | 0 | 0 | 0 | 0 | 0 | 0 |   |   |   |   |   |   |   |   |   |   |   |   |

### 21.4.2 RTC Calendar Time Register (RTC\_TSH)

Address offset: 0x00

Reset value: 0x0000 0000

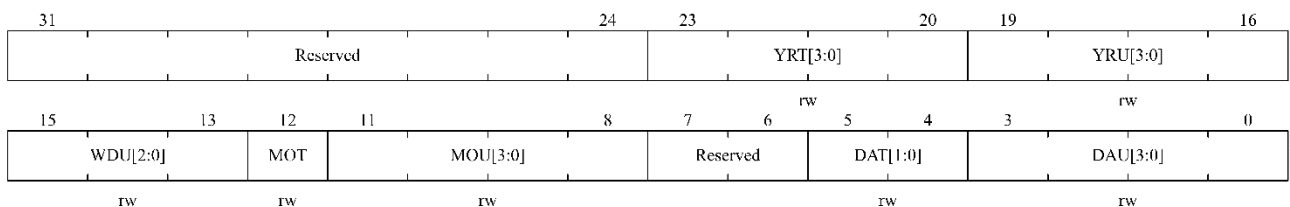


| Bit Field | Name       | Description   |
|-----------|------------|---|
| 31:23     | Reserved   | Reserved, the reset value must be maintained.                   |
| 22        | APM        | AM/PM format.<br>0: AM format or 24-hour format<br>1: PM format |
| 21:20     | HOT[1:0]   | Describes the hour tens value in BCD format                     |
| 19:16     | HOU[3:0]   | Describes the hour units value in BCD format                    |
| 15        | Reserved   | Reserved, the reset value must be maintained.                   |
| 14:12     | MIT [2: 0] | Describes the minute tens value in BCD format                   |
| 11:8      | MIU[3:0]   | Describes the minute units value in BCD format                  |
| 7         | Reserved   | Reserved, the reset value must be maintained.                   |
| 6:4       | SCT[2:0]   | Describes the second tens value in BCD format                   |
| 3:0       | SCU[3:0]   | Describes the second units value in BCD format                  |

### 21.4.3 RTC Calendar Date Register (RTC\_DATE)

Address offset: 0x04

Reset value: 0x0000 2101



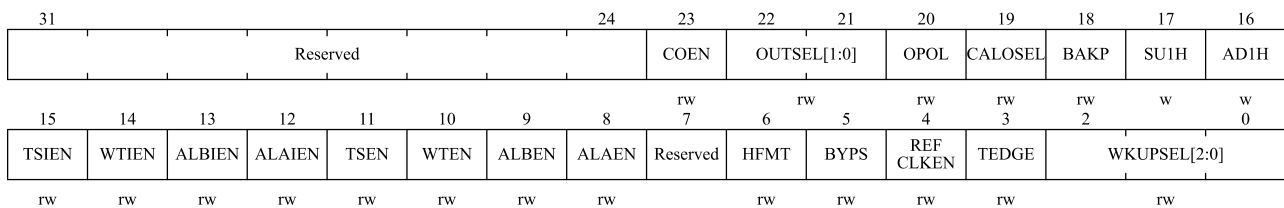
| Bit Field | Name     | Description   |
|-----------|----------|---|
| 31:24     | Reserved | Reserved, the reset value must be maintained.                                   |
| 23:20     | YRT[3:0] | Describes the year tens value in BCD format                                     |
| 19:16     | YRU[3:0] | Describes the year units value in BCD format                                    |
| 15:13     | WDU[2:0] | Describes which Week day<br>000: Forbidden<br>001: Monday<br>...<br>111: Sunday |
| 12        | MOT      | Describes the month tens value in BCD format                                    |

| Bit Field | Name     | Description                                   |
|-----------|----------|---|
| 11:8      | MOU[3:0] | Describes the month units value in BCD format |
| 7:6       | Reserved | Reserved, the reset value must be maintained. |
| 5:4       | DAT[1:0] | Describes the date tens value in BCD format   |
| 3:0       | DAU[3:0] | Describes the date units value in BCD format  |

#### 21.4.4 RTC Control Register (RTC\_CTRL)

Address offset: 0x08

Reset value: 0x0000 0000



| Bit Field | Name        | Description  |
|-----------|-------------|--|
| 31:24     | Reserved    | Reserved, the reset value must be maintained.  |
| 23        | COEN        | Calibration output enable<br>This bit controls RTC_CALIB output<br>0: Disable calibration output<br>1: Enable calibration output   |
| 22:21     | OUTSEL[1:0] | Output selection<br>These bits are used to select the alarm/wakeup output<br>00: Disable output<br>01: Enable Alarm A output<br>10: Enable Alarm B output<br>11: Enable Wakeup output  |
| 20        | OPOL        | Output polarity bit<br>This bit is used to configure the polarity of output.<br>0: Outputs high level when the selected output triggers(see OUTSEL[1:0])<br>1: Outputs low level when the selected output triggers(see OUTSEL[1:0])  |
| 19        | CALOSEL     | Calibration output selection<br>When RTC_CTRL.COEN=1, RTCCLK = 32.768KHz and prescale at their default value (RTC_PRE.DIVA[6:0]=127 and RTC_PRE.DIVS[14:0]=255).<br>0: Calibration output is 256 Hz<br>1: Calibration output is 1 Hz |
| 18        | BAKP        | Daylight saving time record<br>This bit is written by the user<br>0: Not record daylight saving time<br>1: Record daylight saving time   |
| 17        | SUIH        | Subtract 1 hour (winter time change)   |

| Bit Field | Name     | Description  |
|-----------|----------|--|
|           |          | 1 hour will be subtracted to the calendar time when the current hour value is not 0. This bit is always read as 0.<br>0: No effect.<br>1: Subtracts 1 hour to the current time.  |
| 16        | AD1H     | Add 1 hour (summer time change)<br>When this bit is set, 1 hour can be added to the calendar time. This bit is always read as.<br>0: No effect.<br>1: Adds 1 hour to the current time.                                 |
| 15        | TSIEN    | Time-stamp interrupt enable<br>0: Disable time-stamp interrupt.<br>1: Enable time-stamp interrupt.   |
| 14        | WTIEN    | Wakeup timer interrupt enable<br>0: Disable wakeup timer interrupt.<br>1: Enable wakeup timer interrupt.   |
| 13        | ALBIEN   | Alarm B interrupt enable<br>0: Disable Alarm B interrupt<br>1: Enable Alarm B Interrupt  |
| 12        | ALAIEN   | Alarm A interrupt enable<br>0: Disable Alarm A interrupt<br>1: Enable Alarm A interrupt  |
| 11        | TSEN     | Timestamp enable<br>0: Disable timestamp<br>1: Enable timestamp  |
| 10        | WTEN     | Wakeup timer enable<br>0: Disable wakeup timer<br>1: Enable wakeup timer   |
| 9         | ALBEN    | Alarm B enable<br>0: Disable Alarm B<br>1: Enable Alarm B  |
| 8         | ALAEN    | Alarm A enable<br>0: Disable Alarm A<br>1: Enable Alarm A  |
| 7         | Reserved | Reserved, the reset value must be maintained.  |
| 6         | HFMT     | Hour format bit<br>0: 24 hour format<br>1: Am/PM format  |
| 5         | BYPS     | Bypass values from the shadow registers<br>0: Calendar values are copied from the shadow registers, which are refreshed every two RTCCLK cycles.<br>1: Calendar values are copied directly from the calendar counters. |

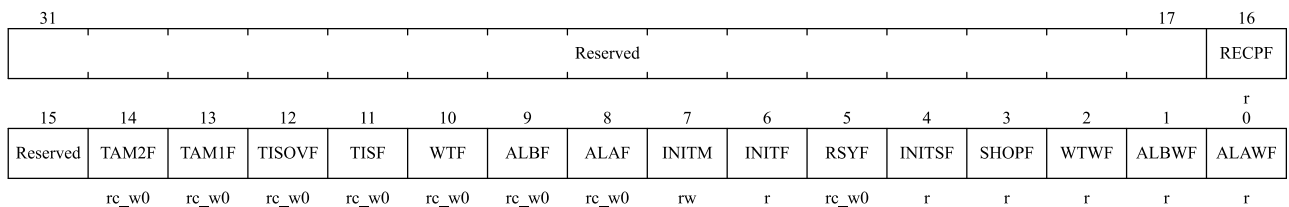


| Bit Field | Name         | Description  |
|-----------|--------------|--|
|           |              | <i>Note: If the frequency of the APB1 clock falls below seven times the frequency of RTCCLK, RTC_CTRL.BYPS bit must be set to '1'</i>  |
| 4         | REFCLKEN     | RTC_REFIN reference clock detection enable (50 or 60 Hz)<br>0: Disable RTC_REFIN detection<br>1: Enable RTC_REFIN detection<br><i>Note: RTC_PRE.DIVS must be 0x00FF</i>  |
| 3         | TEDGE        | Time-stamp event effective edge<br>0: Input rising edge creates a timestamp event<br>1: Input falling edge creates a timestamp event<br>TSEN need to be reset when TEDGE is changed to avoid unwanted RTC_INITSTS.TISF setting.  |
| 2:0       | WKUPSEL[2:0] | Wakeup clock selection<br>000: RTC clock is divided by 16<br>001: RTC clock is divided by 8<br>010: RTC clock is divided by 4<br>011: RTC clock is divided by 2<br>10x: ck_spre (usually 1Hz) clock is selected<br>11x: ck_spre (usually 1Hz) clock is selected and 2 <sup>16</sup> is added to the RTC_WKUPT.WKUPT counter. |

### 21.4.5 RTC Initial Status Register (RTC\_INITSTS)

Address offset: 0x0C

Reset value: 0x0000 0007



| Bit Field | Name     | Description   |
|-----------|----------|---|
| 31:17     | Reserved | Reserved, the reset value must be maintained.   |
| 16        | RECPF    | Recalibration pending flag<br>The RECPF status flag is automatically set to '1' when software writes to the RTC_CALIB register, indicating that the RTC_CALIB register is blocked. After the new calibration settings are processed, this bit returns to '0'. |
| 15        | Reserved | Reserved, the reset value must be maintained.   |
| 14        | TAM2F    | RTC_TAMP2 detection flag<br>This flag is set to '1' by hardware when a tamper event is detected on the RTC_TAMP2 input pin.<br>This flag can be cleared by software writing 0   |

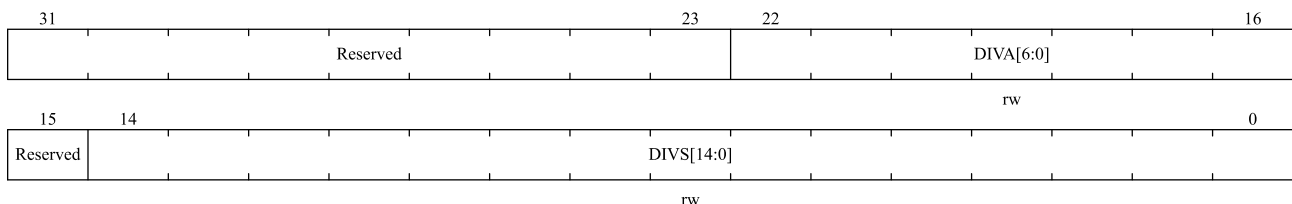
| Bit Field | Name   | Description   |
|-----------|--------|---|
| 13        | TAM1F  | <p>RTC_TAMP1 detection flag</p> <p>This flag is set to '1' by hardware when a tamper event is detected on the RTC_TAMP1 input pin.</p> <p>This flag can be cleared by software writing 0</p>  |
| 12        | TISOVF | <p>The time-stamp overflow flag</p> <p>This flag is set to '1' by hardware when a time-stamp event happens when TISF bit is set.</p> <p>This flag can be cleared by software writing 0. It is advised to check and clear TISOVF only after clearing the TISF bit. Otherwise, an overflow might not be noticed if a timestamp event occurs immediately before the TISF bit is being cleared.</p> |
| 11        | TISF   | <p>Time-stamp flag</p> <p>This flag is set to '1' by hardware when a time-stamp event happens.</p> <p>This flag can be cleared by software writing 0</p>  |
| 10        | WTF    | <p>Wake up timer flag</p> <p>This flag is set by hardware when the value of wakeup auto-reload counter reaches 0.</p> <p>This flag is cleared by software by writing 0.</p> <p>This flag must be cleared by software at least 1.5 RTCCLK periods before WTF is set again.</p>   |
| 9         | ALBF   | <p>Alarm B flag</p> <p>This flag is set to '1' by hardware when the time/date registers value match the Alarm B register values.</p> <p>This flag can be cleared by software writing 0</p>  |
| 8         | ALAF   | <p>Alarm A flag</p> <p>This flag is set to '1' by hardware when the time/date registers value match the Alarm A register values.</p> <p>This flag can be cleared by software writing 0</p>  |
| 7         | INITM  | <p>Enter initialization mode</p> <p>0: Free running mode</p> <p>1: Enter initialization mode and set calendar time value, date value, and prescale value.</p>   |
| 6         | INITF  | <p>Initialization flag</p> <p>RTC is in initialization state when this bit is '1', and calendar time, date and prescale value can be updated.</p> <p>0: Calendar time, date and prescale value can not be updated</p> <p>1: Calendar time, date and prescale value can be updated</p>   |
| 5         | RSYF   | <p>Register synchronization flag</p> <p>This flag is set to '1' by hardware when the calendar value are copied into the shadow registers. This bit is cleared by hardware when in initialization mode, while a shift operation is pending (SHOPF=1), or when in bypass shadow</p>   |

| Bit Field | Name   | Description   |
|-----------|--------|---|
|           |        | register mode (RTC_CTRL.BYPS=1). This bit can also be cleared by software. It is cleared either by software or by hardware in initialization mode.<br>0: Calendar shadow register not yet synchronized<br>1: Calendar shadow register synchronized  |
| 4         | INITSF | Initialization status flag<br>This flag is set to '1' by hardware when the calendar year field is different from 0 (which is the RTC domain reset state).<br>0: Calendar has not been initialized<br>1: Calendar has been initialized   |
| 3         | SHOPF  | Shift operation pending flag<br>This flag is set to '1' by hardware as soon as a shift operation is initiated by a write to the RTC_SCTRL register. It is cleared by hardware when the corresponding shift operation has been completed, note that writing to the SHOPF bit has no effect.<br>0: No shift operation is pending<br>1: A shift operation is pending |
| 2         | WTWF   | Wakeup timer write flag<br>0: Wakeup timer configuration update is not allowed<br>1: Wakeup timer configuration update is allowed   |
| 1         | ALBWF  | Alarm B write flag<br>This flag is set to '1' by hardware when Alarm B values can be changed, after the RTC_CTRL.ALBEN bit has been set to 0.<br>0: Alarm B update is not allowed<br>1: Alarm B update is allowed   |
| 0         | ALAWF  | Alarm A write flag.<br>This flag is set to '1' by hardware when Alarm A values can be changed, after the RTC_CTRL.ALAEN bit has been set to 0.<br>0: Alarm A update is not allowed<br>1: Alarm A update is allowed  |

### 21.4.6 RTC Prescaler Register (RTC\_PRE)

Address offset: 0x10

Reset value: 0x007F 00FF

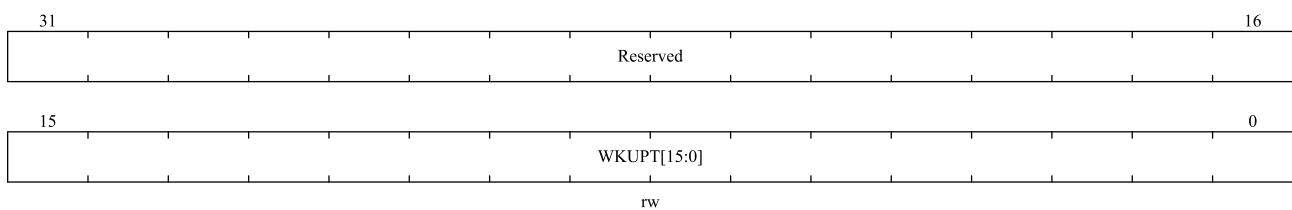


| Bit Field | Name       | Description  |
|-----------|------------|--|
| 31:23     | Reserved   | Reserved, the reset value must be maintained.                                    |
| 22:16     | DIVA[6:0]  | Asynchronous prescaler factor<br>$f_{ck\_apre} = RTCCLK / (DIVA[6:0] + 1)$       |
| 15        | Reserved   | Reserved, the reset value must be maintained.                                    |
| 14:0      | DIVS[14:0] | Synchronous prescaler factor<br>$f_{ck\_spre} = f_{ck\_apre} / (DIVS[14:0] + 1)$ |

### 21.4.7 RTC Wakeup Timer Register (RTC\_WKUPT)

Address offset: 0x14

Reset value: 0x0000 FFFF

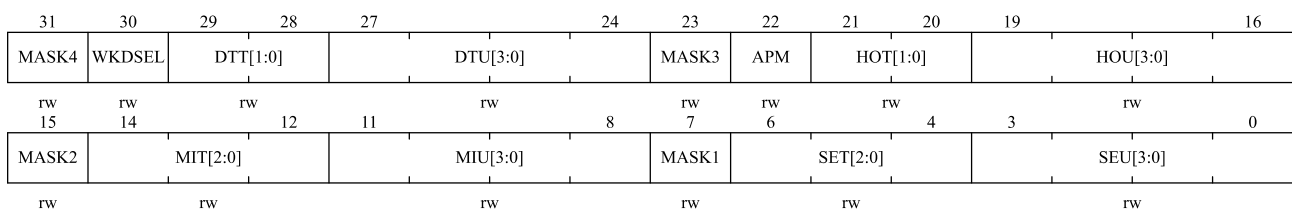


| Bit Field | Name        | Description  |
|-----------|-------------|--|
| 31:16     | Reserved    | Reserved, the reset value must be maintained.  |
| 15:0      | WKUPT[15:0] | Wake up auto-reload value bits<br>The RTC_INITSTS.WTF flag is set every (WKUPT[15:0] + 1) ck_wut cycles when the RTC_CTRL.WTEN=1. The wakeup timer becomes 17-bits When RTC_CTRL.WKUPSEL[2]=1.<br><i>Note:</i><br><i>This register change (such as the second setting or later Settings) needs to be changed in the wakeup interrupt, otherwise the changed Settings will not take effect immediately, but will take effect after the next wakeup;</i><br><i>In particular, when RTC_CTRL.WKUPSEL[2:0] is set to 010, the modified setting does not take effect immediately, but will take effect after wake up in the next cycle.</i> |

### 21.4.8 RTC Alarm A Register (RTC\_ALARMa)

Address offset: 0x1C

Reset value: 0x0000 0000

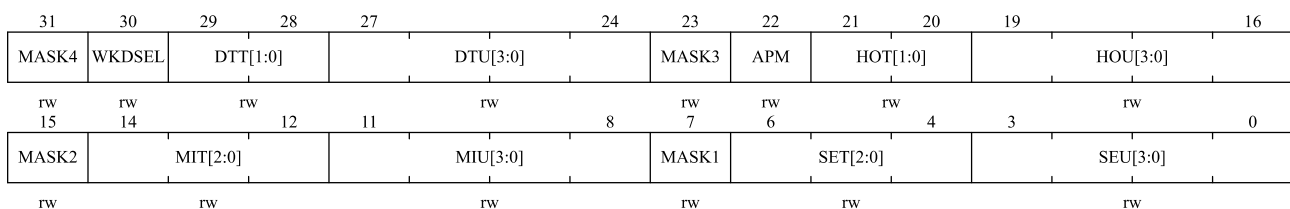


| Bit Field | Name     | Description   |
|-----------|----------|---|
| 31        | MASK4    | Alarm date mask<br>0: Date/day match<br>1: Date/day not match   |
| 30        | WKDSEL   | Week day selection<br>0: DTU[3:0] represents the date units<br>1: DTU[3:0] represents week day only. DTT[1:0] is not considered |
| 29:28     | DTT[1:0] | Describes the date tens value in BCD format   |
| 27:24     | DTU[3:0] | Describes the date units value in BCD format  |
| 23        | MASK3    | Alarm hours mask<br>0: Hours match<br>1: Hours not match  |
| 22        | APM      | AM/PM notation<br>0: AM or 24 hours format<br>1: PM format  |
| 21:20     | HOT[1:0] | Describes the hour tens value in BCD format   |
| 19:16     | HOU[3:0] | Describes the hour units value in BCD format  |
| 15        | MASK2    | Alarm minutes mask<br>0: Minutes match<br>1: Minutes not match  |
| 14:12     | MIT[2:0] | Describes the minute tens value in BCD format   |
| 11:8      | MIU[3:0] | Describes the minute units value in BCD format  |
| 7         | MASK1    | Alarm seconds mask<br>0: Seconds match<br>1: Seconds not match  |
| 6:4       | SET[2:0] | Describes the second tens value in BCD format   |
| 3:0       | SEU[3:0] | Describes the second units value in BCD format  |

#### 21.4.9 RTC Alarm B Register (RTC\_ALARMb)

Address offset: 0x20

Reset value: 0x0000 0000



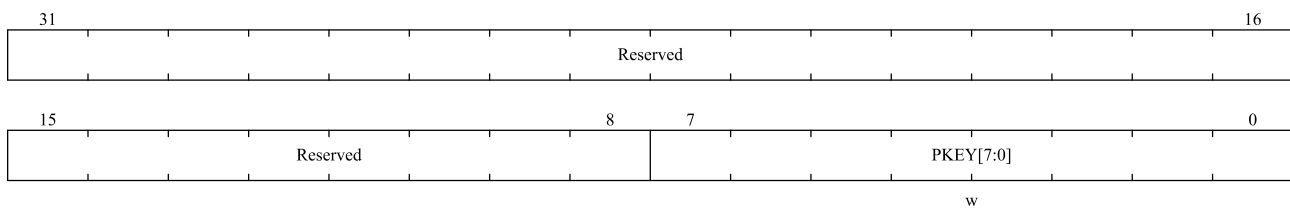
| Bit Field | Name  | Description   |
|-----------|-------|---|
| 31        | MASK4 | Alarm date mask<br>0: Date/day match<br>1: Date/day not match |

| Bit Field | Name     | Description   |
|-----------|----------|---|
| 30        | WKDSEL   | Week day selection<br>0: DTU[3:0] represents the date units<br>1: DTU[3:0] represents week day only. DTT[1:0] is not considered |
| 29:28     | DTT[1:0] | Describes the date tens value in BCD format   |
| 27:24     | DTU[3:0] | Describes the date units value in BCD format  |
| 23        | MASK3    | Alarm hours mask<br>0: Hours match<br>1: Hours not match  |
| 22        | APM      | AM/PM notation<br>0: AM or 24 hours format<br>1: PM format  |
| 21:20     | HOT[1:0] | Describes the hour tens value in BCD format   |
| 19:16     | HOU[3:0] | Describes the hour units value in BCD format  |
| 15        | MASK2    | Alarm minutes mask<br>0: Minutes match<br>1: Minutes not match  |
| 14:12     | MIT[2:0] | Describes the minute tens value in BCD format   |
| 11:8      | MIU[3:0] | Describes the minute units value in BCD format  |
| 7         | MASK1    | Alarm seconds mask<br>0: Seconds match<br>1: Seconds not match  |
| 6:4       | SET[2:0] | Describes the second tens value in BCD format   |
| 3:0       | SEU[3:0] | Describes the second units value in BCD format  |

#### 21.4.10 RTC Write Protection Register (RTC\_WRP)

Address offset: 0x24

Reset value: 0x0000 0000

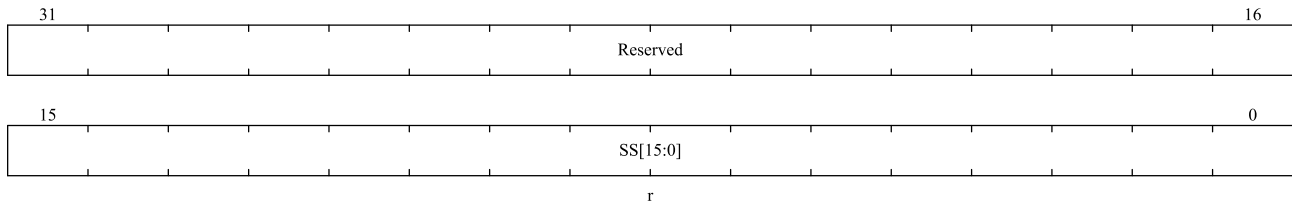


| Bit Field | Name      | Description   |
|-----------|-----------|---|
| 31:8      | Reserved  | Reserved, the reset value must be maintained.   |
| 7:0       | PKEY[7:0] | Write protection key<br>Reading this byte always returns 0x00.<br>For detail on how to unlock RTC register write protection, see chapter RTC register write protection. |

### 21.4.11 RTC Sub-second Register (RTC\_SUBS)

Address offset: 0x28

Reset value: 0x0000 0000

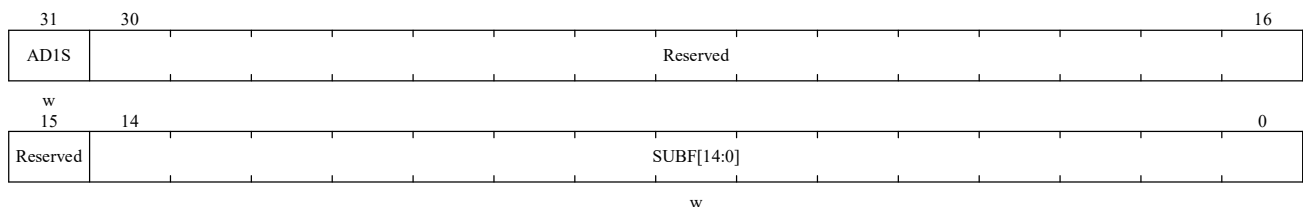


| Bit Field | Name     | Description  |
|-----------|----------|--|
| 31:16     | Reserved | Reserved, the reset value must be maintained.  |
| 15:0      | SS[15:0] | Sub-second bit.<br>This value is the value of the synchronous prescaler counter. This sub-second value is calculated by the below formula:<br>Sub-second value = (RTC_PRE.DIVS[14:0]-SS)/( RTC_PRE.DIVS[14:0]+1)<br><i>Note: SS[15:0] can be larger than RTC_PRE.DIVS[14:0] only after the shift operation is finished. In this case, the correct time/date is one second slower than the time/date indicated by RTC_TSH/RTC_DATE.</i> |

### 21.4.12 RTC Shift Control Register (RTC\_SCTRL)

Address offset: 0x2C

Reset value: 0x0000 0000



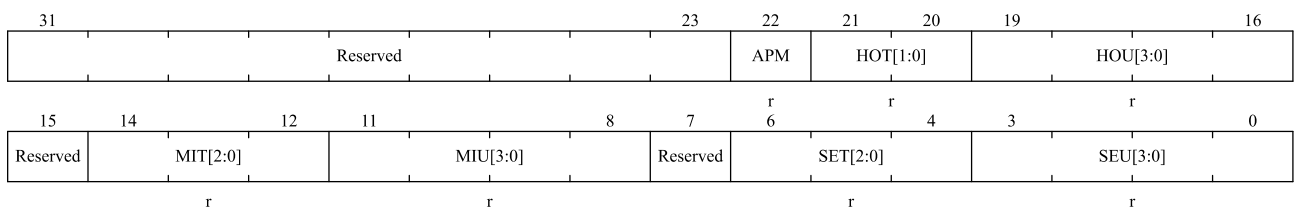
| Bit Field | Name       | Description  |
|-----------|------------|--|
| 31        | AD1S       | Add one second<br>0: No add one second.<br>1: Add one second to the clock/calendar<br>This bit can only be written and read as zero. Writing to this bit does not have an impact when RTC_INITSTS.SHOPF=1.   |
| 30:15     | Reserved   | Reserved, the reset value must be maintained.  |
| 14:0      | SUBF[14:0] | Subtract a fraction of a second<br>There bits can only be written and read as zero.. Writing to this bit does not have an impact when RTC_INITSTS.SHOPF=1. The value which is written to SUBF is added to the synchronous prescaler counter, and the clock will delay: |

| Bit Field | Name | Description  |
|-----------|------|--|
|           |      | $Delay (seconds) = (SUBF[14:0]+1) / (DIVS[14:0] + 1)$<br>AD1S bit can be used together with the SUBF[14:0]bits:<br>$Advance (seconds) = (1 - ((SUBF[14:0] + 1) / (DIVS[14:0] + 1)))$<br><i>Note: RTC_INITSTS.RSYF bit will be cleared when write SUBF[14:0]. When RTC_INITSTS.RSYF=1, the shadow registers have been updated with the shifted time.</i><br>When AD1S is set to 1, SUBF[14:0] cannot be all 0 |

### 21.4.13 RTC Timestamp Time Register (RTC\_TST)

Address offset: 0x30

Reset value: 0x0000 0000

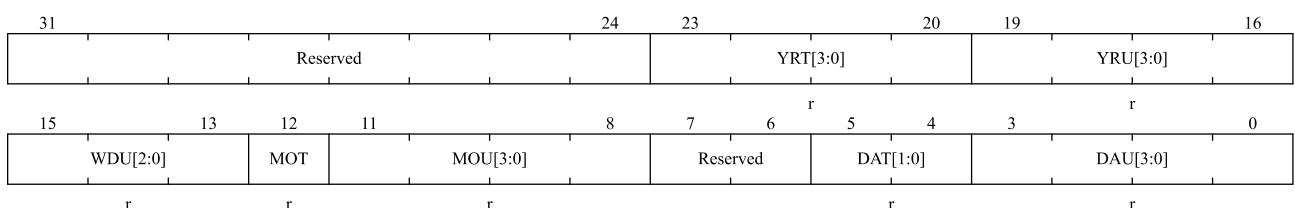


| Bit Field | Name     | Description                                       |
|-----------|----------|---|
| 31:23     | Reserved | Reserved, the reset value must be maintained.     |
| 22        | APM      | AM/PM notation<br>0: AM or 24-hour clock<br>1: PM |
| 21:20     | HOT[1:0] | Describes the hour tens value in BCD format       |
| 19:16     | HOU[3:0] | Describes the hour units value in BCD format      |
| 15        | Reserved | Reserved. Must be kept at the reset value         |
| 14:12     | MIT[2:0] | Describes the minute tens value in BCD format     |
| 11:8      | MIU[3:0] | Describes the minute units value in BCD format    |
| 7         | Reserved | Reserved, the reset value must be maintained.     |
| 6:4       | SET[2:0] | Describes the second tens value in BCD format     |
| 3:0       | SEU[3:0] | Describes the second units value in BCD format    |

### 21.4.14 RTC Timestamp Date Register (RTC\_TSD)

Address offset: 0x34

Reset value: 0x0000 0000



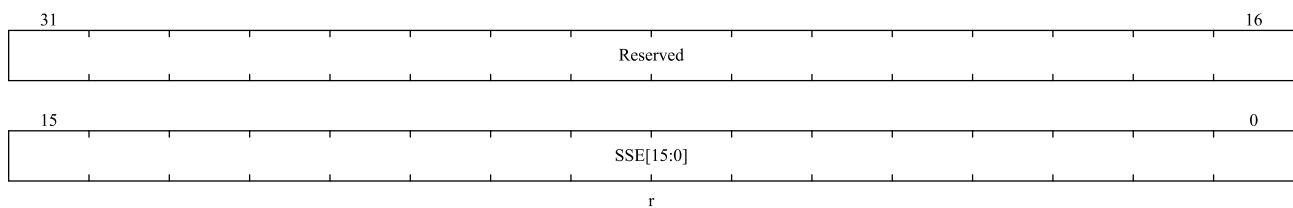


| Bit Field | Name     | Description   |
|-----------|----------|---|
| 31:24     | Reserved | Reserved, the reset value must be maintained.                                   |
| 23:20     | YRT[3:0] | Describes the year tens value in BCD format                                     |
| 19:16     | YRU[3:0] | Describes the year units value in BCD format                                    |
| 15:13     | WDU[2:0] | Describes which Week day<br>000: Forbidden<br>001: Monday<br>...<br>111: Sunday |
| 12        | MOT      | Describes the month tens value in BCD format                                    |
| 11:8      | MOU[3:0] | Describes the month units value in BCD format                                   |
| 7:6       | Reserved | Reserved, the reset value must be maintained.                                   |
| 5:4       | DAT[1:0] | Describes the date tens value in BCD format                                     |
| 3:0       | DAU[3:0] | Describes the date units value in BCD format                                    |

### 21.4.15 RTC Timestamp Sub-second Register (RTC\_TSSS)

Address offset: 0x38

Reset value: 0x0000 0000

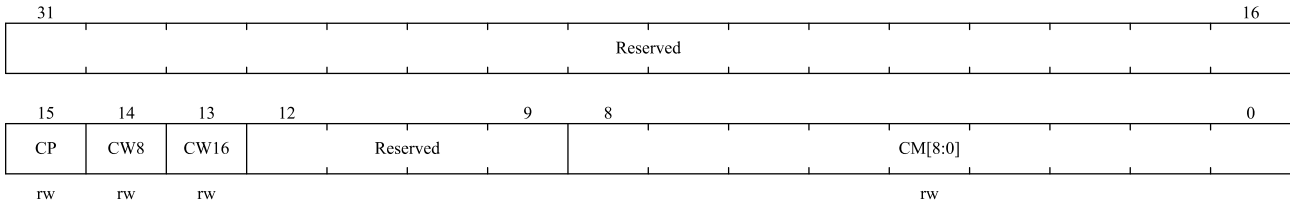


| Bit Field | Name      | Description  |
|-----------|-----------|--|
| 31:16     | Reserved  | Reserved, the reset value must be maintained.  |
| 15:0      | SSE[15:0] | Sub second value<br>SSE[15:0] is the value in the synchronous prescaler counter. The fraction of a second is provided by the formula below:<br>Second fraction = (RTC_PRE.DIVS[14:0] - SSE) / (RTC_PRE.DIVS[14:0] + 1)<br><i>Note: SSE can be larger than DIVS only after a shift operation. In that case, the correct time/date is one second less than as indicated by RTC_TSH/RTC_DATE.</i> |

### 21.4.16 RTC Calibration Register (RTC\_CALIB)

Address offset: 0x3C

Reset value: 0x0000 0000

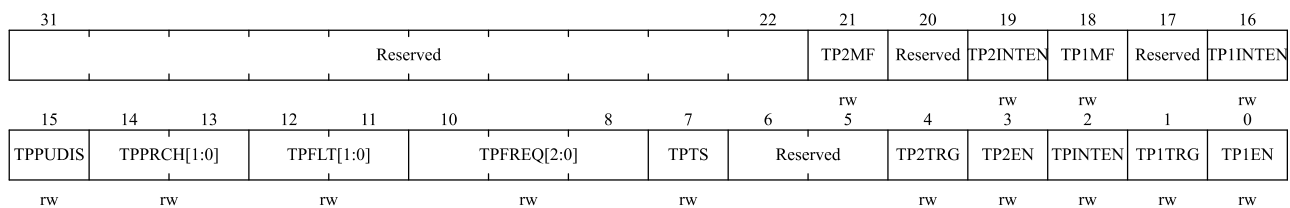


| Bit Field | Name     | Description  |
|-----------|----------|--|
| 31:16     | Reserved | Reserved, the reset value must be maintained.  |
| 15        | CP       | Increase frequency of RTC by 488.5 ppm<br>This feature is intended to be used along with CM[8:0]. When RTCCLK frequency is 32768 Hz, the number of RTCCLK pulses added during a 32-second window is ((512 * CP) – CM[8:0]).<br>0: No add pulse.<br>1: One RTCCLK pulse is inserted every 2 <sup>11</sup> pulses. |
| 14        | CW8      | Select an 8-second calibration cycle period<br>0: Not effect.<br>1: Select an 8-second calibration period.<br>When CW8 is set to ‘1’, the 8-second calibration cycle period is selected.<br><i>Note: when CW8 = 1, CM[1:0] will always be '00'</i>   |
| 13        | CW16     | To select a 16-second calibration cycle period<br>0: Not effect.<br>1: Select a calibration period of 16 seconds. If CW8 = 1, this bit cannot be set to 1.<br><i>Note: when CW16 = 1, CM[0] will always be '0'</i>   |
| 12:9      | Reserved | Reserved, the reset value must be maintained.  |
| 8:0       | CM[8:0]  | Negative calibration bits<br>The number of mask pulse out of 2 <sup>20</sup> RTCCLK pulses. This effectively decreases the frequency of the calendar with a resolution of 0.9537 ppm.  |

**21.4.17 RTC Tamper Configuration Register (RTC\_TMP\_CFG)**

Address offset: 0x40

Reset value: 0x0000 0000



| Bit Field | Name     | Description                                   |
|-----------|----------|---|
| 31:22     | Reserved | Reserved, the reset value must be maintained. |
| 21        | TP2MF    | Tamper 2 mask flag                            |

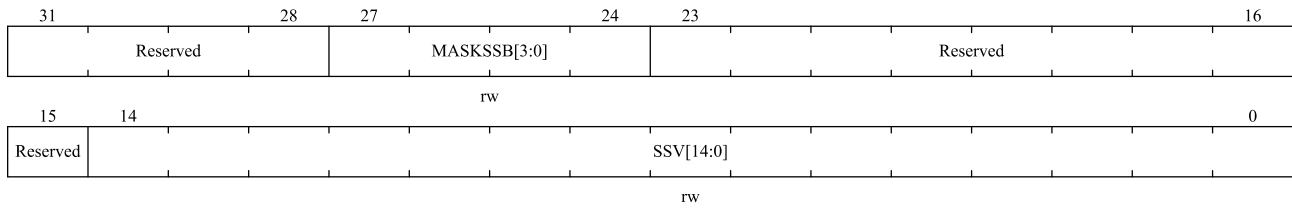
| Bit Field | Name        | Description  |
|-----------|-------------|--|
|           |             | 0: Not mask tamper 2 event.<br>1: Mask tamper 2 event.<br><i>Note: The Tamper 2 interrupt must not be enabled when TP2MF is set.</i>   |
| 20        | Reserved    | Reserved, the reset value must be maintained.  |
| 19        | TP2INTEN    | Tamper 2 interrupt enable<br>0: Disable tamper 2 interrupt when TPINTEN = 0.<br>1: Enabled tamper 2 interrupt  |
| 18        | TP1MF       | Tamper 1 mask flag<br>0: Not mask tamper 1 event.<br>1: Mask tamper 1 event.<br><i>Note: The Tamper 1 interrupt must not be enabled when TP1MF is set.</i>   |
| 17        | Reserved    | Reserved, the reset value must be maintained.  |
| 16        | TP1INTEN    | Tamper 1 interrupt enable<br>0: Disable tamper 1 interrupt when TPINTEN = 0.<br>1: Enabled tamper 1 interrupt  |
| 15        | TPPUDIS     | RTC_TAMPx Pull-up disable bit.<br>0: Enable precharge RTC_TAMPx pins before each sampling.<br>1: Disable precharge RTC_TAMPx pins  |
| 14:13     | TPPRCH[1:0] | RTC_TAMPx Precharge duration.<br>These bits determine the the precharge time before each sampling.<br>0x0: 1 RTCCLK cycles<br>0x1: 2 RTCCLK cycles<br>0x2: 4 RTCCLK cycles<br>0x3: 8 RTCCLK cycles   |
| 12:11     | TPFLT[1:0]  | RTC_TAMPx filter count<br>These bits determine the number of consecutive samples when occur active level.<br>0x0: Triggers a tamper event at the active level.<br>0x1: Triggers a tamper event after 2 consecutive samples at the active level.<br>0x2: Triggers a tamper event after 4 consecutive samples at the active level.<br>0x3: Triggers a tamper event after 8 consecutive samples at the active level.                      |
| 10:8      | TPFREQ[2:0] | Tamper sampling frequency<br>This bit determines the frequency at the each RTC_TAMPx input is sampled.<br>0x0: Sampling once every 32768 RTCCLK (1 Hz when RTCCLK = 32.768 KHz).<br>0x1: Sampling once every 16384 RTCCLK.<br>0x2: Sampling once every 8192 RTCCLK.<br>0x3: Sampling once every 4096 RTCCLK.<br>0x4: Sampling once every 2048 RTCCLK.<br>0x5: Sampling once every 1024 RTCCLK.<br>0x6: Sampling once every 512 RTCCLK. |

| Bit Field | Name     | Description   |
|-----------|----------|---|
|           |          | 0x7: Sampling once every 256 RTCCLK.  |
| 7         | TPTS     | Tamper event trigger timestamp<br>0: Disable tamper event trigger timestamp<br>1: Enable tamper event trigger timestamp<br>TPTS is valid even if TSEN=0 in the RTC_CTRL register.   |
| 6:5       | Reserved | Reserved, the reset value must be maintained.   |
| 4         | TP2TRG   | Tamper 2 event trigger edge<br>if TPFLT[1:0] != 00, tamper detection is in level mode:<br>0: low level trigger a tamper detection event.<br>1: high level trigger a tamper detection event.<br>if TPFLT = 00, tamper detection is in edge mode:<br>0: Rising edge trigger a tamper detection event.<br>1: Falling edge trigger a tamper detection event |
| 3         | TP2EN    | Tamper 2 detection enable<br>0: Disable tamper detection<br>1: Enable tamper detection  |
| 2         | TPINTEN  | Tamper event interrupt enable.<br>0: Disable tamper interrupt<br>1: Enable tamper interrupt<br><i>Note: This bit enables the interrupt of all tamper pins events, regardless of TPxINTEN level. If this bit is cleared, each tamper event interrupt can be individually enabled by setting TPxINTEN.</i>  |
| 1         | TP1TRG   | Tamper 1 event trigger edge<br>if TPFLT[1:0] != 00, tamper detection is in level mode:<br>0: low level trigger a tamper detection event.<br>1: high level trigger a tamper detection event.<br>if TPFLT = 00, tamper detection is in edge mode:<br>0: Rising edge trigger a tamper detection event.<br>1: Falling edge trigger a tamper detection event |
| 0         | TP1EN    | Tamper 1 detection enable<br>0: Disable tamper detection<br>1: Enable tamper detection  |

#### 21.4.18 RTC Alarm A Sub-second Register (RTC\_ALRMSS)

Address offset: 0x44

Reset value: 0x0000 0000

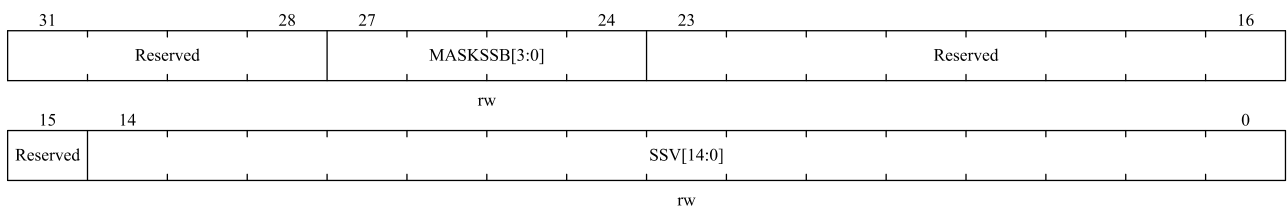


| Bit Field | Name         | Description   |
|-----------|--------------|---|
| 31:28     | Reserved     | Reserved, the reset value must be maintained.   |
| 27:24     | MASKSSB[3:0] | Mask the most significant bit from this bits.<br>0x0: No comparison on sub seconds for Alarm. The alarm is set when the seconds unit is incremented (assuming that the rest of the fields match).<br>0x1: Only SSV[0] is compared and other bits are not compared.<br>0x2: Only SSV[1:0] are compared and other bits are not compared.<br>0x3: Only SSV[2:0] are compared and other bits are not compared.<br>...<br>0xC: Only SSV[11:0] are compared and other bits are not compared.<br>0xD: Only SSV[12:0] are compared and other bits are not compared.<br>0xE: Only SSV[13:0] are compared and other bits are not compared.<br>0xF: SSV[14:0] are compared<br>Synchronization counter RTC_SUBS.SS[15] bit is never compared. |
| 23:15     | Reserved     | Reserved, the reset value must be maintained.   |
| 14:0      | SSV[14:0]    | Sub seconds value<br>This value is compared with the synchronous prescaler counter RTC_SUBS.SS[14:0], and bit number of compared is controlled by MASKSSB[3:0].   |

**21.4.19 RTC Alarm B Sub-second Register (RTC\_ALRMBSS)**

Address offset: 0x48

Reset value: 0x0000 0000



| Bit Field | Name         | Description  |
|-----------|--------------|--|
| 31:28     | Reserved     | Reserved, the reset value must be maintained.  |
| 27:24     | MASKSSB[3:0] | Mask the most significant bit from this bits.<br>0x0: No comparison on sub seconds for Alarm. The alarm is set when the seconds unit is incremented (assuming that the rest of the fields match).<br>0x1: Only SSV[0] is compared and other bits are not compared. |

| Bit Field | Name      | Description  |
|-----------|-----------|--|
|           |           | 0x2: Only SSV[1:0] are compared and other bits are not compared.<br>0x3: Only SSV[2:0] are compared and other bits are not compared.<br>...<br>0xC: Only SSV[11:0] are compared and other bits are not compared.<br>0xD: Only SSV[12:0] are compared and other bits are not compared.<br>0xE: Only SSV[13:0] are compared and other bits are not compared.<br>0xF: SSV[14:0] are compared.<br>Synchronization counter RTC_SUBS.SS[15] bit is never compared. |
| 23:15     | Reserved  | Reserved, the reset value must be maintained.  |
| 14:0      | SSV[14:0] | Sub seconds value<br>This value is compared with the synchronous prescaler counter<br>RTC_SUBS.SS[14:0], and bit number of compared is controlled by<br>MASKSSB[3:0].  |

## 22 Operational Amplifier (OPAMP)

The OPAMP module can be flexibly configured, suitable for applications such as independent operational programmable gain amplifier (PGA) mode and follower mode. The input range of OPAMP is 0V to  $V_{DDA}$  and the output range is 0.1V to  $V_{DDA}-0.1V$ . The output of the OPAMP is internally connected to the input channel of the ADC for analog signal measurement.

### 22.1 OPAMP Features

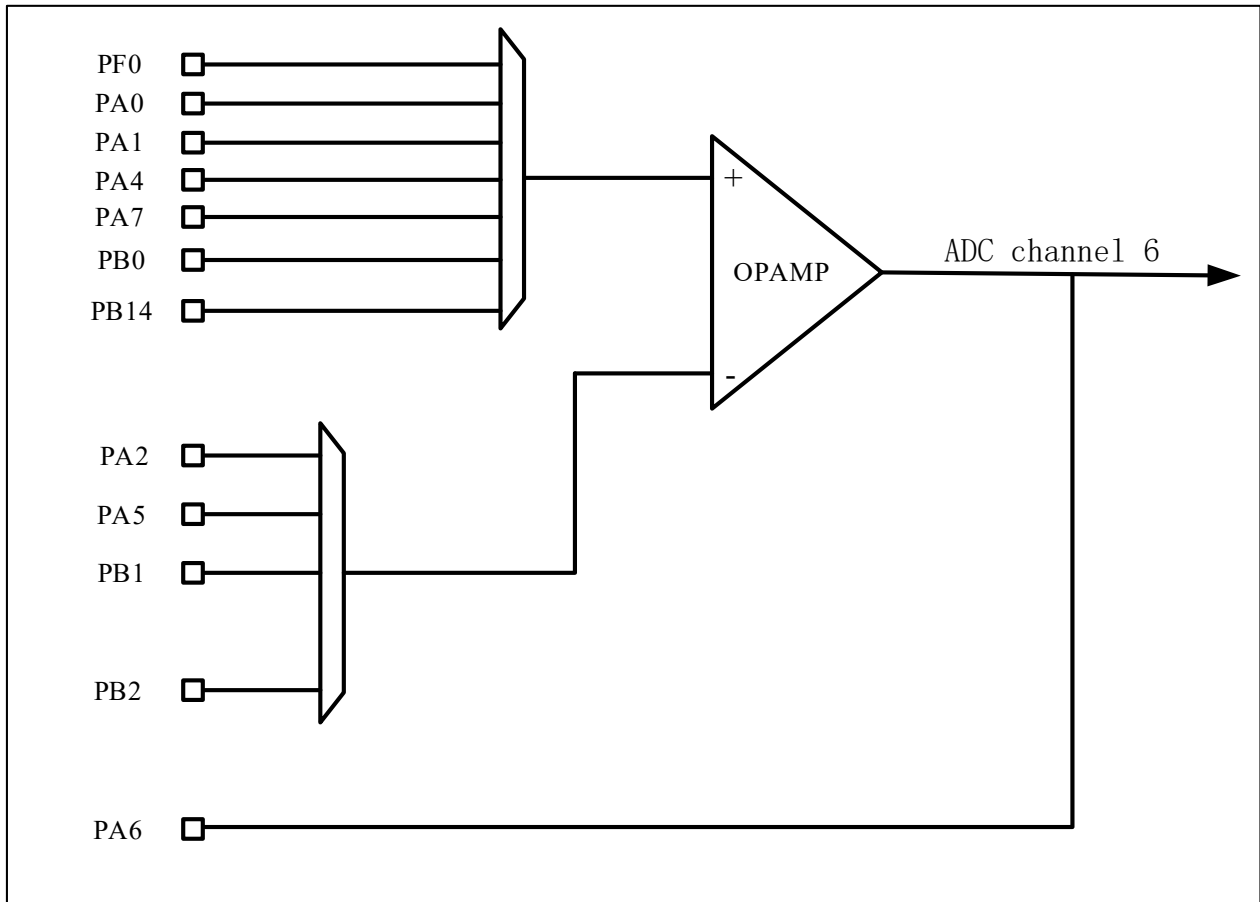
- Supports rail-to-rail input, the input range is 0 to  $V_{DDA}$ , and the output range is 0.1 to  $V_{DDA}-0.1$  programmable gain
- Can be configured as instrument amplifiers through external resistance connections
- Multiple operating modes can be configured:
  - Independent operational amplifier mode (all ports are led out, and the amplification factor can be set through the external resistor)
  - Voltage follow
  - Forward/reverse programmable gain amplifier
- Programmable gain can be set to 2X, 4X, 8X, 16X, 32X
- Gain-bandwidth:2.5MHz
- Supports TIM1\_CC6 automatically switches the input PIN of OPAMP
- Supports independent write protection

#### 22.1.1 OPAMP Function Description

The OPAMP can be configured to various PGA modes through register selection, and can also be configured as the OPAMP function for the user to use external components. The output of the OPAMP can be used as the input channel to the ADC. The OPAMP output is connected to the analog channel of the ADC as follows.

The output of OPAMP is connected to analog input Channel 6 of ADC.

**Figure 22-1 Block Diagram of OPAMP Connection Diagram**



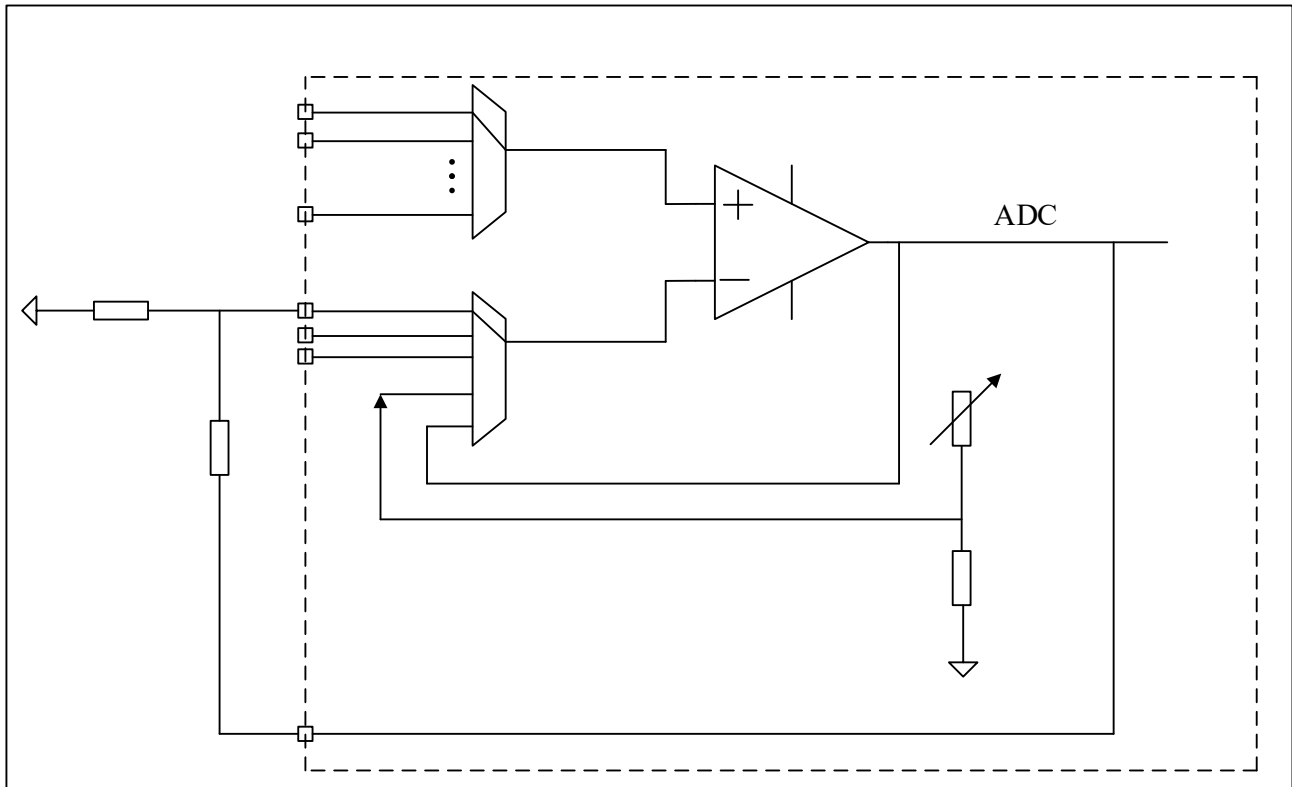
## 22.2 OPAMP Operating Mode

### 22.2.1 External Gain Mode

The external gain mode means that the gain factor is determined by the connected resistance and capacitance. When `OPAMP_CS.MOD = 2'b00` or `2'b01`, OPAMP operates in the external gain mode, `OPAMAP_CS.VPSSEL` or `OPAMAP_CS.VPSEL` selects non-inverted input, and `OPAMAP_CS.VMSSEL` or `OPAMAP_CS.VMSEL` selects inverted input. An external resistor is used to form a closed-loop amplification system. As shown in the figure below, thenon inverted terminal, inverted terminal and output terminal of the OPAMP are all connected to the external ports, and the amplification factor is determined by the external resistance-capacitance network.



Figure 22-2 OPAMP External Gain Mode



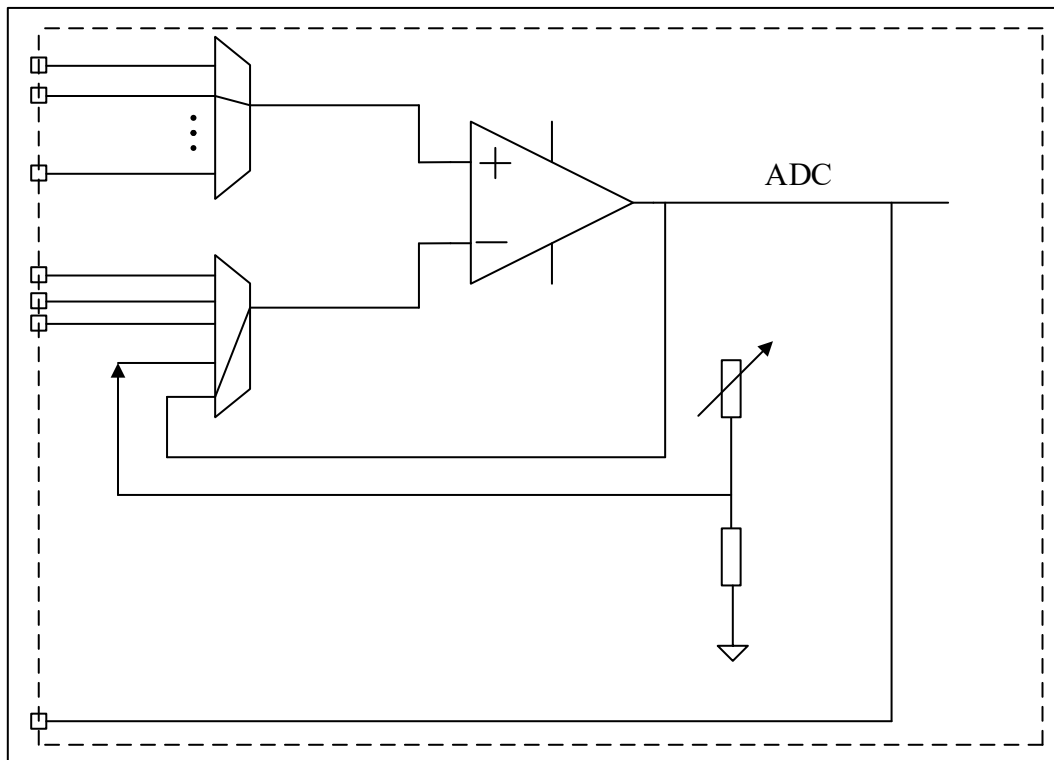
### 22.2.2 Follower Mode

In follower mode, the output voltage is directly following the input voltage. The VMSEL terminal must be configured to connected to the OPAMP output port.

When  $OPAMP\_CS.MOD = 2'b11$ , the OPAMP operates in internal follower mode. In this mode,  $OPAMAP\_CS.VPSSEL$  or  $OPAMAP\_CS.VPSEL$  selects non-inverted input,  $OPAMAP\_CS.VMSSEL$  or  $OPAMAP\_CS.VMSEL$  is connected to the output port from inside the chip.

Unoccupied VM pins can be used as other GPIOs.

Figure 22-3 OPAMP Follower Mode



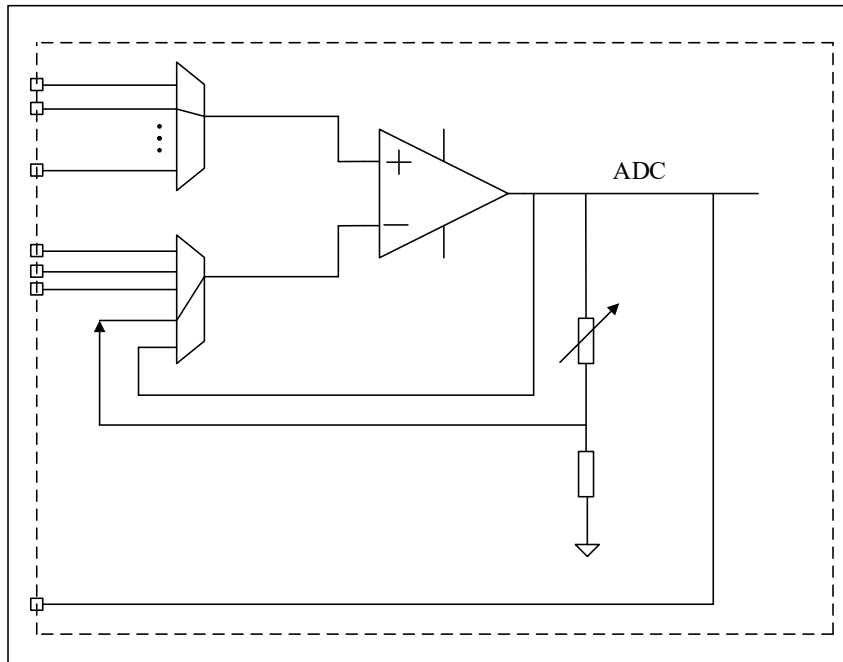
### 22.2.3 Programmable Gain Amplification (PGA) Mode

In the programming gain amplifier (PGA) mode, OPAMP amplifies the input voltage through the embedded resistance feedback network

When  $OPAMP\_CS.MOD = 2'b10$ , the OPAMP operates in PGA mode, it supports 2/4/8/16/32 amplification factors,  $OPAMP\_CS.VMSSEL$  or  $OPAMP\_CS.VMSEL$  pins must be set to float.  $OPAMP\_CS.VPSSEL$  or  $OPAMP\_CS.VPSEL$  selects non-inverted input. The non-inverted input can be connected to an external pin, which can be a resistive network. Set  $OPAMP\_CS.PGAGAN$  to gain selection. The output of an OPAMP can be connect to a resistive network.

OPAMP's VM input pin can be used as a normal GPIOs.

Figure 22-4 OPAMP Programmable Gain Mode



### 22.2.4 Independent Write Protection

The write protection of OPAMP can be set independently by configuring the OPAMP\_LOCK register. When the write protection is set, the software will not be able to write to the corresponding OPAMP register, and the write protection function can be canceled only after the chip is reset.

### 22.2.5 TIMER Controls The Switching Mode

In some applications, input switching of OPAMP can be done through TIM1\_CC6. TIM1\_CC6 controls the input switching of the OPAMP.

When TIM1\_CC6 is high, the OPAMP selects the port configured by VPSEL/VMSEL as the input; otherwise, it uses VPSEL/VMSEL as the input. OPAMP\_CS.TCMEN is set to 1 to enable the automatic switching input function. The process of configuring automatic switching is as follows:

- Enable automatic switching function OPAMP\_CS.TCMEN
- Configure two conversion MUX configuration (VPSEL, VMSEL, VPSEL, VMSEL)
- Start OPAMP and TIM

## 22.3 OPAMP Registers

### 22.3.1 OPAMP Register Overview

Table 22-1 OPAMP Register Overview

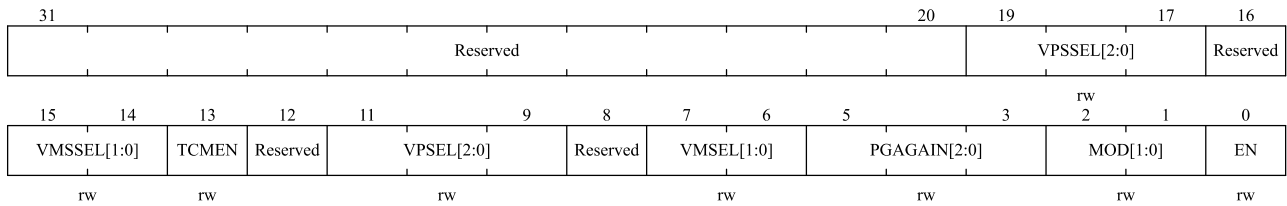
| Offset | Register | 31 | 30 | 29 | 28 | 27 | 26 | 25 | 24 | 23 | 22 | 21 | 20 | 19 | 18 | 17 | 16 | 15 | 14 | 13 | 12 | 11 | 10 | 9 | 8 | 7 | 6 | 5 | 4 | 3 | 2 | 1 | 0 |
|--------|----------|----|----|----|----|----|----|----|----|----|----|----|----|----|----|----|----|----|----|----|----|----|----|---|---|---|---|---|---|---|---|---|---|
|        |          |    |    |    |    |    |    |    |    |    |    |    |    |    |    |    |    |    |    |    |    |    |    |   |   |   |   |   |   |   |   |   |   |

|      |             |          |             |   |   |            |   |   |       |            |   |   |            |   |   |              |   |   |          |   |         |
|------|-------------|----------|-------------|---|---|------------|---|---|-------|------------|---|---|------------|---|---|--------------|---|---|----------|---|---------|
| 000h | OPAMP_CS    | Reserved | VPSSEL[3:0] |   |   | VMSEL[2:0] |   |   | TCMEN | VPSEL[3:0] |   |   | VMSEL[2:0] |   |   | PGAGAIN[2:0] |   |   | MOD[1:0] |   | EN      |
|      | Reset Value |          | 0           | 0 | 0 | 0          | 0 | 0 |       | 0          | 0 | 0 | 0          | 0 | 0 | 0            | 0 | 0 | 0        | 0 |         |
| 010h | OPA_LOCK    | Reserved |             |   |   |            |   |   |       |            |   |   |            |   |   |              |   |   |          |   | OPAMPLK |
|      | Reset Value | 0        |             |   |   |            |   |   |       |            |   |   |            |   |   |              |   |   |          |   |         |

### 22.3.2 Opamp Control Status Register (OPAMP\_CS)

Address offset: 0x00

Reset value: 0x0000 0000



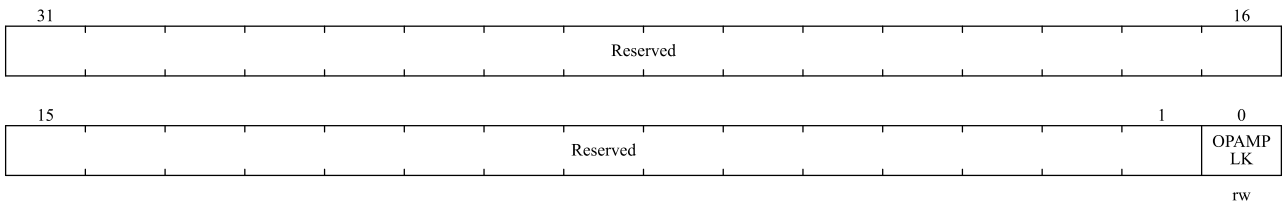
| Bit Field        | Name        | Description  |                  |       |     |     |     |     |     |     |     |     |     |     |     |     |     |      |
|------------------|-------------|--|------------------|-------|-----|-----|-----|-----|-----|-----|-----|-----|-----|-----|-----|-----|-----|------|
| 31:20            | Reserve     | Reserved, the reset value must be maintained   |                  |       |     |     |     |     |     |     |     |     |     |     |     |     |     |      |
| 19:17            | VPSSEL[2:0] | OPAMP Non inverted input secondary selection.<br>Same definition as VPSEL  |                  |       |     |     |     |     |     |     |     |     |     |     |     |     |     |      |
| 16               | Reserve     | Reserved, the reset value must be maintained   |                  |       |     |     |     |     |     |     |     |     |     |     |     |     |     |      |
| 15:14            | VMSEL[1:0]  | OPAMP Inverted input secondary selection<br>Same definition as VMSEL   |                  |       |     |     |     |     |     |     |     |     |     |     |     |     |     |      |
| 13               | TCMEN       | Timer control automatic switching mode enable<br>This bit is set or cleared by software and is used to control the automatic switching of primary and secondary inputs (VPSEL,VMSEL and VPSSEL,VMSEL).<br>TIM1_CC6 automatically switches to OPAMP.<br>0: Turn off automatic switching<br>1: Turn on automatic switching   |                  |       |     |     |     |     |     |     |     |     |     |     |     |     |     |      |
| 12               | Reserve     | Reserved, the reset value must be maintained   |                  |       |     |     |     |     |     |     |     |     |     |     |     |     |     |      |
| 11:9             | VPSEL[2:0]  | OPAMP Non Inverted input selection <table border="1" style="width: 100%; border-collapse: collapse;"> <thead> <tr> <th>Enumerated value</th> <th>OPAMP</th> </tr> </thead> <tbody> <tr> <td>000</td> <td>PF0</td> </tr> <tr> <td>001</td> <td>PA0</td> </tr> <tr> <td>010</td> <td>PA1</td> </tr> <tr> <td>011</td> <td>PA4</td> </tr> <tr> <td>100</td> <td>PA7</td> </tr> <tr> <td>101</td> <td>PB0</td> </tr> <tr> <td>110</td> <td>PB14</td> </tr> </tbody> </table> | Enumerated value | OPAMP | 000 | PF0 | 001 | PA0 | 010 | PA1 | 011 | PA4 | 100 | PA7 | 101 | PB0 | 110 | PB14 |
| Enumerated value | OPAMP       |  |                  |       |     |     |     |     |     |     |     |     |     |     |     |     |     |      |
| 000              | PF0         |  |                  |       |     |     |     |     |     |     |     |     |     |     |     |     |     |      |
| 001              | PA0         |  |                  |       |     |     |     |     |     |     |     |     |     |     |     |     |     |      |
| 010              | PA1         |  |                  |       |     |     |     |     |     |     |     |     |     |     |     |     |     |      |
| 011              | PA4         |  |                  |       |     |     |     |     |     |     |     |     |     |     |     |     |     |      |
| 100              | PA7         |  |                  |       |     |     |     |     |     |     |     |     |     |     |     |     |     |      |
| 101              | PB0         |  |                  |       |     |     |     |     |     |     |     |     |     |     |     |     |     |      |
| 110              | PB14        |  |                  |       |     |     |     |     |     |     |     |     |     |     |     |     |     |      |
| 8                | Reserve     | Reserved, the reset value must be maintained   |                  |       |     |     |     |     |     |     |     |     |     |     |     |     |     |      |

| Bit Field        | Name        | Description   |                  |       |    |     |    |     |    |     |    |     |
|------------------|-------------|---|------------------|-------|----|-----|----|-----|----|-----|----|-----|
| 7:6              | VMSEL[1:0]  | OPAMP Inverted input selection <table border="1" style="margin-left: 20px;"> <thead> <tr> <th>Enumerated value</th> <th>OPAMP</th> </tr> </thead> <tbody> <tr> <td>00</td> <td>PA2</td> </tr> <tr> <td>01</td> <td>PA5</td> </tr> <tr> <td>10</td> <td>PB1</td> </tr> <tr> <td>11</td> <td>PB2</td> </tr> </tbody> </table> | Enumerated value | OPAMP | 00 | PA2 | 01 | PA5 | 10 | PB1 | 11 | PB2 |
| Enumerated value | OPAMP       |   |                  |       |    |     |    |     |    |     |    |     |
| 00               | PA2         |   |                  |       |    |     |    |     |    |     |    |     |
| 01               | PA5         |   |                  |       |    |     |    |     |    |     |    |     |
| 10               | PB1         |   |                  |       |    |     |    |     |    |     |    |     |
| 11               | PB2         |   |                  |       |    |     |    |     |    |     |    |     |
| 5:3              | PGAGAN[2:0] | OPAMP Programmable amplifier gain value<br>000: Internal PGA gain 2<br>001: Internal PGA gain 4<br>010: Internal PGA gain 8<br>011: Internal PGA gain 16<br>100: Internal PGA gain 32<br>Others: internal PGA gain 2  |                  |       |    |     |    |     |    |     |    |     |
| 2:1              | MOD[1:0]    | OPAMP PGA mode<br>0x: External gain mode<br>10: Internal PGA enable<br>11: Internal follower mode   |                  |       |    |     |    |     |    |     |    |     |
| 0                | EN          | OPAMP Enable<br>0: Disable<br>1: Enable   |                  |       |    |     |    |     |    |     |    |     |

### 22.3.3 Opamp Lock Register (OPAMP\_LOCK)

Address offset: 0x4

Reset value: 0x0000 0000



| Bit Field | Name    | Description  |
|-----------|---------|--|
| 31:1      | Reserve | Reserved, the reset value must be maintained   |
| 0         | OPAMPLK | OPAMP Lock bit<br>After the reset, this bit can be written only once<br>0: The OPAMP register is readable and writable<br>1: The OPAMP register is read-only |

## 23 Beeper

### 23.1 Introduction

The Beeper module supports complementary outputs and can generate periodic signals to drive external passive Beepers. It is used to generate a prompt tone or an alarm sound.

### 23.2 Function Description

The Beeper, as an independent module, is connected to the APB1 bus with a maximum operating frequency of 48MHz. The timbre can be divided into 21 grades, and different timbres can be adjusted by configuring the relevant registers when using. One of the two outputs is usually turned off. If the reverse output is enabled, the two outputs are turned on at the same time and output in a complementary manner. It supports operating in LPRUN mode. At this time, the output frequency of the Beeper depends on PCLK1, and is the 4 frequency division value of PCLK1.

### 23.3 Beeper Registers

These peripheral registers must be operated in word (32-bit) mode.

#### 23.3.1 Beeper Register Overview

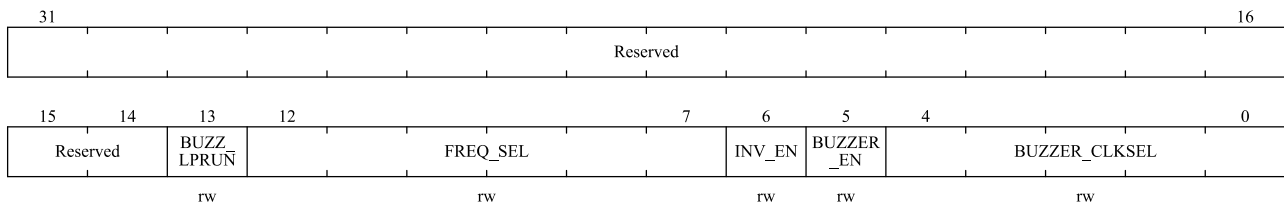
Table 23-1 Beeper Register Overview

| Offset | Register    | 31       | 30 | 29 | 28 | 27 | 26 | 25 | 24 | 23 | 22 | 21 | 20 | 19 | 18 | 17 | 16 | 15 | 14 | 13         | 12            | 11 | 10 | 9 | 8 | 7      | 6         | 5                  | 4 | 3 | 2 | 1 | 0 |   |   |   |   |   |   |   |   |   |   |   |   |   |   |   |   |
|--------|-------------|----------|----|----|----|----|----|----|----|----|----|----|----|----|----|----|----|----|----|------------|---------------|----|----|---|---|--------|-----------|--------------------|---|---|---|---|---|---|---|---|---|---|---|---|---|---|---|---|---|---|---|---|---|
| 000h   | BEEPER_CTRL | Reserved |    |    |    |    |    |    |    |    |    |    |    |    |    |    |    |    |    | BUZZ_LPRUN | FREQ_SEL[5:0] |    |    |   |   | INV_EN | BUZZER_EN | BUZZER_CLKSEL[4:0] |   |   |   |   |   |   |   |   |   |   |   |   |   |   |   |   |   |   |   |   |   |
|        | Reset Value |          |    |    |    |    |    |    |    |    |    |    |    |    |    |    |    |    |    | 0          | 0             | 0  | 0  | 0 | 0 | 0      | 0         | 0                  | 0 | 0 | 0 | 0 | 0 | 0 | 0 | 0 | 0 | 0 | 0 | 0 | 0 | 0 | 0 | 0 | 0 | 0 | 0 | 0 | 0 |

#### 23.3.2 Beeper Control Register (BEEPER\_CTRL)

Address offset: 0x00

Reset value: 0x0000 0000



| Bit Field | Name       | Description  |
|-----------|------------|--|
| 31:14     | Reserved   | Reserved, the reset value must be maintained.  |
| 13        | BUZZ_LPRUN | Beeper low power mode selection, if BUZZ_LPRUN and BUZZER_EN are turned on at the same time, Beeper will enter LPRUN mode. At this time, the |

| Bit Field | Name               | Description   |
|-----------|--------------------|---|
|           |                    | <p>Beeper output frequency is the 4-divided value of PCLK1.</p> <p>0: Normal mode.</p> <p>1: LPRUN mode.</p>  |
| 12:7      | FREQ_SEL[5:0]      | <p>MCU APB frequency selection signal. The corresponding frequency signal is selected according to the APB frequency, so that the output frequency will not be distorted. The value ranges from 1 to 48M, and 0 is also mapped to 48M.</p> <p>000000: 48M</p> <p>000001: 1M</p> <p>000010: 2M</p> <p>000011: 3M</p> <p>...</p> <p>110000: 48M</p>   |
| 6         | INV_EN             | <p>Beeper complementary output enable</p> <p>0: There is only one output, and the other output is closed.</p> <p>1: Both outputs are turned on, and the outputs are complementary</p>   |
| 5         | BUZZER_EN          | <p>Beeper enable</p> <p>0: Beeper disabled</p> <p>1: Beeper enabled</p>   |
| 4:0       | BUZZER_CLKSEL[4:0] | <p>Beeper output frequency selection:</p> <p>00001: L1 (Bass 1)</p> <p>00010: L2 (Bass 2)</p> <p>00011: L3 (Bass 3)</p> <p>00100: L4 (Bass 4)</p> <p>00101: L5 (Bass 5)</p> <p>00110: L6 (Bass 6)</p> <p>00111: L7 (Bass 7)</p><br><p>01000: M1 (Alto 1)</p> <p>01001: M2 (Alto 2)</p> <p>01010: M3 (Alto 3)</p> <p>01011: M4 (Alto 4)</p> <p>01100: M5 (Alto 5)</p> <p>01101: M6 (Alto 6)</p> <p>01110: M7 (Alto 7)</p><br><p>01111: H1 (Treble 1)</p> <p>10000: H2 (Treble 2)</p> <p>10001: H3 (Treble 3)</p> <p>10010: H4 (Treble 4)</p> <p>10011: H5 (Treble 5)</p> <p>10100: H6 (Treble 6)</p> |

| Bit Field | Name | Description                              |
|-----------|------|--|
|           |      | 10101: H7 (Treble 7)<br><br>default: ... |



## 24 Arithmetic Units (HDIV and SQRT)

### 24.1 Introductions of HDIV and SQRT

The divider (HDIV) and square root calculator (SQRT) are mainly used in some scenarios with high requirements for computing energy efficiency, and are used to partially supplement the computational shortcomings of the microcontroller. The divider and square root calculator can perform division operations or square root calculations on unsigned 32-bit integers.

### 24.2 HDIV and SQRT Function Description

- Only supports word operation
- 8 clock cycles to complete an unsigned integer division operation
- 32-bit dividend, 32-bit divisor, output 32-bit quotient and 32-bit remainder
- Including the divisor is zero warning flag and the division operation end flag
- 32-bit unsigned square integer, 16-bit squared root output
- 8 clock cycles to complete an unsigned integer square operation
- Checking whether the calculation is complete or not can be determined by setting the interrupt enable or querying the relevant register bit

### 24.3 HDIV Registers

#### 24.3.1 HDIV Register Overview

Table 24-1 HDIV Register Overview

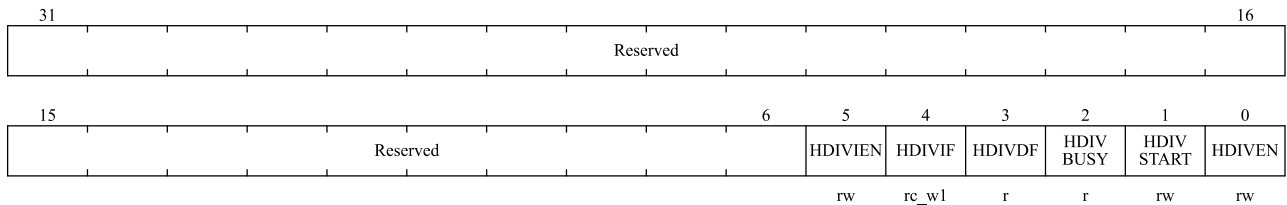
| Offset | Register       | 31        | 30 | 29 | 28 | 27 | 26 | 25 | 24 | 23 | 22 | 21 | 20 | 19 | 18 | 17 | 16 | 15 | 14 | 13 | 12 | 11 | 10 | 9 | 8 | 7      | 6     | 5      | 4        | 3         | 2      | 1 | 0 |
|--------|----------------|-----------|----|----|----|----|----|----|----|----|----|----|----|----|----|----|----|----|----|----|----|----|----|---|---|--------|-------|--------|----------|-----------|--------|---|---|
| 000h   | HDIV_CTRLSTS   | Reserved  |    |    |    |    |    |    |    |    |    |    |    |    |    |    |    |    |    |    |    |    |    |   |   | HDIVEN | HDIVF | HDIVDF | HDIVBUSY | HDIVSTART | HDIVEN |   |   |
|        | Reset Value    |           |    |    |    |    |    |    |    |    |    |    |    |    |    |    |    |    |    |    |    |    |    |   |   | 0      | 0     | 0      | 0        | 0         |        |   |   |
| 004h   | HDIV_DIVIDEND  | DIVIDEND  |    |    |    |    |    |    |    |    |    |    |    |    |    |    |    |    |    |    |    |    |    |   |   |        |       |        |          |           |        |   |   |
|        | Reset Value    | 0         | 0  | 0  | 0  | 0  | 0  | 0  | 0  | 0  | 0  | 0  | 0  | 0  | 0  | 0  | 0  | 0  | 0  | 0  | 0  | 0  | 0  | 0 | 0 | 0      | 0     | 0      | 0        | 0         | 0      | 0 |   |
| 008h   | HDIV_DIVISOR   | DIVISOR   |    |    |    |    |    |    |    |    |    |    |    |    |    |    |    |    |    |    |    |    |    |   |   |        |       |        |          |           |        |   |   |
|        | Reset Value    | 0         | 0  | 0  | 0  | 0  | 0  | 0  | 0  | 0  | 0  | 0  | 0  | 0  | 0  | 0  | 0  | 0  | 0  | 0  | 0  | 0  | 0  | 0 | 0 | 0      | 0     | 0      | 0        | 0         | 0      | 0 |   |
| 00Ch   | HDIV_QUOTIENT  | QUOTIENT  |    |    |    |    |    |    |    |    |    |    |    |    |    |    |    |    |    |    |    |    |    |   |   |        |       |        |          |           |        |   |   |
|        | Reset Value    | 0         | 0  | 0  | 0  | 0  | 0  | 0  | 0  | 0  | 0  | 0  | 0  | 0  | 0  | 0  | 0  | 0  | 0  | 0  | 0  | 0  | 0  | 0 | 0 | 0      | 0     | 0      | 0        | 0         | 0      | 0 |   |
| 010h   | HDIV_REMAINDER | REMAINDER |    |    |    |    |    |    |    |    |    |    |    |    |    |    |    |    |    |    |    |    |    |   |   |        |       |        |          |           |        |   |   |
|        | Reset Value    | 0         | 0  | 0  | 0  | 0  | 0  | 0  | 0  | 0  | 0  | 0  | 0  | 0  | 0  | 0  | 0  | 0  | 0  | 0  | 0  | 0  | 0  | 0 | 0 | 0      | 0     | 0      | 0        | 0         | 0      | 0 |   |



### 24.3.2 HDIV Control Status Register (HDIV\_CTRLSTS)

Offset address: 0x00

Reset value: 0x0000 0000

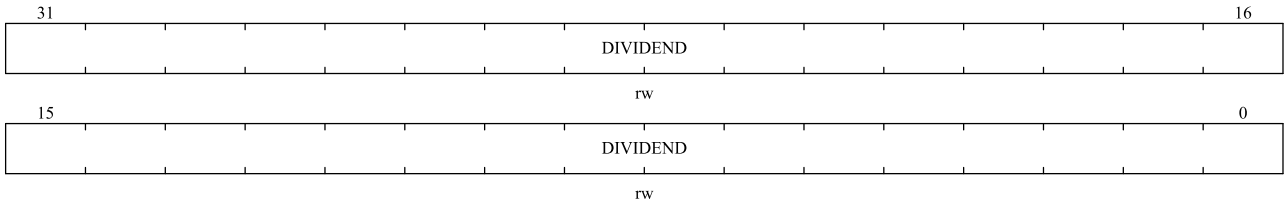


| Bit Field | Name      | Description   |
|-----------|-----------|---|
| 31:6      | Reserved  | Reserved, the reset value must be maintained  |
| 5         | HDIVIEN   | Divider interrupt enable<br>0: Disable interrupt<br>1: Enable interrupt   |
| 4         | HDIVIF    | The divider interrupt flag bit, which generates an interrupt signal when the interrupt enable is turned on<br>0: No interrupt is generated<br>1: The division calculation is completed and an interrupt is generated<br>Software writes '1' to clear this status bit. |
| 3         | HDIVDF    | Completion of calculation flag.<br>0: The division calculation has not ended or has not started<br>1: The division calculation ends. Readable quotient and remainder  |
| 2         | HDIVBUSY  | Divider busy flag<br>0: Divider idle<br>1: Divider is operating   |
| 1         | HDIVSTART | Divider start bit<br>0: Wait for the division operation to start<br>1: Start the division calculation<br>Writing this register bit triggers the start of the division operation   |
| 0         | HDIVEN    | Divider module enable<br>0: Close the divider module<br>1: Enable divider module  |

### 24.3.3 HDIV Dividend Register (HDIV\_DIVIDEND)

Offset address: 0x04

Reset value: 0x0000 0000

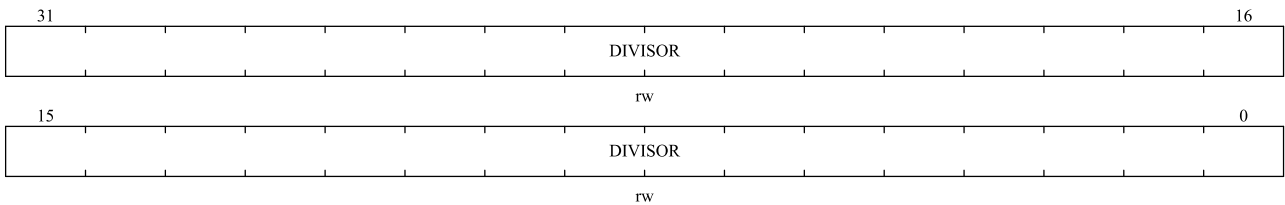


| Bit Field | Name     | Description                         |
|-----------|----------|-------------------------------------|
| 31:0      | DIVIDEND | 32-bit unsigned integer as dividend |

### 24.3.4 HDIV Divisor Register (HDIV\_DIVISOR)

Offset address: 0x08

Reset value: 0x0000 0000

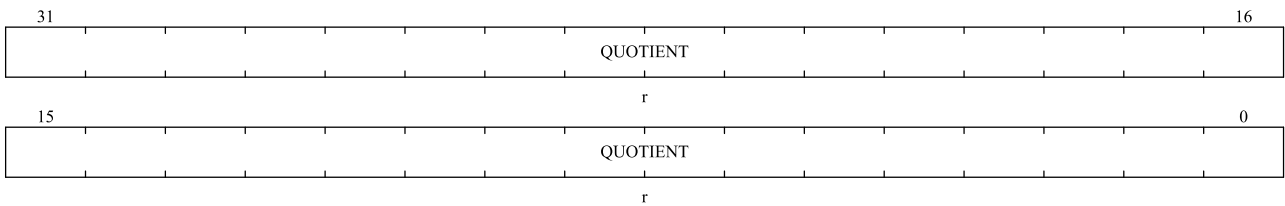


| Bit Field | Name    | Description                        |
|-----------|---------|------------------------------------|
| 31:0      | DIVISOR | 32-bit unsigned integer as divisor |

### 24.3.5 HDIV Quotient Register (HDIV\_QUOTIENT)

Offset address: 0x0C

Reset value: 0x0000 0000

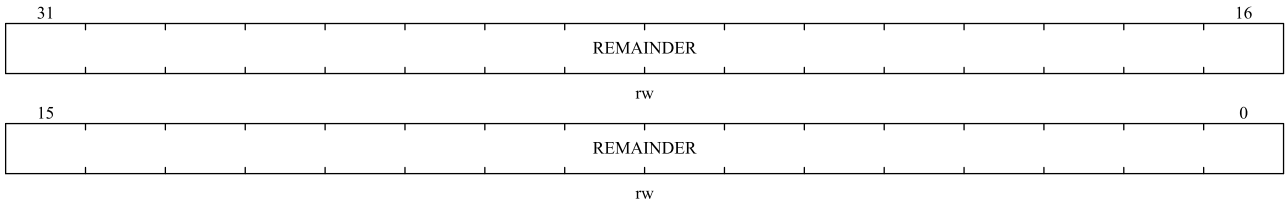


| Bit Field | Name     | Description                        |
|-----------|----------|------------------------------------|
| 31:0      | QUOTIENT | Quotient calculated by the divider |

### 24.3.6 HDIV Remainder Register (HDIV\_REMAINDER)

Offset address: 0x10

Reset value: 0x0000 0000

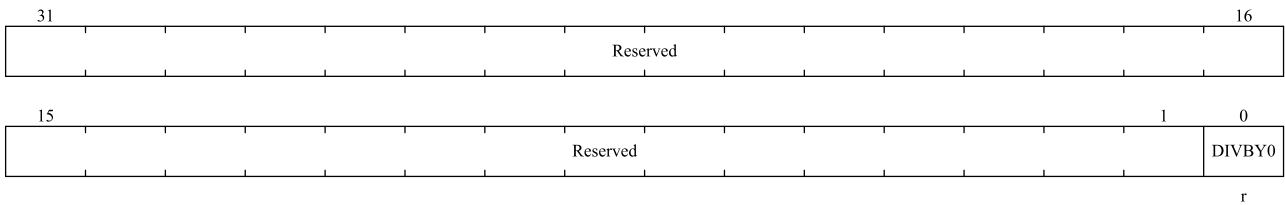


| Bit Field | Name      | Description                         |
|-----------|-----------|-------------------------------------|
| 31:0      | REMAINDER | Remainder calculated by the divider |

### 24.3.7 HDIV Divide by Zero Register (HDIV\_DIVBY0)

Offset address: 0x14

Reset value: 0x0000 0000



| Bit Field | Name     | Description   |
|-----------|----------|---|
| 31:1      | Reserved | Reserved,the reset value must be maintained                 |
| 0         | DIVBY0   | Divisor is 0 flag<br>0: Divisor is not 0<br>1: Divisor is 0 |

## 24.4 Sqrt Registers

### 24.4.1 Sqrt Register Overview

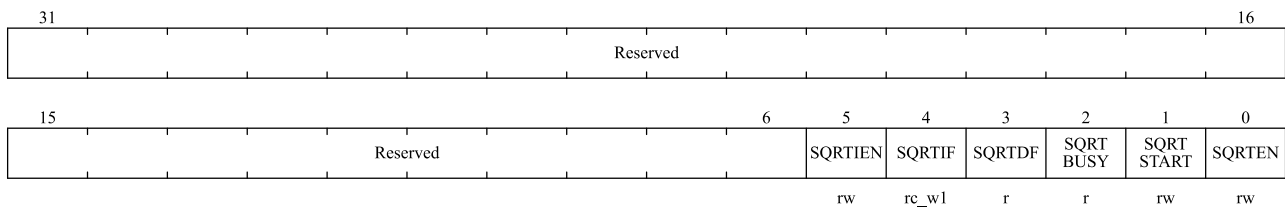
Table 24-2 Sqrt Register Overview

| Offset | Register      | 31       | 30 | 29 | 28 | 27 | 26 | 25 | 24 | 23 | 22 | 21 | 20 | 19 | 18 | 17 | 16 | 15   | 14 | 13 | 12 | 11 | 10 | 9 | 8 | 7       | 6      | 5      | 4        | 3         | 2      | 1 | 0 |   |   |   |   |   |   |   |   |   |   |   |   |   |
|--------|---------------|----------|----|----|----|----|----|----|----|----|----|----|----|----|----|----|----|------|----|----|----|----|----|---|---|---------|--------|--------|----------|-----------|--------|---|---|---|---|---|---|---|---|---|---|---|---|---|---|---|
| 000h   | SQRT_CTRLSTS  | Reserved |    |    |    |    |    |    |    |    |    |    |    |    |    |    |    |      |    |    |    |    |    |   |   | SQRTIEN | SQRTIF | SQRTDF | SQRTBUSY | SQRTSTART | SQRTEN |   |   |   |   |   |   |   |   |   |   |   |   |   |   |   |
|        | Reset Value   |          |    |    |    |    |    |    |    |    |    |    |    |    |    |    |    |      |    |    |    |    |    |   |   | 0       | 0      | 0      | 0        | 0         | 0      |   |   |   |   |   |   |   |   |   |   |   |   |   |   |   |
| 004h   | SQRT_RADICAND | RADICAND |    |    |    |    |    |    |    |    |    |    |    |    |    |    |    |      |    |    |    |    |    |   |   |         |        |        |          |           |        |   |   |   |   |   |   |   |   |   |   |   |   |   |   |   |
|        | Reset Value   | 0        | 0  | 0  | 0  | 0  | 0  | 0  | 0  | 0  | 0  | 0  | 0  | 0  | 0  | 0  | 0  | 0    | 0  | 0  | 0  | 0  | 0  | 0 | 0 | 0       | 0      | 0      | 0        | 0         | 0      | 0 |   |   |   |   |   |   |   |   |   |   |   |   |   |   |
| 008h   | SQRT_ROOT     | Reserved |    |    |    |    |    |    |    |    |    |    |    |    |    |    |    | ROOT |    |    |    |    |    |   |   |         |        |        |          |           |        |   |   |   |   |   |   |   |   |   |   |   |   |   |   |   |
|        | Reset Value   |          |    |    |    |    |    |    |    |    |    |    |    |    |    |    |    | 0    | 0  | 0  | 0  | 0  | 0  | 0 | 0 | 0       | 0      | 0      | 0        | 0         | 0      | 0 | 0 | 0 | 0 | 0 | 0 | 0 | 0 | 0 | 0 | 0 | 0 | 0 | 0 | 0 |

### 24.4.2 Sqrt Control Status Register (SQRT\_CTRLSTS)

Offset address: 0x00

Reset value: 0x0000 0000

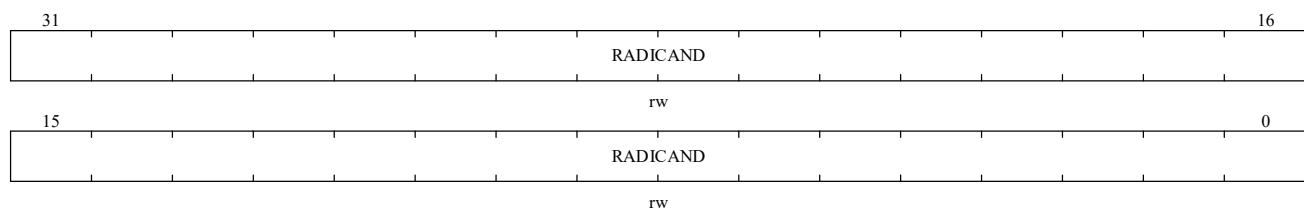


| Bit Field | Name      | Description   |
|-----------|-----------|---|
| 31:6      | Reserved  | Reserved,the reset value must be maintained   |
| 5         | SQRTIEN   | The square root calculator interrupt enable<br>0: Disable interrupt<br>1: Enable interrupt  |
| 4         | SQRTIF    | The square root calculator interrupt flag bit, which generates an interrupt signal when the interrupt enable is turned on<br>0: No interrupt is generated<br>1: The square root calculation is completed and an interrupt is generated<br>Software writes '1' to clear the status bit |
| 3         | SQRTDF    | The square root calculator computes the complete flag bit.<br>0: The calculation has not ended or not started<br>1: End of calculation  |
| 2         | SQRTBUSY  | The square root calculator busy flag bit<br>0: The opening calculator is idle<br>1: The square root calculator is operating   |
| 1         | SQRTSTART | The square root calculation start bit<br>0: Waiting for the start of square root calculation<br>1: Configure 1 to start the square root calculation<br>Write this register bit to trigger the start of the square root operation  |
| 0         | SQRTEN    | The square root calculator module enable:<br>0: Turn off the square root calculator module<br>1: Enable the square root calculator module   |

### 24.4.3 SQRT Radicand Register (SQRT\_RADICAND)

Offset address: 0x04

Reset value: 0x0000 0000

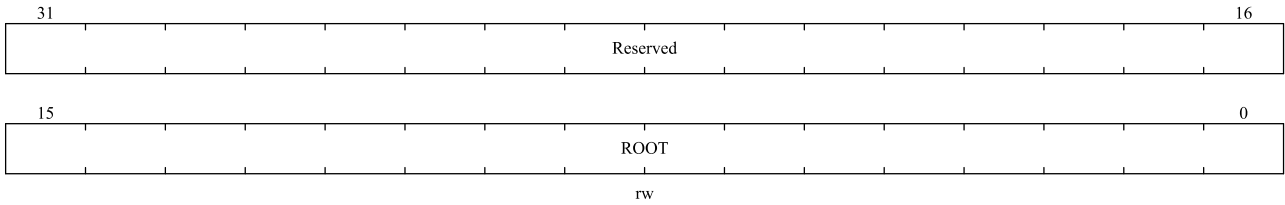


| Bit Field | Name     | Description                         |
|-----------|----------|-------------------------------------|
| 31:0      | RADICAND | 32-bit unsigned integer as radicand |

#### 24.4.4 SQRT Square Root Register (SQRT\_ROOT)

Offset address: 0x08

Reset value: 0x0000 0000



| Bit Field | Name     | Description                                 |
|-----------|----------|---|
| 31:16     | Reserved | Reserved,the reset value must be maintained |
| 15:0      | ROOT     | 16-bit square root output                   |

## 25 Debug Support (DBG)

### 25.1 Overview

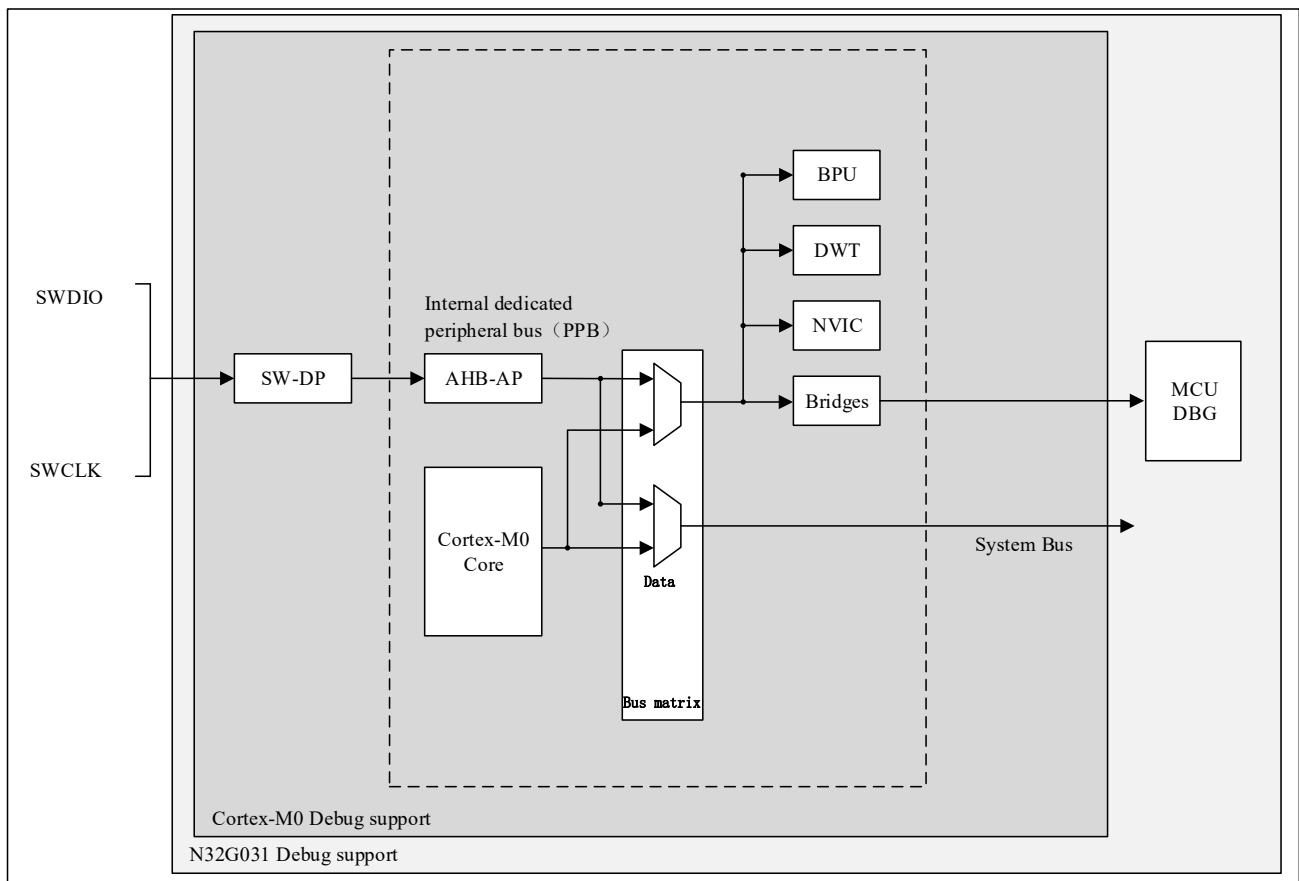
The N32G031 uses Cortex®-M0 core, which integrates hardware debugging module. It supports instruction breakpoint (stops when fetching instructions) and data breakpoint (stops when accessing data). When the core is stopped, the user can view the internal state of the core and the external state of the system. After the user's query operation is completed, the core and peripherals can be restored, and the corresponding program can continue to be executed.

The hardware debugging module of the N32G031 core can be used when it is connected to the debugger (when it is not disabled).

N32G031 supports the following debugging interfaces:

- Serial interface

**Figure 25-1 N32G031 Level And Cortex®-M0 Level Debugging Block Diagram**



The ARM Cortex®-M0 core hardware debugging module can provide the following debugging functions:

- SW-DP: serial debugging port
- AHP-AP: AHB access port

- BPU: breakpoint generation
- DWT: data trigger

Reference:

- Cortex<sup>®</sup>-M0 Technical Reference Manual (TRM)
- ARM debug interface V5 structure specification
- ARM CoreSight development tool set (r1p0 version) technical reference manual

## 25.2 SWD Function

The debugging tool can call the debugging function through the above-mentioned SWD debugging interface.

### 25.2.1 Pin Assignment

SWD (serial debug) interface consists of two pins: SWCLK (clock pin) and SWDIO (data input and output pin).

The pin assignment of SWD debug interface is shown in the following table:

**Table 25-1 Debug Port Pin**

| Debug Port | Pin Assignment |
|------------|----------------|
| SWDIO      | PA13           |
| SWCLK      | PA14           |



## 26 Unique Device Serial Number (UID)

### 26.1 Introduction

The MCU series products have two embedded unique device serial numbers with different lengths, namely 96-bit UID (Unique device ID) and 128-bit UCID (Unique Customer ID). These two device serial numbers are stored in the system configuration block of the Flash memory. The information they contain is written at the factory and ensures that each MCU is unique in any situation. They can be read by user applications or external devices through CPU or SWD interface and cannot be modified.

UID is 96 bits, which is usually used as serial number or password. When writing to Flash memory, this unique identifier is combined with software encryption and decryption algorithm to further improve the security of code in Flash memory, and it can also be used to activate Secure Bootloader with security function.

UCID is 128 bits and complies with the definition of the Nsing Technologies chip serial number. It contains information about chip production and version.

In addition to the above two device serial numbers, there is also a 32-bit DBGMCU\_ID, which contains the chip version number, chip model, and Flash/SRAM capacity information.

### 26.2 UID Register

Start address: 0x1FFF\_F4FC, 96 bits in length.

### 26.3 UCID Register

Start address: 0x1FFF\_F4D0, 128 bits in length.

### 26.4 DBGMCU\_ID Register

Start address: 0x1FFF\_F508, 32 bits in length. Different bytes are arranged with the low byte first and the high byte last; within the same byte, the high bit comes first and the low bit comes last.

**Table 26-1 DBGMCU\_ID Bit Description**

| Description         | Size | Remark   |
|---------------------|------|--|
| Chip version number | 4bit | The lower 4 bits of the chip version number.   |
|                     | 4bit | The upper 4 bits of the chip version number.   |
| Chip model          | 4bit | The upper 4 bits of the device model number.<br>The device model consists of 12 high, middle and low bits, representing the model of the chip. |
|                     | 4bit | The middle 4 bits of the device model number.  |
|                     | 4bit | The lower 4 bits of the device model number.   |
| Flash capacity      | 4bit | Flash capacity indicator.<br>16KB as unit, Flash size = N * 16KB   |

|               |      |  |
|---------------|------|--|
| SRAM capacity | 4bit | SRAM capacity indicator.<br>4KB as unit, SRAM size = N * 4KB |
| Reserved      | 4bit | Keep it all 1.   |

## 27 Version History

| Version | Date      | Changes   |
|---------|-----------|---|
| V2.0    | 2022.4.28 | Initial version   |
| V2.1    | 2022.9.13 | <ol style="list-style-type: none"> <li>1. Section 7.4.11, modify DMA channel sel 36 to 35</li> <li>2. Section 9.4.20 and section 10.4.18, modify DMA burst valid address range of TIM, for register after TIMx_DCTRL, DMA burst is invalid. Section 3.1.1.1, 3.4.7, 3.2.3, 3.1.1, delete 1.0v output in stop mode.</li> <li>3. Section 19.2, modify LPUART max rate to 1Mbps.</li> <li>4. Section 21.4.12, when AD1S is set to 1, SUBF[14:0] cannot be all 0.</li> </ol>  |
| V2.2.0  | 2023.8.1  | <ol style="list-style-type: none"> <li>1. Section 26.2 and 26.3, modify the starting address of UID and UCID.</li> <li>2. Section 6.1.1, modify the value from 9000 to 6000, 1.5ms to 1ms.</li> <li>3. Section 5.2.2, delete "PA0 are multiplexed to OSC_IN".</li> <li>4. Section 20.4.2, modify clock generator diagram.</li> <li>5. Section 21.3.6, add notes when RTC enters initialization mode.</li> <li>6. Section 21.4.12, modify RTC_SCTRL. SUBF[14:0] register description.</li> <li>7. Section 7.4.6, add notes related to the configuration process.</li> <li>8. Section 21.3.7, add notes when calendar initialization and calendar reading.</li> <li>9. Section 13.4.1, modify Table 13-1 IWDG counting maximum and minimum reset time.</li> <li>10. Section 17.3.2.6, add notes for configuring the slave address in 7-bit address mode.</li> </ol> |
|         |           |   |

## 28 Disclaimer

This document is the exclusive property of NSING TECHNOLOGIES PTE. LTD.(Hereinafter referred to as NSING).

This document, and the product of NSING described herein (Hereinafter referred to as the Product) are owned by NSING under the laws and treaties of Republic of Singapore and other applicable jurisdictions worldwide. The intellectual properties of the product belong to Nations Technologies Inc. and Nations Technologies Inc. does not grant any third party any license under its patents, copyrights, trademarks, or other intellectual property rights. Names and brands of third party may be mentioned or referred thereto (if any) for identification purposes only. NSING reserves the right to make changes, corrections, enhancements, modifications, and improvements to this document at any time without notice. Please contact NSING and obtain the latest version of this document before placing orders.

Although NATIONS has attempted to provide accurate and reliable information, NATIONS assumes no responsibility for the accuracy and reliability of this document. It is the responsibility of the user of this document to properly design, program, and test the functionality and safety of any application made of this information and any resulting product. In no event shall NATIONS be liable for any direct, indirect, incidental, special, exemplary, or consequential damages arising in any way out of the use of this document or the Product.

NATIONS Products are neither intended nor warranted for usage in systems or equipment, any malfunction or failure of which may cause loss of human life, bodily injury or severe property damage. Such applications are deemed, 'Insecure Usage'. Insecure usage includes, but is not limited to: equipment for surgical implementation, atomic energy control instruments, airplane or spaceship instruments, all types of safety devices, and other applications intended to supporter sustain life. All Insecure Usage shall be made at user's risk. User shall indemnify NATIONS and hold NATIONS harmless from and against all claims, costs, damages, and other liabilities, arising from or related to any customer's Insecure Usage Any express or implied warranty with regard to this document or the Product, including, but not limited to. The warranties of merchantability, fitness for a particular purpose and non-infringement are disclaimed to the fullest extent permitted by law. Unless otherwise explicitly permitted by NATIONS, anyone may not use, duplicate, modify, transcribe or otherwise distribute this document for any purposes, in whole or in part.